

**RoboCylinder Separate & Built-in Controller
Types with Battery-less Absolute Encoder**

PowerCon Controller for RoboCylinder

RCP6/RCP6S Series PCON-CB/CFB

**ROBO
CYLINDER**

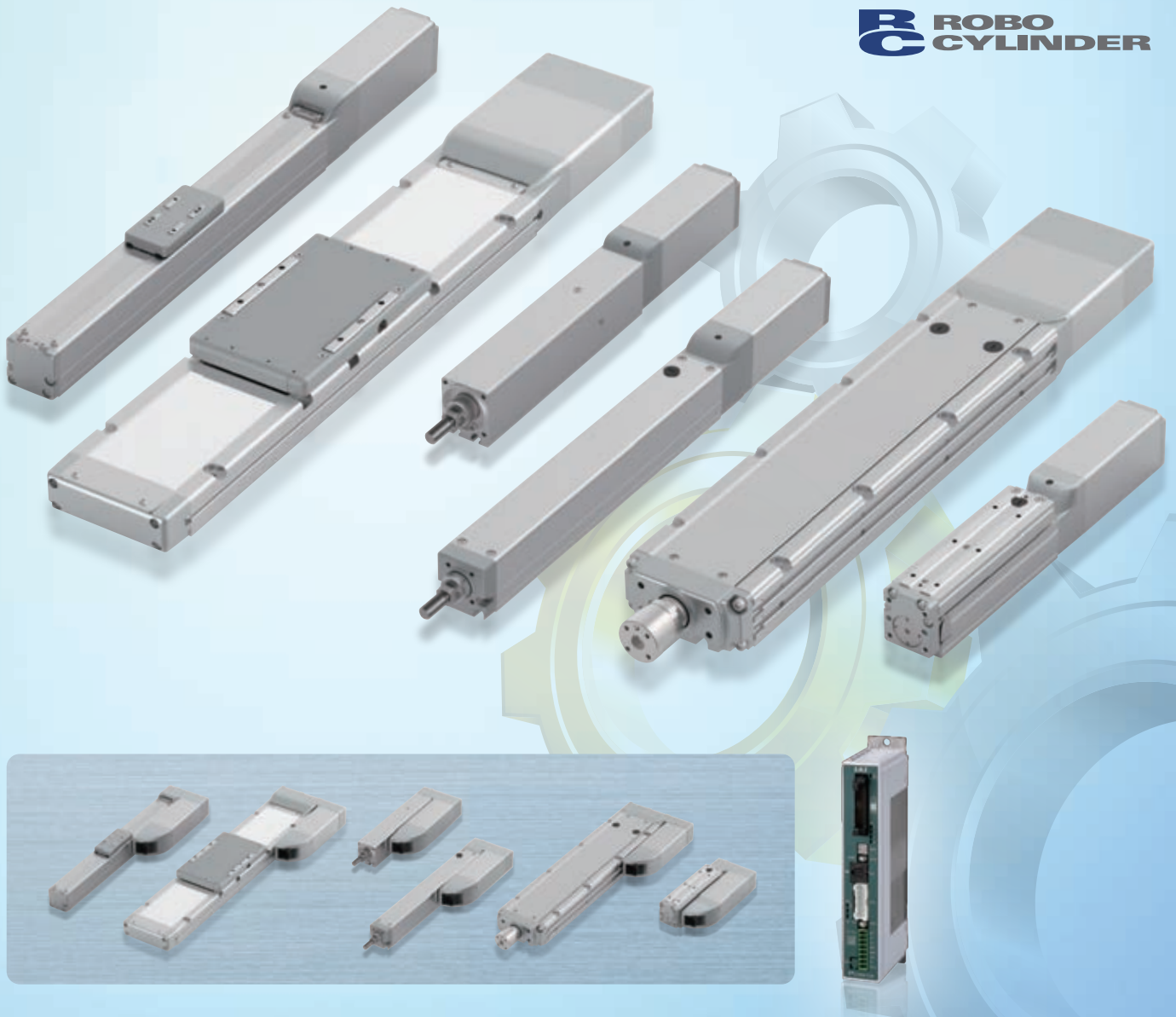

IAI's Next Generation RoboCylinder: RCP6

You Can Select the Product That Best Suits Your Needs from an Abundant Lineup of 92 Models.

1 Equipped with High-resolution Battery-less Absolute Encoder as Standard.

The advantages of an actuator with battery-less absolute encoder

No battery maintenance is required since there is no battery. Since home-return operation is not required at start up or after emergency stop or malfunction, this reduces your operation time, resulting in reduced production costs. Price is the same as the conventional incremental encoders.

The advantages of using an absolute encoder.

1. With an absolute encoder, home-return is not required.
2. No external home sensor is required since home-return is not necessary.
3. Removal of items being worked on is not necessary, even after an emergency stop.
4. The troublesome creation of home-return programs is not necessary even when stopping in the complex inside of a machine.

The advantages of battery-less

1. No battery maintenance required
2. No installation space for battery required

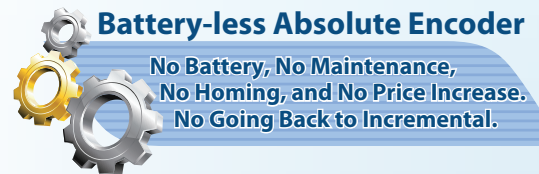

Built-in position memory system

2 Improved Positioning Repeatability

With the improvement of the accurate processing technology of rolled ball screws and the thread grooves of nuts, a significantly higher precision compared to the previous RoboCylinder's positioning repeatability ($\pm 20\mu\text{m}$) has been achieved.

Standard specification $\pm 10\mu\text{m}$

High-precision specification $\pm 5\mu\text{m}$

(Available only for RCP6-SA/WSA)

3 PowerCon Compatible

Compatible with PowerCon which is equipped with a high-output driver. The output of the stepper motor has increased by about 50% due to the use of PowerCon. This can reduce cycle time and help improve productivity.

4 The Built-in Controller Type Is Available for All Models.

Standard/separate controller type or built-in controller type can be selected for all models.

The advantages of a built-in controller type.

- ▶ Smaller control panel.
- ▶ Simple wiring.
- ▶ Less maintenance parts necessary because wires are being shared.

By using the gateway unit and the hub unit(s), it is possible to reduce the size of the control panel and a number of cables.

*Please refer to P.6 for more information regarding the gateway unit and the hub unit.

Control Panel for Standard Controller

Control Panel for the RCP6S Built-in Controller Actuator

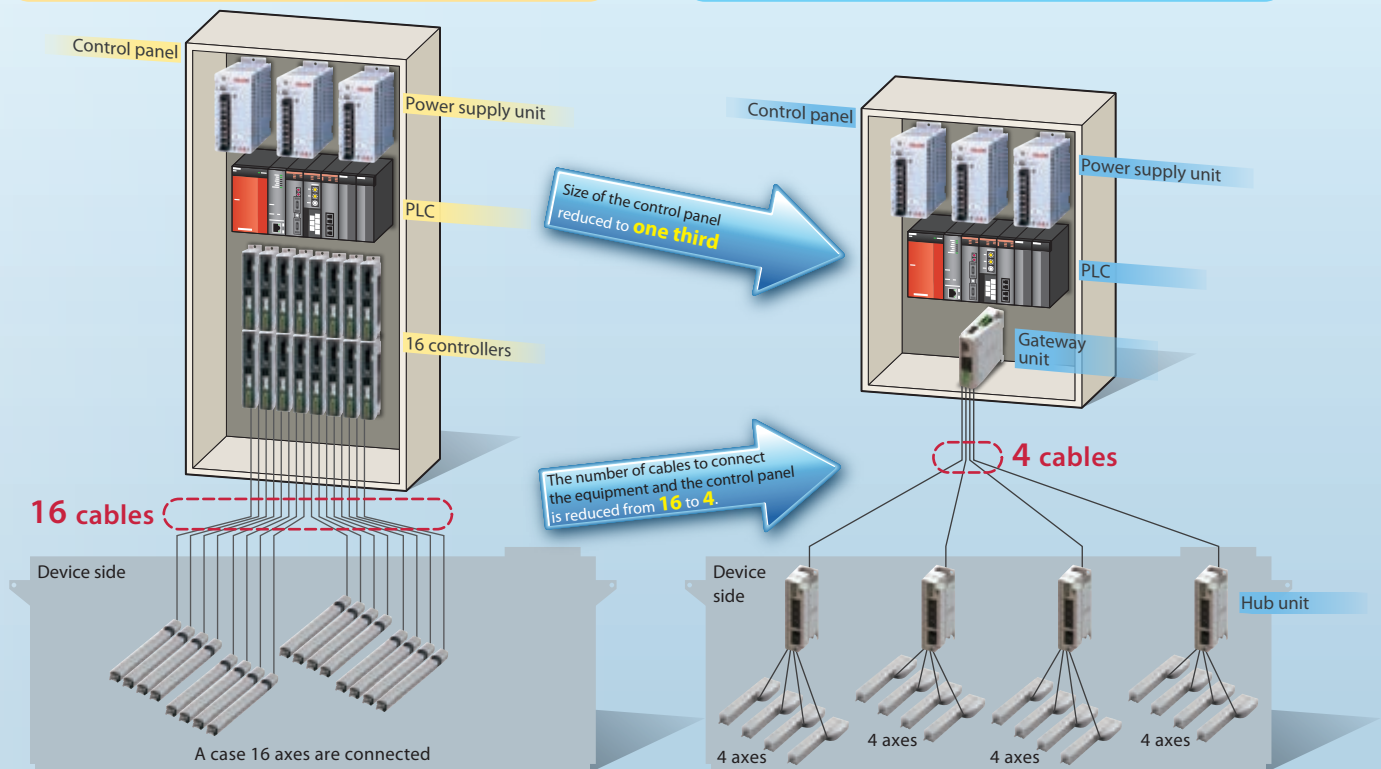

* Maximum cable length between the gateway unit and RCP6S is 20m. If there is a hub unit in between, the maximum length is still 20m. The cable length from the gateway unit to the hub unit needs to be 10m or less.

Applicable Controllers for RCP6 (Standard/Separate Controller Type)

PCON-CB/CFB

Single-axis Position Controller



▶ See P.132 for more details.

Max. number of controlled axes: 1 axis

Max. positioning points: 512 points (for network spec, 768 points)

MCON-C

Multi-axis Position Controller



Max. number of controlled axes: 8 axes

Max. positioning points: 256 points

* Max. number of controlled axes is 4 axes when connected to RCP6.

MSEL

Multi-axis Program Controller



Max. number of controlled axes: 4 axes

Max. positioning points: 30000 points

RCP6/RCP6S Series: Models and Features

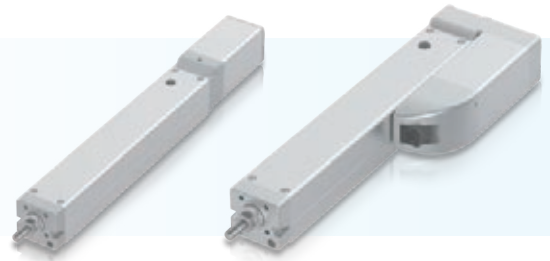

Radial Cylinder: **RRA**

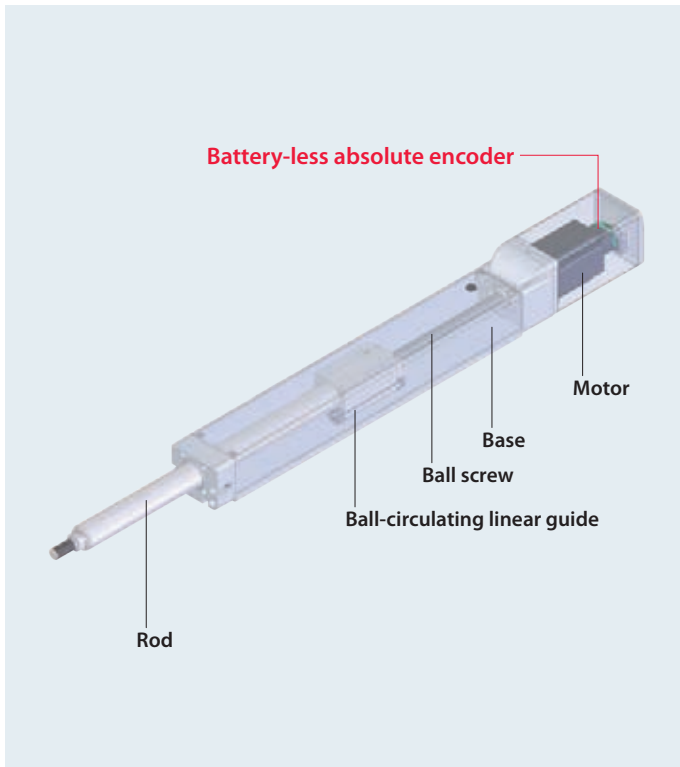

Features

- ▶ Since ball circulating linear guides are built in, it can take radial loads and moment loads. The vibration upon stopping can be suppressed and a long stroke of up to 700mm has become possible. In addition, product quality has significantly increased with a non-rotating rod precision of "0 degree" with a no load condition.
- ▶ The equipment will be compact since an external guide is unnecessary.

Usage examples

- Inserting, press-fitting, or riveting a work
- Using as a lifter or a work piece unloader
- Using as a movable vertical axis of the cartesian system
- Transferring or positioning a lightweight object

Rod Type: **RA**

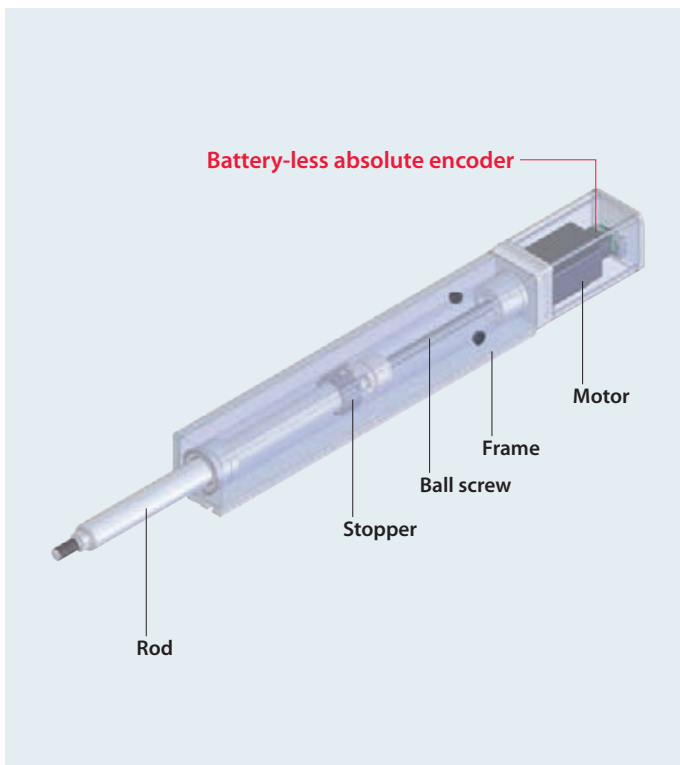

Features

- ▶ This is a type that does not build in a linear guide inside of the actuator. Of the RCP6 rod-types that resemble air cylinders, this is the least expensive model.

Usage examples

- Switching from rod type air cylinder
- Push force combined with a guide
- Inserting, press-fitting, or riveting a work
- Using as a lifter or a work piece unloader

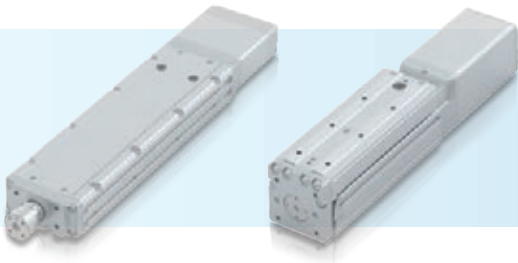

Wide Radial Cylinder: WRA

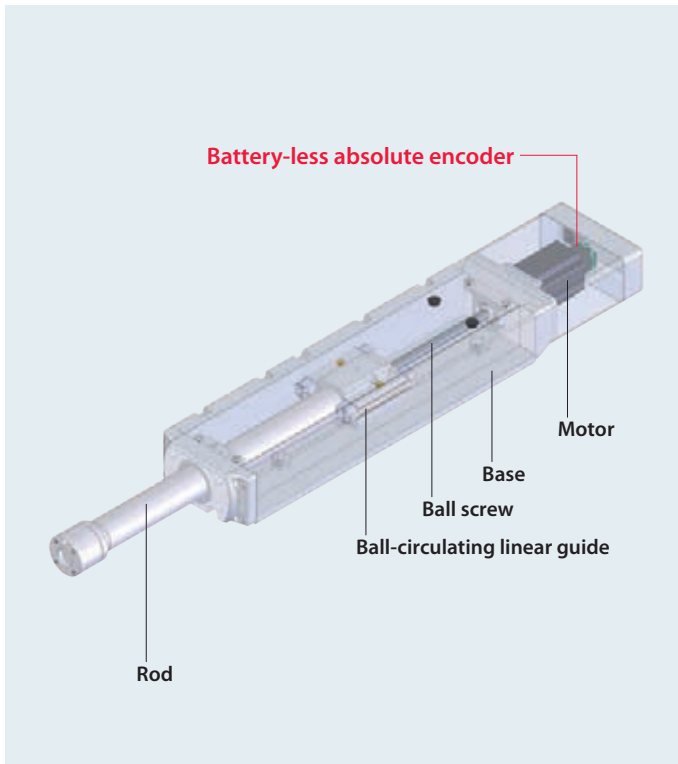

Features

- ▶ Due to a wide body and high-rigidity rod, it can deal with up to four times the allowable torque on rod tip compared to a standard radial cylinder. Due to a high dynamic allowable moment, it can be utilized for uses such as tightening screws and stirring that have large load torque.
- ▶ The equipment will be compact since an external guide is unnecessary.

Usage examples

- Inserting, press-fitting, or riveting a work
- Tightening a screw or stirring
- Using as a lifter or a work piece unloader
- Using as a movable vertical axis of the cartesian system
- Transferring or positioning a lightweight object
- Using as a base axis of the pick-and-place unit

Table Type: TA

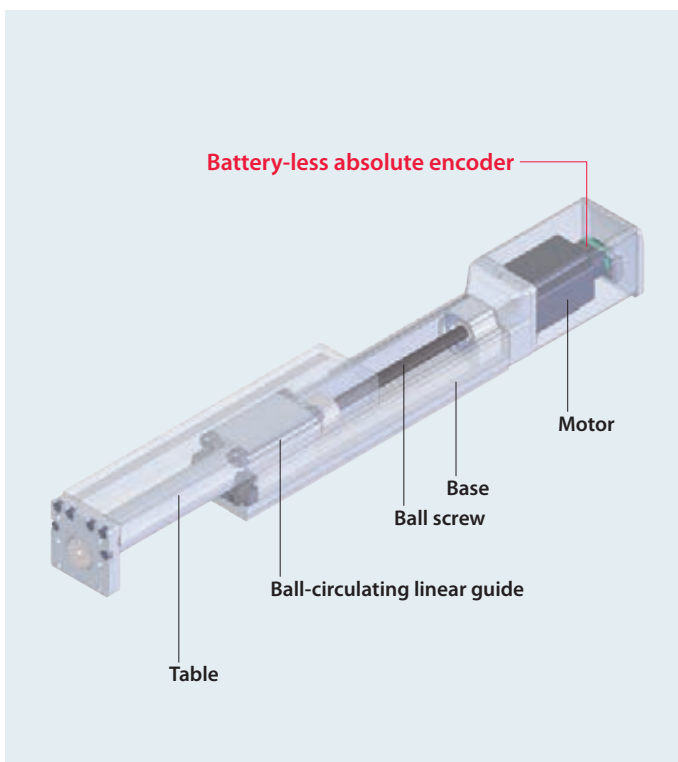

Features

- ▶ Work piece can be installed using the tapped mounting holes on the top surface of the table and the tip plate.
- ▶ With a built-in ball circulating linear guide in the table section, it will be able to deal with moments in the pitching (M_a), yawing (M_b), and rolling (M_c) directions.
- ▶ High-rigidity specification (double-block) can be selected as an option. With two guide blocks, the dynamic allowable moment increases by up to 4.3 times in the pitching (M_a) and yawing (M_b) directions.

Usage examples

- Switching from table type air cylinder
- Clamping tasks that pinch work from both sides
- Positioning tasks that hold work with the front side of the table
- A function for pushing works on a conveyor to the side
- Using as a movable vertical axis of the cartesian system

RCP6/RCP6S Series: Models and Features

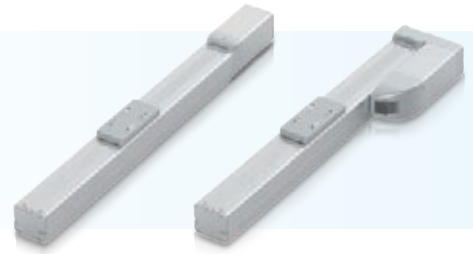

Slider Type: SA

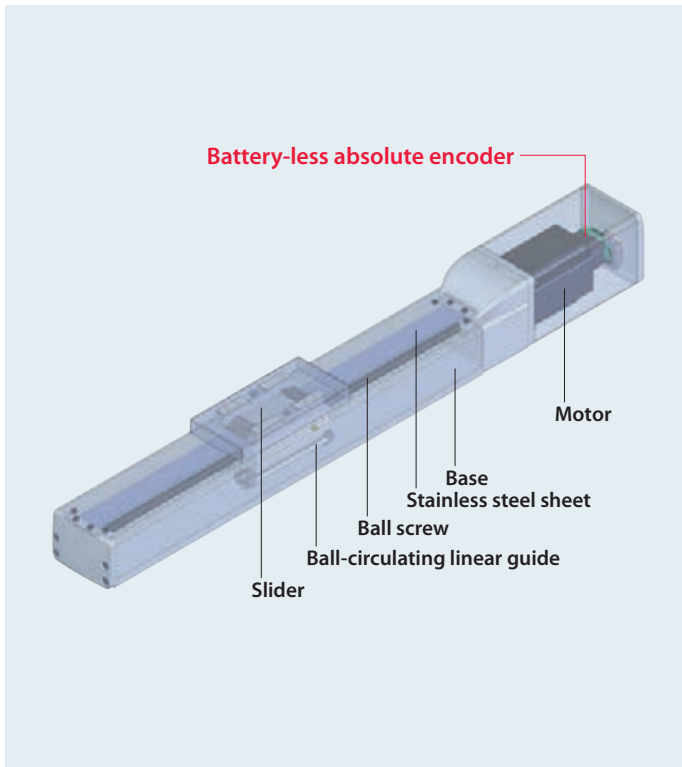

Features

- ▶ With a base integrated ball circulating linear guide, it will be able to deal with moments in the pitching (Ma), yawing (Mb), and rolling (Mc) directions.
- ▶ By combining multiple axes, two-dimensional and three-dimensional operations are possible.

Usage examples

- Switching from rod-less air cylinder
- Switching from self-made equipment with ballscrew, guide, and motor.
- Using as base and movable axes of the cartesian system.
- Work such as assembly, inspection, and measuring length that require high accuracy.

Wide Slider Type: WSA

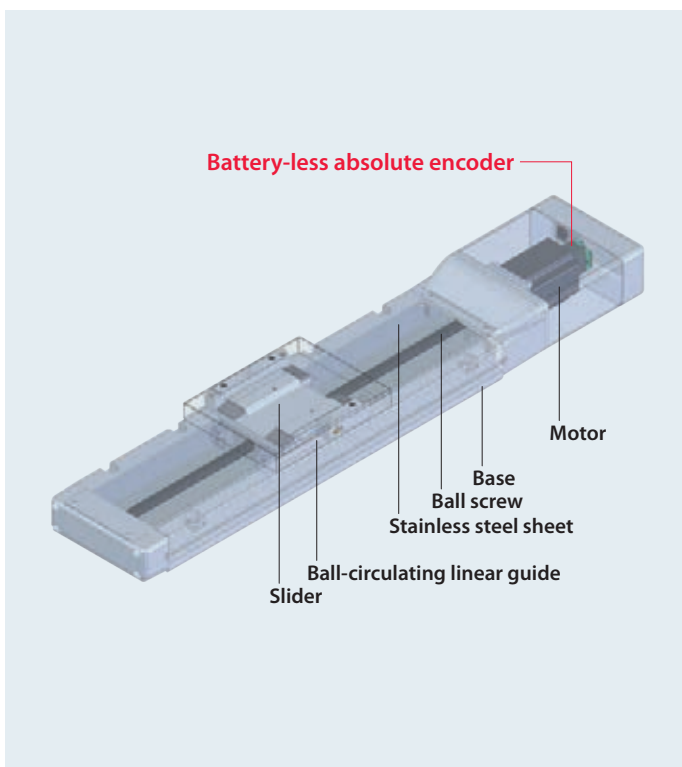

Features

- ▶ Perfect for the base axis of the cartesian system. With a built-in ball circulating linear guide inside its wide body, it will be able to deal with moments in the pitching (Ma), yawing (Mb), and rolling (Mc) directions.
- ▶ 2nd axis can be installed onto the wide slider type without removing its stainless steel sheet.
- ▶ By combining multiple axes, two-dimensional and three-dimensional operations are possible.

Usage examples

- Switching from rod-less air cylinder
- Switching from self-made equipment with ballscrew, guide, and motor.
- Work such as assembly, inspection, and measuring length that require high accuracy.

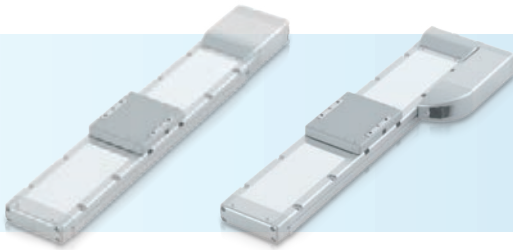

Built-in Controller Type: RCP6S

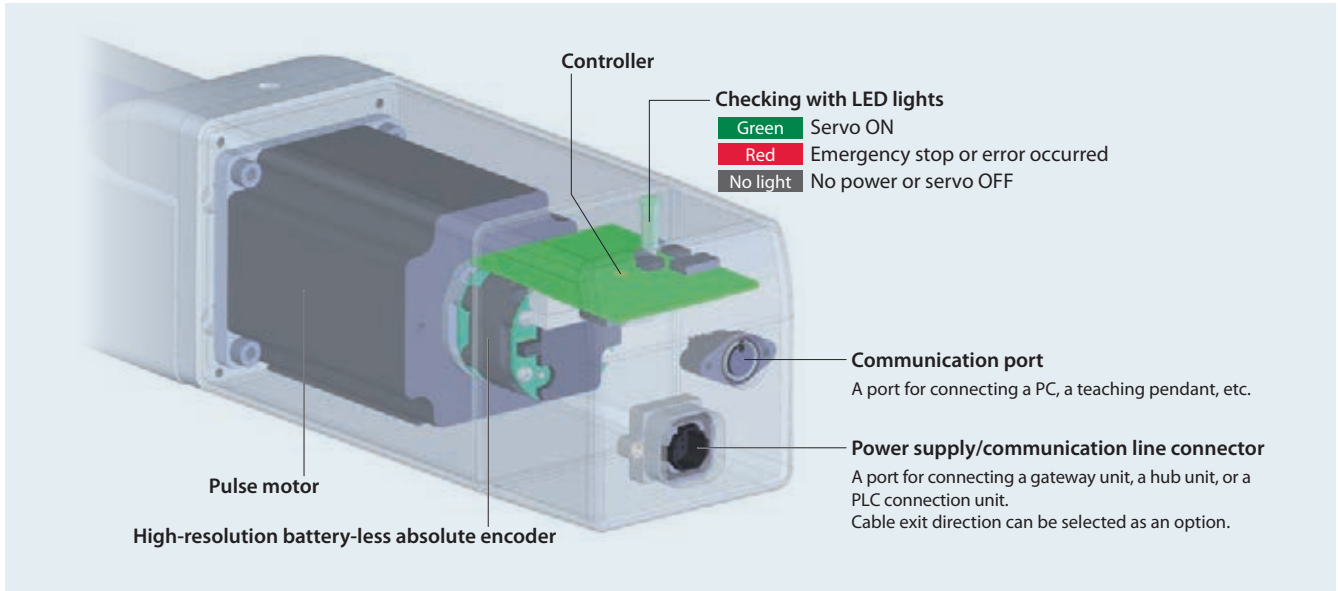

RCP6S Peripheral Equipment

*Gateway unit or PLC connection unit is required to operate the RCP6S.

1 Gateway Unit



- ▶ Compatible field networks
The gate unit can be used with the following 6 types of field networks.

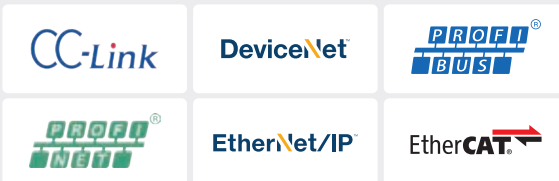

- ▶ 4 RCP6S' or 4 hub units can be connected to a gateway unit.
- ▶ Brake can be forcibly released by supplying power to the brake release input terminal of external power input for each channel. (In the case that the actuator is directly connected)

- ▶ The communication time when RCP6S is connected directly is 10ms, while it is 40ms when using the RCP6S with a hub unit. There will be no change in communication time when the number of connected actuators is increased.

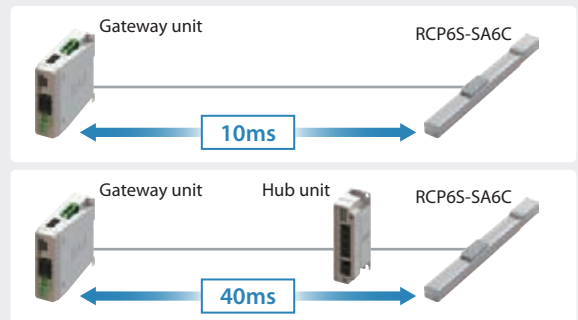

2 Hub Unit



- ▶ A hub unit is a signal distribution unit used by combining with a gateway unit.
- ▶ A gateway unit and a hub unit, or a hub unit and a RCP6 are each connected with a serial communication.
- ▶ A maximum of 4 RCP6S' can be connected.
- ▶ By operating the brake release switch, ON/OFF actions of the brake can be performed.

3 PLC Connection Unit



- ▶ A PLC connection unit is a unit to be moved with serial communication from a master controller or a PLC by combining it with RCP6S.
- ▶ A RCP6S and a PLC connection unit can be connected with a cable with connectors.

Product Lineup

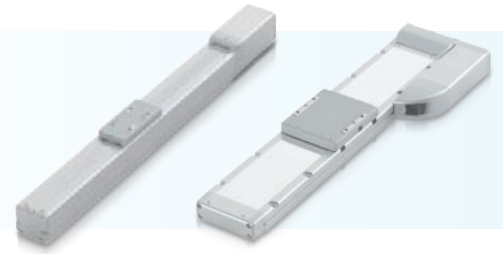

Slider Type: SA

Motor	Type	External View	Body Width (mm)	Lead (mm)	Positioning Repeatability (mm)	Stroke (mm)	Max. Speed (mm/s)	Max. Payload (kg)		Reference Page
								Horizontal	Vertical	
Coupled Motor	SA4C			16	±0.01	50~500 (50mm increments)	1260	7	1.5	p.13
				10			785	12	3	
				5			390	14	5.5	
				2.5			195	18	12	
	SA6C			20	±0.01	50~800 (50mm increments)	1440 <1280>	15	1	p.15
				12			900	28	2.5	
				6			450	32	6	
				3			225	40	16	
	SA7C			24	±0.01	50~800 (50mm increments)	1200	37	3	p.17
				16			980 <840>	46	8	
				8			490	51	16	
				4			245 <210>	55	25	
SA8C			30	±0.01	50~1100 (50mm increments)	1200 <850>	28	3	p.19	
			20			1000 <800>	60	4		
			10			500	70	25		
			5			250	80	55		
Side-mounted Motor	SA4R			16	±0.01	50~500 (50mm increments)	1260 <1120>	7	1.5	p.21
				10			785	12	3	
				5			390	14	5.5	
				2.5			195	18	12	
	SA6R			20	±0.01	50~800 (50mm increments)	1280 <1120>	15	1	p.23
				12			900 <800>	28	2.5	
				6			450	32	6	
				3			225	40	14	
	SA7R			24	±0.01	50~800 (50mm increments)	1080	37	3	p.25
				16			840 <700>	46	8	
				8			420	51	16	
				4			210	55	25	
SA8R			30	±0.01	50~1100 (50mm increments)	1200 <850>	26	3	p.27	
			20			1000 <800>	55	4		
			10			500 <450>	70	25		
			5			250	80	55		

Values in brackets < > are for vertical use. Values in brackets [] are for high-precision specification.

Wide Slider Type: WSA

Motor	Type	External View	Body Width (mm)	Lead (mm)	Positioning Repeatability (mm)	Stroke (mm)	Max. Speed (mm/s)	Max. Payload (kg)		Reference Page
								Horizontal	Vertical	
Coupled Motor	WSA10C			16	±0.01	50~500 (50mm increments)	840	4	-	p.29
				10			610	15	-	
				5			390 <350>	28	3	
				2.5			195 <175>	40	10	
	WSA12C			20	±0.01	50~800 (50mm increments)	800	12	-	p.31
				12			600	25	-	
				6			450 <400>	40	9	
				3			225	60	18	
	WSA14C			24	±0.01	50~800 (50mm increments)	700	25	-	p.33
				16			560	50	-	
				8			420 <350>	65	14	
				4			210 <175>	80	26	
WSA16C			20	±0.01	50~1100 (50mm increments)	720	50	-	p.35	
			10			450 <240>	70	15		
			5			195 <170>	100	50		
Side-mounted Motor	WSA10R			16	±0.01	50~500 (50mm increments)	840	4	-	p.37
				10			610	15	-	
				5			390 <305>	28	3	
				2.5			195 <175>	40	10	
	WSA12R			20	±0.01	50~800 (50mm increments)	800	12	-	p.39
				12			600	25	-	
				6			450 <400>	40	9	
				3			225	60	16	
	WSA14R			24	±0.01	50~800 (50mm increments)	700	25	-	p.41
				16			560	50	-	
				8			420 <350>	65	14	
				4			175	80	26	
WSA16R			20	±0.01	50~1100 (50mm increments)	600	30	-	p.43	
			10			365 <210>	70	15		
			5			170 <145>	100	45		

Values in brackets < > are for vertical use. Values in brackets [] are for high-precision specification.

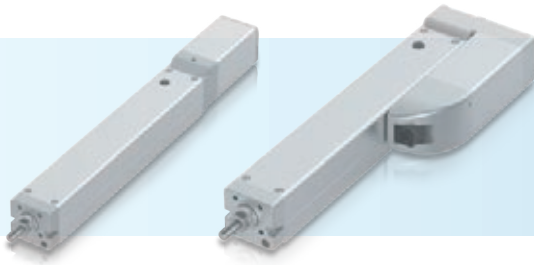

Rod Type: RA

Motor	Type	External View	Body Width (mm)	Lead (mm)	Positioning Repeatability (mm)	Stroke (mm)	Max. Speed (mm/s)	Max. Push Force (N)	Max. Payload (kg)		Reference Page
									Horizontal	Vertical	
Coupled Motor	RA4C			16	±0.01	50~200 (50mm increments)	840	48	6	1.5	p.45
				10			700	77	15	2.5	
				5			350	155	28	5	
				2.5			175	310	40	10	
	RA6C			20	±0.01	50~300 (50mm increments)	800	56	6	1.5	p.47
				12			700	93	25	4	
				6			450	185	40	10	
				3			225	370	60	20	
	RA7C			24	±0.01	50~300 (50mm increments)	860 <640>	182	20	3	p.49
				16			700 <560>	273	50	8	
				8			420 <350>	547	60	18	
				4			210 <175>	1094	80	28	
RA8C			20	±0.01	50~300 (50mm increments)	600 <450>	500	30	5	p.51	
			10			300 <250>	1000	60	40		
			5			150	2000	100	70		
Side-mounted Motor	RA4R			16	±0.01	50~200 (50mm increments)	840	48	5	1	p.53
				10			610	77	12	2.5	
				5			350	155	25	5	
				2.5			175	310	40	10	
	RA6R			20	±0.01	50~300 (50mm increments)	800	56	6	1.5	p.55
				12			700	93	25	4	
				6			450	185	40	10	
				3			225	370	60	20	
	RA7R			24	±0.01	50~300 (50mm increments)	800 <640>	182	20	3	p.57
				16			560	273	50	8	
				8			420 <350>	547	60	18	
				4			175	1094	80	28	
RA8R			20	±0.01	50~300 (50mm increments)	400	500	30	5	p.59	
			10			200	1000	60	40		
			5			100	2000	100	70		

Values in brackets < > are for vertical use.

Radial Cylinder: RRA

Motor	Type	External View	Body Width (mm)	Lead (mm)	Positioning Repeatability (mm)	Stroke (mm)	Max. Speed (mm/s)	Max. Push Force (N)	Max. Payload (kg)		Reference Page
									Horizontal	Vertical	
Coupled Motor	RRA4C			16	±0.01	60~410 (50mm increments)	1120	48	7	1.5	p.61
				10			700	77	18	3	
				5			350	155	28	6	
				2.5			175	310	40	10	
	RRA6C			20	±0.01	65~415 (50mm increments)	800	56	6	1.5	p.63
				12			700	93	25	4	
				6			450	185	40	10	
				3			225	370	60	20	
	RRA7C			24	±0.01	70~520 (50mm increments)	860 <640>	182	20	3	p.65
				16			700 <560>	273	50	8	
				8			420	547	60	18	
				4			210	1094	80	28	
RRA8C			20	±0.01	50~700 (50mm increments)	600 <450>	500	30	5	p.67	
			10			300 <250>	1000	60	40		
			5			150	2000	100	70		
Side-mounted Motor	RRA4R			16	±0.01	60~410 (50mm increments)	840	48	5	1	p.69
				10			610	77	13	2.5	
				5			350	155	28	5	
				2.5			175	310	40	10	
	RRA6R			20	±0.01	65~415 (50mm increments)	800	56	6	1.5	p.71
				12			700	93	25	4	
				6			450	185	40	10	
				3			225	370	60	20	
	RRA7R			24	±0.01	70~520 (50mm increments)	860 <640>	182	20	3	p.73
				16			560	273	50	8	
				8			420 <350>	547	60	18	
				4			175	1094	80	28	
RRA8R			20	±0.01	50~700 (50mm increments)	400	500	30	5	p.75	
			10			200	1000	60	40		
			5			100	2000	100	70		

Values in brackets < > are for vertical use.

Product Lineup



Wide Radial Cylinder: WRA

Motor	Type	External View	Body Width (mm)	Lead (mm)	Positioning Repeatability (mm)	Stroke (mm)	Max. Speed (mm/s)	Max. Push Force (N)	Max. Payload (kg)		Reference Page
								Horizontal	Vertical		
Coupled Motor	WRA10C		100mm	16	±0.01	50~500 (50mm increments)	700	48	4	-	p.77
				10			525	77	14.5	-	
				5			350 <260>	155	28	5	
				2.5			175	310	40	10	
	WRA12C		120mm	20	±0.01	50~500 (50mm increments)	800	56	7.5	-	p.79
				12			560	93	30	-	
				6			400 <340>	185	55	7.5	
				3			225 <200>	370	70	17.5	
	WRA14C		140mm	24	±0.01	50~600 (50mm increments)	630	182	25	-	p.81
				16			560	273	50	-	
				8			420 <210>	547	65	15	
				4			210 <130>	1094	85	25	
WRA16C		160mm	20	±0.01	50~800 (50mm increments)	450	500	30	-	p.83	
			10			240 <200>	1000	60	36.5		
			5			130 <100>	2000	100	70		
Side-mounted Motor	WRA10R		100mm	16	±0.01	50~500 (50mm increments)	700	48	4	-	p.85
				10			525	77	11.5	-	
				5			350 <260>	155	28	5	
				2.5			175 <150>	310	40	10	
	WRA12R		120mm	20	±0.01	50~500 (50mm increments)	800	56	7.5	-	p.87
				12			560	93	30	-	
				6			400 <280>	185	55	7.5	
				3			225 <200>	370	70	17.5	
	WRA14R		140mm	24	±0.01	50~600 (50mm increments)	630	182	25	-	p.89
				16			560	273	50	-	
				8			350 <210>	547	65	15	
				4			175 <130>	1094	85	25	
WRA16R		160mm	20	±0.01	50~800 (50mm increments)	420	500	30	-	p.91	
			10			240 <180>	1000	60	34.5		
			5			120 <100>	2000	100	63		

Values in brackets < > are for vertical use.

Table Type: TA

Motor	Type	External View	Body Width (mm)	Lead (mm)	Positioning Repeatability (mm)	Stroke (mm)	Max. Speed (mm/s)	Max. Payload (kg)		Reference Page	
								Horizontal	Vertical		
Motor Coupled Motor	TA4C		40mm	16 (*)	±0.01	SB Spec: 25~150 (25mm increments) DB Spec: 40, 65, 90, 140, 190, 240	980 <700>	3[-]	1[-]	p.93	
				10			785 <700>	4[8]	2.5[2.5]		
				5			390	5[10]	5[5]		
				2.5			195	5[10]	10[10]		
	TA6C		58mm	20 (*)	±0.01	SB Spec: 25~200 (25mm increments) DB Spec: 45, 70, 95, 120~320 (50mm increments)	1120 <800>	5[-]	1[-]	p.95	
				12			800[800<680>]	8[15]	3[3]		
				6			400	10[20]	6[6]		
				3			200	10[20]	12[12]		
	TA7C		70mm	24 (*)	±0.01	SB Spec: 25~300 DB Spec: 40, 65, 90~390 (50mm increments)	1080 <860>	10[-]	3[-]	p.97	
				16			700 <560>	12[25]	7[7]		
				8			420 <350>	15[30]	16[16]		
				4			210	15[30]	20[24]		
Side-mounted Motor	TA4R		40mm	16 (*)	±0.01	SB Spec: 25~150 (25mm increments) DB Spec: 40, 65, 90, 140, 190, 240	980 <700>	3[-]	1[-]	p.99	
				10			785 <700>[700<525>]	4[8]	2.5[2.5]		
				5			390	5[10]	5[5]		
				2.5			195	5[10]	10[10]		
	TA6R		58mm	20 (*)	±0.01	SB Spec: 25~200 (25mm increments) DB Spec: 45, 70, 95, 120~320 (50mm increments)	1120 <800>	5[-]	1[-]	p.101	
				12			800 <680>	8[15]	3[3]		
				6			400	10[20]	6[6]		
				3			200	10[20]	12[12]		
	TA7R		70mm	24 (*)	±0.01	SB Spec: 25~300 (25mm increments) DB Spec: 40, 65, 90~390 (50mm increments)	1080 <860>	10[-]	3[-]	p.103	
				16			700 <560>	12[25]	7[7]		
				8			420 <350>	15[30]	16[16]		
				4			210	15[30]	20[24]		

(*) Only single-block (SB) specification.

Values in brackets < > are for vertical use. Values in brackets [] are for the double-block (DB) specification.

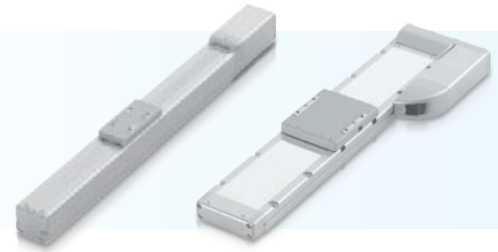

Model Specification Items

Slider Type: SA

Series	Type	Encoder Type	Motor Type	Ball Screw Lead	Stroke	Applicable Controller (RCP6)	I/O Type (RCP6S)	Cable Length	Options
RCP6 RCP6S	Standard (Separate controller) Built-in controller	WA Battery-less absolute	35P 35□ Pulse motor 42P 42□ Pulse motor 56P 56□ Pulse motor 56SP 56□ Pulse motor	2.5 2.5mm 3 3mm 4 4mm 5 5mm 6 6mm 8 8mm 10 10mm 12 12mm 16 16mm 20 20mm 24 24mm 30 30mm	50 50mm 1100 1100mm <small>(Can be set in 50mm increments)</small>	P3 PCON-CB/CGB MCON MSEL P4 PCON-CFB/CGFB	SE SIO Type	N None P 1m S 3m M 5m X□□ Specified length R□□ Robot cable	B Brake CJT Cable exit direction (Top) CJR Cable exit direction (Right) CJL Cable exit direction (Left) CJO Cable exit direction (Outside) CJB Cable exit direction (Bottom) ML Motor side-mounted to the left MR Motor side-mounted to the right NM Non-motor end specification SS Slider spacer HPR High-precision specification SR Slider roller specification W Double slider
SA4C	Body width 40mm Coupled motor type								
SA6C	Body width 58mm Coupled motor type								
SA7C	Body width 70mm Coupled motor type								
SA8C	Body width 85mm Coupled motor type								
SA4R	Body width 40mm Side-mounted motor type								
SA6R	Body width 58mm Side-mounted motor type								
SA7R	Body width 70mm Side-mounted motor type								
SA8R	Body width 85mm Side-mounted motor type								

*The type of motor, ball screw lead, stroke, and options vary depending on the actuator type. Please refer to the pages of each type for details.

Wide Slider Type: WSA

Series	Type	Encoder Type	Motor Type	Ball Screw Lead	Stroke	Applicable Controller (RCP6)	I/O Type (RCP6S)	Cable Length	Options
RCP6 RCP6S	Standard (Separate controller) Built-in controller	WA Battery-less absolute	35P 35□ Pulse motor 42P 42□ Pulse motor 56P 56□ Pulse motor 56SP 56□ Pulse motor	2.5 2.5mm 3 3mm 4 4mm 5 5mm 6 6mm 8 8mm 10 10mm 12 12mm 16 16mm 20 20mm 24 24mm	50 50mm 1100 1100mm <small>(Can be set in 50mm increments)</small>	P3 PCON-CB/CGB MCON MSEL P4 PCON-CFB/CGFB	SE SIO Type	N None P 1m S 3m M 5m X□□ Specified length R□□ Robot cable	B Brake CJT Cable exit direction (Top) CJR Cable exit direction (Right) CJL Cable exit direction (Left) CJO Cable exit direction (Outside) CJB Cable exit direction (Bottom) ML Motor side-mounted to the left MR Motor side-mounted to the right NM Non-motor end specification HPR High-precision specification SR Slider roller specification
WSA10C	Body width 100mm Coupled motor type								
WSA12C	Body width 120mm Coupled motor type								
WSA14C	Body width 140mm Coupled motor type								
WSA16C	Body width 160mm Coupled motor type								
WSA10R	Body width 100mm Side-mounted motor type								
WSA12R	Body width 120mm Side-mounted motor type								
WSA14R	Body width 140mm Side-mounted motor type								
WSA16R	Body width 160mm Side-mounted motor type								

*The type of motor, ball screw lead, stroke, and options vary depending on the actuator type. Please refer to the pages of each type for details.

Model Specification Items

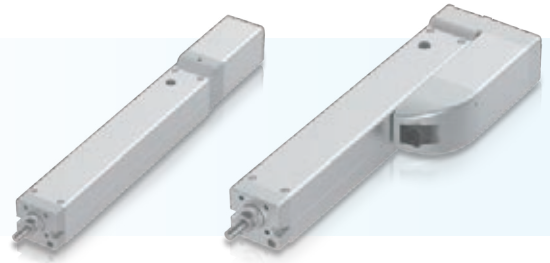

Rod Type: RA

Series	Type	Encoder Type	Motor Type	Ball Screw Lead	Stroke	Applicable Controller (RCP6)	I/O Type (RCP65)	Cable Length	Options
RCP6	Standard (Separate controller)	WA	Battery-less absolute				SE		
RCP6S	Built-in controller								
RA4C	Body width 40mm Coupled motor type	35P	35□ Pulse motor	2.5	2.5mm	P3	SE	N	
RA6C	Body width 58mm Coupled motor type	42P	42□ Pulse motor	3	3mm	P3	SE	P	
RA7C	Body width 70mm Coupled motor type	56P	56□ Pulse motor	4	4mm	P3	SE	S	
RA8C	Body width 85mm Coupled motor type	60P	60□ Pulse motor	5	5mm	P3	SE	M	
RA4R	Body width 40mm Side-mounted motor type			6	6mm	P4	SE	X□□	
RA6R	Body width 58mm Side-mounted motor type			8	8mm	P4	SE	R□□	
RA7R	Body width 70mm Side-mounted motor type			10	10mm				
RA8R	Body width 85mm Side-mounted motor type			12	12mm				
				16	16mm				
				20	20mm				
				24	24mm				

(Can be set in 50mm increments)

When RCP6 (separate controller type) is selected, please pick a code for the applicable controller, and when RCP6S (built-in controller type) is selected, please pick a code for the I/O type.

N	None
P	1m
S	3m
M	5m
X□□	Specified length
R□□	Robot cable

B	Brake
CJT	Cable exit direction (Top)
CJR	Cable exit direction (Right)
CJL	Cable exit direction (Left)
CJO	Cable exit direction (Outside)
CJB	Cable exit direction (Bottom)
FL	Flange
FT	Foot bracket
ML	Motor side-mounted to the left
MR	Motor side-mounted to the right
MT	Motor side-mounted to the top
NFA	Tip adapter (Internal thread)
NM	Non-motor end specification
NTB	T-slot nut bar

*The type of motor, ball screw lead, stroke, and options vary depending on the actuator type. Please refer to the pages of each type for details.

Radial Cylinder: RRA

Series	Type	Encoder Type	Motor Type	Ball Screw Lead	Stroke	Applicable Controller (RCP6)	I/O Type (RCP65)	Cable Length	Options
RCP6	Standard (Separate controller)	WA	Battery-less absolute				SE		
RCP6S	Built-in controller								
RRA4C	Body width 40mm Coupled motor type	35P	35□ Pulse motor	60	60mm	P3	SE	N	
RRA6C	Body width 58mm Coupled motor type	42P	42□ Pulse motor	700	700mm	P3	SE	P	
RRA7C	Body width 70mm Coupled motor type	56P	56□ Pulse motor	3	3mm	P3	SE	S	
RRA8C	Body width 85mm Coupled motor type	60P	60□ Pulse motor	4	4mm	P3	SE	M	
RRA4R	Body width 40mm Side-mounted motor type			5	5mm	P4	SE	X□□	
RRA6R	Body width 58mm Side-mounted motor type			6	6mm	P4	SE	R□□	
RRA7R	Body width 70mm Side-mounted motor type			8	8mm				
RRA8R	Body width 85mm Side-mounted motor type			10	10mm				
				16	16mm				
				20	20mm				
				24	24mm				

(Can be set in 50mm increments)

When RCP6 (separate controller type) is selected, please pick a code for the applicable controller, and when RCP6S (built-in controller type) is selected, please pick a code for the I/O type.

N	None
P	1m
S	3m
M	5m
X□□	Specified length
R□□	Robot cable

B	Brake
CJT	Cable exit direction (Top)
CJR	Cable exit direction (Right)
CJL	Cable exit direction (Left)
CJO	Cable exit direction (Outside)
CJB	Cable exit direction (Bottom)
FL	Flange
FFA	Tip adapter (Flange)
NFA	Tip adapter (Internal thread)
KFA	Tip adapter (Keyway)
ML	Motor side-mounted to the left
MR	Motor side-mounted to the right
NJ	Knuckle joint
QR	Clevis bracket
NM	Non-motor end specification

*The type of motor, ball screw lead, stroke, and options vary depending on the actuator type. Please refer to the pages of each type for details.

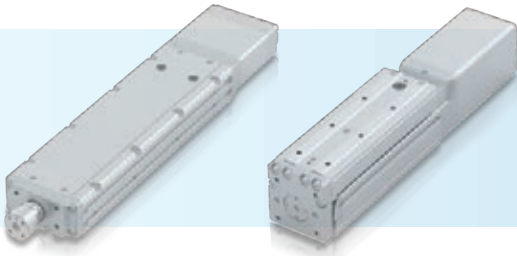

Wide Radial Cylinder: WRA

Series	Type	Encoder Type	Motor Type	Ball Screw Lead	Stroke	Applicable Controller (RCP6)	I/O Type (RCP6S)	Cable Length	Options
RCP6	Standard (Separate controller)	WA	Battery-less absolute			P3	SE	N	
RCP6S	Built-in controller								
WRA10C	Body width 100mm Coupled motor type	35P	35□ Pulse motor	2.5	2.5mm	P3 PCON-CB/CGB MCON MSEL P4 PCON-CFB/CGFB	SE	N None P 1m S 3m M 5m X□□ Specified length R□□ Robot cable	B Brake CJT Cable exit direction (Top) CJR Cable exit direction (Right) CJL Cable exit direction (Left) CJO Cable exit direction (Outside) CJB Cable exit direction (Bottom) FL Flange ML Motor side-mounted to the left MR Motor side-mounted to the right NM Non-motor end specification NTBL T-slot nut bar (Left) NTBR T-slot nut bar (Right)
WRA12C	Body width 120mm Coupled motor type	42P	42□ Pulse motor	3	3mm				
WRA14C	Body width 140mm Coupled motor type	56P	56□ Pulse motor	4	4mm				
WRA16C	Body width 160mm Coupled motor type	60P	60□ Pulse motor	5	5mm				
WRA10R	Body width 100mm Side-mounted motor type			6	6mm				
WRA12R	Body width 120mm Side-mounted motor type			8	8mm				
WRA14R	Body width 140mm Side-mounted motor type			10	10mm				
WRA16R	Body width 160mm Side-mounted motor type			12	12mm				
				16	16mm				
				20	20mm				
				24	24mm				

(Can be set in 50mm increments)

When RCP6 (separate controller type) is selected, please pick a code for the applicable controller, and when RCP6S (built-in controller type) is selected, please pick a code for the I/O type.

*The type of motor, ball screw lead, stroke, and options vary depending on the actuator type. Please refer to the pages of each type for details.

Table Type: TA

Series	Type	Encoder Type	Motor Type	Ball Screw Lead	Stroke	Applicable Controller (RCP6)	I/O Type (RCP6S)	Cable Length	Options
RCP6	Standard (Separate controller)	WA	Battery-less absolute			P3	SE	N	
RCP6S	Built-in controller								
TA4C	Body width 40mm Coupled motor type	35P	35□ Pulse motor	2.5	2.5mm	P3 PCON-CB/CGB MCON MSEL P4 PCON-CFB/CGFB	SE	N None P 1m S 3m M 5m X□□ Specified length R□□ Robot cable	B Brake CJT Cable exit direction (Top) CJR Cable exit direction (Right) CJL Cable exit direction (Left) CJO Cable exit direction (Outside) CJB Cable exit direction (Bottom) DB High-rigidity (Double-block guide) ML Motor side-mounted to the left MR Motor side-mounted to the right NM Non-motor end specification
TA6C	Body width 58mm Coupled motor type	42P	42□ Pulse motor	3	3mm				
TA7C	Body width 70mm Coupled motor type	56P	56□ Pulse motor	4	4mm				
TA4R	Body width 40mm Side-mounted motor type			5	5mm				
TA6R	Body width 58mm Side-mounted motor type			6	6mm				
TA7R	Body width 70mm Side-mounted motor type			8	8mm				
				10	10mm				
				12	12mm				
				16	16mm				
				20	20mm				
				24	24mm				

When RCP6 (separate controller type) is selected, please pick a code for the applicable controller, and when RCP6S (built-in controller type) is selected, please pick a code for the I/O type.

*The type of motor, ball screw lead, stroke, and options vary depending on the actuator type. Please refer to the pages of each type for details.

RCP6(S)-SA4C

±10µm Standard
±5µm High-precision Optional
Simple Dust-proof
Battery-less Absolute
Motor Unit Coupled
Straight Motor
Body Width 40mm
24V Pulse Motor

Model Specification Items	Series	Type	Encoder Type	Motor Type	Lead	Stroke	Applicable Controller/I/O Type	Cable Length	Options
	RCP6: Separate Controller RCP6S: Built-in Controller	SA4C	WA: Battery-less Absolute	35P: Pulse Motor 35□ Size	16: 16mm 10: 10mm 5: 5mm 2.5: 2.5mm	50: 50mm 500: 500mm (50mm increments)	[RCP6] P3: PCON MCON MSEL [RCP6S] SE: SIO Type	N: None P: 1m S: 3m M: 5m X□□: Specified Length R□□: Robot Cable	Please refer to the options table below.

* RCP6 does not include a controller. RCP6S includes a built-in controller.
** Preview: Cleanroom type RCP6(S)CR-SA4C comes later.

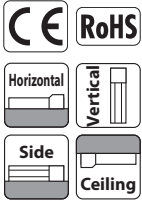

*Depending on the model, there may be some limitations to using the vertical, side, and ceiling mount positions. Please contact IAI for more information regarding mounting positions.



- POINT Selection Notes**
- (1) The maximum acceleration/deceleration is 1G for horizontal, and 0.5G for vertical use.
 - (2) The actuator specification displays the payload's maximum value, but it will vary depending on the acceleration and speed. Please refer to the "Selection Guidelines" (RCP6 Tables of Payload by Speed/Acceleration) on P.115 for more details.
 - (3) When performing push-motion operation, please confirm the push force of each model by checking the "Correlation diagram of push force and current limit" on P.113.

Correlation Diagrams of Speed and Payload

High-output enabled (*) with PCON/MCON/MSEL connected.
RCP6(S)-SA4C Horizontal mount

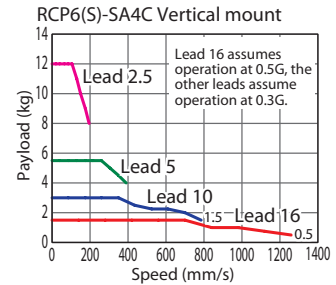
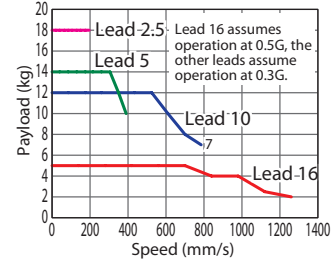

(*) For high output setting to OFF, refer to the RCP6 manual.

Actuator Specifications (*)

(*) For values of disabled high output controller setting refer to the RCP6 manual.

Lead and Payload

Model Number	Lead (mm)	Connected Controller	Max. Payload		Stroke (mm)
			Horizontal (kg)	Vertical (kg)	
RCP6(S)-SA4C-WA-35P-16-①-②-③-④	16	High-output Enabled	7	1.5	50~500 (The increment of stroke is 50mm)
RCP6(S)-SA4C-WA-35P-10-①-②-③-④	10	High-output Enabled	12	3	
RCP6(S)-SA4C-WA-35P-5-①-②-③-④	5	High-output Enabled	14	5.5	
RCP6(S)-SA4C-WA-35P-2.5-①-②-③-④	2.5	High-output Enabled	18	12	

Legend: ① Stroke ② Applicable controller/I/O type ③ Cable length ④ Options

Stroke and Max. Speed

(Unit: mm/s)

Lead (mm)	Connected Controller	50~400 (Every 50mm)	450 (mm)	500 (mm)
16	High-output Enabled	1260	1060	875
10	High-output Enabled	785	675	555
5	High-output Enabled	390	330	275
2.5	High-output Enabled	195	165	135

Cable Length

Cable Type	Cable Code
Standard	P (1m)
	S (3m)
	M (5m)
Specified Length	X06 (6m) ~ X10 (10m)
	X11 (11m) ~ X15 (15m)
	X16 (16m) ~ X20 (20m)
Robot Cable	R01 (1m) ~ R03 (3m)
	R04 (4m) ~ R05 (5m)
	R06 (6m) ~ R10 (10m)
	R11 (11m) ~ R15 (15m)
	R16 (16m) ~ R20 (20m)

* Refer to P.144 for more information regarding the maintenance cables.

Options

Name	Option Code	Reference Page
Brake	B	See P.105
Cable exit direction (Top)	CJT	See P.105
Cable exit direction (Right)	CJR	See P.105
Cable exit direction (Left)	CJL	See P.105
Cable exit direction (Bottom)	CJB	See P.105
High-precision specification (*1)	HPR	See P.108
Non-motor end specification	NM	See P.110
Slider roller specification	SR	See P.111
Double slider (*2)	W	See P.112

Actuator Specifications

Item	Description
Drive system	Ball screw ø8mm, rolled C10
Positioning repeatability (*1)	±0.01mm [±0.005mm]
Lost motion	0.1mm or less
Base	Material: Aluminum with white alumite treatment
Static allowable moment	Ma: 13.0N·m, Mb: 18.6N·m, Mc: 25.3N·m
Dynamic allowable moment (*2)	Ma: 5.0N·m, Mb: 7.1N·m, Mc: 9.7N·m
Ambient operating temp. & humidity	0~40°C, 85% RH or less (Non-condensing)

(*1) Values in [] are for high-precision (for lead 2.5/5/10) specification.
(*2) Assumes a standard rated life of 5000km. The service life will vary depending on operation and installation conditions.

• Reference for overhang load length: Ma: 150mm or less, Mb, Mc: 150mm or less

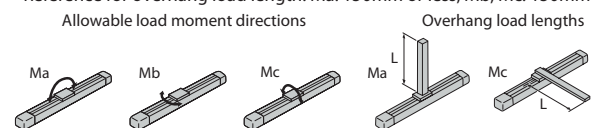

Please refer to the RoboCylinder General Catalog for more information regarding the directions of the allowable moment and overhang load length.

(*1) Positioning repeatability is ±5µm for high-precision specification (HPR).

High-precision specification option cannot be selected for lead 16 and cannot be selected together with the double slider option.

(*2) This option is not available with some combination of the leads and mounting positions. Please refer to P.131 for more information.

Dimensions

CAD drawings can be downloaded from our website.
www.robocylinder.de



*1 When the slider is returning to its home position, please be careful of interference from surrounding objects, as it will travel until it reaches the M.E.
M.E: Mechanical end S.E: Stroke end

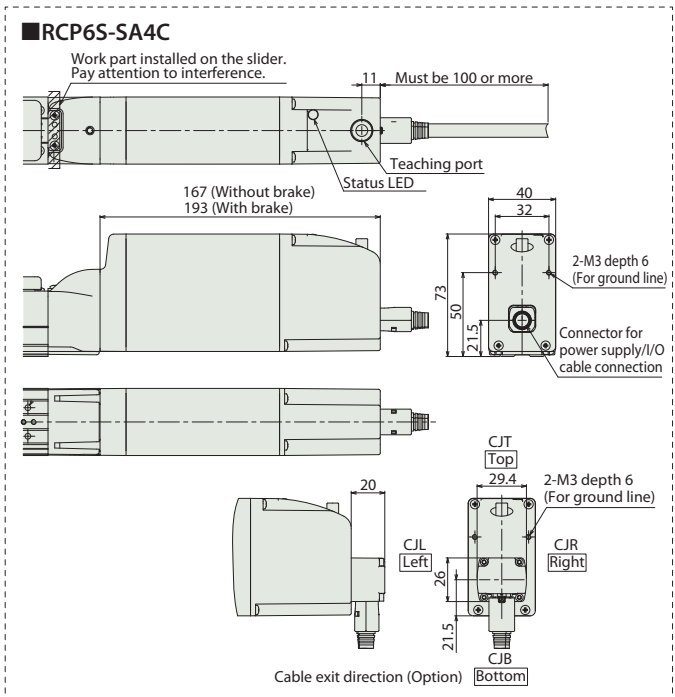
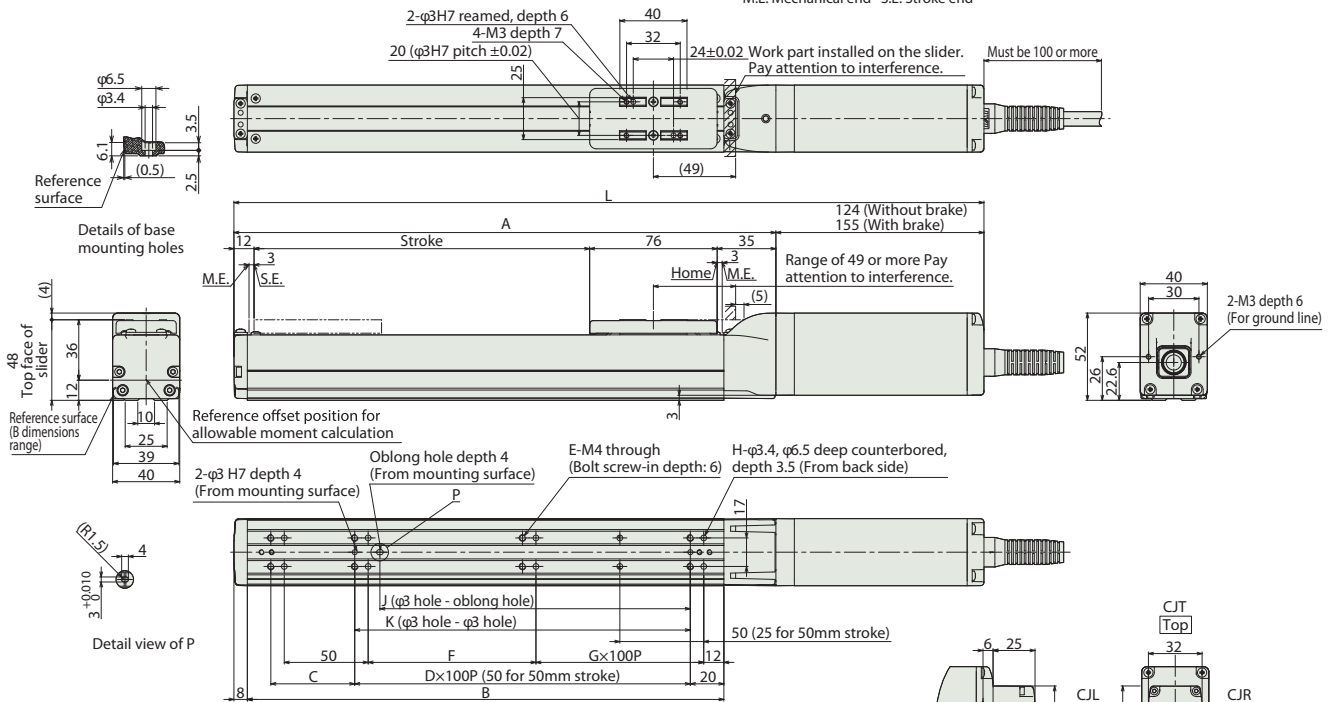

■ Dimensions and Mass by Stroke

Stroke	50	100	150	200	250	300	350	400	450	500		
L	RCP6	w/o brake	297	347	397	447	497	547	597	647	697	747
		w/ brake	328	378	428	478	528	578	628	678	728	778
	RCP6S	w/o brake	340	390	440	490	540	590	640	690	740	790
		w/ brake	366	416	466	516	566	616	666	716	766	816
A	173	223	273	323	373	423	473	523	573	623		
B	134	184	234	284	334	384	434	484	534	584		
C	50	50	100	50	100	50	100	50	100	50		
D	-	1	1	2	2	3	3	4	4	5		
E	6	6	6	8	8	10	10	12	12	14		
F	50	100	50	100	50	100	50	100	50	100		
G	0	0	1	1	2	2	3	3	4	4		
H	8	8	10	10	12	12	14	14	16	16		
J	35	85	85	185	185	285	285	385	385	485		
K	50	100	100	200	200	300	300	400	400	500		
Mass (kg)	RCP6	w/o brake	1.1	1.2	1.3	1.4	1.5	1.6	1.7	1.7	1.8	1.9
		w/ brake	1.3	1.4	1.5	1.5	1.6	1.7	1.8	1.9	2.0	2.1
	RCP6S	w/o brake	1.3	1.4	1.5	1.6	1.7	1.8	1.8	1.9	2.0	2.1
		w/ brake	1.5	1.6	1.6	1.7	1.8	1.9	2.0	2.1	2.2	2.3

Applicable Controllers

The RCP6 series actuators can be operated by the controllers indicated below. Please select the type depending on your intended use. * Please refer to P.147 for more information about the built-in controller of RCP6S series.

Name	External view	Max. number of controlled axes	Input power	Control method				Maximum number of positioning points	Reference page
				Positioner	Pulse train	Program	Network *Option		
PCON-CB/CGB		1	DC24V	● *Option	● *Option	-	 	512 (768 for network spec.)	Please see P.132
MCON-C/CG		4		This model is network-compatible only.					
MSEL-PC/PG		4	Single-phase 100~230VAC	-	-	●		30000	Please see the MSEL-PC/PG catalog or manual.

* Please select "high-output specification" as an option for the MCON. With the MCON, operation is possible only when the high-output specification is selected.

RCP6(S)-SA6C



Model Specification Items	Series	Type	Encoder Type	Motor Type	Lead	Stroke	Applicable Controller/I/O Type	Cable Length	Options
	SA6C	WA	42P						
	RCP6: Separate Controller RCP6S: Built-in Controller	WA: Battery-less Absolute	42P: Pulse Motor 42□ Size	20: 20mm 12: 12mm 6: 6mm 3: 3mm	50: 50mm 800: 800mm (50mm increments)	[RCP6] P3: PCON MCON MSEL [RCP6S] SE: SIO Type	N : None P : 1m S : 3m M : 5m X□ : Specified Length R□ : Robot Cable	Please refer to the options table below.	

* RCP6 does not include a controller. RCP6S includes a built-in controller.
** Preview: Cleanroom type RCP6(S)CR-SA6C comes later.

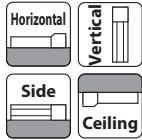

*Depending on the model, there may be some limitations to using the vertical, side, and ceiling mount positions. Please contact IAI for more information regarding mounting positions.



- POINT Selection Notes**
- (1) The maximum acceleration/deceleration is 1G for horizontal, and 0.5G for vertical use.
 - (2) The actuator specification displays the payload's maximum value, but it will vary depending on the acceleration and speed. Please refer to the "Selection Guidelines" (RCP6 Tables of Payload by Speed/Acceleration) on P.115 for more details.
 - (3) When performing push-motion operation, please confirm the push force of each model by checking the "Correlation diagram of push force and current limit" on P.113.
 - (4) Depending on the ambient operational temperature, duty control is necessary for the RCP6S (built-in controller type) with lead 3/6. Please refer to P.130 for more information.

Correlation Diagrams of Speed and Payload

High-output enabled (*) with PCON/MCON/MSEL connected.
RCP6(S)-SA6C Horizontal mount

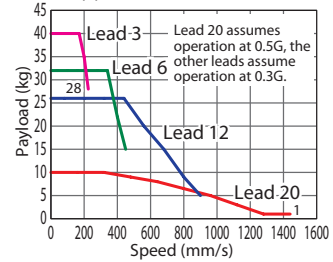

RCP6(S)-SA6C Vertical mount

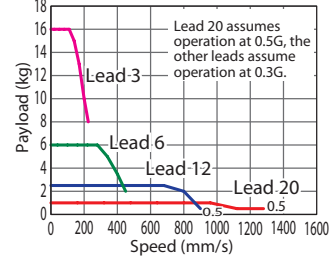

(*) For high output setting to OFF refer to the RCP6 manual.

Actuator Specifications (*)

(*) For values of disabled high output controller setting refer to the RCP6 manual.

Lead and Payload

Model Number	Lead (mm)	Connected Controller	Max. Payload (kg)		Stroke (mm)
			Horizontal	Vertical	
RCP6(S)-SA6C-WA-42P-20-①-②-③-④	20	High-output Enabled	15	1	50~800 (The increment of stroke is 50mm)
RCP6(S)-SA6C-WA-42P-12-①-②-③-④	12	High-output Enabled	28	2.5	
RCP6(S)-SA6C-WA-42P-6-①-②-③-④	6	High-output Enabled	32	6	
RCP6(S)-SA6C-WA-42P-3-①-②-③-④	3	High-output Enabled	40	16	

Legend: ① Stroke ② Applicable controller/I/O type ③ Cable length ④ Options

Stroke and Max. Speed

(Unit: mm/s)

Lead (mm)	Connected Controller	Max. Speed (mm/s)							
		50~400 (Every 50mm)	450 (mm)	500 (mm)	550 (mm)	600 (mm)	650 (mm)	700 (mm)	750 (mm)
20	High-output Enabled	1440 <1280>	1335 <1280>	1130	970	840	735	650	575
12	High-output Enabled	900	885	735	620	535	460	405	315
6	High-output Enabled	450	435	365	305	265	230	200	175
3	High-output Enabled	225	215	180	150	130	115	100	85

Values in brackets < > are for vertical use.

Cable Length

Cable Type	Cable Code
Standard	P (1m)
	S (3m)
	M (5m)
Specified Length	X06 (6m) ~ X10 (10m)
	X11 (11m) ~ X15 (15m)
	X16 (16m) ~ X20 (20m)
	R01 (1m) ~ R03 (3m)
Robot Cable	R04 (4m) ~ R05 (5m)
	R06 (6m) ~ R10 (10m)
	R11 (11m) ~ R15 (15m)
	R16 (16m) ~ R20 (20m)

* Refer to P.144 for more information regarding the maintenance cables.

Options

Name	Option Code	Reference Page
Brake	B	See P.105
Cable exit direction (Top)	CJT	See P.105
Cable exit direction (Right)	CJR	See P.105
Cable exit direction (Left)	CJL	See P.105
Cable exit direction (Bottom)	CJB	See P.105
High-precision specification (*1)	HPR	See P.108
Non-motor end specification	NM	See P.110
Slider roller specification	SR	See P.111
Double slider (*2)	W	See P.112

Actuator Specifications

Item	Description
Drive system	Ball screw ø10mm, rolled C10
Positioning repeatability (*1)	±0.01mm [±0.005mm]
Lost motion	0.1mm or less
Base	Material: Aluminum with white alumite treatment
Static allowable moment	Ma: 48.5N·m, Mb: 69.3N·m, Mc: 103N·m
Dynamic allowable moment (*2)	Ma: 11.6N·m, Mb: 16.6N·m, Mc: 24.6N·m
Ambient operating temp. & humidity	0~40°C, 85% RH or less (Non-condensing)

(*1) Values in [] are for high-precision (for lead 3/6/12) specification.
(*2) Assumes a standard rated life of 5000km. The service life will vary depending on operation and installation conditions.

• Reference for overhang load length: Ma: 220mm or less, Mb, Mc: 220mm or less

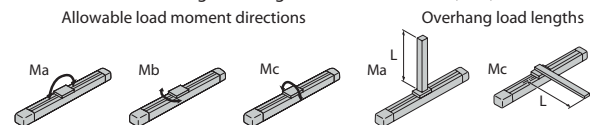

Please refer to the RoboCylinder General Catalog for more information regarding the directions of the allowable moment and overhang load length.

(*1) Positioning repeatability is ±5µm for high-precision specification (HPR).

High-precision specification option cannot be selected for lead 20 and cannot be selected together with the double slider option.

(*2) This option is not available with some combination of the leads and mounting positions. Please refer to P.131 for more information.

Dimensions

CAD drawings can be downloaded from our website.

www.robocylinder.de



*1 When the slider is returning to its home position, please be careful of interference from surrounding objects, as it will travel until it reaches the M.E.
M.E: Mechanical end S.E: Stroke end

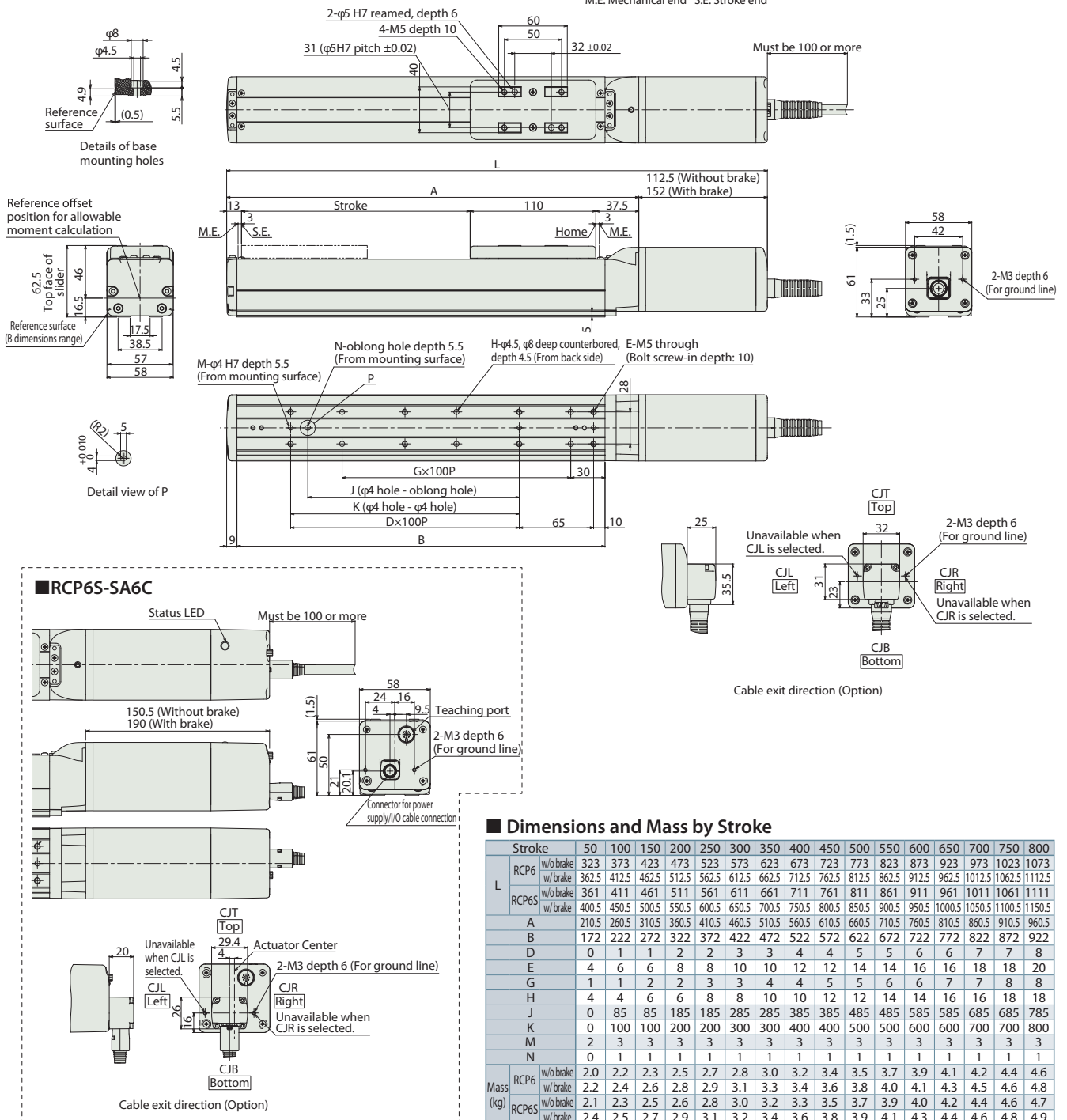

Applicable Controllers

The RCP6 series actuators can be operated by the controllers indicated below. Please select the type depending on your intended use. * Please refer to P.147 for more information about the built-in controller of RCP6S series.

Name	External view	Max. number of controlled axes	Input power	Control method				Maximum number of positioning points	Reference page
				Positioner	Pulse train	Program	Network *Option		
PCON-CB/CGB		1	DC24V	● *Option	● *Option	-	 	512 (768 for network spec.)	Please see P.132
MCON-C/CG		4		This model is network-compatible only.					
MSEL-PC/PG		4	Single-phase 100~230VAC	-	-	●	Note: The type of compatible networks will vary depending on the controller. Please refer to reference page for more information.	30000	Please see the MSEL-PC/PG catalog or manual.

* Please select "high-output specification" as an option for the MCON. With the MCON, operation is possible only when the high-output specification is selected.

RCP6(S)-SA7C



Model Specification Items	Series	Type	Encoder Type	Motor Type	Lead	Stroke	Applicable Controller/I/O Type	Cable Length	Options
	SA7C	WA	56P						
	RCP6: Separate Controller RCP6S: Built-in Controller	WA: Battery-less Absolute	56P: Pulse Motor 56□ Size	24: 24mm 16: 16mm 8: 8mm 4: 4mm	50: 50mm 800: 800mm (50mm increments)	[RCP6] P3: PCON MCON MSEL [RCP6S] SE: SIO Type	N: None P: 1m S: 3m M: 5m X□□: Specified Length R□□: Robot Cable	Please refer to the options table below.	

* RCP6 does not include a controller. RCP6S includes a built-in controller.
** Preview: Cleanroom type RCP6(S)CR-SA7C comes later.

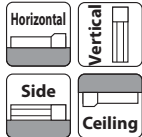

*Depending on the model, there may be some limitations to using the vertical, side, and ceiling mount positions. Please contact IAI for more information regarding mounting positions.



- POINT Selection Notes**
- (1) The maximum acceleration/deceleration is 1G for horizontal, and 0.5G for vertical use.
 - (2) The actuator specification displays the payload's maximum value, but it will vary depending on the acceleration and speed. Please refer to the "Selection Guidelines" (RCP6 Tables of Payload by Speed/Acceleration) on P.115 for more details.
 - (3) When performing push-motion operation, please confirm the push force of each model by checking the "Correlation diagram of push force and current limit" on P.113.
 - (4) Depending on the ambient operational temperature, duty control is necessary for the RCP6S (built-in controller type) with lead 4/8/16. Please refer to P.130 for more information.

Correlation Diagrams of Speed and Payload

High-output enabled (*) with PCON/MCON/MSEL connected.
RCP6(S)-SA7C Horizontal mount

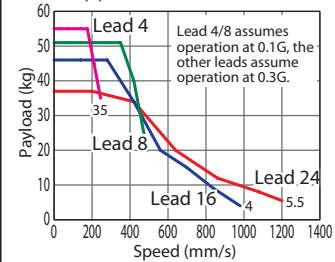

RCP6(S)-SA7C Vertical mount

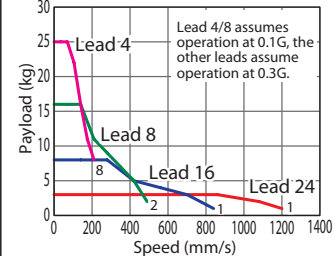

(*) For high output setting to OFF refer to the RCP6 manual.

Actuator Specifications (*)

(*) For values of disabled high output controller setting refer to the RCP6 manual.

Lead and Payload

Model Number	Lead (mm)	Connected Controller	Max. Payload		Stroke (mm)
			Horizontal (kg)	Vertical (kg)	
RCP6(S)-SA7C-WA-56P-24-①-②-③-④	24	High-output Enabled	37	3	50~800 (The increment of stroke is 50mm)
RCP6(S)-SA7C-WA-56P-16-①-②-③-④	16	High-output Enabled	46	8	
RCP6(S)-SA7C-WA-56P-8-①-②-③-④	8	High-output Enabled	51	16	
RCP6(S)-SA7C-WA-56P-4-①-②-③-④	4	High-output Enabled	55	25	

Legend: ① Stroke ② Applicable controller/I/O type ③ Cable length ④ Options

Stroke and Max. Speed

(Unit: mm/s)

Lead (mm)	Connected Controller	50~500 (Every 50mm)	550 (mm)	600 (mm)	650 (mm)	700 (mm)	750 (mm)	800 (mm)
24	High-output Enabled	1200		1095	965	850	760	
16	High-output Enabled	980 <840>	965 <840>	830	720	635	560	500
8	High-output Enabled	490	475	410	355	315	275	245
4	High-output Enabled	245 <210>	235 <210>	205	175	155	135	120

Values in brackets < > are for vertical use.

Cable Length

Cable Type	Cable Code
Standard	P (1m)
	S (3m)
	M (5m)
Specified Length	X06 (6m) ~ X10 (10m)
	X11 (11m) ~ X15 (15m)
	X16 (16m) ~ X20 (20m)
	R01 (1m) ~ R03 (3m)
Robot Cable	R04 (4m) ~ R05 (5m)
	R06 (6m) ~ R10 (10m)
	R11 (11m) ~ R15 (15m)
	R16 (16m) ~ R20 (20m)

* Refer to P.144 for more information regarding the maintenance cables.

Options

Name	Option Code	Reference Page
Brake	B	See P.105
Cable exit direction (Top)	CJT	See P.105
Cable exit direction (Right)	CJR	See P.105
Cable exit direction (Left)	CJL	See P.105
Cable exit direction (Bottom)	CJB	See P.105
High-precision specification (*1)	HPR	See P.108
Non-motor end specification	NM	See P.110
Slider roller specification	SR	See P.111
Double slider (*2)	W	See P.112

Actuator Specifications

Item	Description
Drive system	Ball screw ø12mm, rolled C10
Positioning repeatability (*1)	±0.01mm [±0.005mm]
Lost motion	0.1mm or less
Base	Material: Aluminum with white alumite treatment
Static allowable moment	Ma: 115N·m, Mb: 115N·m, Mc: 229N·m
Dynamic allowable moment (*2)	Ma: 44.7N·m, Mb: 44.7N·m, Mc: 89.1N·m
Ambient operating temp. & humidity	0~40°C, 85% RH or less (Non-condensing)

(*1) Values in [] are for high-precision (for lead 4/8) specification.
(*2) Assumes a standard rated life of 5000km. The service life will vary depending on operation and installation conditions.

• Reference for overhang load length: Ma: 300mm or less, Mb, Mc: 300mm or less

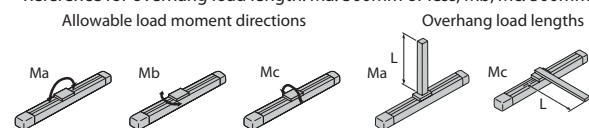

Please refer to the RoboCylinder General Catalog for more information regarding the directions of the allowable moment and overhang load length.

(*1) Positioning repeatability is ±5µm for high-precision specification (HPR). High-precision specification option cannot be selected for lead 16 or 24 and cannot be selected together with the double slider option.

(*2) This option is not available with some combination of the leads and mounting positions. Please refer to P.131 for more information.

Dimensions

CAD drawings can be downloaded from our website.

www.robocylinder.de



*1 When the slider is returning to its home position, please be careful of interference from surrounding objects, as it will travel until it reaches the M.E.
M.E: Mechanical end S.E: Stroke end

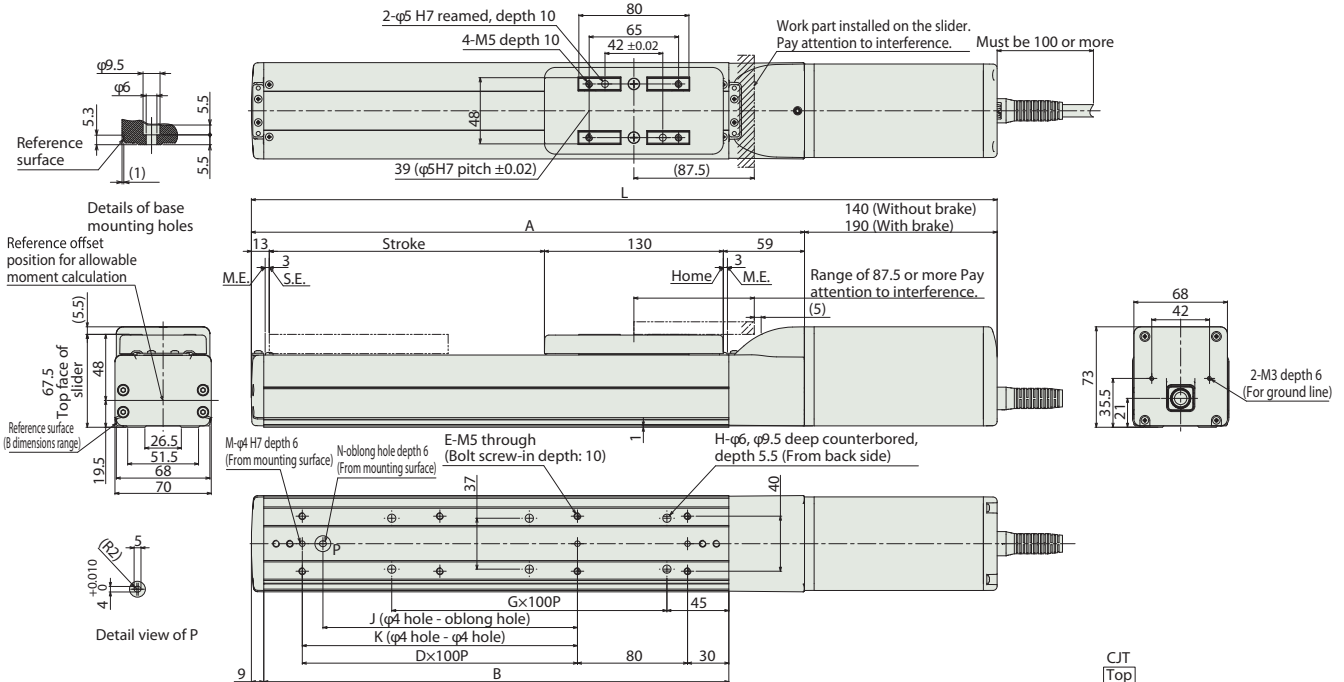

RCP6S-SA7C

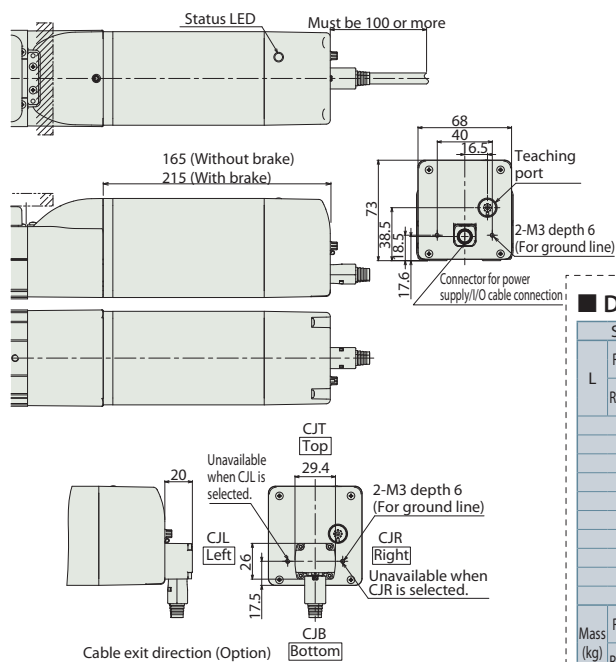

Dimensions and Mass by Stroke

	Stroke	50	100	150	200	250	300	350	400	450	500	550	600	650	700	750	800
L	RCP6 w/o brake	392	442	492	542	592	642	692	742	792	842	892	942	992	1042	1092	1142
	RCP6S w/o brake	417	467	517	567	617	667	717	767	817	867	917	967	1017	1067	1117	1167
A	RCP6 w/ brake	442	492	542	592	642	692	742	792	842	892	942	992	1042	1092	1142	1192
	RCP6S w/ brake	467	517	567	617	667	717	767	817	867	917	967	1017	1067	1117	1167	1217
B		252	302	352	402	452	502	552	602	652	702	752	802	852	902	952	1002
D		188	238	288	338	388	438	488	538	588	638	688	738	788	838	888	938
E		0	1	1	2	2	3	3	4	4	5	5	6	6	7	7	8
G		4	6	6	8	8	10	10	12	12	14	14	16	16	18	18	20
H		1	1	2	2	3	3	4	4	5	5	6	6	7	7	8	8
J		4	4	6	6	8	8	10	10	12	12	14	14	16	16	18	18
K		0	85	85	185	185	285	285	385	385	485	485	585	585	685	685	785
M		0	0	100	200	200	300	300	400	400	500	500	600	600	700	700	800
N		2	2	3	3	3	3	3	3	3	3	3	3	3	3	3	3
Mass (kg)	RCP6 w/o brake	0	1	1	1	1	1	1	1	1	1	1	1	1	1	1	1
	RCP6S w/o brake	3.6	3.8	4.0	4.3	4.5	4.7	4.9	5.2	5.4	5.6	5.9	6.1	6.3	6.5	6.8	7.0
Mass (kg)	RCP6 w/ brake	4.0	4.2	4.5	4.7	4.9	5.1	5.4	5.6	5.8	6.1	6.3	6.5	6.7	7.0	7.2	7.4
	RCP6S w/ brake	3.8	4.0	4.2	4.4	4.7	4.9	5.1	5.3	5.6	5.8	6.0	6.3	6.5	6.7	6.9	7.2

Applicable Controllers

The RCP6 series actuators can be operated by the controllers indicated below. Please select the type depending on your intended use. * Please refer to P.147 for more information about the built-in controller of RCP6S series.

Name	External view	Max. number of controlled axes	Input power	Control method				Maximum number of positioning points	Reference page
				Positioner	Pulse train	Program	Network *Option		
PCON-CB/CGB		1	DC24V	● *Option	● *Option	-		512 (768 for network spec.)	Please see P.132
MCON-C/CG		4		This model is network-compatible only.					256
MSEL-PC/PG		4	Single-phase 100~230VAC	-	-	●	Note: The type of compatible networks will vary depending on the controller. Please refer to reference page for more information.	30000	Please see the MSEL-PC/PG catalog or manual.

* Please select "high-output specification" as an option for the MCON. With the MCON, operation is possible only when the high-output specification is selected.

RCP6(S)-SA8C

±10µm Standard
±5µm Optional
Simple Dust-proof
Battery-less Absolute
Motor Unit Coupled
Straight Motor
Body Width 85mm
24v Pulse Motor

Model Specification Items	Series	Type	Encoder Type	Motor Type	Lead	Stroke	Applicable Controller/I/O Type	Cable Length	Options
	RCP6: Separate Controller RCP6S: Built-in Controller	SA8C	WA: Battery-less Absolute	56SP: High-thrust Pulse Motor 56□ Size	30: 30mm 20: 20mm 10: 10mm 5: 5mm	50: 50mm 1100: 1100mm (50mm increments)	[RCP6] P4: PCON-CFB/CGFB [RCP6S] SE: SIO Type	N: None P: 1m S: 3m M: 5m	Please refer to the options table below.

* RCP6 does not include a controller. RCP6S includes a built-in controller.
** Preview: Cleanroom type RCP6(S)CR-SA8C comes later.

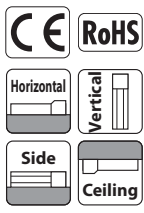

*Depending on the model, there may be some limitations to using the vertical, side, and ceiling mount positions. Please contact IAI for more information regarding mounting positions



- POINT Selection Notes**
- (1) The maximum acceleration/deceleration is 1G for horizontal, and 0.5G for vertical use.
 - (2) The actuator specification displays the payload's maximum value, but it will vary depending on the acceleration and speed. Please refer to the "Selection Guidelines" (RCP6 Tables of Payload by Speed/Acceleration) on P.115 for more details.
 - (3) When performing push-motion operation, please confirm the push force of each model by checking the "Correlation diagram of push force and current limit" on P.113.

Correlation Diagrams of Speed and Payload

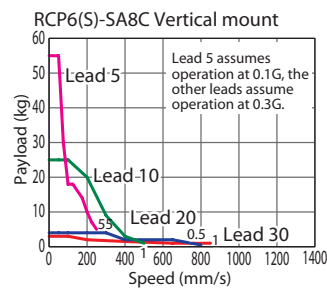
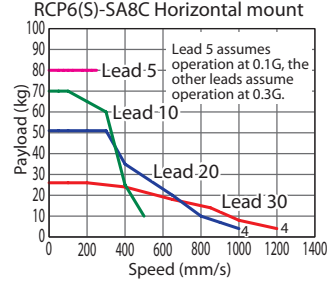

Actuator Specifications

Lead and Payload

Model Number	Lead (mm)	Max. Payload		Stroke (mm)
		Horizontal (kg)	Vertical (kg)	
RCP6(S)-SA8C-WA-56SP-30-①-②-③-④	30	28	3	50~1100 (The increment of stroke is 50mm)
RCP6(S)-SA8C-WA-56SP-20-①-②-③-④	20	60	4	
RCP6(S)-SA8C-WA-56SP-10-①-②-③-④	10	70	25	
RCP6(S)-SA8C-WA-56SP-5-①-②-③-④	5	80	55	

Legend: ① Stroke ② Applicable controller/I/O type ③ Cable length ④ Options

Stroke and Max. Speed

Lead (mm)	Max. Speed (Unit: mm/s)									
	50~650 (Every 50mm)	700 (mm)	750 (mm)	800 (mm)	850 (mm)	900 (mm)	950 (mm)	1000 (mm)	1050 (mm)	1100 (mm)
30	1200 <850>		1155 <850>	1040 <850>	940 <850>	855 <850>	780	715	660	
20	1000 <800>	950 <800>	860 <800>	770	695	630	570	520	480	440
10	500	480	430	385	345	310	285	260	235	220
5	250	240	215	190	175	155	140	130	120	110

Values in brackets < > are for vertical use.

Cable Length

Cable Type	Cable Code
Standard	P (1m)
	S (3m)
	M (5m)
Specified Length	X06 (6m) ~ X10 (10m)
	X11 (11m) ~ X15 (15m)
	X16 (16m) ~ X20 (20m)
	R01 (1m) ~ R03 (3m)
Robot Cable	R04 (4m) ~ R05 (5m)
	R06 (6m) ~ R10 (10m)
	R11 (11m) ~ R15 (15m)
	R16 (16m) ~ R20 (20m)

* Refer to P.144 for more information regarding the maintenance cables.

Options

Name	Option Code	Reference Page
Brake	B	See P.105
Cable exit direction (Top)	CJT	See P.105
Cable exit direction (Right)	CJR	See P.105
Cable exit direction (Left)	CJL	See P.105
Cable exit direction (Bottom)	CJB	See P.105
High-precision specification (*1)	HPR	See P.108
Non-motor end specification	NM	See P.110
Slider roller specification	SR	See P.111
Double slider (*2)	W	See P.112

Actuator Specifications

Item	Description
Drive system	Ball screw ø16mm, rolled C10
Positioning repeatability (*1)	±0.01mm [±0.005mm]
Lost motion	0.1mm or less
Base	Material: Aluminum with white alumite treatment
Static allowable moment	Ma: 219N·m, Mb: 219N·m, Mc: 414N·m
Dynamic allowable moment (*2)	Ma: 77.0N·m, Mb: 77.0N·m, Mc: 146N·m
Ambient operating temp. & humidity	0~40°C, 85% RH or less (Non-condensing)

(*1) Values in [] are for high-precision (for lead 5/10) specification.
(*2) Assumes a standard rated life of 5000km. The service life will vary depending on operation and installation conditions.

• Reference for overhang load length: Ma: 400mm or less, Mb, Mc: 400mm or less

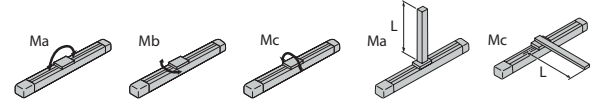

Please refer to the RoboCylinder General Catalog for more information regarding the directions of the allowable moment and overhang load length.

(*1) Positioning repeatability is ±5µm for high-precision specification (HPR). High-precision specification option cannot be selected for lead 20 or 30 and cannot be selected together with the double slider option.
(*2) This option is not available with some combination of the leads and mounting positions. Please refer to P.131 for more information.

RCP6(S)-SA4R



±10µm
Standard



Simple
Dust-proof



Battery-less
Absolute



Motor
Unit
Coupled



Side-mounted
Motor



Body Width
40mm



24V
Pulse
Motor

Model Specification Items	Series	Type	Encoder Type	Motor Type	Lead	Stroke	Applicable Controller/I/O Type	Cable Length	Options
	RCP6	SA4R	WA	35P	16: 16mm 10: 10mm 5: 5mm 2.5: 2.5mm	50: 50mm 500: 500mm (50mm increments)	[RCP6] P3: PCON MCON MSEL [RCP6S] SE: SIO Type	N : None P : 1m S : 3m M : 5m X□ : Specified Length R□ : Robot Cable	Please refer to the options table below. *Please make sure to specify either ML or MR when ordering the side-mounted motor type.

* RCP6 does not include a controller. RCP6S includes a built-in controller. * Body width does not include the width of the side-mounted motor.

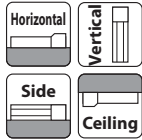

*Depending on the model, there may be some limitations to using the vertical, side, and ceiling mount positions. Please contact IAI for more information regarding mounting positions.



The figure above is the motor side-mounted to the left (ML).

POINT Selection Notes

- (1) The maximum acceleration/deceleration is 1G for horizontal, and 0.5G for vertical use.
- (2) The actuator specification displays the payload's maximum value, but it will vary depending on the acceleration and speed. Please refer to the "Selection Guidelines" (RCP6 Tables of Payload by Speed/Acceleration) on P.115 for more details.
- (3) When performing push-motion operation, please confirm the push force of each model by checking the "Correlation diagram of push force and current limit" on P.113.

Correlation Diagrams of Speed and Payload

High-output enabled (*) with PCON/MCON/MSEL connected.

RCP6(S)-SA4R Horizontal mount

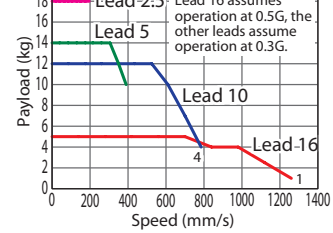

RCP6(S)-SA4R Vertical mount

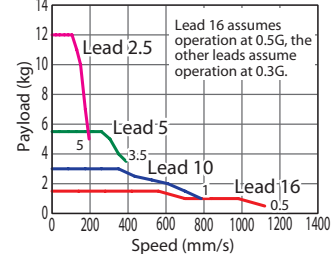

(*) For high output setting to OFF refer to the RCP6 manual.

Actuator Specifications (*)

(*) For values of disabled high output controller setting refer to the RCP6 manual.

Lead and Payload

Model Number	Lead (mm)	Connected Controller	Max. Payload		Stroke (mm)
			Horizontal (kg)	Vertical (kg)	
RCP6(S)-SA4R-WA-35P-16-①-②-③-④	16	High-output Enabled	7	1.5	50~500 (The increment of stroke is 50mm)
RCP6(S)-SA4R-WA-35P-10-①-②-③-④	10	High-output Enabled	12	3	
RCP6(S)-SA4R-WA-35P-5-①-②-③-④	5	High-output Enabled	14	5.5	
RCP6(S)-SA4R-WA-35P-2.5-①-②-③-④	2.5	High-output Enabled	18	12	

Legend: ① Stroke ② Applicable controller/I/O type ③ Cable length ④ Options

Stroke and Max. Speed

(Unit: mm/s)

Lead (mm)	Connected Controller	50~400	450	500
		(Every 50mm)	(mm)	(mm)
16	High-output Enabled	1260 <1120>	1060	875
10	High-output Enabled	785	675	555
5	High-output Enabled	390	330	275
2.5	High-output Enabled	195	165	135

Values in brackets < > are for vertical use.

Cable Length

Cable Type	Cable Code
Standard	P (1m)
	S (3m)
	M (5m)
Specified Length	X06 (6m) ~ X10 (10m)
	X11 (11m) ~ X15 (15m)
	X16 (16m) ~ X20 (20m)
	R01 (1m) ~ R03 (3m)
Robot Cable	R04 (4m) ~ R05 (5m)
	R06 (6m) ~ R10 (10m)
	R11 (11m) ~ R15 (15m)
	R16 (16m) ~ R20 (20m)
	R16 (16m) ~ R20 (20m)

* Refer to P.144 for more information regarding the maintenance cables.

Options

Name	Option Code	Reference Page
Brake	B	See P.105
Cable exit direction (Outside)	CJO	See P.105
Motor side-mounted to the left	ML	See P.109
Motor side-mounted to the right	MR	See P.109
Non-motor end specification	NM	See P.110
Slider roller specification	SR	See P.111
Double slider (*1)	W	See P.112

(*1) This option is not available with some combination of the leads and mounting positions. Please refer to P.131 for more information.

Actuator Specifications

Item	Description
Drive system	Ball screw ø8mm, rolled C10
Positioning repeatability	±0.01mm
Lost motion	0.1mm or less
Base	Material: Aluminum with white alumite treatment
Static allowable moment	Ma: 13.0N·m, Mb: 18.6N·m, Mc: 25.3N·m
Dynamic allowable moment (*1)	Ma: 5.0N·m, Mb: 7.1N·m, Mc: 9.7N·m
Ambient operating temp. & humidity	0~40°C, 85% RH or less (Non-condensing)

(*1) Assumes a standard rated life of 5000km. The service life will vary depending on operation and installation conditions.

• Reference for overhang load length: Ma: 150mm or less, Mb, Mc: 150mm or less

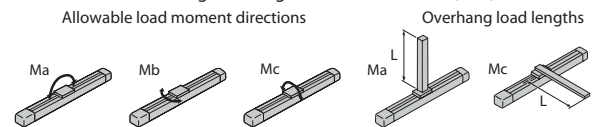

Please refer to the RoboCylinder General Catalog for more information regarding the directions of the allowable moment and overhang load length.

Dimensions

CAD drawings can be downloaded from our website.
www.robocylinder.de

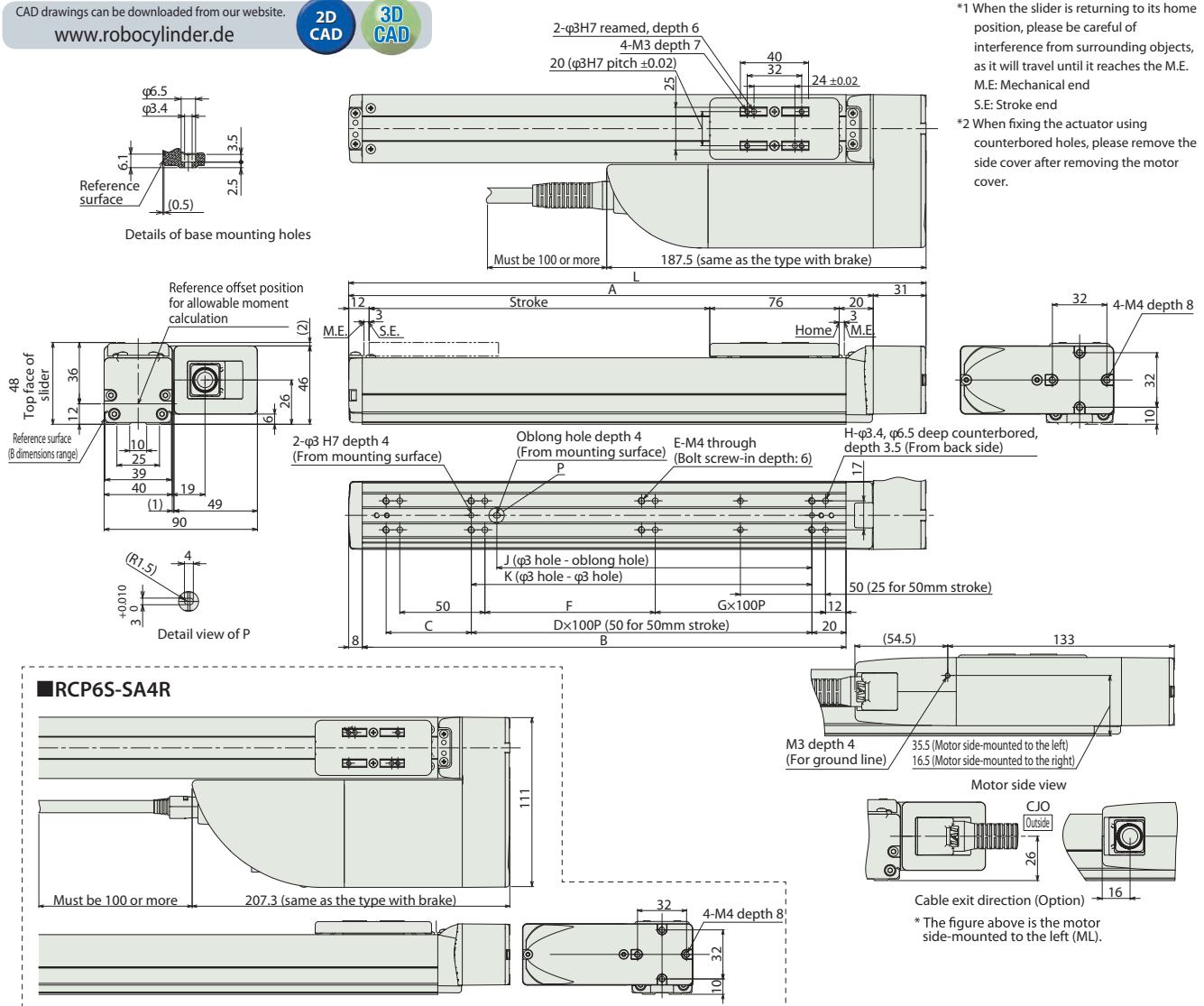

*1 When the slider is returning to its home position, please be careful of interference from surrounding objects, as it will travel until it reaches the M.E.
M.E: Mechanical end
S.E: Stroke end
*2 When fixing the actuator using counterbored holes, please remove the side cover after removing the motor cover.

RCP6S-SA4R

Dimensions and Mass by Stroke

Stroke	50	100	150	200	250	300	350	400	450	500	
L	189	239	289	339	389	439	489	539	589	639	
A	158	208	258	308	358	408	458	508	558	608	
B	134	184	234	284	334	384	434	484	534	584	
C	50	50	100	50	100	50	100	50	100	50	
D	-	1	1	2	2	3	3	4	4	5	
E	6	6	6	8	8	10	10	12	12	14	
F	50	100	50	100	50	100	50	100	50	100	
G	0	0	1	1	2	2	3	3	4	4	
H	8	8	10	10	12	12	14	14	16	16	
J	35	85	85	185	185	285	285	385	385	485	
K	50	100	100	200	200	300	300	400	400	500	
Mass (kg)	RCP6	w/o brake	1.3	1.4	1.5	1.6	1.7	1.8	1.9	2.0	2.1
		w/ brake	1.4	1.5	1.5	1.6	1.7	1.8	1.9	2.0	2.1
	RCP6S	w/o brake	1.4	1.5	1.6	1.7	1.8	1.9	2.0	2.1	2.2
		w/ brake	1.5	1.6	1.7	1.8	1.8	1.9	2.0	2.1	2.2

Applicable Controllers

The RCP6 series actuators can be operated by the controllers indicated below. Please select the type depending on your intended use. * Please refer to P.147 for more information about the built-in controller of RCP6S series.

Name	External view	Max. number of controlled axes	Input power	Control method				Maximum number of positioning points	Reference page
				Positioner	Pulse train	Program	Network *Option		
PCON-CB/CGB		1	DC24V	● *Option	● *Option	-	 	512 (768 for network spec.)	Please see P.132
MCON-C/CG		4		This model is network-compatible only.				 	256
MSEL-PC/PG		4	Single-phase 100~230VAC	-	-	●	Note: The type of compatible networks will vary depending on the controller. Please refer to reference page for more information.	30000	Please see the MSEL-PC/PG catalog or manual.

* Please select "high-output specification" as an option for the MCON. With the MCON, operation is possible only when the high-output specification is selected.

RCP6(S)-SA6R

±10μm Standard
Simple Dust-proof
Battery-less Absolute
Motor Unit Coupled
Side-mounted Motor
Body Width 58* mm
24v Pulse Motor

Model Specification Items	Series	Type	Encoder Type	Motor Type	Lead	Stroke	Applicable Controller/I/O Type	Cable Length	Options
	SA6R	WA	42P						
	RCP6: Separate Controller RCP6S: Built-in Controller		WA: Battery-less Absolute	42P: Pulse Motor 42□ Size	20: 20mm 12: 12mm 6: 6mm 3: 3mm	50: 50mm 800: 800mm (50mm increments)	[RCP6] P3: PCON MCON MSEL [RCP6S] SE: SIO Type	N : None P : 1m S : 3m M : 5m X□ : Specified Length R□ : Robot Cable	Please refer to the options table below. * Please make sure to specify either ML or MR when ordering the side-mounted motor type.

* RCP6 does not include a controller. RCP6S includes a built-in controller.

* Body width does not include the width of the side-mounted motor.

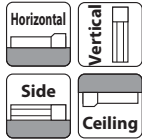

*Depending on the model, there may be some limitations to using the vertical, side, and ceiling mount positions. Please contact IAI for more information regarding mounting positions.



The figure above is the motor side-mounted to the left (ML).

- POINT Selection Notes**
- (1) The maximum acceleration/deceleration is 1G for horizontal, and 0.5G for vertical use.
 - (2) The actuator specification displays the payload's maximum value, but it will vary depending on the acceleration and speed. Please refer to the "Selection Guidelines" (RCP6 Tables of Payload by Speed/Acceleration) on P.115 for more details.
 - (3) When performing push-motion operation, please confirm the push force of each model by checking the "Correlation diagram of push force and current limit" on P.113.
 - (4) Depending on the ambient operational temperature, duty control is necessary for the RCP6S (built-in controller type) with lead 3/6. Please refer to P.130 for more information.

Correlation Diagrams of Speed and Payload

High-output enabled (*) with PCON/MCON/MSEL connected.
RCP6(S)-SA6R Horizontal mount

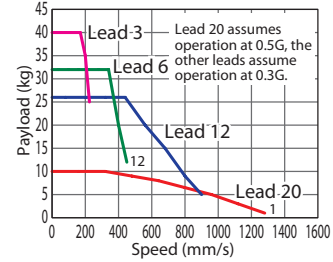

RCP6(S)-SA6R Vertical mount

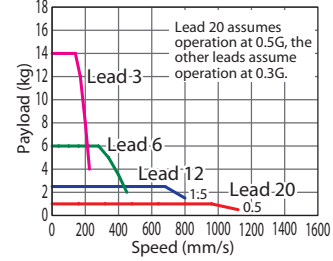

(*) For high output setting to OFF, refer to the RCP6 manual.

Actuator Specifications (*)

(*) For values of disabled high output controller setting refer to the RCP6 manual.

Lead and Payload

Model Number	Lead (mm)	Connected Controller	Max. Payload		Stroke (mm)
			Horizontal (kg)	Vertical (kg)	
RCP6(S)-SA6R-WA-42P-20-①-②-③-④	20	High-output Enabled	15	1	50~800 (The increment of stroke is 50mm)
RCP6(S)-SA6R-WA-42P-12-①-②-③-④	12	High-output Enabled	28	2.5	
RCP6(S)-SA6R-WA-42P-6-①-②-③-④	6	High-output Enabled	32	6	
RCP6(S)-SA6R-WA-42P-3-①-②-③-④	3	High-output Enabled	40	14	

Legend: ① Stroke ② Applicable controller/I/O type ③ Cable length ④ Options

Stroke and Max. Speed

(Unit: mm/s)

Lead (mm)	Connected Controller	Max. Speed								
		50~400 (Every 50mm)	450 (mm)	500 (mm)	550 (mm)	600 (mm)	650 (mm)	700 (mm)	750 (mm)	800 (mm)
20	High-output Enabled	1280 <1120>		1130 <1120>	970	840	735	650	575	
12	High-output Enabled	900 <800>	885 <800>	735	620	535	460	405	355	315
6	High-output Enabled	450	435	365	305	265	230	200	175	155
3	High-output Enabled	225	215	180	150	130	115	100	85	75

Values in brackets < > are for vertical use.

Cable Length

Cable Type	Cable Code
Standard	P (1m)
	S (3m)
	M (5m)
Specified Length	X06 (6m) ~ X10 (10m)
	X11 (11m) ~ X15 (15m)
	X16 (16m) ~ X20 (20m)
	R01 (1m) ~ R03 (3m)
Robot Cable	R04 (4m) ~ R05 (5m)
	R06 (6m) ~ R10 (10m)
	R11 (11m) ~ R15 (15m)
	R16 (16m) ~ R20 (20m)
	R16 (16m) ~ R20 (20m)

* Refer to P.144 for more information regarding the maintenance cables.

Options

Name	Option Code	Reference Page
Brake	B	See P.105
Cable exit direction (Outside)	CJO	See P.105
Motor side-mounted to the left	ML	See P.109
Motor side-mounted to the right	MR	See P.109
Non-motor end specification	NM	See P.110
Slider roller specification	SR	See P.111
Double slider (*1)	W	See P.112

(*1) This option is not available with some combination of the leads and mounting positions. Please refer to P.131 for more information.

Actuator Specifications

Item	Description
Drive system	Ball screw ø10mm, rolled C10
Positioning repeatability	±0.01mm
Lost motion	0.1mm or less
Base	Material: Aluminum with white alumite treatment
Static allowable moment	Ma: 48.5N·m, Mb: 69.3N·m, Mc: 103N·m
Dynamic allowable moment (*1)	Ma: 11.6N·m, Mb: 16.6N·m, Mc: 24.6N·m
Ambient operating temp. & humidity	0~40°C, 85% RH or less (Non-condensing)

(*1) Assumes a standard rated life of 5000km. The service life will vary depending on operation and installation conditions.

- Reference for overhang load length: Ma: 220mm or less, Mb, Mc: 220mm or less

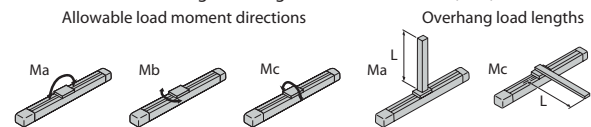

Please refer to the RoboCylinder General Catalog for more information regarding the directions of the allowable moment and overhang load length.

RCP6(S)-SA7R

±10μm Standard
Simple Dust-proof
Battery-less Absolute
Motor Unit Coupled
Side-mounted Motor
Body Width 70* mm
24v Pulse Motor

Model Specification Items	Series	Type	Encoder Type	Motor Type	Lead	Stroke	Applicable Controller/I/O Type	Cable Length	Options
	SA7R	WA	56P						
	RCP6: Separate Controller RCP6S: Built-in Controller		WA: Battery-less Absolute	56P: Pulse Motor 56□ Size	24: 24mm 16: 16mm 8: 8mm 4: 4mm	50: 50mm 800: 800mm (50mm increments)	[RCP6] P3: PCON MCON MSEL [RCP6S] SE: SIO Type	N : None P : 1m S : 3m M : 5m X□□ : Specified Length R□□ : Robot Cable	Please refer to the options table below. * Please make sure to specify either ML or MR when ordering the side-mounted motor type.

* RCP6 does not include a controller. RCP6S includes a built-in controller.

* Body width does not include the width of the side-mounted motor.

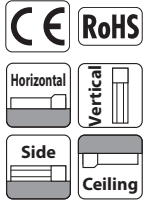

*Depending on the model, there may be some limitations to using the vertical, side, and ceiling mount positions. Please contact IAI for more information regarding mounting positions.



The figure above is the motor side-mounted to the left (ML).

- POINT Selection Notes**
- The maximum acceleration/deceleration is 1G for horizontal, and 0.5G for vertical use.
 - The actuator specification displays the payload's maximum value, but it will vary depending on the acceleration and speed. Please refer to the "Selection Guidelines" (RCP6 Tables of Payload by Speed/Acceleration) on P.115 for more details.
 - When performing push-motion operation, please confirm the push force of each model by checking the "Correlation diagram of push force and current limit" on P.113.
 - Depending on the ambient operational temperature, duty control is necessary for the RCP6S (built-in controller type) with lead 4/8/16. Please refer to P.130 for more information.

Correlation Diagrams of Speed and Payload

High-output enabled (*) with PCON/MCON/MSEL connected.
RCP6(S)-SA7R Horizontal mount

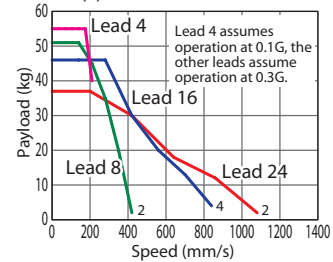

RCP6(S)-SA7R Vertical mount

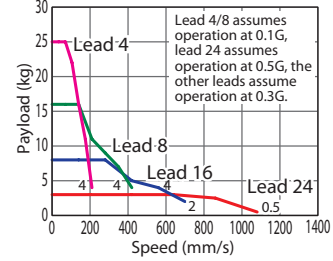

(*) For high output setting to OFF refer to the RCP6 manual.

Actuator Specifications (*)

(*) For values of disabled high output controller setting refer to the RCP6 manual.

Lead and Payload

Model Number	Lead (mm)	Connected Controller	Max. Payload		Stroke (mm)
			Horizontal (kg)	Vertical (kg)	
RCP6(S)-SA7R-WA-56P-24-①-②-③-④	24	High-output Enabled	37	3	50~800 (The increment of stroke is 50mm)
RCP6(S)-SA7R-WA-56P-16-①-②-③-④	16	High-output Enabled	46	8	
RCP6(S)-SA7R-WA-56P-8-①-②-③-④	8	High-output Enabled	51	16	
RCP6(S)-SA7R-WA-56P-4-①-②-③-④	4	High-output Enabled	55	25	

Legend: ① Stroke ② Applicable controller/I/O type ③ Cable length ④ Options

Stroke and Max. Speed

(Unit: mm/s)

Lead (mm)	Connected Controller	50~500 (Every 50mm)	550 (mm)	600 (mm)	650 (mm)	700 (mm)	750 (mm)	800 (mm)
24	High-output Enabled	1080			965	850	760	
16	High-output Enabled	840 <700>	830 <700>	720 <700>	635	560	500	
8	High-output Enabled	420	410	355	315	275	245	
4	High-output Enabled	210	205	175	155	135	120	

Values in brackets < > are for vertical use.

Cable Length

Cable Type	Cable Code
Standard	P (1m)
	S (3m)
	M (5m)
Specified Length	X06 (6m) ~ X10 (10m)
	X11 (11m) ~ X15 (15m)
	X16 (16m) ~ X20 (20m)
	X21 (21m) ~ X25 (25m)
Robot Cable	R01 (1m) ~ R03 (3m)
	R04 (4m) ~ R05 (5m)
	R06 (6m) ~ R10 (10m)
	R11 (11m) ~ R15 (15m)
	R16 (16m) ~ R20 (20m)
	R21 (21m) ~ R25 (25m)

* Refer to P.144 for more information regarding the maintenance cables.

Options

Name	Option Code	Reference Page
Brake	B	See P.105
Cable exit direction (Outside)	CJO	See P.105
Motor side-mounted to the left	ML	See P.109
Motor side-mounted to the right	MR	See P.109
Non-motor end specification	NM	See P.110
Slider spacer (*1)	SS	See P.111
Slider roller specification	SR	See P.111
Double slider (*2)	W	See P.112

Actuator Specifications

Item	Description
Drive system	Ball screw ø12mm, rolled C10
Positioning repeatability	±0.01mm
Lost motion	0.1mm or less
Base	Material: Aluminum with white alumite treatment
Static allowable moment	Ma: 115N·m, Mb: 115N·m, Mc: 229N·m
Dynamic allowable moment (*1)	Ma: 44.7N·m, Mb: 44.7N·m, Mc: 89.1N·m
Ambient operating temp. & humidity	0~40°C, 85% RH or less (Non-condensing)

(*1) Assumes a standard rated life of 5000km. The service life will vary depending on operation and installation conditions.

• Reference for overhang load length: Ma: 300mm or less, Mb, Mc: 300mm or less

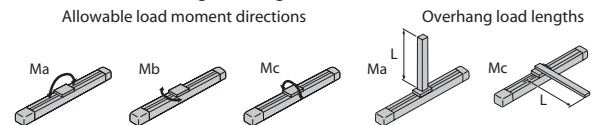

Please refer to the RoboCylinder General Catalog for more information regarding the directions of the allowable moment and overhang load length.

(*1) Slider spacer option cannot be selected together with the double slider option.

(*2) This option is not available with some combination of the leads and mounting positions. Please refer to P.131 for more information.

Dimensions

CAD drawings can be downloaded from our website.
www.robocylinder.de



*1 When the slider is returning to its home position, please be careful of interference from surrounding objects, as it will travel until it reaches the M.E.
M.E: Mechanical end
S.E: Stroke end
*2 When fixing the actuator using counterbored holes, please remove the side cover after removing the motor cover.

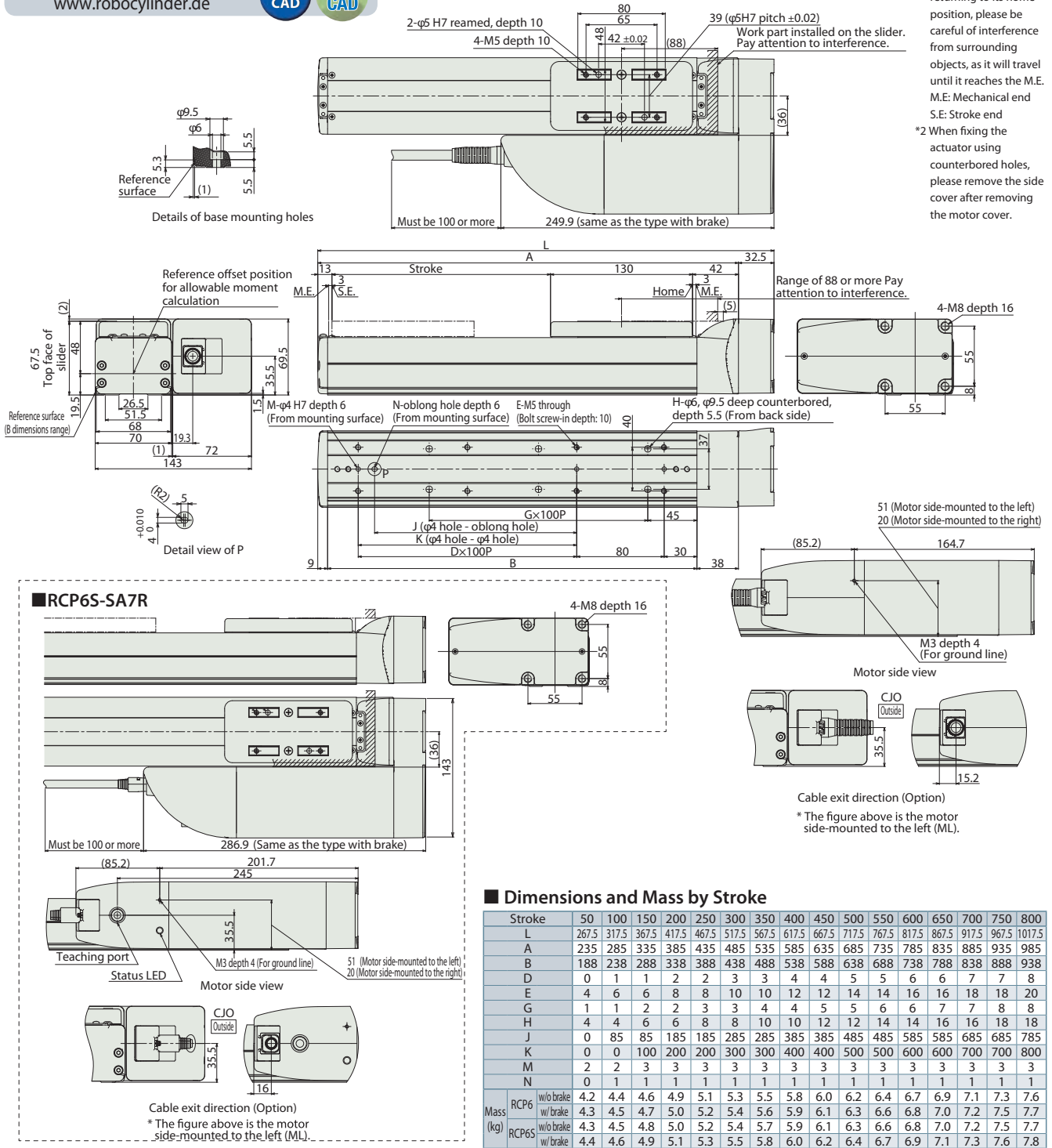

Applicable Controllers

The RCP6 series actuators can be operated by the controllers indicated below. Please select the type depending on your intended use. * Please refer to P.147 for more information about the built-in controller of RCP6S series.

Name	External view	Max. number of controlled axes	Input power	Control method				Maximum number of positioning points	Reference page
				Positioner	Pulse train	Program	Network *Option		
PCON-CB/CGB		1	DC24V	● *Option	● *Option	-		512 (768 for network spec.)	Please see P.132
MCON-C/CG		4		This model is network-compatible only.					256
MSEL-PC/PG		4	Single-phase 100~230VAC	-	-	●	Note: The type of compatible networks will vary depending on the controller. Please refer to reference page for more information.	30000	Please see the MSEL-PC/PG catalog or manual.

* Please select "high-output specification" as an option for the MCON. With the MCON, operation is possible only when the high-output specification is selected.

RCP6(S)-SA8R

±10μm Standard
Simple Dust-proof
Battery-less Absolute
Motor Unit Coupled
Side-mounted Motor
Body Width 85* mm
24v Pulse Motor

Model Specification Items	Series	Type	Encoder Type	Motor Type	Lead	Stroke	Applicable Controller/I/O Type	Cable Length	Options
	SA8R	WA	56SP						
	RCP6: Separate Controller RCP6S: Built-in Controller	WA: Battery-less Absolute	56SP: High-thrust Pulse Motor 56□ Size	30: 30mm 20: 20mm 10: 10mm 5: 5mm	50: 50mm 1100: 1100mm (50mm increments)	[RCP6] P4: PCON- CFB/CGFB [RCP6S] SE: SIO Type	N : None P : 1m S : 3m M : 5m X□ : Specified Length R□ : Robot Cable	Please refer to the options table below. * Please make sure to specify either ML or MR when ordering the side-mounted motor type.	

* RCP6 does not include a controller. RCP6S includes a built-in controller.

* Body width does not include the width of the side-mounted motor.

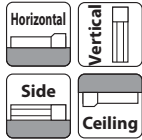

*Depending on the model, there may be some limitations to using the vertical, side, and ceiling mount positions. Please contact IAI for more information regarding mounting positions.



The figure above is the motor side-mounted to the left (ML).

POINT Selection Notes

- (1) The maximum acceleration/deceleration is 1G for horizontal, and 0.5G for vertical use.
- (2) The actuator specification displays the payload's maximum value, but it will vary depending on the acceleration and speed. Please refer to the "Selection Guidelines" (RCP6 Tables of Payload by Speed/Acceleration) on P.115 for more details.
- (3) When performing push-motion operation, please confirm the push force of each model by checking the "Correlation diagram of push force and current limit" on P.113.

Correlation Diagrams of Speed and Payload

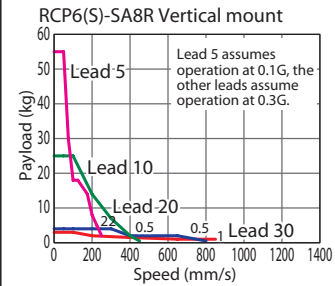
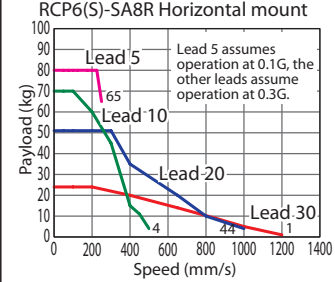

Actuator Specifications

Lead and Payload

Model Number	Lead (mm)	Max. Payload (kg)		Stroke (mm)
		Horizontal	Vertical	
RCP6(S)-SA8R-WA-56SP-30-①-②-③-④	30	26	3	50~1100 (The increment of stroke is 50mm)
RCP6(S)-SA8R-WA-56SP-20-①-②-③-④	20	55	4	
RCP6(S)-SA8R-WA-56SP-10-①-②-③-④	10	70	25	
RCP6(S)-SA8R-WA-56SP-5-①-②-③-④	5	80	55	

Legend: ① Stroke ② Applicable controller/I/O type ③ Cable length ④ Options

Stroke and Max. Speed

Lead (mm)	Max. Speed (mm/s)									
	50~650 (Every 50mm)	700 (mm)	750 (mm)	800 (mm)	850 (mm)	900 (mm)	950 (mm)	1000 (mm)	1050 (mm)	1100 (mm)
30	1200 <850>		1155 <850>	1040 <850>	940 <850>	855 <850>	780	715	660	
20	1000 <800>	950 <800>	860 <800>	770	695	630	570	520	480	440
10	500 <450>	480 <450>	430	385	345	310	285	260	235	220
5	250	240	215	190	175	155	145	130	120	110

Values in brackets < > are for vertical use.

Cable Length

Cable Type	Cable Code
Standard	P (1m)
	S (3m)
	M (5m)
Specified Length	X06 (6m) ~ X10 (10m)
	X11 (11m) ~ X15 (15m)
	X16 (16m) ~ X20 (20m)
	X21 (21m) ~ X25 (25m)
Robot Cable	R01 (1m) ~ R03 (3m)
	R04 (4m) ~ R05 (5m)
	R06 (6m) ~ R10 (10m)
	R11 (11m) ~ R15 (15m)
	R16 (16m) ~ R20 (20m)
	R21 (21m) ~ R25 (25m)

* Refer to P.144 for more information regarding the maintenance cables.

Options

Name	Option Code	Reference Page
Brake	B	See P.105
Cable exit direction (Outside)	CJO	See P.105
Motor side-mounted to the left	ML	See P.109
Motor side-mounted to the right	MR	See P.109
Non-motor end specification	NM	See P.110
Slider spacer (*1)	SS	See P.111
Slider roller specification	SR	See P.111
Double slider (*2)	W	See P.112

Actuator Specifications

Item	Description
Drive system	Ball screw ø16mm, rolled C10
Positioning repeatability	±0.01mm
Lost motion	0.1mm or less
Base	Material: Aluminum with white alumite treatment
Static allowable moment	Ma: 219N·m, Mb: 219N·m, Mc: 414N·m
Dynamic allowable moment (*1)	Ma: 77.0N·m, Mb: 77.0N·m, Mc: 146N·m
Ambient operating temp. & humidity	0~40°C, 85% RH or less (Non-condensing)

(*1) Assumes a standard rated life of 5000km. The service life will vary depending on operation and installation conditions.

* Reference for overhang load length: Ma: 400mm or less, Mb, Mc: 400mm or less

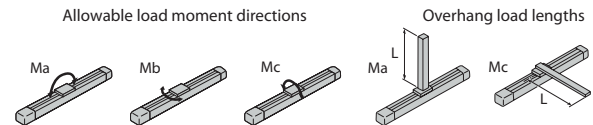

Please refer to the RoboCylinder General Catalog for more information regarding the directions of the allowable moment and overhang load length.

(*1) Slider spacer option cannot be selected together with the double slider option.

(*2) This option is not available with some combination of the leads and mounting positions. Please refer to P.131 for more information.

Dimensions

CAD drawings can be downloaded from our website.
www.robocylinder.de



*1 When the slider is returning to its home position, please be careful of interference from surrounding objects, as it will travel until it reaches the M.E. M.E: Mechanical end S.E: Stroke end
*2 When fixing the actuator using counterbored holes, please remove the side cover after removing the motor cover.

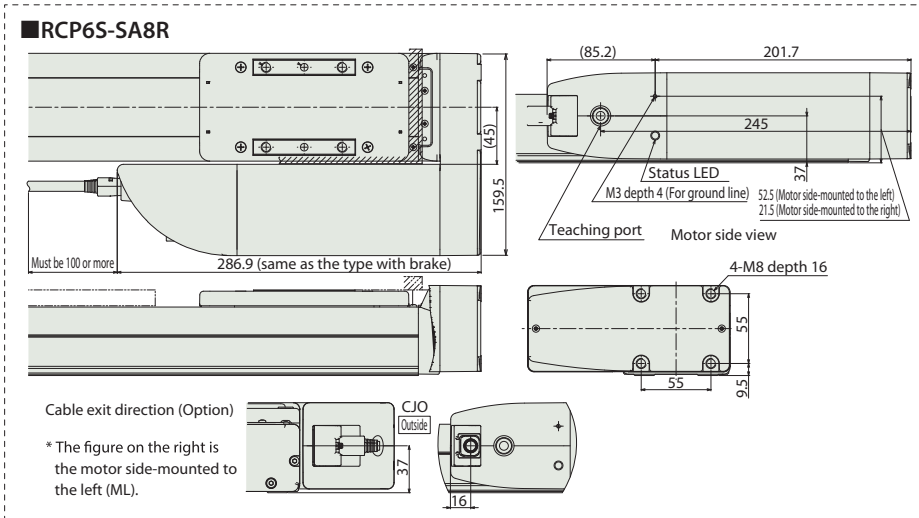
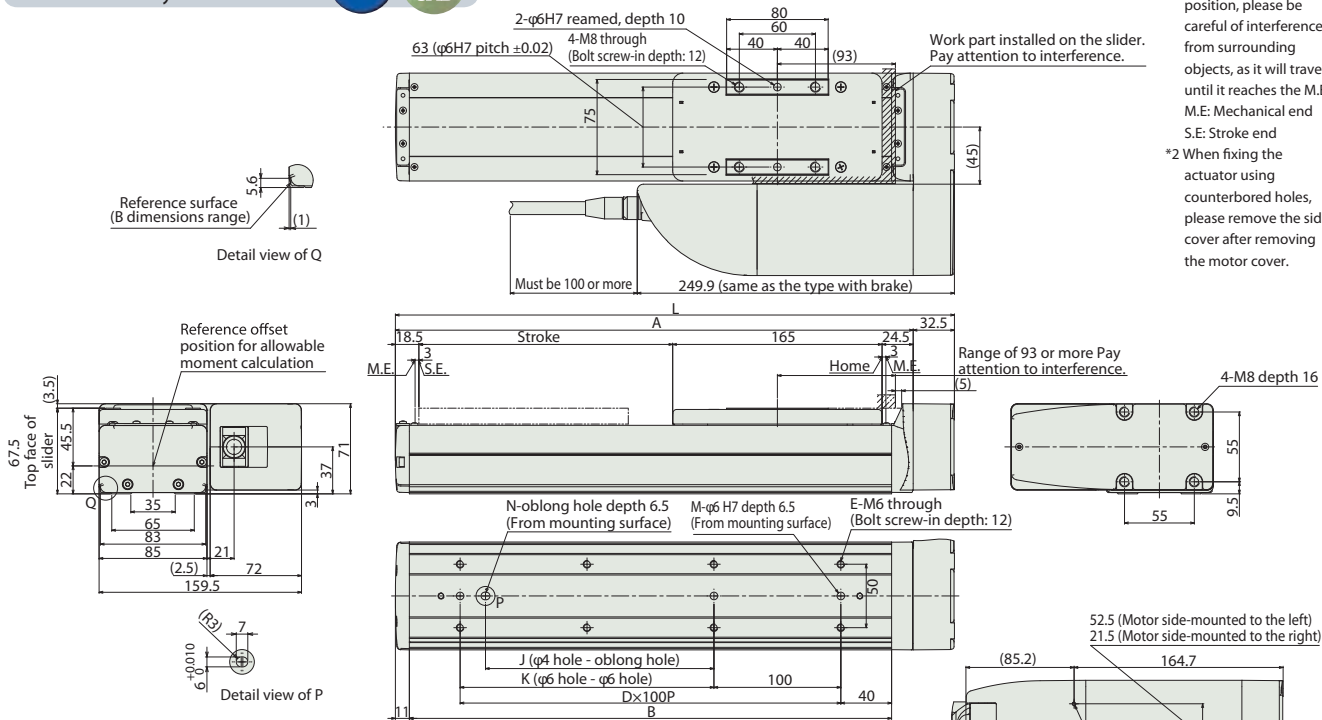

Dimensions and Mass by Stroke

Stroke	50	100	150	200	250	300	350	400	450	500	550	600	650	700	750	800	850	900	950	1000	1050	1100	
L	290.5	340.5	390.5	440.5	490.5	540.5	590.5	640.5	690.5	740.5	790.5	840.5	890.5	940.5	990.5	1040.5	1090.5	1140.5	1190.5	1240.5	1290.5	1340.5	
A	258	308	358	408	458	508	558	608	658	708	758	808	858	908	958	1008	1058	1108	1158	1208	1258	1308	
B	230	280	330	380	430	480	530	580	630	680	730	780	830	880	930	980	1030	1080	1130	1180	1230	1280	
D	1	2	2	3	3	4	4	5	5	6	6	7	7	8	8	9	9	10	10	11	11	12	
E	4	6	6	8	8	10	10	12	12	14	14	16	16	18	18	20	20	22	22	24	24	26	
J	0	0	80	180	180	280	280	380	380	480	480	580	580	680	680	780	780	880	880	980	980	1080	
K	0	100	100	200	200	300	300	400	400	500	500	600	600	700	700	800	800	900	900	1000	1000	1100	
M	2	3	3	3	3	3	3	3	3	3	3	3	3	3	3	3	3	3	3	3	3	3	
N	0	0	1	1	1	1	1	1	1	1	1	1	1	1	1	1	1	1	1	1	1	1	
Mass (kg)	RCP6	4.8	5.1	5.4	5.7	5.9	6.2	6.5	6.8	7.1	7.4	7.6	7.9	8.2	8.5	8.8	9.0	9.3	9.6	9.9	10.2	10.5	10.7
	w/o brake	5.0	5.3	5.5	5.8	6.1	6.4	6.7	6.9	7.2	7.5	7.8	8.1	8.4	8.6	8.9	9.2	9.5	9.8	10.1	10.3	10.6	10.9
	RCP6S	4.9	5.2	5.5	5.8	6.1	6.3	6.6	6.9	7.2	7.5	7.8	8.0	8.3	8.6	8.9	9.2	9.4	9.7	10.0	10.3	10.6	10.9
	w/ brake	5.1	5.4	5.7	5.9	6.2	6.5	6.8	7.1	7.3	7.6	7.9	8.2	8.5	8.8	9.0	9.3	9.6	9.9	10.2	10.5	10.7	11.0

Applicable Controllers

The RCP6 series actuators can be operated by the controllers indicated below. Please select the type depending on your intended use. * Please refer to P.147 for more information about the built-in controller of RCP6S series.

Name	External view	Max. number of controlled axes	Input power	Positioner	Pulse train	Program	Control method			Maximum number of positioning points	Reference page
							Network *Option				
PCON-CFB/CGFB		1	DC24V	● *Option	● *Option	-	DeviceNet	CompoNet	EtherNet/IP	512 (768 for network spec.)	Please see P.132

RCP6(S)-WSA10C



Model Specification Items	Series	Type	Encoder Type	Motor Type	Lead	Stroke	Applicable Controller/I/O Type	Cable Length	Options
	WSA10C	WA	35P						
	RCP6: Separate Controller RCP6S: Built-in Controller		WA: Battery-less Absolute	35P: Pulse Motor 35□ Size	16: 16mm 10: 10mm 5: 5mm 2.5: 2.5mm	50: 50mm 500: 500mm (50mm increments)	[RCP6] P3: PCON MCON MSEL [RCP6S] SE: SIO Type	N : None P : 1m S : 3m M : 5m X□ : Specified Length R□ : Robot Cable	Please refer to the options table below.

* RCP6 does not include a controller. RCP6S includes a built-in controller.
** Preview: Cleanroom type RCP6(S)CR-WSA10C comes later.

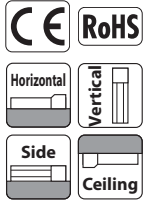

*Depending on the model, there may be some limitations to using the vertical, side, and ceiling mount positions. Please contact IAI for more information regarding mounting positions.



- POINT Selection Notes**
- (1) The maximum acceleration/deceleration is 1G for horizontal, and 0.5G for vertical use.
 - (2) The actuator specification displays the payload's maximum value, but it will vary depending on the acceleration and speed. Please refer to the "Selection Guidelines" (RCP6 Tables of Payload by Speed/Acceleration) on P.115 for more details.
 - (3) When performing push-motion operation, please confirm the push force of each model by checking the "Correlation diagram of push force and current limit" on P.113.

Correlation Diagrams of Speed and Payload

High-output enabled (*) with PCON/MCON/MSEL connected.
RCP6(S)-WSA10C Horizontal mount

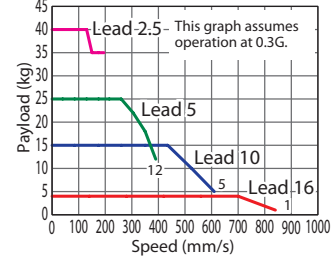

RCP6(S)-WSA10C Vertical mount

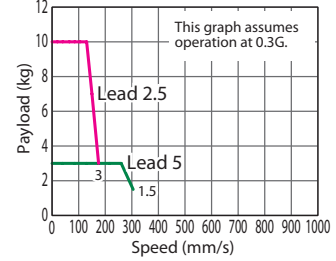

(*) For high output setting to OFF, refer to the RCP6 manual.

Actuator Specifications (*)

(*) For values of disabled high output controller setting refer to the RCP6 manual.

Lead and Payload

Model Number	Lead (mm)	Connected Controller	Max. Payload		Stroke (mm)
			Horizontal (kg)	Vertical (kg)	
RCP6(S)-WSA10C-WA-35P-16-①-②-③-④	16	High-output Enabled	4	-	50~500 (The increment of stroke is 50mm)
RCP6(S)-WSA10C-WA-35P-10-①-②-③-④	10	High-output Enabled	15	-	
RCP6(S)-WSA10C-WA-35P-5-①-②-③-④	5	High-output Enabled	28	3	
RCP6(S)-WSA10C-WA-35P-2.5-①-②-③-④	2.5	High-output Enabled	40	10	

Legend: ① Stroke ② Applicable controller/I/O type ③ Cable length ④ Options

Stroke and Max. Speed

(Unit: mm/s)

Lead (mm)	Connected Controller	Max. Speed				
		50~300 (Every 50mm)	350 (mm)	400 (mm)	450 (mm)	500 (mm)
16	High-output Enabled	840			775	660
10	High-output Enabled	610		590	490	415
5	High-output Enabled	390 <350>	355 <350>	290	245	205
2.5	High-output Enabled	195 <175>	175	145	120	100

Values in brackets < > are for vertical use.

Cable Length

Cable Type	Cable Code
Standard	P (1m)
	S (3m)
	M (5m)
Specified Length	X06 (6m) ~ X10 (10m)
	X11 (11m) ~ X15 (15m)
	X16 (16m) ~ X20 (20m)
	R01 (1m) ~ R03 (3m)
Robot Cable	R04 (4m) ~ R05 (5m)
	R06 (6m) ~ R10 (10m)
	R11 (11m) ~ R15 (15m)
	R16 (16m) ~ R20 (20m)

* Refer to P.144 for more information regarding the maintenance cables.

Options

Name	Option Code	Reference Page
Brake	B	See P.105
Cable exit direction (Top)	CJT	See P.105
Cable exit direction (Right)	CJR	See P.105
Cable exit direction (Left) (*1)	CJL	See P.105
Cable exit direction (Bottom)	CJB	See P.105
High-precision specification (*2)	HPR	See P.108
Non-motor end specification	NM	See P.110
Slider roller specification	SR	See P.111

(*1) This option is not available for the straight type RCP6S-WSA10C with built-in controller.

(*2) Positioning repeatability is ±5µm for high-precision specification (HPR). High-precision specification option cannot be selected for lead 16.

Actuator Specifications

Item	Description
Drive system	Ball screw ø8mm, rolled C10
Positioning repeatability (*1)	±0.01mm [±0.005mm]
Lost motion	0.1mm or less
Base	Material: Aluminum with white alumite treatment
Static allowable moment	Ma: 271N·m, Mb: 271N·m, Mc: 553N·m
Dynamic allowable moment (*2)	Ma: 65.4N·m, Mb: 65.4N·m, Mc: 134N·m
Ambient operating temp. & humidity	0~40°C, 85% RH or less (Non-condensing)

(*1) Values in [] are for high-precision (for lead 2.5/5/10) specification.
(*2) Assumes a standard rated life of 5000km. The service life will vary depending on operation and installation conditions.

• Reference for overhang load length: Ma: 500mm or less, Mb, Mc: 500mm or less

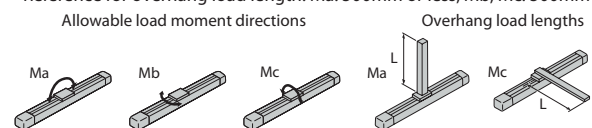

Please refer to the RoboCylinder General Catalog for more information regarding the directions of the allowable moment and overhang load length.

RCP6(S)-WSA12C



Model Specification Items	Series	Type	Encoder Type	Motor Type	Lead	Stroke	Applicable Controller/I/O Type	Cable Length	Options
	WSA12C	WA	42P						
	RCP6: Separate Controller RCP6S: Built-in Controller		WA: Battery-less Absolute	42P: Pulse Motor 42□ Size	20: 20mm 12: 12mm 6: 6mm 3: 3mm	50: 50mm 800: 800mm (50mm increments)	[RCP6] P3: PCON MCON MSEL [RCP6S] SE: SIO Type	N : None P : 1m S : 3m M : 5m X□ : Specified Length R□ : Robot Cable	Please refer to the options table below.

* RCP6 does not include a controller. RCP6S includes a built-in controller.
** Preview: Cleanroom type RCP6(S)CR-WSA12C comes later.

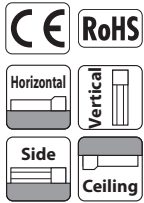

* Depending on the model, there may be some limitations to using the vertical, side, and ceiling mount positions. Please contact IAI for more information regarding mounting positions.



- POINT Selection Notes**
- (1) The maximum acceleration/deceleration is 1G for horizontal, and 0.5G for vertical use.
 - (2) The actuator specification displays the payload's maximum value, but it will vary depending on the acceleration and speed. Please refer to the "Selection Guidelines" (RCP6 Tables of Payload by Speed/Acceleration) on P.115 for more details.
 - (3) When performing push-motion operation, please confirm the push force of each model by checking the "Correlation diagram of push force and current limit" on P.113.
 - (4) Depending on the ambient operational temperature, duty control is necessary for the RCP6S (built-in controller type) with lead 3/6. Please refer to P.130 for more information.

Correlation Diagrams of Speed and Payload

High-output enabled (*) with PCON/MCON/MSEL connected.
RCP6(S)-WSA12C Horizontal mount

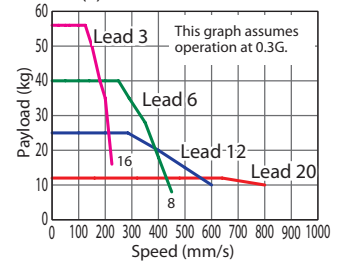

RCP6(S)-WSA12C Vertical mount

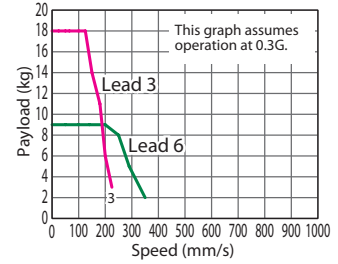

(*) For high output setting to OFF refer to the RCP6 manual.

Actuator Specifications (*)

(*) For values of disabled high output controller setting refer to the RCP6 manual.

Lead and Payload

Model Number	Lead (mm)	Connected Controller	Max. Payload		Stroke (mm)
			Horizontal (kg)	Vertical (kg)	
RCP6(S)-WSA12C-WA-42P-20-①-②-③-④	20	High-output Enabled	12	-	50~800 (The increment of stroke is 50mm)
RCP6(S)-WSA12C-WA-42P-12-①-②-③-④	12	High-output Enabled	25	-	
RCP6(S)-WSA12C-WA-42P-6-①-②-③-④	6	High-output Enabled	40	9	
RCP6(S)-WSA12C-WA-42P-3-①-②-③-④	3	High-output Enabled	60	18	

Legend: ① Stroke ② Applicable controller/I/O type ③ Cable length ④ Options

Stroke and Max. Speed

(Unit: mm/s)

Lead (mm)	Connected Controller	Max. Speed (mm/s)									
		50~350 (Every 50mm)	400 (mm)	450 (mm)	500 (mm)	550 (mm)	600 (mm)	650 (mm)	700 (mm)	750 (mm)	800 (mm)
20	High-output Enabled	800				740	650	580	520		
12	High-output Enabled	600		535	465	405	355	315	285		
6	High-output Enabled	450	435	365	310	265	230	200	175	155	140
3	High-output Enabled	225	215	180	150	130	115	100	85	75	70

Values in brackets < > are for vertical use.

Cable Length

Cable Type	Cable Code
Standard	P (1m)
	S (3m)
	M (5m)
Specified Length	X06 (6m) ~ X10 (10m)
	X11 (11m) ~ X15 (15m)
	X16 (16m) ~ X20 (20m)
	R01 (1m) ~ R03 (3m)
Robot Cable	R04 (4m) ~ R05 (5m)
	R06 (6m) ~ R10 (10m)
	R11 (11m) ~ R15 (15m)
	R16 (16m) ~ R20 (20m)

* Refer to P.144 for more information regarding the maintenance cables.

Options

Name	Option Code	Reference Page
Brake	B	See P.105
Cable exit direction (Top)	CJT	See P.105
Cable exit direction (Right)	CJR	See P.105
Cable exit direction (Left)	CJL	See P.105
Cable exit direction (Bottom)	CJB	See P.105
High-precision specification (*1)	HPR	See P.108
Non-motor end specification	NM	See P.110
Slider roller specification	SR	See P.111

Actuator Specifications

Item	Description
Drive system	Ball screw ø10mm, rolled C10
Positioning repeatability (*1)	±0.01mm [±0.005mm]
Lost motion	0.1mm or less
Base	Material: Aluminum with white alumite treatment
Static allowable moment	Ma: 311N·m, Mb: 311N·m, Mc: 827N·m
Dynamic allowable moment (*2)	Ma: 87.5N·m, Mb: 87.5N·m, Mc: 233N·m
Ambient operating temp. & humidity	0~40°C, 85% RH or less (Non-condensing)

(*1) Values in [] are for high-precision (for lead 3/6/12) specification.
(*2) Assumes a standard rated life of 5000km. The service life will vary depending on operation and installation conditions.

• Reference for overhang load length: Ma: 450mm or less, Mb, Mc: 450mm or less

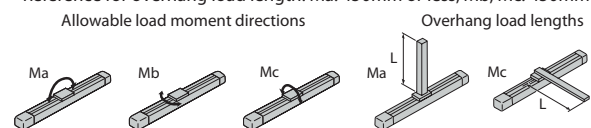

Please refer to the RoboCylinder General Catalog for more information regarding the directions of the allowable moment and overhang load length.

(*1) Positioning repeatability is ±5µm for high-precision specification (HPR). High-precision specification option cannot be selected for lead 20.

Dimensions

CAD drawings can be downloaded from our website.
www.robocylinder.de



*1 When the slider is returning to its home position, please be careful of interference from surrounding objects, as it will travel until it reaches the M.E.
M.E: Mechanical end S.E: Stroke end

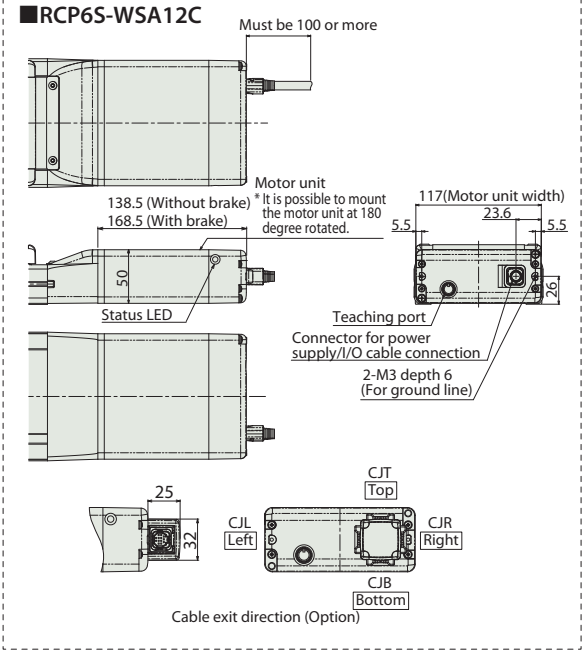
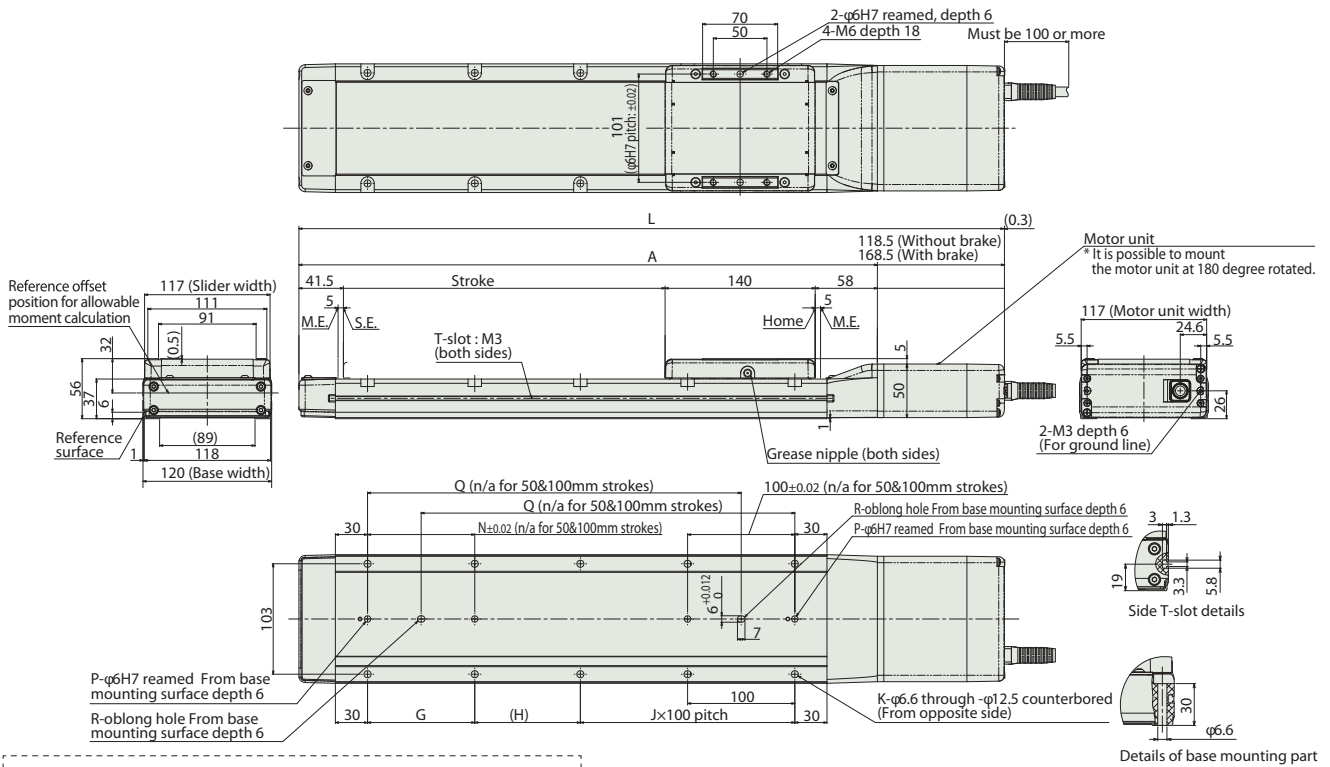

■ Dimensions and Mass by Stroke

Stroke	50	100	150	200	250	300	350	400	450	500	550	600	650	700	750	800	
L	RCP6 w/o brake	408	458	508	558	608	658	708	758	808	858	908	958	1008	1058	1108	1158
	RCP6 w/ brake	428	478	528	578	628	678	728	778	828	878	928	978	1028	1078	1128	1178
A	289.5	339.5	389.5	439.5	489.5	539.5	589.5	639.5	689.5	739.5	789.5	839.5	889.5	939.5	989.5	1039.5	
G	-	-	100	100	100	100	100	100	100	100	100	100	100	100	100	100	
H	148.5	198.5	248.5	298.5	348.5	398.5	448.5	498.5	548.5	598.5	648.5	698.5	748.5	798.5	848.5	898.5	
J	0	0	1	1	2	2	3	3	4	4	5	5	6	6	7	7	
K	4	4	8	8	10	10	12	12	14	14	16	16	18	18	20	20	
N	-	-	100	100	100	100	100	100	100	100	100	100	100	100	100	100	
P	1	1	2	2	2	2	2	2	2	2	2	2	2	2	2	2	
Q	-	-	198.5	248.5	298.5	348.5	398.5	448.5	498.5	548.5	598.5	648.5	698.5	748.5	798.5	848.5	
R	0	0	1	1	1	1	1	1	1	1	1	1	1	1	1	1	
Mass (kg)	RCP6 w/o brake	3.8	4.1	4.4	4.8	5.1	5.4	5.8	6.1	6.4	6.8	7.1	7.4	7.8	8.1	8.4	8.8
	RCP6 w/ brake	4.0	4.4	4.7	5.0	5.4	5.7	6.0	6.4	6.7	7.1	7.4	7.7	8.1	8.4	8.7	9.1
RCP6S	w/o brake	3.8	4.2	4.5	4.8	5.2	5.5	5.8	6.2	6.5	6.8	7.2	7.5	7.8	8.2	8.5	8.8
	w/ brake	4.1	4.4	4.7	5.1	5.4	5.7	6.1	6.4	6.7	7.1	7.4	7.8	8.1	8.4	8.8	9.1

Applicable Controllers

The RCP6 series actuators can be operated by the controllers indicated below. Please select the type depending on your intended use. * Please refer to P.147 for more information about the built-in controller of RCP6S series.

Name	External view	Max. number of controlled axes	Input power	Control method				Maximum number of positioning points	Reference page
				Positioner	Pulse train	Program	Network *Option		
PCON-CB/CGB		1	DC24V	*Option	*Option	-	DeviceNet, CC-Link, EtherCAT, EtherNet/IP, CompoNet	512 (768 for network spec.)	Please see P.132
MCON-C/CG		4	DC24V	This model is network-compatible only.				256	Please see the MCON catalog or manual.
MSEL-PC/PG		4	Single-phase 100~230VAC	-	-	•	Note: The type of compatible networks will vary depending on the controller. Please refer to reference page for more information.	30000	Please see the MSEL-PC/PG catalog or manual.

* Please select "high-output specification" as an option for the MCON. With the MCON, operation is possible only when the high-output specification is selected.

RCP6(S)-WSA14C



Model Specification Items	Series	Type	Encoder Type	Motor Type	Lead	Stroke	Applicable Controller/I/O Type	Cable Length	Options
	WSA14C	WA	56P						
	RCP6: Separate Controller RCP6S: Built-in Controller		WA: Battery-less Absolute	56P: Pulse Motor 56□ Size	24: 24mm 16: 16mm 8: 8mm 4: 4mm	50: 50mm 800: 800mm (50mm increments)	[RCP6] P3: PCON MCON MSEL [RCP6S] SE: SIO Type	N : None P : 1m S : 3m M : 5m X□□ : Specified Length R□□ : Robot Cable	Please refer to the options table below.

* RCP6 does not include a controller. RCP6S includes a built-in controller.
** Preview: Cleanroom type RCP6(S)CR-WSA14C comes later.

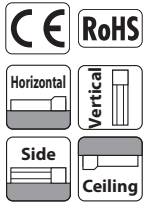

* Depending on the model, there may be some limitations to using the vertical, side, and ceiling mount positions. Please contact IAI for more information regarding mounting positions.



- POINT Selection Notes**
- (1) The maximum acceleration/deceleration is 1G for horizontal, and 0.5G for vertical use.
 - (2) The actuator specification displays the payload's maximum value, but it will vary depending on the acceleration and speed. Please refer to the "Selection Guidelines" (RCP6 Tables of Payload by Speed/Acceleration) on P.115 for more details.
 - (3) When performing push-motion operation, please confirm the push force of each model by checking the "Correlation diagram of push force and current limit" on P.113.
 - (4) Depending on the ambient operational temperature, duty control is necessary for the RCP6S (built-in controller type) with lead 4/8/16. Please refer to P.130 for more information.

Correlation Diagrams of Speed and Payload

High-output enabled (*) with PCON/MCON/MSEL connected.
RCP6(S)-WSA14C Horizontal mount

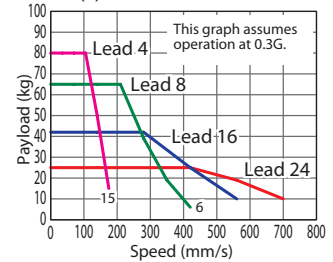

RCP6(S)-WSA14C Vertical mount

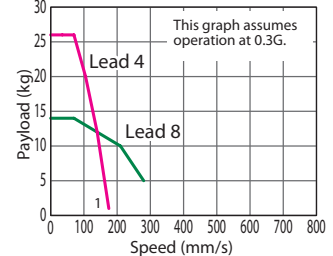

(*) For high output setting to OFF refer to the RCP6 manual.

Actuator Specifications (*)

(*) For values of disabled high output controller setting refer to the RCP6 manual.

Lead and Payload

Model Number	Lead (mm)	Connected Controller	Max. Payload		Stroke (mm)
			Horizontal (kg)	Vertical (kg)	
RCP6(S)-WSA14C-WA-56P-24-①-②-③-④	24	High-output Enabled	25	-	50~800 (The increment of stroke is 50mm)
RCP6(S)-WSA14C-WA-56P-16-①-②-③-④	16	High-output Enabled	50	-	
RCP6(S)-WSA14C-WA-56P-8-①-②-③-④	8	High-output Enabled	65	14	
RCP6(S)-WSA14C-WA-56P-4-①-②-③-④	4	High-output Enabled	80	26	

Legend: ① Stroke ② Applicable controller/I/O type ③ Cable length ④ Options

Stroke and Max. Speed

(Unit: mm/s)

Lead (mm)	Connected Controller	Max. Speed (mm/s)							
		50~500 (Every 50mm)	550 (mm)	600 (mm)	650 (mm)	700 (mm)	750 (mm)	800 (mm)	
24	High-output Enabled	700						665	
16	High-output Enabled	560				550	490	440	
8	High-output Enabled	420 <350>	400 <350>	350	305	270	240	215	
4	High-output Enabled	210 <175>	200 <175>	170	150	135	120	105	

Values in brackets < > are for vertical use.

Cable Length

Cable Type	Cable Code
Standard	P (1m)
	S (3m)
	M (5m)
Specified Length	X06 (6m) ~ X10 (10m)
	X11 (11m) ~ X15 (15m)
	X16 (16m) ~ X20 (20m)
	R01 (1m) ~ R03 (3m)
Robot Cable	R04 (4m) ~ R05 (5m)
	R06 (6m) ~ R10 (10m)
	R11 (11m) ~ R15 (15m)
	R16 (16m) ~ R20 (20m)

* Refer to P.144 for more information regarding the maintenance cables.

Options

Name	Option Code	Reference Page
Brake	B	See P.105
Cable exit direction (Top)	CJT	See P.105
Cable exit direction (Right)	CJR	See P.105
Cable exit direction (Left)	CJL	See P.105
Cable exit direction (Bottom)	CJB	See P.105
High-precision specification (*1)	HPR	See P.108
Non-motor end specification	NM	See P.110
Slider roller specification	SR	See P.111

Actuator Specifications

Item	Description
Drive system	Ball screw ø12mm, rolled C10
Positioning repeatability (*1)	±0.01mm [±0.005mm]
Lost motion	0.1mm or less
Base	Material: Aluminum with white alumite treatment
Static allowable moment	Ma: 462N·m, Mb: 462N·m, Mc: 1170N·m
Dynamic allowable moment (*2)	Ma: 122N·m, Mb: 122N·m, Mc: 308N·m
Ambient operating temp. & humidity	0~40°C, 85% RH or less (Non-condensing)

(*1) Values in [] are for high-precision (for lead 4/8) specification.
(*2) Assumes a standard rated life of 5000km. The service life will vary depending on operation and installation conditions.

• Reference for overhang load length: Ma: 550mm or less, Mb, Mc: 550mm or less

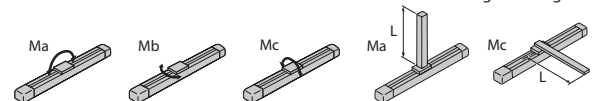

Please refer to the RoboCylinder General Catalog for more information regarding the directions of the allowable moment and overhang load length.

(*1) Positioning repeatability is ±5µm for high-precision specification (HPR).
High-precision specification option cannot be selected for lead 16 or 24.

Dimensions

CAD drawings can be downloaded from our website.
www.robocylinder.de



*1 When the slider is returning to its home position, please be careful of interference from surrounding objects, as it will travel until it reaches the M.E.
M.E: Mechanical end S.E: Stroke end

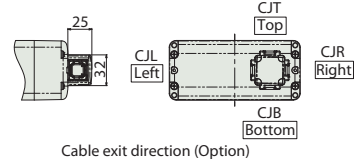
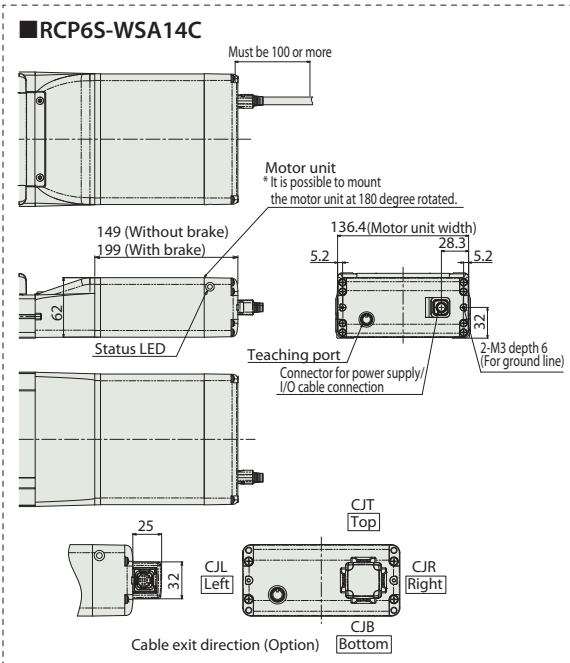
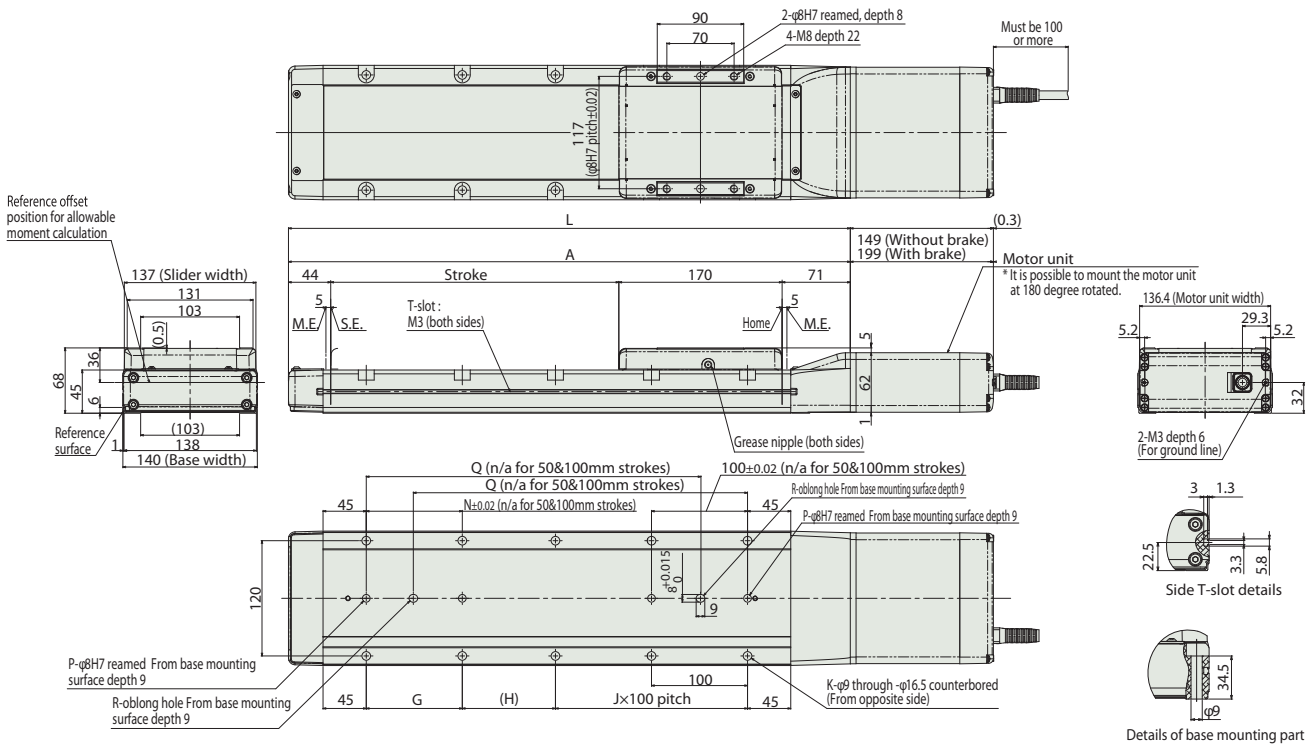

■ Dimensions and Mass by Stroke

Stroke	50	100	150	200	250	300	350	400	450	500	550	600	650	700	750	800		
L	RCP6	w/o brake	484	534	584	634	684	734	784	834	884	934	984	1034	1084	1134	1184	1234
		w/ brake	534	584	634	684	734	784	834	884	934	984	1034	1084	1134	1184	1234	1284
	RCP6S	w/o brake	484	534	584	634	684	734	784	834	884	934	984	1034	1084	1134	1184	1234
		w/ brake	534	584	634	684	734	784	834	884	934	984	1034	1084	1134	1184	1234	1284
A	335	385	435	485	535	585	635	685	735	785	835	885	935	985	1035	1085		
G	-	-	100	100	100	100	100	100	100	100	100	100	100	100	100	100		
H	147	197	47	97	47	97	47	97	47	97	47	97	47	97	47	97		
J	0	0	1	1	2	2	3	3	4	4	5	5	6	6	7	7		
K	4	4	8	8	10	10	12	12	14	14	16	16	18	18	20	20		
N	-	-	100	100	100	100	100	100	100	100	100	100	100	100	100	100		
P	1	1	2	2	2	2	2	2	2	2	2	2	2	2	2	2		
Q	-	-	198	248	298	348	398	448	498	548	598	648	698	748	798	848		
R	0	0	1	1	1	1	1	1	1	1	1	1	1	1	1	1		
Mass (kg)	RCP6	w/o brake	6.6	7.0	7.5	8.0	8.5	8.9	9.4	9.9	10.4	10.9	11.3	11.8	12.3	12.8	13.2	13.7
		w/ brake	7.0	7.5	8.0	8.5	8.9	9.4	9.9	10.4	10.9	11.3	11.8	12.3	12.8	13.2	13.7	14.2
	RCP6S	w/o brake	6.6	7.1	7.6	8.0	8.5	9.0	9.5	9.9	10.4	10.9	11.4	11.9	12.3	12.8	13.3	13.8
		w/ brake	7.1	7.6	8.0	8.5	9.0	9.5	9.9	10.4	10.9	11.4	11.8	12.3	12.8	13.3	13.8	14.2

Applicable Controllers

The RCP6 series actuators can be operated by the controllers indicated below. Please select the type depending on your intended use. * Please refer to P.147 for more information about the built-in controller of RCP6S series.

Name	External view	Max. number of controlled axes	Input power	Control method				Maximum number of positioning points	Reference page
				Positioner	Pulse train	Program	Network *Option		
PCON-CB/CGB		1	DC24V	● *Option	● *Option	-	 	512 (768 for network spec.)	Please see P.132
MCON-C/CG		4		This model is network-compatible only.					
MSEL-PC/PG		4	Single-phase 100~230VAC	-	-	●	Note: The type of compatible networks will vary depending on the controller. Please refer to reference page for more information.	30000	Please see the MSEL-PC/PG catalog or manual.

* Please select "high-output specification" as an option for the MCON. With the MCON, operation is possible only when the high-output specification is selected.

RCP6(S)-WSA16C



Model Specification Items

Series	Type	Encoder Type	Motor Type	Lead	Stroke	Applicable Controller/I/O Type	Cable Length	Options
RCP6: Separate Controller RCP6S: Built-in Controller	WSA16C	WA: Battery-less Absolute	56SP: High-thrust Pulse Motor 56□ Size	20:20mm 10:10mm 5: 5mm	50: 50mm 1100: 1100mm (50mm increments)	[RCP6] P4: PCON-CFB/CGFB [RCP6S] SE: SIO Type	N : None P : 1m S : 3m M : 5m X□□ : Specified Length R□□ : Robot Cable	Please refer to the options table below.

* RCP6 does not include a controller. RCP6S includes a built-in controller.
** Preview: Cleanroom type RCP6(S)CR-WSA16C comes later.

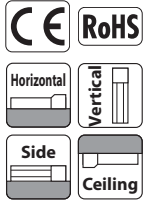

* Depending on the model, there may be some limitations to using the vertical, side, and ceiling mount positions. Please contact IAI for more information regarding mounting positions.



- POINT Selection Notes**
- (1) The maximum acceleration/deceleration is 1G for horizontal, and 0.5G for vertical use.
 - (2) The actuator specification displays the payload's maximum value, but it will vary depending on the acceleration and speed. Please refer to the "Selection Guidelines" (RCP6 Tables of Payload by Speed/Acceleration) on P.115 for more details.
 - (3) When performing push-motion operation, please confirm the push force of each model by checking the "Correlation diagram of push force and current limit" on P.113.
 - (4) The service life of an actuator with lead 5 varies depending on the payload when using vertically. Please refer to P. 114 for more information.

Correlation Diagrams of Speed and Payload

PCON connected.
RCP6(S)-WSA16C Horizontal mount

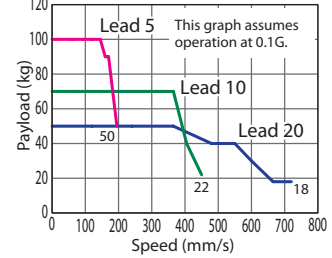

RCP6(S)-WSA16C Vertical mount

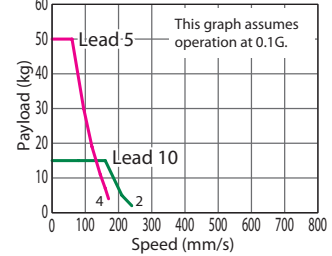

Actuator Specifications

Lead and Payload

Model Number	Lead (mm)	Max. Payload (kg)		Stroke (mm)
		Horizontal	Vertical	
RCP6(S)-WSA16C-WA-56SP-20-①-②-③-④	20	50	-	50~1100 (The increment of stroke is 50mm)
RCP6(S)-WSA16C-WA-56SP-10-①-②-③-④	10	70	15	
RCP6(S)-WSA16C-WA-56SP-5-①-②-③-④	5	100	50	

Legend: ① Stroke ② Applicable controller/I/O type ③ Cable length ④ Options

Stroke and Max. Speed

(Unit: mm/s)

Lead (mm)	50~650 (Every 50mm)	700 (mm)	750 (mm)	800 (mm)	850 (mm)	900 (mm)	950 (mm)	1000 (mm)	1050 (mm)	1100 (mm)
20	720	715	645	590	535	490	450	415		
10	450 <240>	440 <240>	395 <240>	355 <240>	320 <240>	290 <240>	265 <240>	240	225	205
5	195 <170>	175 <170>	160	145	130	120	110	100		

Values in brackets < > are for vertical use.

Cable Length

Cable Type	Cable Code
Standard	P (1m)
	S (3m)
	M (5m)
Specified Length	X06 (6m) ~ X10 (10m)
	X11 (11m) ~ X15 (15m)
	X16 (16m) ~ X20 (20m)
	R01 (1m) ~ R03 (3m)
Robot Cable	R04 (4m) ~ R05 (5m)
	R06 (6m) ~ R10 (10m)
	R11 (11m) ~ R15 (15m)
	R16 (16m) ~ R20 (20m)

* Refer to P.144 for more information regarding the maintenance cables.

Options

Name	Option Code	Reference Page
Brake	B	See P.105
Cable exit direction (Top)	CJT	See P.105
Cable exit direction (Right)	CJR	See P.105
Cable exit direction (Left)	CJL	See P.105
Cable exit direction (Bottom)	CJB	See P.105
High-precision specification (*1)	HPR	See P.108
Non-motor end specification	NM	See P.110
Slider roller specification	SR	See P.111

Actuator Specifications

Item	Description
Drive system	Ball screw ø16mm, rolled C10
Positioning repeatability (*1)	±0.01mm [±0.005mm]
Lost motion	0.1mm or less
Base	Material: Aluminum with white alumite treatment
Static allowable moment	Ma: 642N·m, Mb: 642N·m, Mc: 1610N·m
Dynamic allowable moment (*2)	Ma: 161N·m, Mb: 161N·m, Mc: 404N·m
Ambient operating temp. & humidity	0~40°C, 85% RH or less (Non-condensing)

(*1) Values in [] are for high-precision (for lead 5/10) specification.
(*2) Assumes a standard rated life of 5000km. The service life will vary depending on operation and installation conditions.

• Reference for overhang load length: Ma: 650mm or less, Mb, Mc: 650mm or less

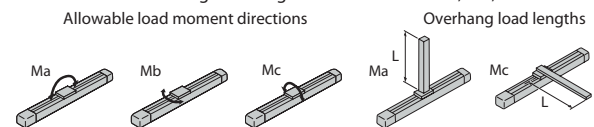

Please refer to the RoboCylinder General Catalog for more information regarding the directions of the allowable moment and overhang load length.

(*1) Positioning repeatability is ±5µm for high-precision specification (HPR). High-precision specification option cannot be selected for lead 20.

Dimensions

CAD drawings can be downloaded from our website.
www.robocylinder.de



*1 When the slider is returning to its home position, please be careful of interference from surrounding objects, as it will travel until it reaches the M.E.
M.E: Mechanical end
S.E: Stroke end

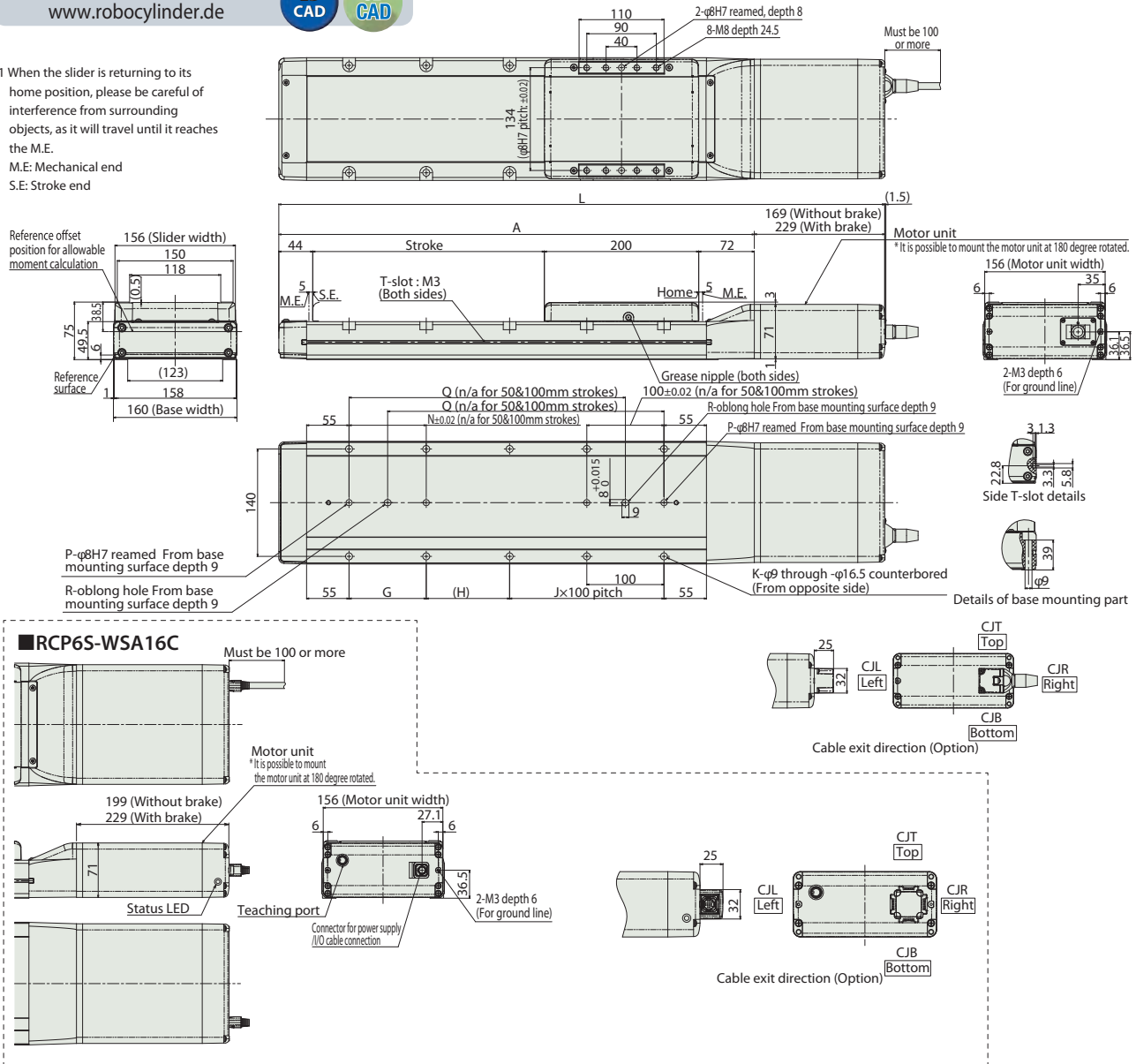

■ Dimensions and Mass by Stroke

L	Stroke	50	100	150	200	250	300	350	400	450	500	550	600	650	700	750	800	850	900	950	1000	1050	1100	
		RCP6	w/o brake	535	585	635	685	735	785	835	885	935	985	1035	1085	1135	1185	1235	1285	1335	1385	1435	1485	1535
	w/ brake	595	645	695	745	795	845	895	945	995	1045	1095	1145	1195	1245	1295	1345	1395	1445	1495	1545	1595	1645	
RCP6S	w/o brake	565	615	665	715	765	815	865	915	965	1015	1065	1115	1165	1215	1265	1315	1365	1415	1465	1515	1565	1615	
	w/ brake	595	645	695	745	795	845	895	945	995	1045	1095	1145	1195	1245	1295	1345	1395	1445	1495	1545	1595	1645	
A		366	416	466	516	566	616	666	716	766	816	866	916	966	1016	1066	1116	1166	1216	1266	1316	1366	1416	
G		-	-	100	100	100	100	100	100	100	100	100	100	100	100	100	100	100	100	100	100	100	100	
H		158	208	58	108	58	108	58	108	58	108	58	108	58	108	58	108	58	108	58	108	58	108	
J		0	0	1	1	2	2	3	3	4	4	5	5	6	6	7	7	8	8	9	9	10	10	
K		4	4	8	8	10	10	12	12	14	14	16	16	18	18	20	20	22	22	24	24	26	26	
N		-	-	100	100	100	100	100	100	100	100	100	100	100	100	100	100	100	100	100	100	100	100	
P		1	1	2	2	2	2	2	2	2	2	2	2	2	2	2	2	2	2	2	2	2	2	
Q		-	-	208	258	308	358	408	458	508	558	608	658	708	758	808	858	908	958	1008	1058	1108	1158	
R		0	0	1	1	1	1	1	1	1	1	1	1	1	1	1	1	1	1	1	1	1	1	
Mass (kg)	RCP6	w/o brake	8.7	9.3	9.9	10.5	11.1	11.7	12.3	12.9	13.4	14.0	14.6	15.2	15.8	16.4	17.0	17.6	18.1	18.7	19.3	19.9	20.5	21.1
		w/ brake	9.6	10.1	10.7	11.3	11.8	12.4	13.0	13.5	14.1	14.7	15.2	15.8	16.3	16.9	17.5	18.1	18.6	19.2	19.7	20.3	20.9	21.4
	RCP6S	w/o brake	8.9	9.5	10.1	10.7	11.2	11.8	12.4	13.0	13.6	14.2	14.8	15.4	15.9	16.5	17.1	17.7	18.3	18.9	19.5	20.1	20.6	21.2
		w/ brake	9.6	10.2	10.7	11.3	11.9	12.5	13.0	13.6	14.1	14.7	15.3	15.8	16.4	17.0	17.5	18.1	18.7	19.2	19.8	20.4	20.9	21.5

Applicable Controllers

The RCP6 series actuators can be operated by the controllers indicated below. Please select the type depending on your intended use. * Please refer to P.147 for more information about the built-in controller of RCP6S series.

Name	External view	Max. number of controlled axes	Input power	Positioner	Pulse train	Program	Control method		Maximum number of positioning points	Reference page
							Network *Option			
PCON-CFB/CGFB		1	DC24V	● *Option	● *Option	-	DeviceNet	CompoNet	512 (768 for network spec.)	Please see P.132
							EtherNet/IP			

RCP6(S)-WSA10R

±10μm Standard
Simple Dust-proof
Battery-less Absolute
Motor Unit Coupled
Side-mounted Motor
Body Width 100* mm
24V Pulse Motor

Model Specification Items	Series	Type	Encoder Type	Motor Type	Lead	Stroke	Applicable Controller/I/O Type	Cable Length	Options
	□	—	WA	35P	□	□	□	□	□
	RCP6: Separate Controller RCP6S: Built-in Controller		WA: Battery-less Absolute	35P: Pulse Motor 35□ Size	16: 16mm 10: 10mm 5: 5mm 2.5: 2.5mm	50: 50mm ↑ 500: 500mm (50mm increments)	[RCP6] P3: PCON MCON MSEL [RCP6S] SE: SIO Type	N : None P : 1m S : 3m M : 5m X□□ : Specified Length R□□ : Robot Cable	* Body width does not include the width of the side-mounted motor. Please refer to the options table below. * Please make sure to specify either ML or MR when ordering the side-mounted motor type.

* RCP6 does not include a controller. RCP6S includes a built-in controller.

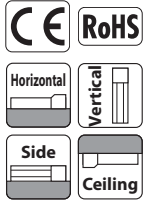

* Depending on the model, there may be some limitations to using the vertical, side, and ceiling mount positions. Please contact IAI for more information regarding mounting positions.



The figure above is the motor side-mounted to the left (ML).

- POINT Selection Notes**
- (1) The maximum acceleration/deceleration is 1G for horizontal, and 0.5G for vertical use.
 - (2) The actuator specification displays the payload's maximum value, but it will vary depending on the acceleration and speed. Please refer to the "Selection Guidelines" (RCP6 Tables of Payload by Speed/Acceleration) on P.115 for more details.
 - (3) When performing push-motion operation, please confirm the push force of each model by checking the "Correlation diagram of push force and current limit" on P.113.

Correlation Diagrams of Speed and Payload

High-output enabled (*) with PCON/MCON/MSEL connected.
RCP6(S)-WSA10R Horizontal mount

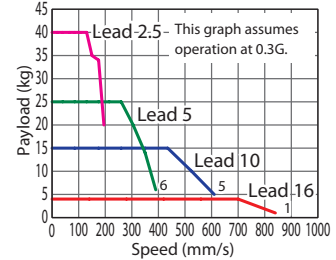

RCP6(S)-WSA10R Vertical mount

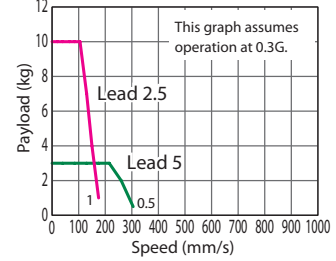

(*) For high output setting to OFF, refer to the RCP6 manual.

Actuator Specifications (*)

(*) For values of disabled high output controller setting refer to the RCP6 manual.

Lead and Payload

Model Number	Lead (mm)	Connected Controller	Max. Payload		Stroke (mm)
			Horizontal (kg)	Vertical (kg)	
RCP6(S)-WSA10R-WA-35P-16-①-②-③-④	16	High-output Enabled	4	-	50~500 (The increment of stroke is 50mm)
RCP6(S)-WSA10R-WA-35P-10-①-②-③-④	10	High-output Enabled	15	-	
RCP6(S)-WSA10R-WA-35P-5-①-②-③-④	5	High-output Enabled	28	3	
RCP6(S)-WSA10R-WA-35P-2.5-①-②-③-④	2.5	High-output Enabled	40	10	

Legend: ① Stroke ② Applicable controller/I/O type ③ Cable length ④ Options

Stroke and Max. Speed

(Unit: mm/s)

Lead (mm)	Connected Controller	Stroke (mm)				
		50~300 (Every 50mm)	350 (mm)	400 (mm)	450 (mm)	500 (mm)
16	High-output Enabled	840			775	660
10	High-output Enabled	610	590	490	415	
5	High-output Enabled	390 <305>	355 <305>	290	245	205
2.5	High-output Enabled	195 <175>	175	145	120	100

Values in brackets < > are for vertical use.

Cable Length

Cable Type	Cable Code
Standard	P (1m)
	S (3m)
	M (5m)
Specified Length	X06 (6m) ~ X10 (10m)
	X11 (11m) ~ X15 (15m)
	X16 (16m) ~ X20 (20m)
	X21 (21m) ~ X25 (25m)
Robot Cable	R01 (1m) ~ R03 (3m)
	R04 (4m) ~ R05 (5m)
	R06 (6m) ~ R10 (10m)
	R11 (11m) ~ R15 (15m)
	R16 (16m) ~ R20 (20m)
	R21 (21m) ~ R25 (25m)

* Refer to P.144 for more information regarding the maintenance cables.

Options

Name	Option Code	Reference Page
Brake	B	See P.105
Cable exit direction (Outside)	CJO	See P.105
Motor side-mounted to the left	ML	See P.109
Motor side-mounted to the right	MR	See P.109
Non-motor end specification	NM	See P.110
Slider roller specification	SR	See P.111

Actuator Specifications

Item	Description
Drive system	Ball screw ø8mm, rolled C10
Positioning repeatability	±0.01mm
Lost motion	0.1mm or less
Base	Material: Aluminum with white alumite treatment
Static allowable moment	Ma: 271N·m, Mb: 271N·m, Mc: 553N·m
Dynamic allowable moment (*)	Ma: 65.4N·m, Mb: 65.4N·m, Mc: 134N·m
Ambient operating temp. & humidity	0~40°C, 85% RH or less (Non-condensing)

(*)1 Assumes a standard rated life of 5000km. The service life will vary depending on operation and installation conditions.

- Reference for overhang load length: Ma: 500mm or less, Mb, Mc: 500mm or less

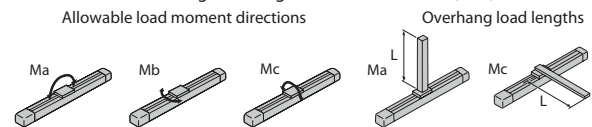

Please refer to the RoboCylinder General Catalog for more information regarding the directions of the allowable moment and overhang load length.

Dimensions

CAD drawings can be downloaded from our website.
www.robocylinder.de



*1 When the slider is returning to its home position, please be careful of interference from surrounding objects, as it will travel until it reaches the M.E.
M.E: Mechanical end S.E: Stroke end

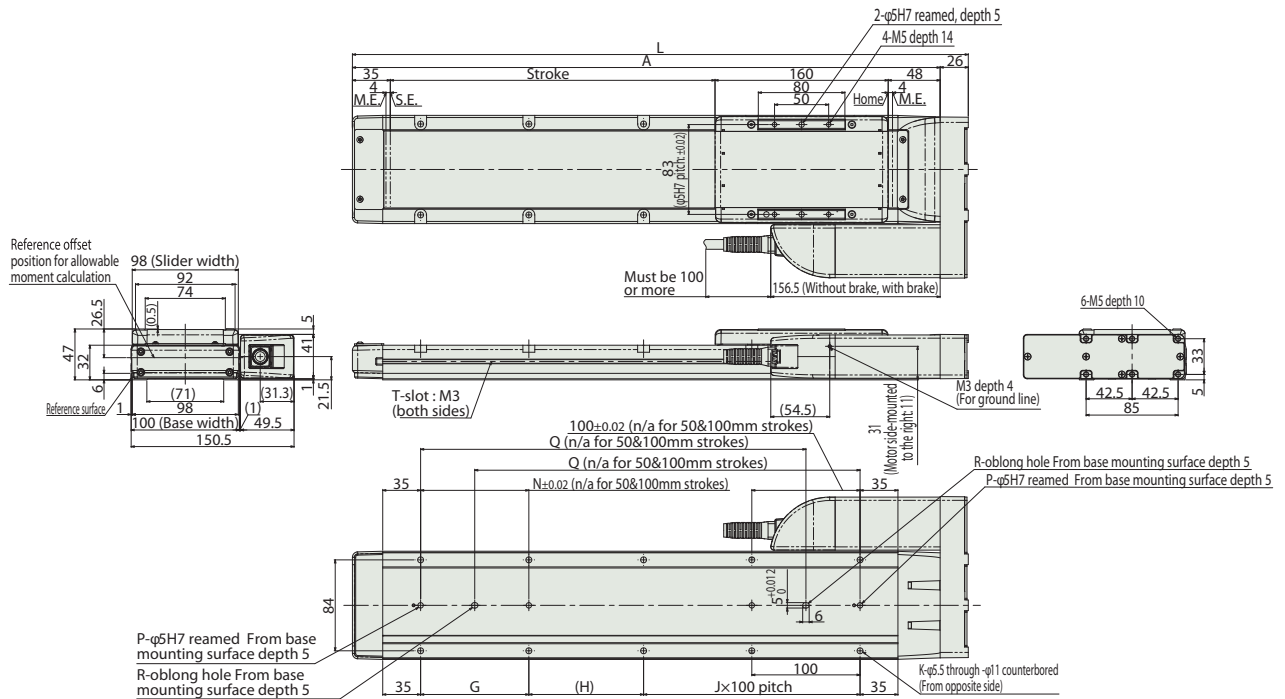

RCP6S-WSA10R

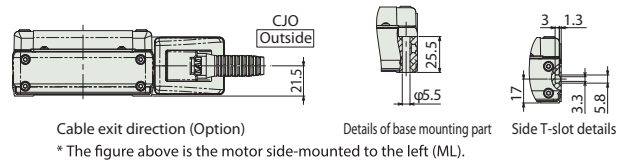
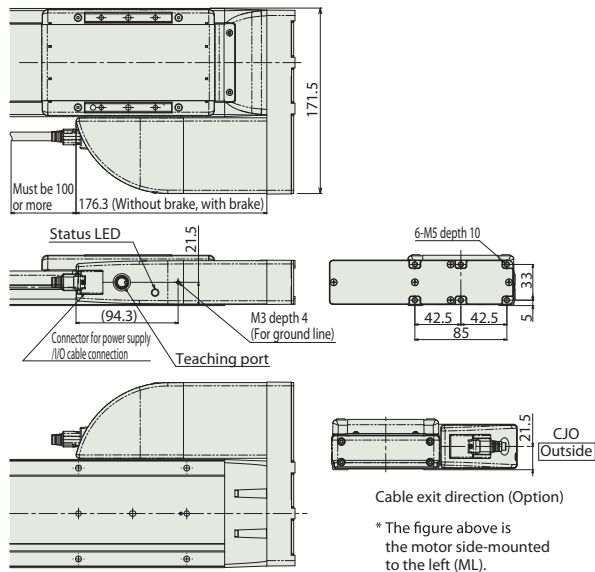

Dimensions and Mass by Stroke

Stroke	50	100	150	200	250	300	350	400	450	500		
L	319	369	419	469	519	569	619	669	719	769		
A	293	343	393	443	493	543	593	643	693	743		
G	-	-	100	100	100	100	100	100	100	100		
H	156	206	56	106	56	106	56	106	56	106		
J	0	0	1	1	2	2	3	3	4	4		
K	4	4	8	8	10	10	12	12	14	14		
N	-	-	100	100	100	100	100	100	100	100		
P	1	1	2	2	2	2	2	2	2	2		
Q	-	-	206	256	306	356	406	456	506	556		
R	0	0	1	1	1	1	1	1	1	1		
Mass (kg)	RCP6	w/o brake	2.9	3.2	3.4	3.6	3.9	4.1	4.4	4.6	4.8	5.1
		w/ brake	3.0	3.2	3.5	3.7	3.9	4.2	4.4	4.7	4.9	5.2
	RCP6S	w/o brake	3.0	3.3	3.5	3.8	4.0	4.3	4.5	4.7	5.0	5.2
		w/ brake	3.1	3.4	3.6	3.8	4.1	4.3	4.6	4.8	5.0	5.3

Applicable Controllers

The RCP6 series actuators can be operated by the controllers indicated below. Please select the type depending on your intended use. * Please refer to P.147 for more information about the built-in controller of RCP6S series.

Name	External view	Max. number of controlled axes	Input power	Control method				Maximum number of positioning points	Reference page
				Positioner	Pulse train	Program	Network *Option		
PCON-CB/CGB		1	DC24V	●	●	-	DeviceNet CC-link EtherCAT EtherNet/IP CompoNet	512 (768 for network spec.)	Please see P.132
MCON-C/CG		4		This model is network-compatible only.					
MSEL-PC/PG		4	Single-phase 100~230VAC	-	-	●	Note: The type of compatible networks will vary depending on the controller. Please refer to reference page for more information.	30000	Please see the MSEL-PC/PG catalog or manual.

* Please select "high-output specification" as an option for the MCON. With the MCON, operation is possible only when the high-output specification is selected.

RCP6(S)-WSA12R

±10μm Standard
Simple Dust-proof
Battery-less Absolute
Motor Unit Coupled
Side-mounted Motor
Body Width 120* mm
24V Pulse Motor

Model Specification Items	Series	Type	Encoder Type	Motor Type	Lead	Stroke	Applicable Controller/I/O Type	Cable Length	Options
	□	—	WA	42P	□	□	□	□	□
	—	—	—	—	—	—	—	—	—
	RCP6: Separate Controller RCP6S: Built-in Controller		WA: Battery-less Absolute	42P: Pulse Motor 42□□ Size	20: 20mm 12: 12mm 6: 6mm 3: 3mm	50: 50mm ? 800: 800mm (50mm increments)	[RCP6] P3: PCON MCON MSEL [RCP6S] SE: SIO Type	N : None P : 1m S : 3m M : 5m X□□ : Specified Length R□□ : Robot Cable	Please refer to the options table below. *Please make sure to specify either ML or MR when ordering the side-mounted motor type.

* RCP6 does not include a controller. RCP6S includes a built-in controller.

* Body width does not include the width of the side-mounted motor.

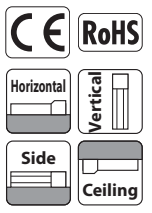

* Depending on the model, there may be some limitations to using the vertical, side, and ceiling mount positions. Please contact IAI for more information regarding mounting positions.

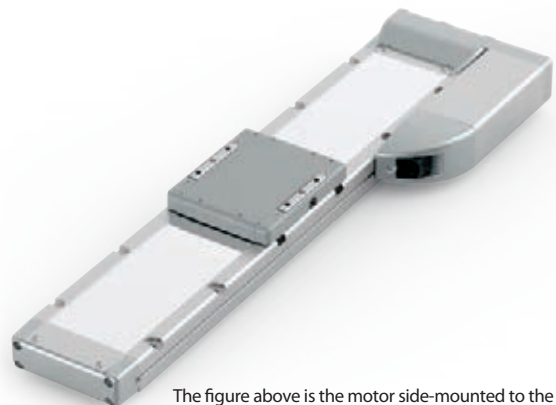

The figure above is the motor side-mounted to the left (ML).

- POINT Selection Notes**

 - (1) The maximum acceleration/deceleration is 1G for horizontal, and 0.5G for vertical use.
 - (2) The actuator specification displays the payload's maximum value, but it will vary depending on the acceleration and speed. Please refer to the "Selection Guidelines" (RCP6 Tables of Payload by Speed/Acceleration) on P.115 for more details.
 - (3) When performing push-motion operation, please confirm the push force of each model by checking the "Correlation diagram of push force and current limit" on P.113.
 - (4) Depending on the ambient operational temperature, duty control is necessary for the RCP6S (built-in controller type) with lead 3/6. Please refer to P.130 for more information.

Correlation Diagrams of Speed and Payload

High-output enabled (*) with PCON/MCON/MSEL connected.
RCP6(S)-WSA12R Horizontal mount

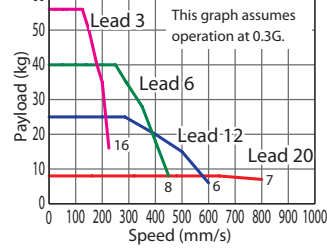

RCP6(S)-WSA12R Vertical mount

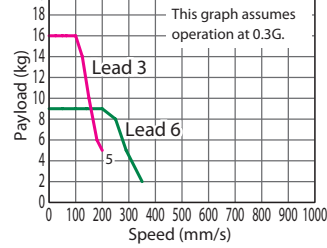

(*) For high output setting to OFF refer to the RCP6 manual.

Actuator Specifications (*)

Model Number	Lead (mm)	Connected Controller	Max. Payload		Stroke (mm)	Stroke and Max. Speed (Unit: mm/s)												
			Horizontal (kg)	Vertical (kg)		Lead	Connected Controller	50~350 (Every 50mm)	400	450	500	550	600	650	700	750	800	
RCP6(S)-WSA12R-WA-42P-20-①-②-③-④	20	High-output Enabled	12	-	50~800 (The increment of stroke is 50mm)	20	High-output Enabled	800		740	650	580	520					
RCP6(S)-WSA12R-WA-42P-12-①-②-③-④	12	High-output Enabled	25	-		12	High-output Enabled	600		535	465	405	355	315	285			
RCP6(S)-WSA12R-WA-42P-6-①-②-③-④	6	High-output Enabled	40	9		6	High-output Enabled	450	435	365	310	265	230	200	175	155	140	
RCP6(S)-WSA12R-WA-42P-3-①-②-③-④	3	High-output Enabled	60	16		3	High-output Enabled	225	215	180	150	130	115	100	85	75	70	

Legend: ① Stroke ② Applicable controller/I/O type ③ Cable length ④ Options

Values in brackets < > are for vertical use.

Cable Length

Cable Type	Cable Code
Standard	P (1m)
	S (3m)
	M (5m)
Specified Length	X06 (6m) ~ X10 (10m)
	X11 (11m) ~ X15 (15m)
	X16 (16m) ~ X20 (20m)
Robot Cable	R01 (1m) ~ R03 (3m)
	R04 (4m) ~ R05 (5m)
	R06 (6m) ~ R10 (10m)
	R11 (11m) ~ R15 (15m)
	R16 (16m) ~ R20 (20m)

* Refer to P.144 for more information regarding the maintenance cables.

Options

Name	Option Code	Reference Page
Brake	B	See P.105
Cable exit direction (Outside)	CJO	See P.105
Motor side-mounted to the left	ML	See P.109
Motor side-mounted to the right	MR	See P.109
Non-motor end specification	NM	See P.110
Slider roller specification	SR	See P.111

Actuator Specifications

Item	Description
Drive system	Ball screw ø10mm, rolled C10
Positioning repeatability	±0.01mm
Lost motion	0.1mm or less
Base	Material: Aluminum with white alumite treatment
Static allowable moment	Ma: 311N·m, Mb: 311N·m, Mc: 827N·m
Dynamic allowable moment (*)	Ma: 87.5N·m, Mb: 87.5N·m, Mc: 233N·m
Ambient operating temp. & humidity	0~40°C, 85% RH or less (Non-condensing)

(*)1 Assumes a standard rated life of 5000km. The service life will vary depending on operation and installation conditions.

• Reference for overhang load length: Ma: 450mm or less, Mb, Mc: 450mm or less

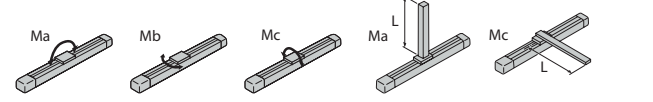

Please refer to the RoboCylinder General Catalog for more information regarding the directions of the allowable moment and overhang load length.

Dimensions

CAD drawings can be downloaded from our website.

www.robocylinder.de



*1 When the slider is returning to its home position, please be careful of interference from surrounding objects, as it will travel until it reaches the M.E.
M.E: Mechanical end S.E: Stroke end

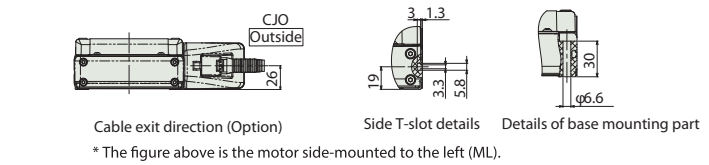
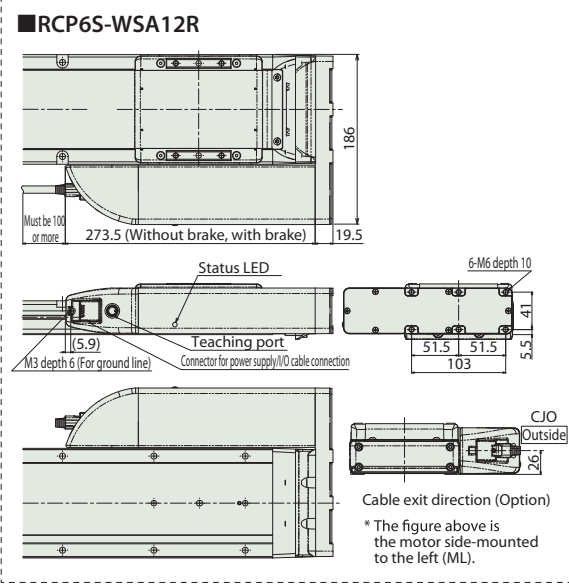
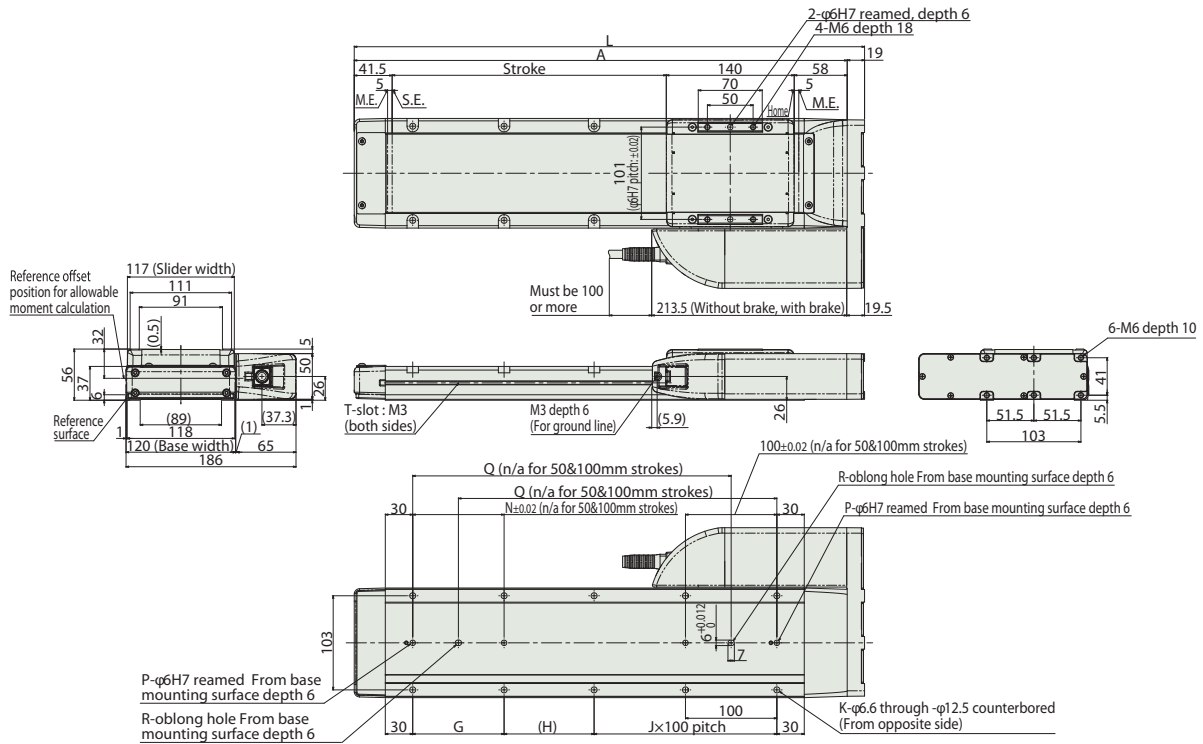

Dimensions and Mass by Stroke

Stroke	50	100	150	200	250	300	350	400	450	500	550	600	650	700	750	800
L	308.5	358.5	408.5	458.5	508.5	558.5	608.5	658.5	708.5	758.5	808.5	858.5	908.5	958.5	1008.5	1058.5
A	289.5	339.5	389.5	439.5	489.5	539.5	589.5	639.5	689.5	739.5	789.5	839.5	889.5	939.5	989.5	1039.5
G			100	100	100	100	100	100	100	100	100	100	100	100	100	100
H	148.5	198.5	248.5	298.5	348.5	398.5	448.5	498.5	548.5	598.5	648.5	698.5	748.5	798.5	848.5	898.5
J	0	0	1	1	2	2	3	3	4	4	5	5	6	6	7	7
K	4	4	8	8	10	10	12	12	14	14	16	16	18	18	20	20
N	-	-	100	100	100	100	100	100	100	100	100	100	100	100	100	100
P	1	1	2	2	2	2	2	2	2	2	2	2	2	2	2	2
Q	-	-	198.5	248.5	298.5	348.5	398.5	448.5	498.5	548.5	598.5	648.5	698.5	748.5	798.5	848.5
R	0	0	1	1	1	1	1	1	1	1	1	1	1	1	1	1
Mass (kg)	RCP6 w/o brake	4.1	4.4	4.7	5.1	5.4	5.7	6.1	6.4	6.7	7.1	7.4	7.7	8.1	8.4	8.7
	RCP6 w/ brake	4.1	4.5	4.8	5.1	5.5	5.8	6.1	6.5	6.8	7.1	7.5	7.8	8.1	8.5	8.8
RCP6S	w/o brake	4.2	4.5	4.9	5.2	5.5	5.9	6.2	6.5	6.9	7.2	7.5	7.9	8.2	8.5	8.9
	w/ brake	4.3	4.6	4.9	5.3	5.6	5.9	6.3	6.6	6.9	7.3	7.6	7.9	8.3	8.6	8.9

Applicable Controllers

The RCP6 series actuators can be operated by the controllers indicated below. Please select the type depending on your intended use. * Please refer to P.147 for more information about the built-in controller of RCP6S series.

Name	External view	Max. number of controlled axes	Input power	Control method				Maximum number of positioning points	Reference page
				Positioner	Pulse train	Program	Network *Option		
PCON-CB/CGB		1	DC24V	●	●	-	DeviceNet CC-Link EtherCAT EtherNet/IP CompoNet	512 (768 for network spec.)	Please see P.132
MCON-C/CG		4		This model is network-compatible only.					
MSEL-PC/PG		4	Single-phase 100~230VAC	-	-	●	Note: The type of compatible networks will vary depending on the controller. Please refer to reference page for more information.	30000	Please see the MSEL-PC/PG catalog or manual.

* Please select "high-output specification" as an option for the MCON. With the MCON, operation is possible only when the high-output specification is selected.

RCP6(S)-WSA14R

±10μm Standard
Simple Dust-proof
Battery-less Absolute
Motor Unit Coupled
Side-mounted Motor
Body Width 140* mm
24V Pulse Motor

Model Specification Items	Series	Type	Encoder Type	Motor Type	Lead	Stroke	Applicable Controller/I/O Type	Cable Length	Options
	RCP6: Separate Controller RCP6S: Built-in Controller	WSA14R	WA	56P	24: 24mm 16: 16mm 8: 8mm 4: 4mm	50: 50mm 7 800: 800mm (50mm increments)	[RCP6] P3: PCON MCON MSEL [RCP6S] SE: SIO Type	N : None P : 1m S : 3m M : 5m X□□ : Specified Length R□□ : Robot Cable	* Body width does not include the width of the side-mounted motor. Please refer to the options table below. * Please make sure to specify either ML or MR when ordering the side-mounted motor type.

* RCP6 does not include a controller. RCP6S includes a built-in controller.

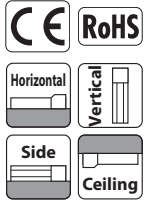

* Depending on the model, there may be some limitations to using the vertical, side, and ceiling mount positions. Please contact IAI for more information regarding mounting positions.

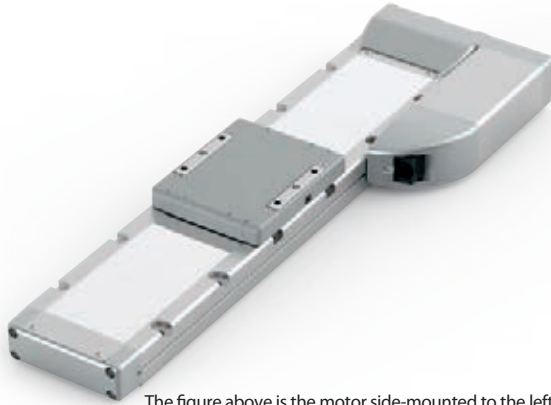

The figure above is the motor side-mounted to the left (ML).

- POINT Selection Notes**
- (1) The maximum acceleration/deceleration is 1G for horizontal, and 0.5G for vertical use.
 - (2) The actuator specification displays the payload's maximum value, but it will vary depending on the acceleration and speed. Please refer to the "Selection Guidelines" (RCP6 Tables of Payload by Speed/Acceleration) on P.115 for more details.
 - (3) When performing push-motion operation, please confirm the push force of each model by checking the "Correlation diagram of push force and current limit" on P.113.
 - (4) Depending on the ambient operational temperature, duty control is necessary for the RCP6S (built-in controller type) with lead 4/8/16. Please refer to P.130 for more information.

Correlation Diagrams of Speed and Payload

High-output enabled (*) with PCON/MCON/MSEL connected.
RCP6(S)-WSA14R Horizontal mount

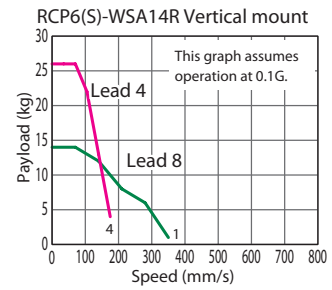
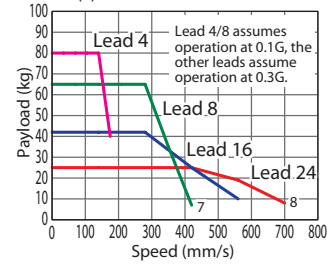

(*) For high output setting to OFF, refer to the RCP6 manual.

Actuator Specifications (*)

Lead and Payload

Model Number	Lead (mm)	Connected Controller	Max. Payload		Stroke (mm)
			Horizontal (kg)	Vertical (kg)	
RCP6(S)-WSA14R-WA-56P-24-①-②-③-④	24	High-output Enabled	25	-	50~800 (The increment of stroke is 50mm)
RCP6(S)-WSA14R-WA-56P-16-①-②-③-④	16	High-output Enabled	50	-	
RCP6(S)-WSA14R-WA-56P-8-①-②-③-④	8	High-output Enabled	65	14	
RCP6(S)-WSA14R-WA-56P-4-①-②-③-④	4	High-output Enabled	80	26	

Legend: ① Stroke ② Applicable controller/I/O type ③ Cable length ④ Options

(*) For values of disabled high output controller setting refer to the RCP6 manual.

Stroke and Max. Speed

Lead (mm)	Connected Controller	Max. Speed (Unit: mm/s)							
		50~500 (Every 50mm)	550 (mm)	600 (mm)	650 (mm)	700 (mm)	750 (mm)	800 (mm)	
24	High-output Enabled	700						665	
16	High-output Enabled	560			550	490	440		
8	High-output Enabled	420 <350>	400 <350>	350	305	270	240	215	
4	High-output Enabled	175	170	150	135	120	105		

Values in brackets < > are for vertical use.

Cable Length

Cable Type	Cable Code
Standard	P (1m)
	S (3m)
	M (5m)
Specified Length	X06 (6m) ~ X10 (10m)
	X11 (11m) ~ X15 (15m)
	X16 (16m) ~ X20 (20m)
Robot Cable	R01 (1m) ~ R03 (3m)
	R04 (4m) ~ R05 (5m)
	R06 (6m) ~ R10 (10m)
	R11 (11m) ~ R15 (15m)
	R16 (16m) ~ R20 (20m)

* Refer to P.144 for more information regarding the maintenance cables.

Options

Name	Option Code	Reference Page
Brake	B	See P.105
Cable exit direction (Outside)	CJO	See P.105
Motor side-mounted to the left	ML	See P.109
Motor side-mounted to the right	MR	See P.109
Non-motor end specification	NM	See P.110
Slider roller specification	SR	See P.111

Actuator Specifications

Item	Description
Drive system	Ball screw ø12mm, rolled C10
Positioning repeatability	±0.01mm
Lost motion	0.1mm or less
Base	Material: Aluminum with white alumite treatment
Static allowable moment	Ma: 462N·m, Mb: 462N·m, Mc: 1170N·m
Dynamic allowable moment (*1)	Ma: 122N·m, Mb: 122N·m, Mc: 308N·m
Ambient operating temp. & humidity	0~40°C, 85% RH or less (Non-condensing)

(*1) Assumes a standard rated life of 5000km. The service life will vary depending on operation and installation conditions.

- Reference for overhang load length: Ma: 550mm or less, Mb, Mc: 550mm or less

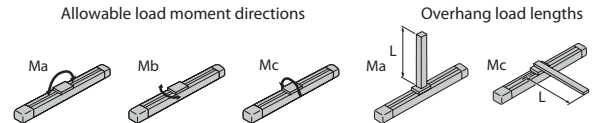

Please refer to the RoboCylinder General Catalog for more information regarding the directions of the allowable moment and overhang load length.

Dimensions

CAD drawings can be downloaded from our website.
www.robocylinder.de

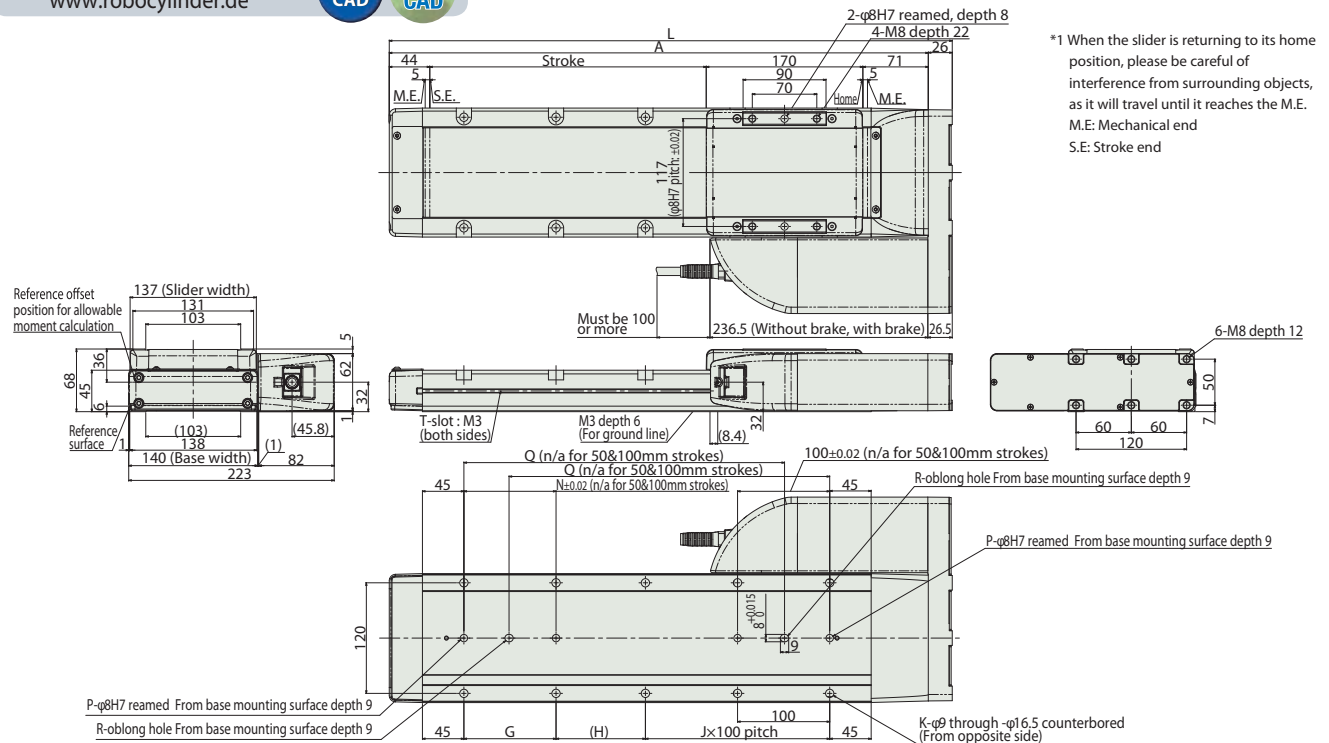

*1 When the slider is returning to its home position, please be careful of interference from surrounding objects, as it will travel until it reaches the M.E.
M.E: Mechanical end
S.E: Stroke end

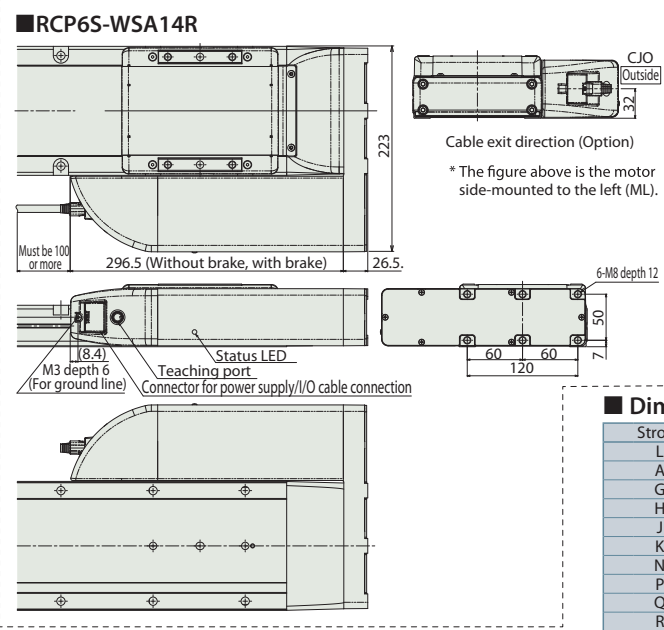

Dimensions and Mass by Stroke

Stroke	50	100	150	200	250	300	350	400	450	500	550	600	650	700	750	800
L	361	411	461	511	561	611	661	711	761	811	861	911	961	1011	1061	1111
A	335	385	435	485	535	585	635	685	735	785	835	885	935	985	1035	1085
G	-	-	100	100	100	100	100	100	100	100	100	100	100	100	100	100
H	147	197	47	97	47	97	47	97	47	97	47	97	47	97	47	97
J	0	0	1	1	2	2	3	3	4	4	5	5	6	6	7	7
K	4	4	8	8	10	10	12	12	14	14	16	16	18	18	20	20
N	-	-	100	100	100	100	100	100	100	100	100	100	100	100	100	100
P	1	1	2	2	2	2	2	2	2	2	2	2	2	2	2	2
Q	-	-	198	248	298	348	398	448	498	548	598	648	698	748	798	848
R	0	0	1	1	1	1	1	1	1	1	1	1	1	1	1	1
Mass (kg)	RCP6 w/o brake	7.3	7.8	8.2	8.7	9.2	9.6	10.1	10.6	11.1	11.5	12.0	12.5	13.0	13.4	13.9
	RCP6 w/ brake	7.4	7.9	8.3	8.8	9.3	9.8	10.2	10.7	11.2	11.7	12.1	12.6	13.1	13.6	14.0
RCP6S	w/o brake	7.4	7.9	8.4	8.9	9.3	9.8	10.3	10.8	11.2	11.7	12.2	12.7	13.1	13.6	14.1
	w/ brake	7.6	8.0	8.5	9.0	9.4	9.9	10.4	10.9	11.4	11.8	12.3	12.8	13.3	13.7	14.2

Applicable Controllers

The RCP6 series actuators can be operated by the controllers indicated below. Please select the type depending on your intended use. * Please refer to P.147 for more information about the built-in controller of RCP6S series.

Name	External view	Max. number of controlled axes	Input power	Control method				Maximum number of positioning points	Reference page
				Positioner	Pulse train	Program	Network *Option		
PCON-CB/CGB		1	DC24V	● *Option	● *Option	-	DeviceNet CC-Link EtherCAT EtherNet/IP CompoNet	512 (768 for network spec.)	Please see P.132
MCON-C/CG		4		This model is network-compatible only.				256	Please see the MCON catalog or manual.
MSEL-PC/PG		4	Single-phase 100~230VAC	-	-	●	Note: The type of compatible networks will vary depending on the controller. Please refer to reference page for more information.	30000	Please see the MSEL-PC/PG catalog or manual.

* Please select "high-output specification" as an option for the MCON. With the MCON, operation is possible only when the high-output specification is selected.

RCP6(S)-WSA16R

±10μm Standard
Simple Dust-proof
Battery-less Absolute
Motor Unit Coupled
Side-mounted Motor
Body Width 160* mm
24V Pulse Motor

Model Specification Items	Series	Type	Encoder Type	Motor Type	Lead	Stroke	Applicable Controller/I/O Type	Cable Length	Options
	RCP6: Separate Controller RCP6S: Built-in Controller	WSA16R	WA	56SP	20: 20mm 10: 10mm 5: 5mm	50: 50mm 100: 100mm 1100: 1100mm (50mm increments)	[RCP6] P4: PCON- CFB/CGFB [RCP6S] SE: SIO Type	N : None P : 1m S : 3m M : 5m X□ : Specified Length R□ : Robot Cable	* Body width does not include the width of the side-mounted motor. Please refer to the options table below. * Please make sure to specify either ML or MR when ordering the side-mounted motor type.

* RCP6 does not include a controller. RCP6S includes a built-in controller.

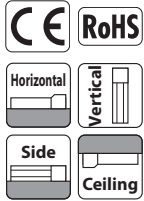

* Depending on the model, there may be some limitations to using the vertical, side, and ceiling mount positions. Please contact IAI for more information regarding mounting positions.

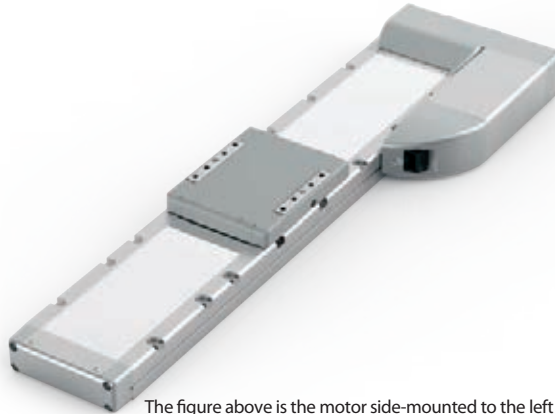

The figure above is the motor side-mounted to the left (ML).

- POINT Selection Notes**
- (1) The maximum acceleration/deceleration is 1G for horizontal, and 0.5G for vertical use.
 - (2) The actuator specification displays the payload's maximum value, but it will vary depending on the acceleration and speed. Please refer to the "Selection Guidelines" (RCP6 Tables of Payload by Speed/Acceleration) on P.115 for more details.
 - (3) When performing push-motion operation, please confirm the push force of each model by checking the "Correlation diagram of push force and current limit" on P.113.
 - (4) The service life of an actuator with lead 5 varies depending on the payload when using vertically. Please refer to P. 114 for more information.

Correlation Diagrams of Speed and Payload

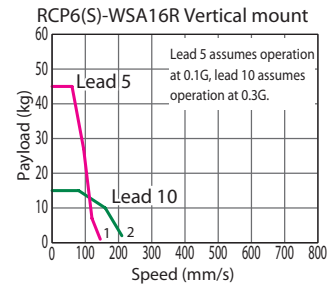
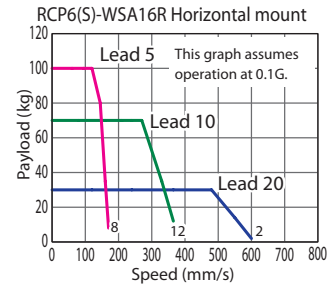

Actuator Specifications

Lead and Payload

Model Number	Lead (mm)	Max. Payload (kg)		Stroke (mm)
		Horizontal	Vertical	
RCP6(S)-WSA16R-WA-56SP-20-①-②-③-④	20	30	-	50~1100 (The increment of stroke is 50mm)
RCP6(S)-WSA16R-WA-56SP-10-①-②-③-④	10	70	15	
RCP6(S)-WSA16R-WA-56SP-5-①-②-③-④	5	100	45	

Legend: ① Stroke ② Applicable controller/I/O type ③ Cable length ④ Options

Stroke and Max. Speed

Lead (mm)	Max. Speed (mm/s)									
	50~650 (Every 50mm)	700 (mm)	750 (mm)	800 (mm)	850 (mm)	900 (mm)	950 (mm)	1000 (mm)	1050 (mm)	1100 (mm)
20	600			590	535	490	450	415		
10	365 <210>	355 <210>	320 <210>	290 <210>	265 <210>	240 <210>	225 <210>	205		
5	170 <145>	160 <145>	145	130	120	110	100			

Values in brackets < > are for vertical use.

Cable Length

Cable Type	Cable Code
Standard	P (1m)
	S (3m)
	M (5m)
Specified Length	X06 (6m) ~ X10 (10m)
	X11 (11m) ~ X15 (15m)
	X16 (16m) ~ X20 (20m)
	R01 (1m) ~ R03 (3m)
Robot Cable	R04 (4m) ~ R05 (5m)
	R06 (6m) ~ R10 (10m)
	R11 (11m) ~ R15 (15m)
	R16 (16m) ~ R20 (20m)

* Refer to P.144 for more information regarding the maintenance cables.

Options

Name	Option Code	Reference Page
Brake	B	See P.105
Cable exit direction (Outside)	CJO	See P.105
Motor side-mounted to the left	ML	See P.109
Motor side-mounted to the right	MR	See P.109
Non-motor end specification	NM	See P.110
Slider roller specification	SR	See P.111

Actuator Specifications

Item	Description
Drive system	Ball screw ø16mm, rolled C10
Positioning repeatability	±0.01mm
Lost motion	0.1mm or less
Base	Material: Aluminum with white alumite treatment
Static allowable moment	Ma: 642N·m, Mb: 642N·m, Mc: 1610N·m
Dynamic allowable moment (*1)	Ma: 161N·m, Mb: 161N·m, Mc: 404N·m
Ambient operating temp. & humidity	0~40°C, 85% RH or less (Non-condensing)

(*1) Assumes a standard rated life of 5000km. The service life will vary depending on operation and installation conditions.

- Reference for overhang load length: Ma: 650mm or less, Mb, Mc: 650mm or less

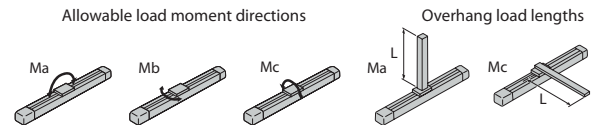

Please refer to the RoboCylinder General Catalog for more information regarding the directions of the allowable moment and overhang load length.

RCP6(S)-RA4C

Battery-less Absolute
Motor Unit Coupled
Straight Motor
Body Width 40 mm
24v Pulse Motor

Model Specification Items	Series	Type	Encoder Type	Motor Type	Lead	Stroke	Applicable Controller/I/O Type	Cable Length	Options
	RA4C	WA	35P						
	RCP6: Separate Controller RCP6S: Built-in Controller	WA: Battery-less Absolute	35P: Pulse Motor 35□ Size	16: 16mm 10: 10mm 5: 5mm 2.5: 2.5mm	50: 50mm 200: 200mm (50mm increments)	[RCP6] P3: PCON MCON MSEL [RCP6S] SE: SIO Type	N : None P : 1m S : 3m M : 5m X□□ : Specified Length R□□ : Robot Cable	Please refer to the options table below.	

* RCP6 does not include a controller. RCP6S includes a built-in controller.

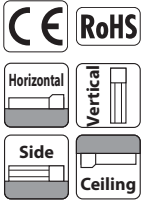

*Depending on the model, there may be some limitations to using the vertical, side, and ceiling mount positions. Please contact IAI for more information regarding mounting positions.

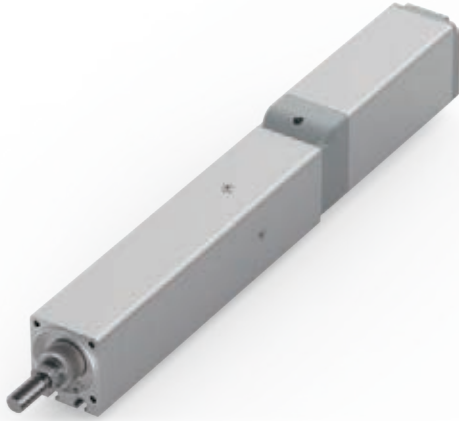

- POINT Selection Notes**
- (1) The maximum acceleration/deceleration is 1G for horizontal, and 0.5G for vertical use.
 - (2) The actuator specification displays the payload's maximum value, but it will vary depending on the acceleration and speed. Please refer to the "Selection Guidelines" (RCP6 Tables of Payload by Speed/Acceleration) on P.115 for more details.
 - (3) The value of the horizontal payload assumes that there is an external guide. Please be aware that the anti-rotation stopper can be damaged when an external force is applied to the rod from any direction other than the moving direction.
 - (4) When performing push-motion operation, please confirm the push force of each model by checking the "Correlation diagram of push force and current limit" on P.113.

Correlation Diagrams of Speed and Payload

High-output enabled (*) with PCON/MCON/MSEL connected.
RCP6(S)-RA4C Horizontal mount

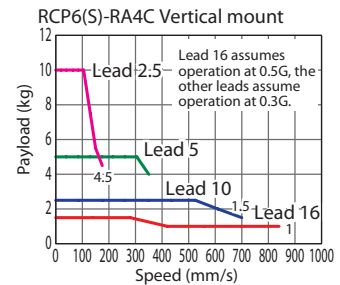
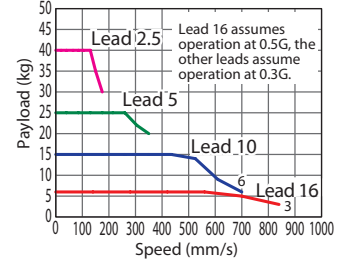

(*) For high output setting to OFF refer to the RCP6 manual.

Actuator Specifications (*)

(*) For values of disabled high output controller setting refer to the RCP6 manual.

Lead and Payload

Model Number	Lead (mm)	Connected Controller	Max. Payload		Stroke (mm)
			Horizontal (kg)	Vertical (kg)	
RCP6(S)-RA4C-WA-35P-16-①-②-③-④	16	High-output Enabled	6	1.5	50~200 (The increment of stroke is 50mm)
RCP6(S)-RA4C-WA-35P-10-①-②-③-④	10	High-output Enabled	15	2.5	
RCP6(S)-RA4C-WA-35P-5-①-②-③-④	5	High-output Enabled	28	5	
RCP6(S)-RA4C-WA-35P-2.5-①-②-③-④	2.5	High-output Enabled	40	10	

Stroke and Max. Speed

(Unit: mm/s)

Lead (mm)	Connected Controller	50~200 (Every 50mm)
16	High-output Enabled	840
10	High-output Enabled	700
5	High-output Enabled	350
2.5	High-output Enabled	175

Legend: ① Stroke ② Applicable controller/I/O type ③ Cable length ④ Options

Cable Length

Cable Type	Cable Code
Standard	P (1m)
	S (3m)
	M (5m)
Specified Length	X06 (6m) ~ X10 (10m)
	X11 (11m) ~ X15 (15m)
	X16 (16m) ~ X20 (20m)
	R01 (1m) ~ R03 (3m)
Robot Cable	R04 (4m) ~ R05 (5m)
	R06 (6m) ~ R10 (10m)
	R11 (11m) ~ R15 (15m)
	R16 (16m) ~ R20 (20m)

* Refer to P.144 for more information regarding the maintenance cables.

Options

Name	Option Code	Reference Page
Brake	B	See P.105
Cable exit direction (Top)	CJT	See P.105
Cable exit direction (Right)	CJR	See P.105
Cable exit direction (Left)	CJL	See P.105
Cable exit direction (Bottom)	CJB	See P.105
Flange	FL	See P.106
Foot bracket	FT	See P.107
Tip adapter (Internal thread)	NFA	See P.109
Non-motor end specification	NM	See P.110
T-slot nut bar	NTB	See P.110

Actuator Specifications

Item	Description
Drive system	Ball screw ø8mm, rolled C10
Positioning repeatability	±0.01mm
Lost motion	0.1mm or less
Rod	ø20mm Material: Aluminum with hard alumite treatment
Static allowable torque on rod tip	To: 1.0N·m
Max. angular displacement on rod tip (*1)	θ: ±1.0 deg.
Ambient operating temp. & humidity	0~40°C, 85% RH or less (Non-condensing)

(*1) This is the displacement angle of the rod tip (initial reference value) when the rod is fully retracted and the static allowable torque is applied at the rod tip.

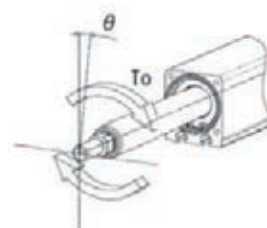

RCP6(S)-RA6C

Battery-less Absolute
Motor Unit Coupled
Straight Motor
Body Width 58 mm
24v Pulse Motor

Model Specification Items	Series	Type	Encoder Type	Motor Type	Lead	Stroke	Applicable Controller/I/O Type	Cable Length	Options
	RA6C	WA	42P						
	RCP6: Separate Controller RCP6S: Built-in Controller	WA: Battery-less Absolute	42P: Pulse Motor 42□ Size	20: 20mm 12: 12mm 6: 6mm 3: 3mm	50: 50mm 300: 300mm (50mm increments)	[RCP6] P3: PCON MCON MSEL [RCP6S] SE: SIO Type	N : None P : 1m S : 3m M : 5m X□□ : Specified Length R□□ : Robot Cable	Please refer to the options table below.	

* RCP6 does not include a controller. RCP6S includes a built-in controller.

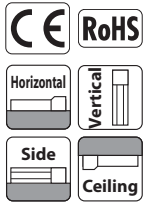

*Depending on the model, there may be some limitations to using the vertical, side, and ceiling mount positions. Please contact IAI for more information regarding mounting positions.

- POINT Selection Notes**
- (1) The maximum acceleration/deceleration is 1G for horizontal, and 0.5G for vertical use.
 - (2) The actuator specification displays the payload's maximum value, but it will vary depending on the acceleration and speed. Please refer to the "Selection Guidelines" (RCP6 Tables of Payload by Speed/Acceleration) on P.115 for more details.
 - (3) The value of the horizontal payload assumes that there is an external guide. Please be aware that the anti-rotation stopper can be damaged when an external force is applied to the rod from any direction other than the moving direction.
 - (4) When performing push-motion operation, please confirm the push force of each model by checking the "Correlation diagram of push force and current limit" on P.113.
 - (5) Depending on the ambient operational temperature, duty control is necessary for the RCP6S (built-in controller type) with lead 3/6. Please refer to P.130 for more information.

Correlation Diagrams of Speed and Payload

High-output enabled (*) with PCON/MCON/MSEL connected. RCP6(S)-RA6C Horizontal mount

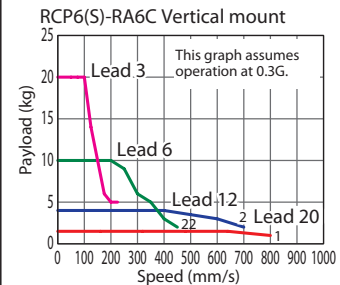
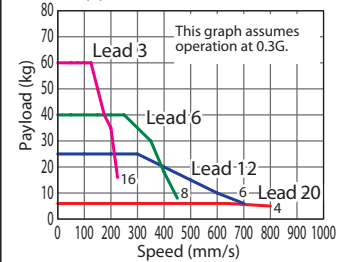

(*) For high output setting to OFF, refer to the RCP6 manual.

Actuator Specifications (*)

(*) For values of disabled high output controller setting refer to the RCP6 manual.

Lead and Payload

Model Number	Lead (mm)	Connected Controller	Max. Payload		Stroke (mm)
			Horizontal (kg)	Vertical (kg)	
RCP6(S)-RA6C-WA-42P-20-①-②-③-④	20	High-output Enabled	6	1.5	50~300 (The increment of stroke is 50mm)
RCP6(S)-RA6C-WA-42P-12-①-②-③-④	12	High-output Enabled	25	4	
RCP6(S)-RA6C-WA-42P-6-①-②-③-④	6	High-output Enabled	40	10	
RCP6(S)-RA6C-WA-42P-3-①-②-③-④	3	High-output Enabled	60	20	

Stroke and Max. Speed

(Unit: mm/s)

Lead (mm)	Connected Controller	50~300 (Every 50mm)
20	High-output Enabled	800
12	High-output Enabled	700
6	High-output Enabled	450
3	High-output Enabled	225

Legend: ① Stroke ② Applicable controller/I/O type ③ Cable length ④ Options

Cable Length

Cable Type	Cable Code
Standard	P (1m)
	S (3m)
	M (5m)
Specified Length	X06 (6m) ~ X10 (10m)
	X11 (11m) ~ X15 (15m)
	X16 (16m) ~ X20 (20m)
	R01 (1m) ~ R03 (3m)
Robot Cable	R04 (4m) ~ R05 (5m)
	R06 (6m) ~ R10 (10m)
	R11 (11m) ~ R15 (15m)
	R16 (16m) ~ R20 (20m)

* Refer to P.144 for more information regarding the maintenance cables.

Options

Name	Option Code	Reference Page
Brake	B	See P.105
Cable exit direction (Top)	CJT	See P.105
Cable exit direction (Right)	CJR	See P.105
Cable exit direction (Left)	CJL	See P.105
Cable exit direction (Bottom)	CJB	See P.105
Flange	FL	See P.106
Foot bracket	FT	See P.107
Tip adapter (Internal thread)	NFA	See P.109
Non-motor end specification	NM	See P.110
T-slot nut bar	NTB	See P.110

Actuator Specifications

Item	Description
Drive system	Ball screw ø10mm, rolled C10
Positioning repeatability	±0.01mm
Lost motion	0.1mm or less
Rod	ø25mm Material: Aluminum with hard alumite treatment
Static allowable torque on rod tip	To: 1.5N·m
Max. angular displacement on rod tip (*1)	θ: ±1.0 deg.
Ambient operating temp. & humidity	0~40°C, 85% RH or less (Non-condensing)

(*1) This is the displacement angle of the rod tip (initial reference value) when the rod is fully retracted and the static allowable torque is applied at the rod tip.

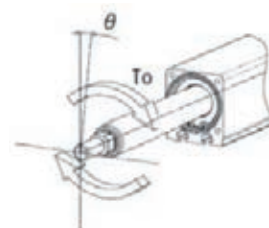

Dimensions

CAD drawings can be downloaded from our website.
www.robocylinder.de



- *1 When the rod is returning to its home position, please be careful of interference from surrounding objects, as it will travel until it reaches the M.E.
- M.E: Mechanical end S.E: Stroke end
- *2 The direction of width across flats varies depending on the product.

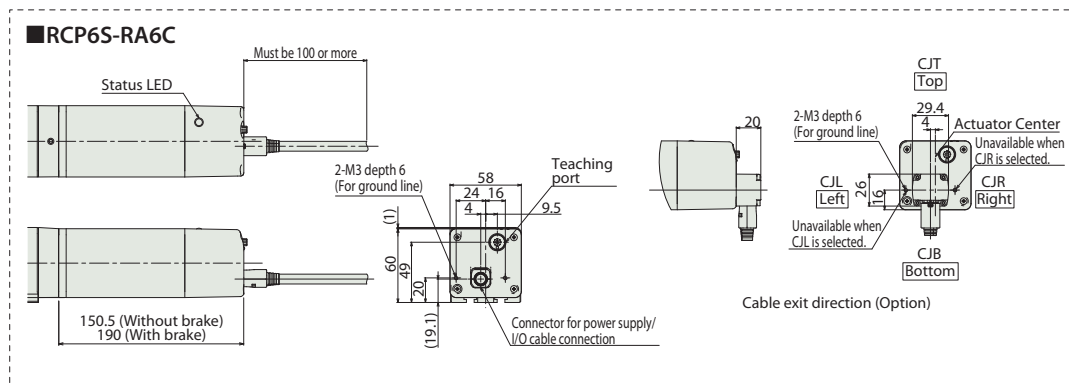
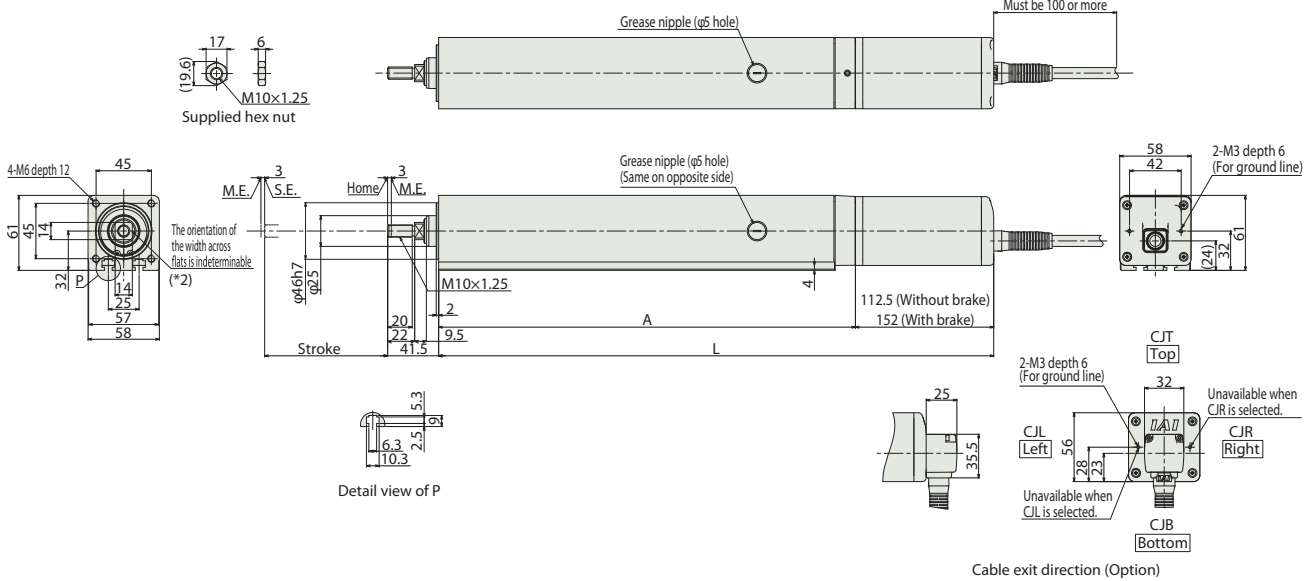

Dimensions and Mass by Stroke

L	Stroke	50	100	150	200	250	300	
		RCP6	w/o brake 301.5	351.5	401.5	451.5	501.5	551.5
A	RCP6S	w/o brake 339.5	389.5	439.5	489.5	539.5	589.5	
		w/ brake 379	429	479	529	579	629	
Mass (kg)	RCP6	w/o brake	2.5	2.9	3.3	3.6	4.0	4.4
		w/ brake	2.7	3.1	3.5	3.9	4.3	4.7
	RCP6S	w/o brake	2.6	3.0	3.4	3.8	4.2	4.6
		w/ brake	2.9	3.2	3.6	4.0	4.4	4.8

Applicable Controllers

The RCP6 series actuators can be operated by the controllers indicated below. Please select the type depending on your intended use. * Please refer to P.147 for more information about the built-in controller of RCP6S series.

Name	External view	Max. number of controlled axes	Input power	Control method				Maximum number of positioning points	Reference page
				Positioner	Pulse train	Program	Network *Option		
PCON-CB/CGB		1	DC24V	● *Option	● *Option	-		512 (768 for network spec.)	Please see P.132
MCON-C/CG		4		This model is network-compatible only.				256	Please see the MCON catalog or manual.
MSEL-PC/PG		4	Single-phase 100~230VAC	-	-	●	Note: The type of compatible networks will vary depending on the controller. Please refer to reference page for more information.	30000	Please see the MSEL-PC/PG catalog or manual.

* Please select "high-output specification" as an option for the MCON. With the MCON, operation is possible only when the high-output specification is selected.

RCP6(S)-RA7C

Battery-less Absolute
Motor Unit Coupled
Straight Motor
Body Width 70 mm
24v Pulse Motor

Model Specification Items	Series	Type	Encoder Type	Motor Type	Lead	Stroke	Applicable Controller/I/O Type	Cable Length	Options
	RA7C	WA	56P						
	RCP6: Separate Controller RCP6S: Built-in Controller	WA: Battery-less Absolute	56P: Pulse Motor 56□ Size	24: 24mm 16: 16mm 8: 8mm 4: 4mm	50: 50mm 300: 300mm (50mm increments)	[RCP6] P3: PCON MCON MSEL [RCP6S] SE: SIO Type	N : None P : 1m S : 3m M : 5m X□ : Specified Length R□ : Robot Cable	Please refer to the options table below.	

* RCP6 does not include a controller. RCP6S includes a built-in controller.

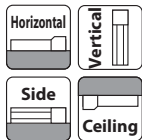

*Depending on the model, there may be some limitations to using the vertical, side, and ceiling mount positions. Please contact IAI for more information regarding mounting positions.



- (1) The maximum acceleration/deceleration is 1G for horizontal, and 0.5G for vertical use.
- (2) The actuator specification displays the payload's maximum value, but it will vary depending on the acceleration and speed. Please refer to the "Selection Guidelines" (RCP6 Tables of Payload by Speed/Acceleration) on P.115 for more details.
- (3) The value of the horizontal payload assumes that there is an external guide. Please be aware that the anti-rotation stopper can be damaged when an external force is applied to the rod from any direction other than the moving direction.
- (4) When performing push-motion operation, please confirm the push force of each model by checking the "Correlation diagram of push force and current limit" on P.113.
- (5) Depending on the ambient operational temperature, duty control is necessary for the RCP6S (built-in controller type) with lead 4/8/16. Please refer to P.130 for more information.

Correlation Diagrams of Speed and Payload

High-output enabled (*) with PCON/MCON/MSEL connected. RCP6(S)-RA7C Horizontal mount

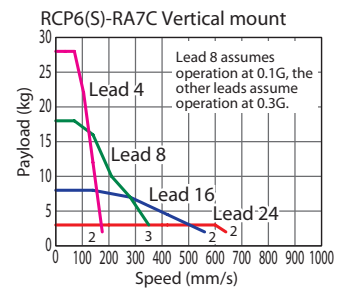
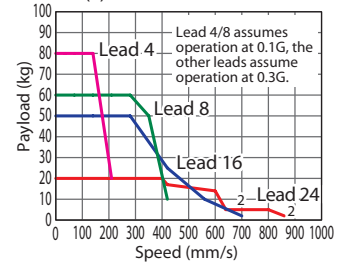

(*) For high output setting to OFF, refer to the RCP6 manual.

Actuator Specifications (*)

(*) For values of disabled high output controller setting refer to the RCP6 manual.

Lead and Payload

Model Number	Lead (mm)	Connected Controller	Max. Payload		Stroke (mm)
			Horizontal (kg)	Vertical (kg)	
RCP6(S)-RA7C-WA-56P-24-①-②-③-④	24	High-output Enabled	20	3	50~300 (The increment of stroke is 50mm)
RCP6(S)-RA7C-WA-56P-16-①-②-③-④	16	High-output Enabled	50	8	
RCP6(S)-RA7C-WA-56P-8-①-②-③-④	8	High-output Enabled	60	18	
RCP6(S)-RA7C-WA-56P-4-①-②-③-④	4	High-output Enabled	80	28	

Stroke and Max. Speed

(Unit: mm/s)

Lead (mm)	Connected Controller	50~300 (Every 50mm)
24	High-output Enabled	860 <640>
16	High-output Enabled	700 <560>
8	High-output Enabled	420 <350>
4	High-output Enabled	210 <175>

Legend: ① Stroke ② Applicable controller/I/O type ③ Cable length ④ Options

Values in brackets < > are for vertical use.

Cable Length

Cable Type	Cable Code
Standard	P (1m)
	S (3m)
	M (5m)
Specified Length	X06 (6m) ~ X10 (10m)
	X11 (11m) ~ X15 (15m)
	X16 (16m) ~ X20 (20m)
Robot Cable	R01 (1m) ~ R03 (3m)
	R04 (4m) ~ R05 (5m)
	R06 (6m) ~ R10 (10m)
	R11 (11m) ~ R15 (15m)
	R16 (16m) ~ R20 (20m)
	R20 (20m)

* Refer to P.144 for more information regarding the maintenance cables.

Options

Name	Option Code	Reference Page
Brake	B	See P.105
Cable exit direction (Top)	CJT	See P.105
Cable exit direction (Right)	CJR	See P.105
Cable exit direction (Left)	CJL	See P.105
Cable exit direction (Bottom)	CJB	See P.105
Flange	FL	See P.106
Foot bracket	FT	See P.107
Tip adapter (Internal thread)	NFA	See P.109
Non-motor end specification	NM	See P.110
T-slot nut bar	NTB	See P.110

Actuator Specifications

Item	Description
Drive system	Ball screw ø12mm, rolled C10
Positioning repeatability	±0.01mm
Lost motion	0.1mm or less
Rod	ø30mm Material: Aluminum with hard alumite treatment
Static allowable torque on rod tip	To: 2.5N·m
Max. angular displacement on rod tip (*1)	θ: ±0.8 deg.
Ambient operating temp. & humidity	0~40°C, 85% RH or less (Non-condensing)

(*1) This is the displacement angle of the rod tip (initial reference value) when the rod is fully retracted and the static allowable torque is applied at the rod tip.

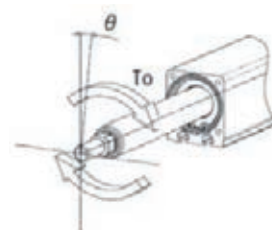

Dimensions

CAD drawings can be downloaded from our website.
www.robocylinder.de



*1 When the rod is returning to its home position, please be careful of interference from surrounding objects, as it will travel until it reaches the M.E.
 M.E: Mechanical end S.E: Stroke end
 *2 The direction of width across flats varies depending on the product.

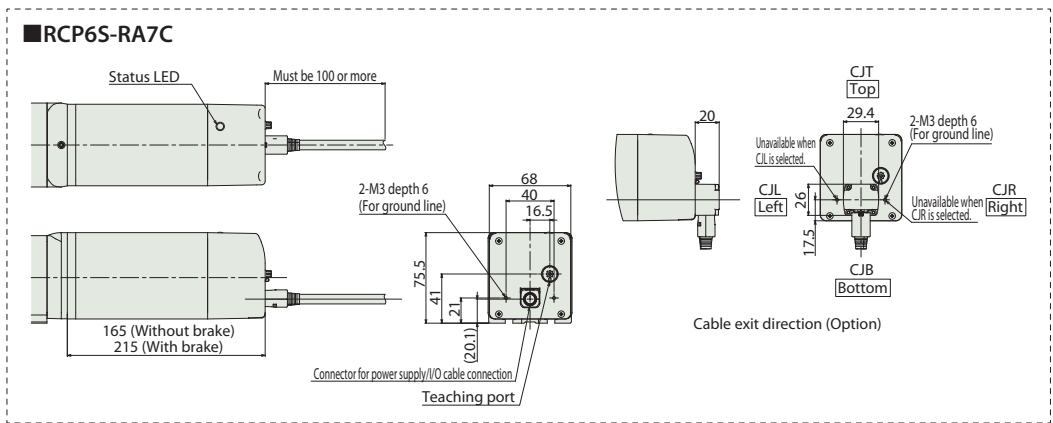
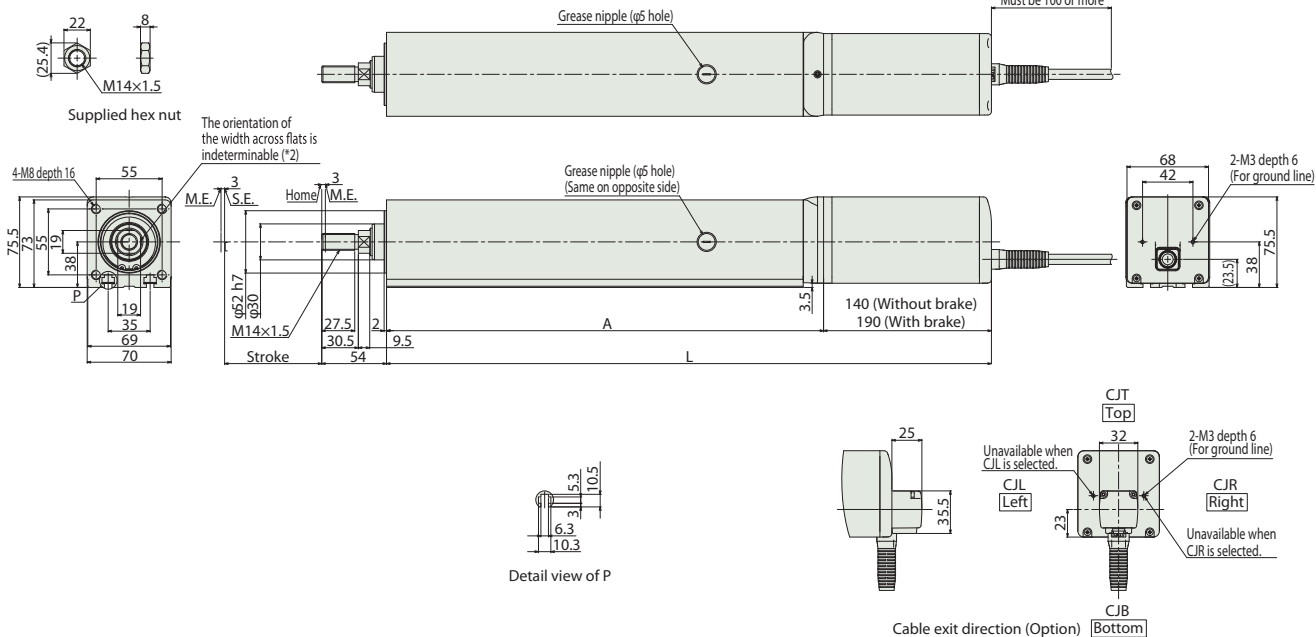

Dimensions and Mass by Stroke

L	Stroke	50	100	150	200	250	300
		RCP6	w/o brake 354.5	404.5	454.5	504.5	554.5
RCP6S	w/o brake	379.5	429.5	479.5	529.5	579.5	629.5
	w/ brake	429.5	479.5	529.5	579.5	629.5	679.5
A		214.5	264.5	314.5	364.5	414.5	464.5
Mass (kg)	RCP6	4.5	5.1	5.6	6.2	6.7	7.3
	RCP6S	4.7	5.2	5.8	6.3	6.9	7.5
		5.1	5.7	6.2	6.8	7.3	7.9

Applicable Controllers

The RCP6 series actuators can be operated by the controllers indicated below. Please select the type depending on your intended use. * Please refer to P.147 for more information about the built-in controller of RCP6S series.

Name	External view	Max. number of controlled axes	Input power	Control method				Maximum number of positioning points	Reference page
				Positioner	Pulse train	Program	Network *Option		
PCON-CB/CGB		1	DC24V	● *Option	● *Option	-	 	512 (768 for network spec.)	Please see P.132
MCON-C/CG		4		This model is network-compatible only.					
MSEL-PC/PG		4	Single-phase 100~230VAC	-	-	●		30000	Please see the MSEL-PC/PG catalog or manual.

* Please select "high-output specification" as an option for the MCON. With the MCON, operation is possible only when the high-output specification is selected.

RCP6(S)-RA8C

Battery-less Absolute
Motor Unit Coupled
Straight Motor
Body Width 85 mm
24v Pulse Motor

Model Specification Items	Series	Type	Encoder Type	Motor Type	Lead	Stroke	Applicable Controller/I/O Type	Cable Length	Options
	RA8C	WA	60P						
	RCP6: Separate Controller RCP6S: Built-in Controller	WA: Battery-less Absolute	60P: Pulse Motor 60□ Size	20: 20mm 10: 10mm 5: 5mm	50: 50mm 300: 300mm (50mm increments)	[RCP6] P4: PCON- CFB/CGFB [RCP6S] SE: SIO Type	N : None P : 1m S : 3m M : 5m X□ : Specified Length R□ : Robot Cable	Please refer to the options table below.	

* RCP6 does not include a controller. RCP6S includes a built-in controller.

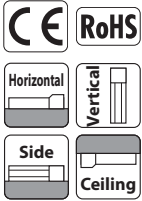

*Depending on the model, there may be some limitations to using the vertical, side, and ceiling mount positions. Please contact IAI for more information regarding mounting positions.



- (1) The maximum acceleration/deceleration is 0.1G for lead 5 and 0.2G for lead 10/20.
- (2) The actuator specification displays the payload's maximum value, but it will vary depending on the acceleration and speed. Please refer to the "Selection Guidelines" (RCP6 Tables of Payload by Speed/Acceleration) on P.115 for more details.
- (3) The value of the horizontal payload assumes that there is an external guide. Please be aware that the anti-rotation stopper can be damaged when an external force is applied to the rod from any direction other than the moving direction.
- (4) When performing push-motion operation, please confirm the push force of each model by checking the "Correlation diagram of push force and current limit" on P.113.
- (5) For RCP6S (built-in controller type), please limit the duty cycle to 70% or less.
- (6) The service life of an actuator varies depending on the payload when using vertically. Please refer to P. 114 for more information.

Correlation Diagrams of Speed and Payload

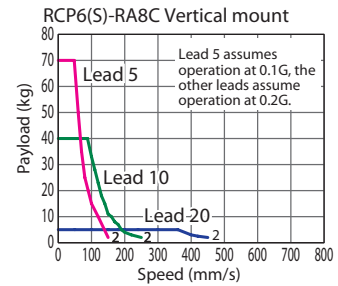
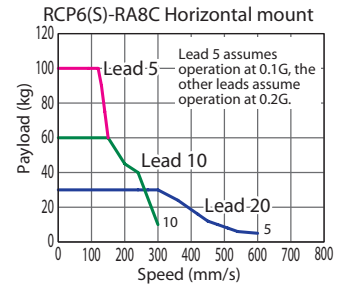

Actuator Specifications

Lead and Payload

Model Number	Lead (mm)	Max. Payload (kg)		Stroke (mm)
		Horizontal (kg)	Vertical (kg)	
RCP6(S)-RA8C-WA-60P-20-①-②-③-④	20	30	5	50~300 (The increment of stroke is 50mm)
RCP6(S)-RA8C-WA-60P-10-①-②-③-④	10	60	40	
RCP6(S)-RA8C-WA-60P-5-①-②-③-④	5	100	70	

Stroke and Max. Speed

Lead (mm)	50~300 (Every 50mm)	
	Horizontal (mm)	Vertical (mm)
20	600	<450>
10	300	<250>
5	150	

Legend: ① Stroke ② Applicable controller/I/O type ③ Cable length ④ Options

Values in brackets < > are for vertical use.

Cable Length

Cable Type	Cable Code
Standard	P (1m)
	S (3m)
	M (5m)
Specified Length	X06 (6m) ~ X10 (10m)
	X11 (11m) ~ X15 (15m)
	X16 (16m) ~ X20 (20m)
	R01 (1m) ~ R03 (3m)
Robot Cable	R04 (4m) ~ R05 (5m)
	R06 (6m) ~ R10 (10m)
	R11 (11m) ~ R15 (15m)
	R16 (16m) ~ R20 (20m)
	R07 (7m) ~ R09 (9m)
	R12 (12m) ~ R14 (14m)

* Refer to P.144 for more information regarding the maintenance cables.

Options

Name	Option Code	Reference Page
Brake	B	See P.105
Cable exit direction (Top)	CJT	See P.105
Cable exit direction (Right)	CJR	See P.105
Cable exit direction (Left)	CJL	See P.105
Cable exit direction (Bottom)	CJB	See P.105
Flange	FL	See P.106
Foot bracket	FT	See P.107
Tip adapter (Internal thread)	NFA	See P.109
Non-motor end specification	NM	See P.110
T-slot nut bar	NTB	See P.110

Actuator Specifications

Item	Description
Drive system	Ball screw ø16mm, rolled C10
Positioning repeatability	±0.01mm
Lost motion	0.1mm or less
Rod	ø40mm Material: Aluminum with hard alumite treatment
Static allowable torque on rod tip	To: 5.0N·m
Max. angular displacement on rod tip (*1)	θ: ±0.8 deg.
Ambient operating temp. & humidity	0~40°C, 85% RH or less (Non-condensing)

(*1) This is the displacement angle of the rod tip (initial reference value) when the rod is fully retracted and the static allowable torque is applied at the rod tip.

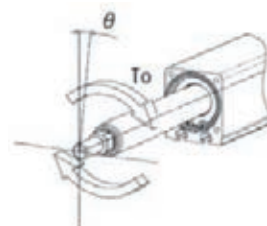

Dimensions

CAD drawings can be downloaded from our website.
www.robocylinder.de



*1 When the rod is returning to its home position, please be careful of interference from surrounding objects, as it will travel until it reaches the M.E.
M.E: Mechanical end S.E: Stroke end
*2 The direction of width across flats varies depending on the product.

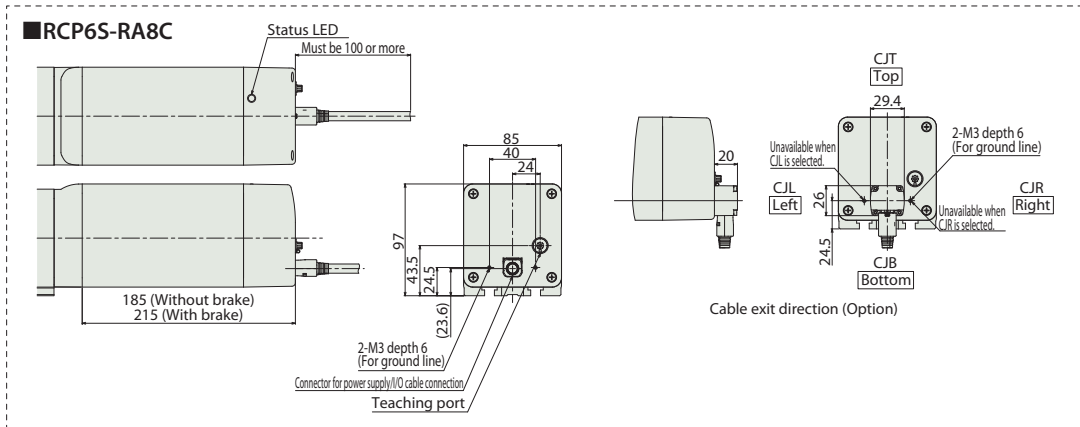
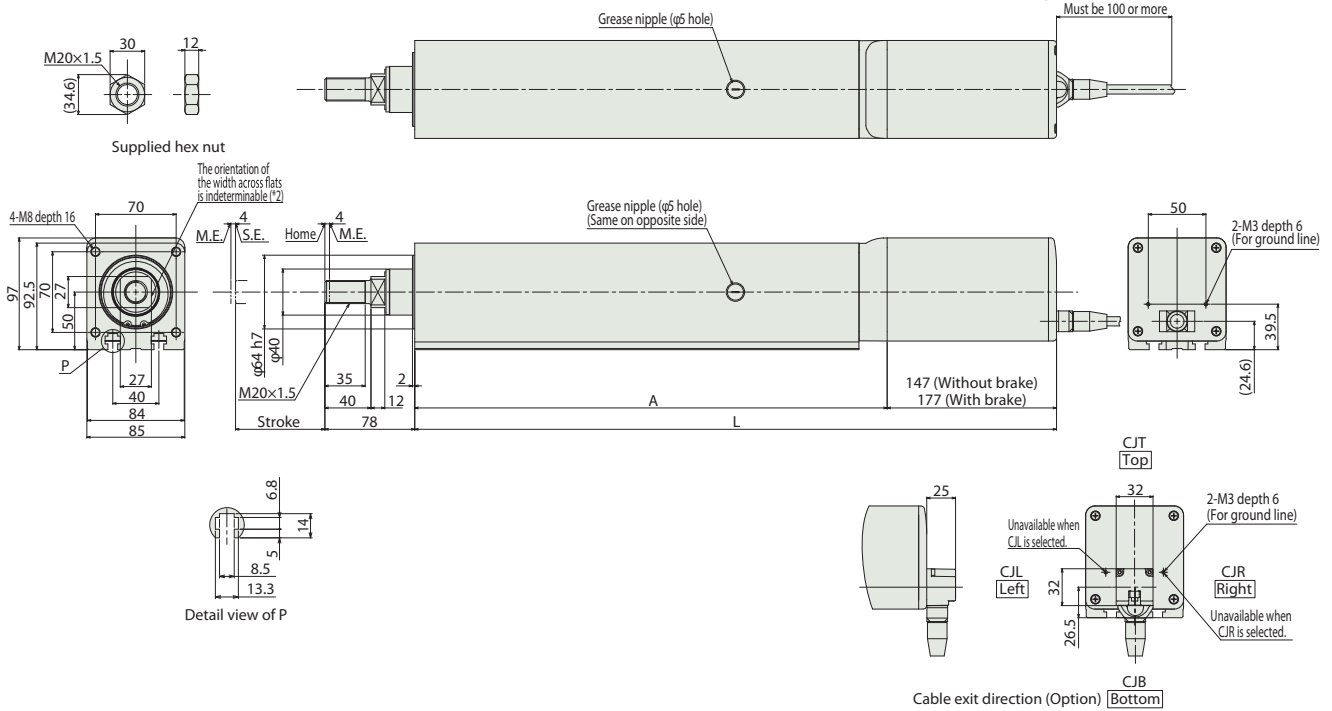

Dimensions and Mass by Stroke

		Stroke	50	100	150	200	250	300
L	RCP6	w/o brake	407	457	507	557	607	657
		w/ brake	437	487	537	587	637	687
	RCP6S	w/o brake	445	495	545	595	645	695
		w/ brake	475	525	575	625	675	725
A			260	310	360	410	460	510
Mass (kg)	RCP6	w/o brake	7.8	8.6	9.5	10.3	11.1	11.9
		w/ brake	8.4	9.2	10.0	10.9	11.7	12.5
	RCP6S	w/o brake	8.1	9.0	9.8	10.6	11.4	12.3
		w/ brake	8.7	9.5	10.4	11.2	12.0	12.8

Applicable Controllers

The RCP6 series actuators can be operated by the controllers indicated below. Please select the type depending on your intended use. * Please refer to P.147 for more information about the built-in controller of RCP6S series.

Name	External view	Max. number of controlled axes	Input power	Positioner			Control method			Maximum number of positioning points	Reference page
				Positioner	Pulse train	Program	Network *Option				
PCON-CFB/CGFB		1	DC24V	● *Option	● *Option	-	DeviceNet	CompoNet	EtherNet/IP	512 (768 for network spec.)	Please see P.132

RCP6(S)-RA4R

Battery-less Absolute
Motor Unit Coupled
Side-mounted Motor
Body Width 40* mm
24v Pulse Motor

Model Specification Items	Series	Type	Encoder Type	Motor Type	Lead	Stroke	Applicable Controller/I/O Type	Cable Length	Options
	RA4R	WA	35P						
	RCP6: Separate Controller RCP6S: Built-in Controller	WA: Battery-less Absolute	35P: Pulse Motor 35□ Size	16: 16mm 10: 10mm 5: 5mm 2.5: 2.5mm	50: 50mm 200: 200mm (50mm increments)	[RCP6] P3: PCON MCON MSEL [RCP6S] SE: SIO Type	N : None P : 1m S : 3m M : 5m X□□ : Specified Length R□□ : Robot Cable	Please refer to the options table below. *Please make sure to specify ML, MR or MT when ordering the side-mounted motor type.	

* RCP6 does not include a controller. RCP6S includes a built-in controller.

* Body width does not include the width of the side-mounted motor.

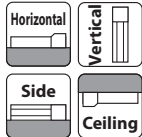

*Depending on the model, there may be some limitations to using the vertical, side, and ceiling mount positions. Please contact IAI for more information regarding mounting positions.



The figure above is the motor side-mounted to the left (ML).

POINT Selection Notes

- The maximum acceleration/deceleration is 1G for horizontal, and 0.5G for vertical use.
- The actuator specification displays the payload's maximum value, but it will vary depending on the acceleration and speed. Please refer to the "Selection Guidelines" (RCP6 Tables of Payload by Speed/Acceleration) on P.115 for more details.
- The value of the horizontal payload assumes that there is an external guide. Please be aware that the anti-rotation stopper can be damaged when an external force is applied to the rod from any direction other than the moving direction.
- When performing push-motion operation, please confirm the push force of each model by checking the "Correlation diagram of push force and current limit" on P.113.

Correlation Diagrams of Speed and Payload

High-output enabled (*) with PCON/MCON/MSEL connected.
RCP6(S)-RA4R Horizontal mount

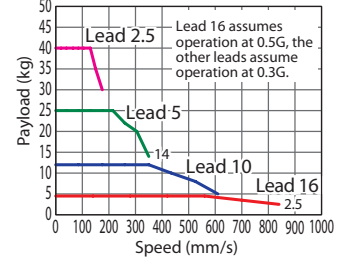

RCP6(S)-RA4R Vertical mount

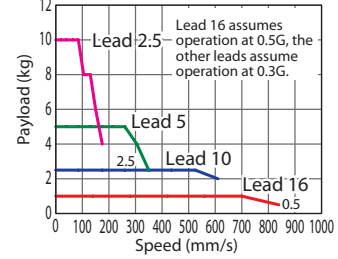

(*) For high output setting to OFF, refer to the RCP6 manual.

Actuator Specifications (*)

(*) For values of disabled high output controller setting refer to the RCP6 manual.

Lead and Payload

Model Number	Lead (mm)	Connected Controller	Max. Payload		Stroke (mm)
			Horizontal (kg)	Vertical (kg)	
RCP6(S)-RA4R-WA-35P-16-①-②-③-④	16	High-output Enabled	5	1	50~200 (The increment of stroke is 50mm)
RCP6(S)-RA4R-WA-35P-10-①-②-③-④	10	High-output Enabled	12	2.5	
RCP6(S)-RA4R-WA-35P-5-①-②-③-④	5	High-output Enabled	25	5	
RCP6(S)-RA4R-WA-35P-2.5-①-②-③-④	2.5	High-output Enabled	40	10	

Stroke and Max. Speed

(Unit: mm/s)

Lead (mm)	Connected Controller	50~200 (Every 50mm)
16	High-output Enabled	840
10	High-output Enabled	610
5	High-output Enabled	350
2.5	High-output Enabled	175

Legend: ① Stroke ② Applicable controller/I/O type ③ Cable length ④ Options

Cable Length

Cable Type	Cable Code
Standard	P (1m)
	S (3m)
	M (5m)
Specified Length	X06 (6m) ~ X10 (10m)
	X11 (11m) ~ X15 (15m)
	X16 (16m) ~ X20 (20m)
	R01 (1m) ~ R03 (3m)
Robot Cable	R04 (4m) ~ R05 (5m)
	R06 (6m) ~ R10 (10m)
	R11 (11m) ~ R15 (15m)
	R16 (16m) ~ R20 (20m)
	R16 (16m) ~ R20 (20m)

* Refer to P.144 for more information regarding the maintenance cables.

Options

Name	Option Code	Reference Page
Brake	B	See P.105
Cable exit direction (Outside)	CJO	See P.105
Flange	FL	See P.106
Foot bracket	FT	See P.107
Motor side-mounted to the left	ML	See P.109
Motor side-mounted to the right	MR	See P.109
Motor side-mounted to the top	MT	See P.109
Tip adapter (Internal thread)	NFA	See P.109
Non-motor end specification	NM	See P.110
T-slot nut bar	NTB	See P.110

Actuator Specifications

Item	Description
Drive system	Ball screw ø8mm, rolled C10
Positioning repeatability	±0.01mm
Lost motion	0.1mm or less
Rod	ø20mm Material: Aluminum with hard alumite treatment
Static allowable torque on rod tip	To: 1.0N·m
Max. angular displacement on rod tip (*1)	θ: ±1.0 deg.
Ambient operating temp. & humidity	0~40°C, 85% RH or less (Non-condensing)

(*1) This is the displacement angle of the rod tip (initial reference value) when the rod is fully retracted and the static allowable torque is applied at the rod tip.

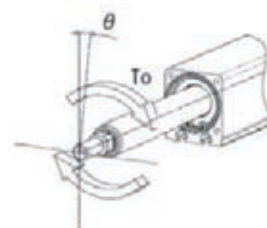

Dimensions

CAD drawings can be downloaded from our website.
www.robocylinder.de



*1 When the rod is returning to its home position, please be careful of interference from surrounding objects, as it will travel until it reaches the M.E.
M.E: Mechanical end S.E: Stroke end
*2 The direction of width across flats varies depending on the product.
Grease nipple (ø2.5 hole)
(Top and side)

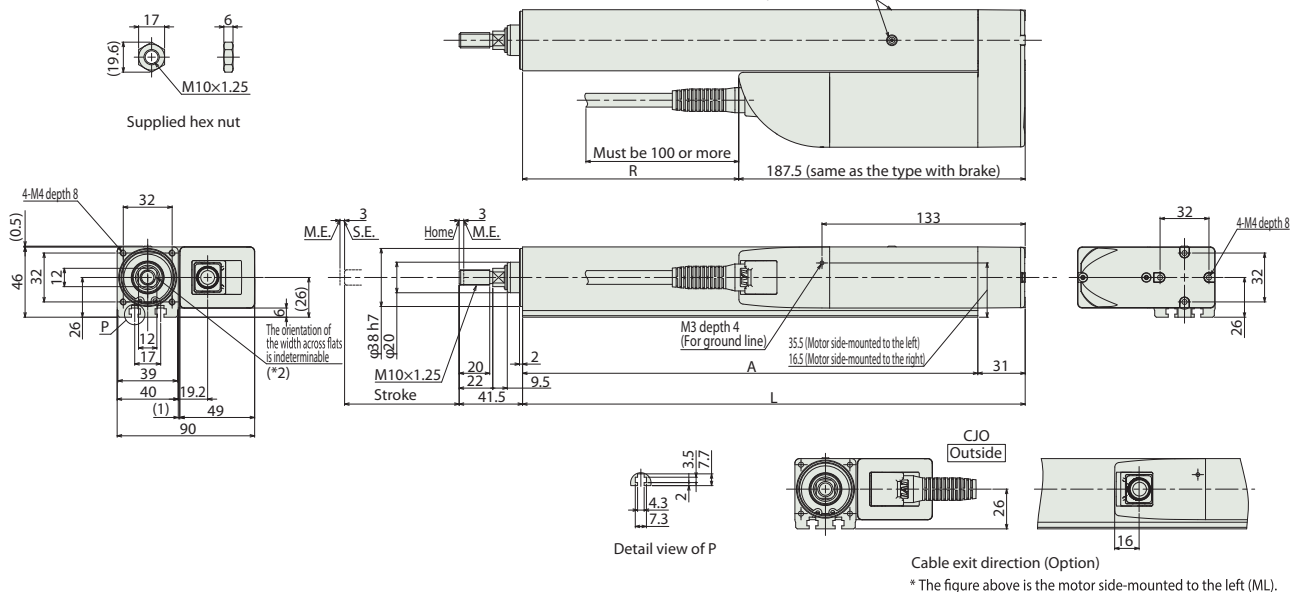

Cable exit direction (Option)
* The figure above is the motor side-mounted to the left (ML).

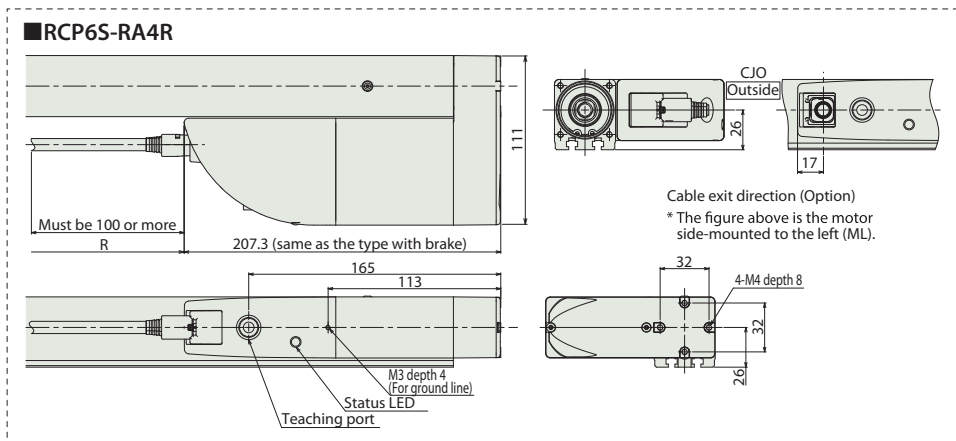

Note:
* If the length for R is negative in the table below, the length of the actuator body is shorter than the motor unit.

Dimensions and Mass by Stroke

Stroke	50	100	150	200		
L	179	229	279	329		
A	148	198	248	298		
R	RCP6	-8.5	41.5	91.5	141.5	
	RCP6S	-28.3	21.7	71.7	121.7	
Mass (kg)	RCP6	w/o brake	1.5	1.7	1.9	2.1
		w/ brake	1.6	1.8	2	2.2
	RCP6S	w/o brake	1.6	1.8	2	2.2
		w/ brake	1.7	1.9	2.1	2.3

Applicable Controllers

The RCP6 series actuators can be operated by the controllers indicated below. Please select the type depending on your intended use. * Please refer to P.147 for more information about the built-in controller of RCP6S series.

Name	External view	Max. number of controlled axes	Input power	Control method				Maximum number of positioning points	Reference page
				Positioner	Pulse train	Program	Network *Option		
PCON-CB/CGB		1	DC24V	● *Option	● *Option	-		512 (768 for network spec.)	Please see P.132
MCON-C/CG		4		This model is network-compatible only.				256	Please see the MCON catalog or manual.
MSEL-PC/PG		4	Single-phase 100~230VAC	-	-	●	Note: The type of compatible networks will vary depending on the controller. Please refer to reference page for more information.	30000	Please see the MSEL-PC/PG catalog or manual.

* Please select "high-output specification" as an option for the MCON. With the MCON, operation is possible only when the high-output specification is selected.

RCP6(S)-RA6R

Battery-less Absolute
Motor Unit Coupled
Side-mounted Motor
Body Width 58* mm
24v Pulse Motor

Model Specification Items	Series	Type	Encoder Type	Motor Type	Lead	Stroke	Applicable Controller/I/O Type	Cable Length	Options
	RA6R	WA	42P						
	RCP6: Separate Controller RCP6S: Built-in Controller	WA: Battery-less Absolute	42P: Pulse Motor 42□ Size	20: 20mm 12: 12mm 6: 6mm 3: 3mm	50: 50mm 300: 300mm (50mm increments)	[RCP6] P3: PCON MCON MSEL [RCP6S] SE: SIO Type	N : None P : 1m S : 3m M : 5m X□□ : Specified Length R□□ : Robot Cable	Please refer to the options table below. *Please make sure to specify ML, MR or MT when ordering the side-mounted motor type.	

* RCP6 does not include a controller. RCP6S includes a built-in controller.

* Body width does not include the width of the side-mounted motor.

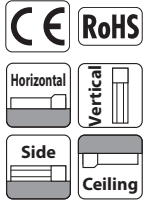

*Depending on the model, there may be some limitations to using the vertical, side, and ceiling mount positions. Please contact IAI for more information regarding mounting positions.

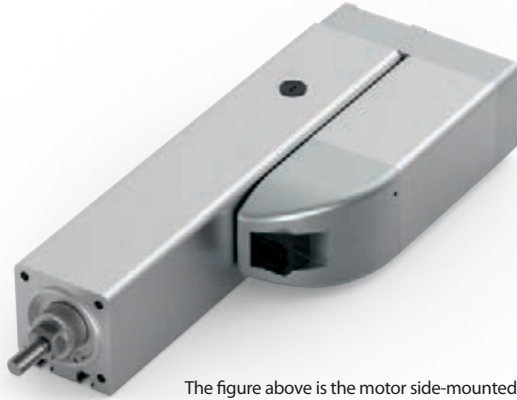

The figure above is the motor side-mounted to the left (ML).

- POINT Selection Notes**
- (1) The maximum acceleration/deceleration is 1G for horizontal, and 0.5G for vertical use.
 - (2) The actuator specification displays the payload's maximum value, but it will vary depending on the acceleration and speed. Please refer to the "Selection Guidelines" (RCP6 Tables of Payload by Speed/Acceleration) on P.115 for more details.
 - (3) The value of the horizontal payload assumes that there is an external guide. Please be aware that the anti-rotation stopper can be damaged when an external force is applied to the rod from any direction other than the moving direction.
 - (4) When performing push-motion operation, please confirm the push force of each model by checking the "Correlation diagram of push force and current limit" on P.113.
 - (5) Depending on the ambient operational temperature, duty control is necessary for the RCP6S (built-in controller type) with lead 3/6. Please refer to P.130 for more information.

Correlation Diagrams of Speed and Payload

High-output enabled (*) with PCON/MCON/MSEL connected.
RCP6(S)-RA6R Horizontal mount

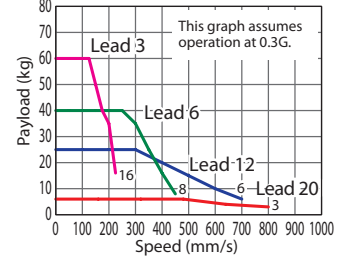

RCP6(S)-RA6R Vertical mount

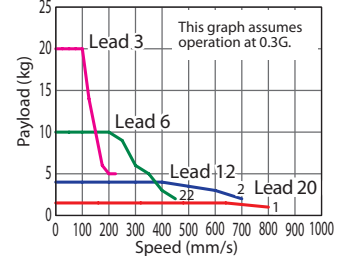

(*) For high output setting to OFF refer to the RCP6 manual.

Actuator Specifications (*)

(*) For values of disabled high output controller setting refer to the RCP6 manual.

Lead and Payload

Model Number	Lead (mm)	Connected Controller	Max. Payload		Stroke (mm)
			Horizontal (kg)	Vertical (kg)	
RCP6(S)-RA6R-WA-42P-20-①-②-③-④	20	High-output Enabled	6	1.5	50~300 (The increment of stroke is 50mm)
RCP6(S)-RA6R-WA-42P-12-①-②-③-④	12	High-output Enabled	25	4	
RCP6(S)-RA6R-WA-42P-6-①-②-③-④	6	High-output Enabled	40	10	
RCP6(S)-RA6R-WA-42P-3-①-②-③-④	3	High-output Enabled	60	20	

Stroke and Max. Speed

(Unit: mm/s)

Lead (mm)	Connected Controller	50~300 (Every 50mm)
20	High-output Enabled	800
12	High-output Enabled	700
6	High-output Enabled	450
3	High-output Enabled	225

Legend: ① Stroke ② Applicable controller/I/O type ③ Cable length ④ Options

Cable Length

Cable Type	Cable Code
Standard	P (1m)
	S (3m)
	M (5m)
Specified Length	X06 (6m) ~ X10 (10m)
	X11 (11m) ~ X15 (15m)
	X16 (16m) ~ X20 (20m)
	R01 (1m) ~ R03 (3m)
Robot Cable	R04 (4m) ~ R05 (5m)
	R06 (6m) ~ R10 (10m)
	R11 (11m) ~ R15 (15m)
	R16 (16m) ~ R20 (20m)

* Refer to P.144 for more information regarding the maintenance cables.

Options

Name	Option Code	Reference Page
Brake	B	See P.105
Cable exit direction (Outside)	CJO	See P.105
Flange	FL	See P.106
Foot bracket	FT	See P.107
Motor side-mounted to the left	ML	See P.109
Motor side-mounted to the right	MR	See P.109
Motor side-mounted to the top	MT	See P.109
Tip adapter (Internal thread)	NFA	See P.109
Non-motor end specification	NM	See P.110
T-slot nut bar	NTB	See P.110

Actuator Specifications

Item	Description
Drive system	Ball screw ø10mm, rolled C10
Positioning repeatability	±0.01mm
Lost motion	0.1mm or less
Rod	ø25mm Material: Aluminum with hard alumite treatment
Static allowable torque on rod tip	To: 1.5N·m
Max. angular displacement on rod tip (*1)	θ: ±1.0 deg.
Ambient operating temp. & humidity	0~40°C, 85% RH or less (Non-condensing)

(*1) This is the displacement angle of the rod tip (initial reference value) when the rod is fully retracted and the static allowable torque is applied at the rod tip.

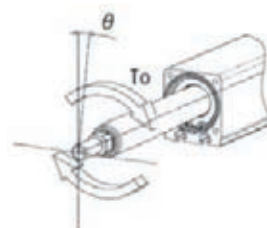

Dimensions

CAD drawings can be downloaded from our website.
www.robocylinder.de



*1 When the rod is returning to its home position, please be careful of interference from surrounding objects, as it will travel until it reaches the M.E.
M.E: Mechanical end S.E: Stroke end
*2 The direction of width across flats varies depending on the product.
Grease nipple (ø5 hole)
(Top and side)

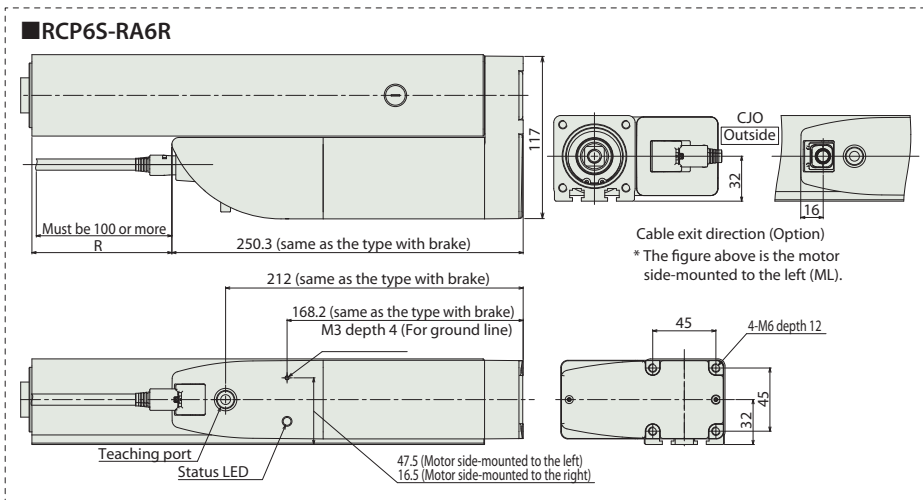
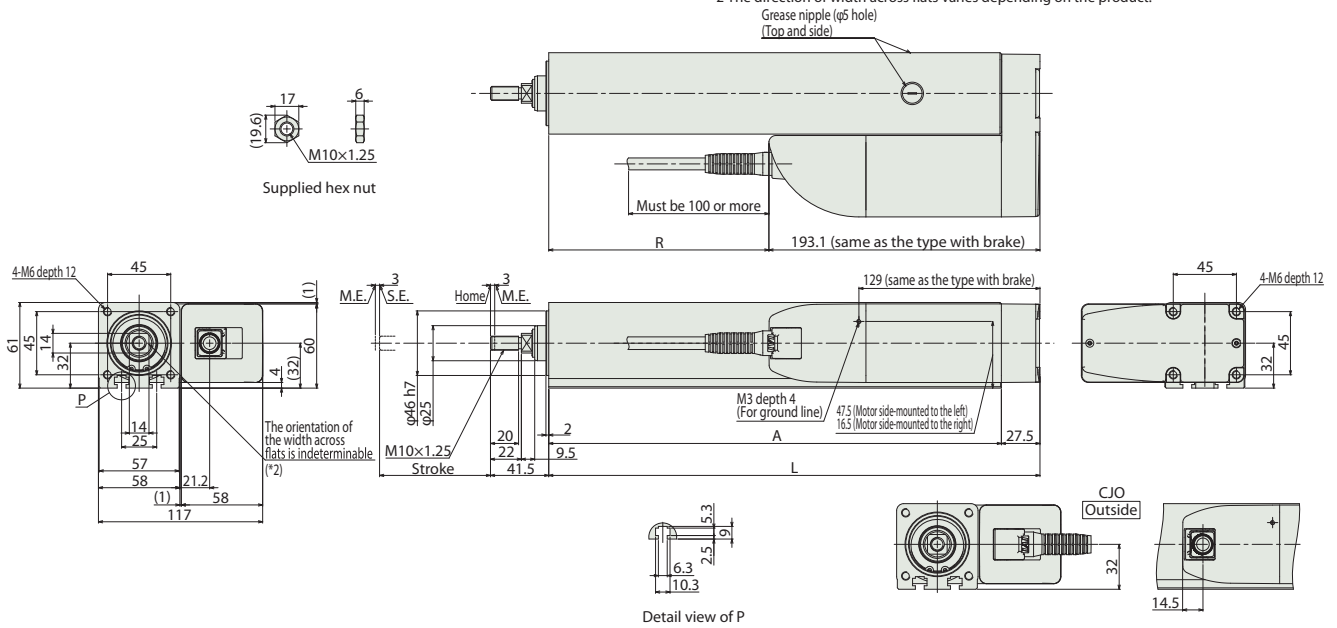

Cable exit direction (Option)
* The figure above is the motor side-mounted to the left (ML).

Cable exit direction (Option)
* The figure above is the motor side-mounted to the left (ML).

Note:
* If the length for R is negative in the table below, the length of the actuator body is shorter than the motor unit.

Dimensions and Mass by Stroke

Stroke	50	100	150	200	250	300	
L	200	250	300	350	400	450	
A	172.5	222.5	272.5	322.5	372.5	422.5	
R	RCP6	6.9	56.9	106.9	156.9	206.9	256.9
	RCP6S	-50.3	-0.3	49.7	99.7	149.7	199.7
Mass (kg)	RCP6	2.8	3.2	3.6	4.0	4.4	4.8
	w/o brake	2.9	3.3	3.7	4.1	4.5	4.9
	RCP6S	2.9	3.3	3.7	4.1	4.5	4.9
	w/o brake	3.0	3.4	3.8	4.2	4.6	5.0

Applicable Controllers

The RCP6 series actuators can be operated by the controllers indicated below. Please select the type depending on your intended use. * Please refer to P.147 for more information about the built-in controller of RCP6S series.

Name	External view	Max. number of controlled axes	Input power	Control method				Maximum number of positioning points	Reference page
				Positioner	Pulse train	Program	Network *Option		
PCON-CB/CGB		1	DC24V	● *Option	● *Option	-	DeviceNet CC-Link EtherCAT EtherNet/IP CompoNet	512 (768 for network spec.)	Please see P.132
MCON-C/CG		4		This model is network-compatible only.					
MSEL-PC/PG		4	Single-phase 100~230VAC	-	-	●	Note: The type of compatible networks will vary depending on the controller. Please refer to reference page for more information.	30000	Please see the MSEL-PC/PG catalog or manual.

* Please select "high-output specification" as an option for the MCON. With the MCON, operation is possible only when the high-output specification is selected.

RCP6(S)-RA7R

Battery-less Absolute Motor Unit Coupled Side-mounted Motor Body Width 70* mm 24v Pulse Motor

Model Specification Items	Series	Type	Encoder Type	Motor Type	Lead	Stroke	Applicable Controller/I/O Type	Cable Length	Options
	RA7R	WA	56P						
	RCP6: Separate Controller RCP6S: Built-in Controller	WA: Battery-less Absolute	56P: Pulse Motor 56□ Size	24: 24mm 16: 16mm 8: 8mm 4: 4mm	50: 50mm 300: 300mm (50mm increments)	[RCP6] P3: PCON MCON MSEL [RCP6S] SE: SIO Type	N : None P : 1m S : 3m M : 5m X□□ : Specified Length R□□ : Robot Cable	Please refer to the options table below. *Please make sure to specify ML, MR or MT when ordering the side-mounted motor type.	

* RCP6 does not include a controller. RCP6S includes a built-in controller.

* Body width does not include the width of the side-mounted motor.

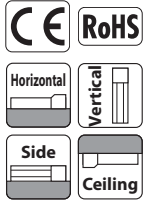

*Depending on the model, there may be some limitations to using the vertical, side, and ceiling mount positions. Please contact IAI for more information regarding mounting positions.



The figure above is the motor side-mounted to the left (ML).

- POINT Selection Notes**
- (1) The maximum acceleration/deceleration is 1G for horizontal, and 0.5G for vertical use.
 - (2) The actuator specification displays the payload's maximum value, but it will vary depending on the acceleration and speed. Please refer to the "Selection Guidelines" (RCP6 Tables of Payload by Speed/Acceleration) on P.115 for more details.
 - (3) The value of the horizontal payload assumes that there is an external guide. Please be aware that the anti-rotation stopper can be damaged when an external force is applied to the rod from any direction other than the moving direction.
 - (4) When performing push-motion operation, please confirm the push force of each model by checking the "Correlation diagram of push force and current limit" on P.113.
 - (5) Depending on the ambient operational temperature, duty control is necessary for the RCP6S (built-in controller type) with lead 4/8/16. Please refer to P.130 for more information.

Correlation Diagrams of Speed and Payload

High-output enabled (*) with PCON/MCON/MSEL connected.
RCP6(S)-RA7R Horizontal mount

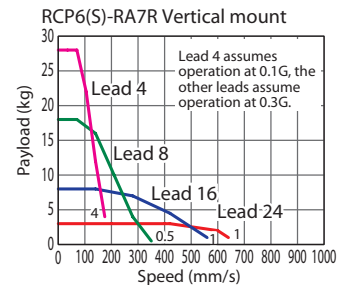
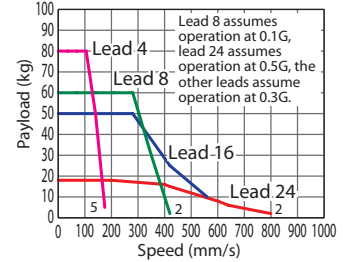

(*) For high output setting to OFF, refer to the RCP6 manual.

Actuator Specifications (*)

(*) For values of disabled high output controller setting refer to the RCP6 manual.

Lead and Payload

Model Number	Lead (mm)	Connected Controller	Max. Payload		Stroke (mm)
			Horizontal (kg)	Vertical (kg)	
RCP6(S)-RA7R-WA-56P-24-①-②-③-④	24	High-output Enabled	20	3	50~300 (The increment of stroke is 50mm)
RCP6(S)-RA7R-WA-56P-16-①-②-③-④	16	High-output Enabled	50	8	
RCP6(S)-RA7R-WA-56P-8-①-②-③-④	8	High-output Enabled	60	18	
RCP6(S)-RA7R-WA-56P-4-①-②-③-④	4	High-output Enabled	80	28	

Stroke and Max. Speed

(Unit: mm/s)

Lead (mm)	Connected Controller	50~300 (Every 50mm)
24	High-output Enabled	800 <640>
16	High-output Enabled	560
8	High-output Enabled	420 <350>
4	High-output Enabled	175

Legend: ① Stroke ② Applicable controller/I/O type ③ Cable length ④ Options

Values in brackets < > are for vertical use.

Cable Length

Cable Type	Cable Code
Standard	P (1m)
	S (3m)
	M (5m)
Specified Length	X06 (6m) ~ X10 (10m)
	X11 (11m) ~ X15 (15m)
	X16 (16m) ~ X20 (20m)
Robot Cable	R01 (1m) ~ R03 (3m)
	R04 (4m) ~ R05 (5m)
	R06 (6m) ~ R10 (10m)
	R11 (11m) ~ R15 (15m)
	R16 (16m) ~ R20 (20m)
	R20 (20m)

* Refer to P.144 for more information regarding the maintenance cables.

Options

Name	Option Code	Reference Page
Brake	B	See P.105
Cable exit direction (Outside)	CJO	See P.105
Flange	FL	See P.106
Foot bracket	FT	See P.107
Motor side-mounted to the left	ML	See P.109
Motor side-mounted to the right	MR	See P.109
Motor side-mounted to the top	MT	See P.109
Tip adapter (Internal thread)	NFA	See P.109
Non-motor end specification	NM	See P.110
T-slot nut bar	NTB	See P.110

Actuator Specifications

Item	Description
Drive system	Ball screw ø12mm, rolled C10
Positioning repeatability	±0.01mm
Lost motion	0.1mm or less
Rod	ø30mm Material: Aluminum with hard alumite treatment
Static allowable torque on rod tip	To: 2.5N·m
Max. angular displacement on rod tip (*1)	θ: ±0.8 deg.
Ambient operating temp. & humidity	0~40°C, 85% RH or less (Non-condensing)

(*1) This is the displacement angle of the rod tip (initial reference value) when the rod is fully retracted and the static allowable torque is applied at the rod tip.

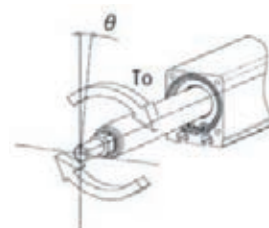

Dimensions

CAD drawings can be downloaded from our website.
www.robocylinder.de



*1 When the rod is returning to its home position, please be careful of interference from surrounding objects, as it will travel until it reaches the M.E.

M.E: Mechanical end S.E: Stroke end

*2 The direction of width across flats varies depending on the product.
 Grease nipple (ø5 hole)
 (Top and side)

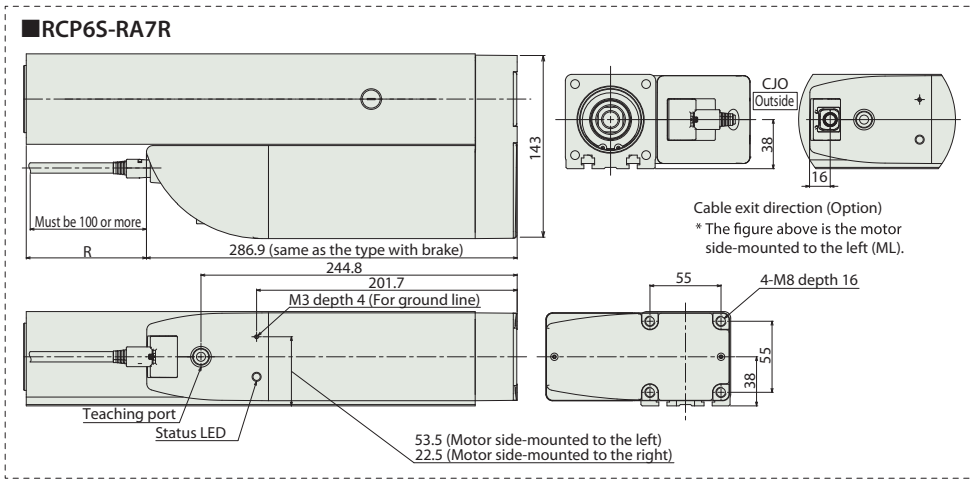
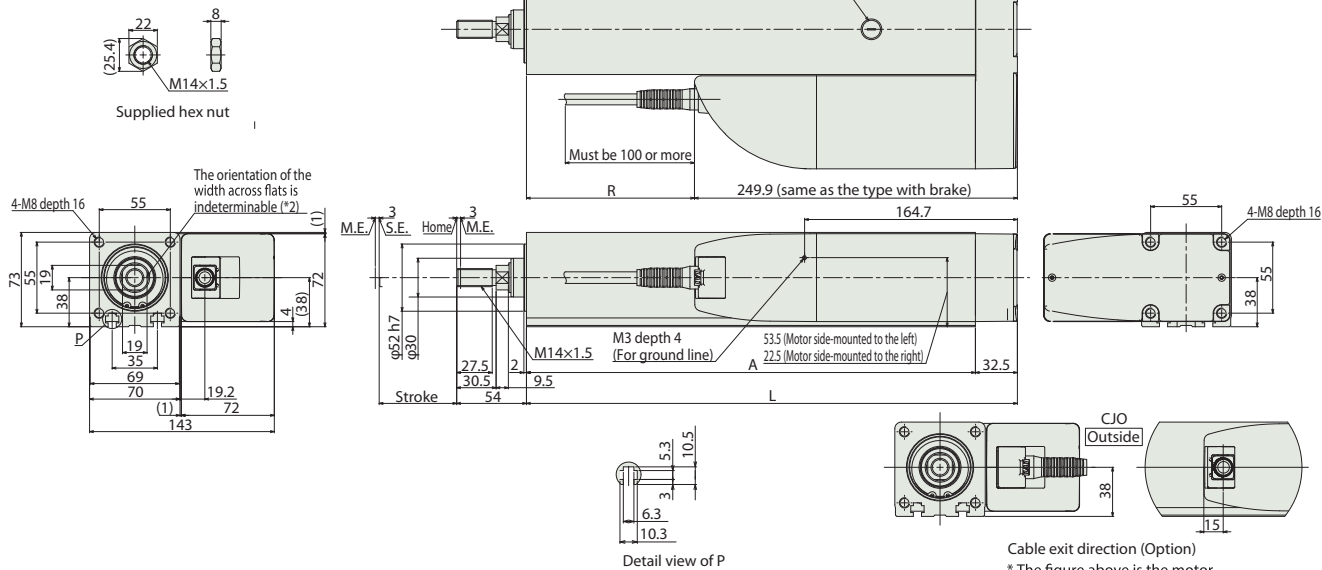

Note:
 * If the length for R is negative in the table below, the length of the actuator body is shorter than the motor unit.

Dimensions and Mass by Stroke

Stroke	50	100	150	200	250	300		
L	230	280	330	380	430	480		
A	197.5	247.5	297.5	347.5	397.5	447.5		
R	RCP6	-19.9	30.1	80.1	130.1	180.1	230.1	
	RCP6S	-56.9	-6.9	43.1	93.1	143.1	193.1	
Mass (kg)	RCP6	w/o brake	5.1	5.7	6.3	6.9	7.5	8.1
		w/ brake	5.2	5.8	6.4	7.0	7.6	8.2
	RCP6S	w/o brake	5.2	5.8	6.4	7.0	7.6	8.1
		w/ brake	5.3	5.9	6.5	7.1	7.7	8.2

Applicable Controllers

The RCP6 series actuators can be operated by the controllers indicated below. Please select the type depending on your intended use. * Please refer to P.147 for more information about the built-in controller of RCP6S series.

Name	External view	Max. number of controlled axes	Input power	Control method				Maximum number of positioning points	Reference page
				Positioner	Pulse train	Program	Network *Option		
PCON-CB/CGB		1	DC24V	● *Option	● *Option	-		512 (768 for network spec.)	Please see P.132
MCON-C/CG		4		This model is network-compatible only.				256	Please see the MCON catalog or manual.
MSEL-PC/PG		4	Single-phase 100~230VAC	-	-	●	Note: The type of compatible networks will vary depending on the controller. Please refer to reference page for more information.	30000	Please see the MSEL-PC/PG catalog or manual.

* Please select "high-output specification" as an option for the MCON. With the MCON, operation is possible only when the high-output specification is selected.

RCP6(S)-RA8R

Battery-less Absolute
Motor Unit Coupled
Side-mounted Motor
Body Width 85* mm
24v Pulse Motor

Model Specification Items	Series	Type	Encoder Type	Motor Type	Lead	Stroke	Applicable Controller/I/O Type	Cable Length	Options
	RA8R	WA	60P						
	RCP6: Separate Controller RCP6S: Built-in Controller	WA: Battery-less Absolute	60P: Pulse Motor 60□ Size	20: 20mm 10: 10mm 5: 5mm	50: 50mm 300: 300mm (50mm increments)	[RCP6] P4: PCON- CFB/CGFB [RCP6S] SE: SIO Type	N : None P : 1m S : 3m M : 5m X□ : Specified Length R□ : Robot Cable	Please refer to the options table below. *Please make sure to specify ML, MR or MT when ordering the side-mounted motor type.	

* RCP6 does not include a controller. RCP6S includes a built-in controller.

* Body width does not include the width of the side-mounted motor.

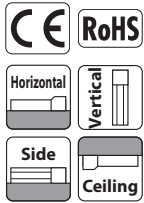

*Depending on the model, there may be some limitations to using the vertical, side, and ceiling mount positions. Please contact IAI for more information regarding mounting positions.



The figure above is the motor side-mounted to the left (ML).

- POINT Selection Notes**
- (1) The maximum acceleration/deceleration is 0.1G for lead 5 and 0.2G for lead 10/20.
 - (2) The actuator specification displays the payload's maximum value, but it will vary depending on the acceleration and speed. Please refer to the "Selection Guidelines" (RCP6 Tables of Payload by Speed/Acceleration) on P.115 for more details.
 - (3) The value of the horizontal payload assumes that there is an external guide. Please be aware that the anti-rotation stopper can be damaged when an external force is applied to the rod from any direction other than the moving direction.
 - (4) When performing push-motion operation, please confirm the push force of each model by checking the "Correlation diagram of push force and current limit" on P.113.
 - (5) For RCP6S (built-in controller type), please limit the duty cycle to 70% or less.
 - (6) The service life of an actuator varies depending on the payload when using vertically. Please refer to P. 114 for more information.

Correlation Diagrams of Speed and Payload

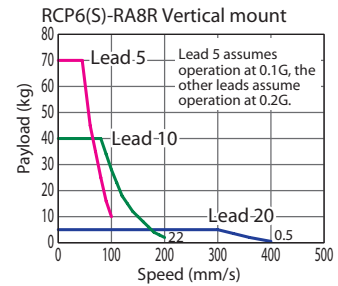
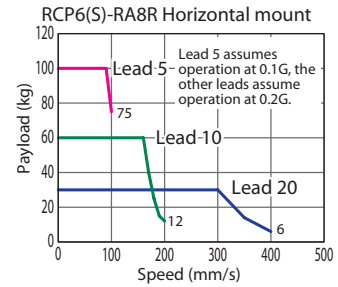

Actuator Specifications

Lead and Payload

Model Number	Lead (mm)	Max. Payload (kg)		Stroke (mm)
		Horizontal (kg)	Vertical (kg)	
RCP6(S)-RA8R-WA-60P-20-①-②-③-④	20	30	5	50~300 (The increment of stroke is 50mm)
RCP6(S)-RA8R-WA-60P-10-①-②-③-④	10	60	40	
RCP6(S)-RA8R-WA-60P-5-①-②-③-④	5	100	70	

Legend: ① Stroke ② Applicable controller/I/O type ③ Cable length ④ Options

Stroke and Max. Speed

(Unit: mm/s)

Lead (mm)	50~300 (Every 50mm)
20	400
10	200
5	100

Cable Length

Cable Type	Cable Code
Standard	P (1m)
	S (3m)
	M (5m)
Specified Length	X06 (6m) ~ X10 (10m)
	X11 (11m) ~ X15 (15m)
	X16 (16m) ~ X20 (20m)
	R01 (1m) ~ R03 (3m)
Robot Cable	R04 (4m) ~ R05 (5m)
	R06 (6m) ~ R10 (10m)
	R11 (11m) ~ R15 (15m)
	R16 (16m) ~ R20 (20m)

* Refer to P.144 for more information regarding the maintenance cables.

Options

Name	Option Code	Reference Page
Brake	B	See P.105
Cable exit direction (Outside)	CJO	See P.105
Flange	FL	See P.106
Foot bracket	FT	See P.107
Motor side-mounted to the left	ML	See P.109
Motor side-mounted to the right	MR	See P.109
Motor side-mounted to the top	MT	See P.109
Tip adapter (Internal thread)	NFA	See P.109
Non-motor end specification	NM	See P.110
T-slot nut bar	NTB	See P.110

Actuator Specifications

Item	Description
Drive system	Ball screw ø16mm, rolled C10
Positioning repeatability	±0.01mm
Lost motion	0.1mm or less
Rod	ø40mm Material: Aluminum with hard alumite treatment
Static allowable torque on rod tip	To: 5.0N·m
Max. angular displacement on rod tip (*1)	θ: ±0.8 deg.
Ambient operating temp. & humidity	0~40°C, 85% RH or less (Non-condensing)

(*1) This is the displacement angle of the rod tip (initial reference value) when the rod is fully retracted and the static allowable torque is applied at the rod tip.

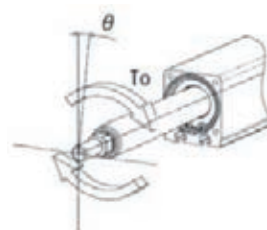

Dimensions

CAD drawings can be downloaded from our website.
www.robocylinder.de



*1 When the rod is returning to its home position, please be careful of interference from surrounding objects, as it will travel until it reaches the M.E.

M.E: Mechanical end S.E: Stroke end

*2 The direction of width across flats varies depending on the product.

Grease nipple (φ5 hole)
(Top and side)

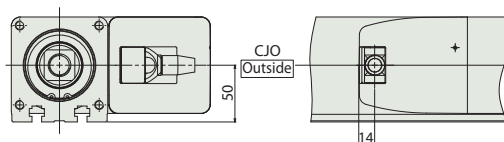
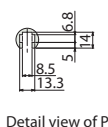
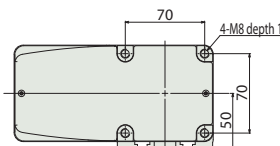
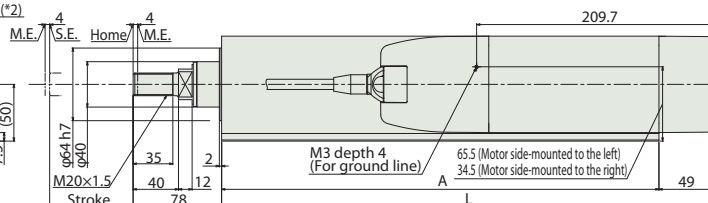
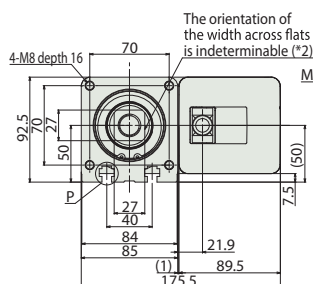
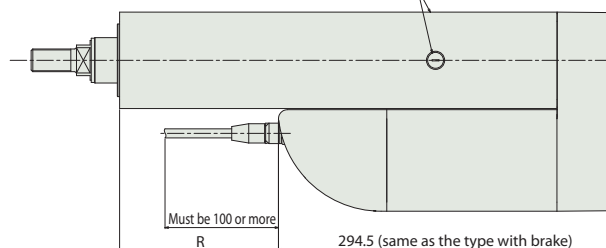
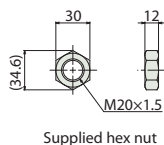

Cable exit direction (Option)

* The figure above is the motor side-mounted to the left (ML).

RCP6S-RA8R

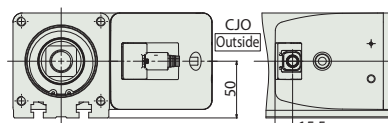
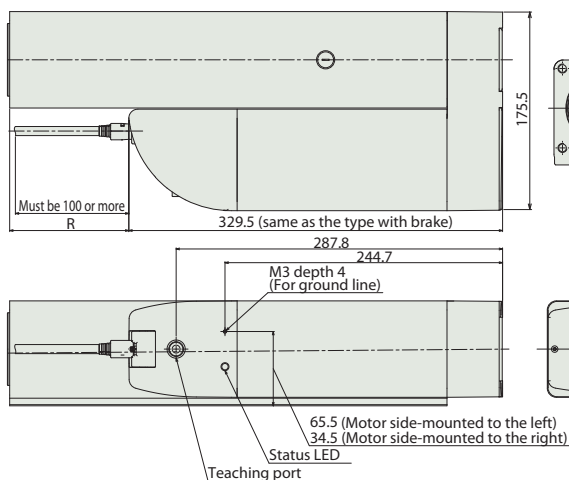

Cable exit direction (Option)

* The figure above is the motor side-mounted to the left (ML).

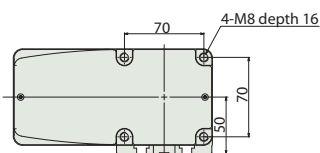

Note:

* If the length for R is negative in the table below, the length of the actuator body is shorter than the motor unit.

Dimensions and Mass by Stroke

		Stroke	50	100	150	200	250	300
	L	284.5	334.5	384.5	434.5	484.5	534.5	
	A	235.5	285.5	335.5	385.5	435.5	485.5	
R	RCP6	-10	40	90	140	190	240	
	RCP6S	-45	5	55	105	155	205	
Mass (kg)	RCP6	w/o brake	9.0	9.9	10.8	11.7	12.6	13.5
		w/brake	9.2	10.1	11.0	11.9	12.8	13.7
	RCP6S	w/o brake	9.2	10.1	11.0	11.9	12.8	13.7
		w/brake	9.4	10.3	11.2	12.1	13.0	13.9

Applicable Controllers

The RCP6 series actuators can be operated by the controllers indicated below. Please select the type depending on your intended use. * Please refer to P.147 for more information about the built-in controller of RCP6S series.

Name	External view	Max. number of controlled axes	Input power	Control method			Maximum number of positioning points	Reference page
				Positioner	Pulse train	Program		
PCON-CFB/CGFB		1	DC24V	●	●	-	512 (768 for network spec.)	Please see P.132
				*Option	*Option			
							DeviceNet CompoNet EtherNet/IP 	

RCP6(S)-RRA4C

Battery-less Absolute
Motor Unit Coupled
Straight Motor
Body Width 40mm
24v Pulse Motor

Model Specification Items	Series	Type	Encoder Type	Motor Type	Lead	Stroke	Applicable Controller/I/O Type	Cable Length	Options
	RRA4C	WA	35P						
	RCP6: Separate Controller RCP6S: Built-in Controller	WA: Battery-less Absolute	35P: Pulse Motor 35□ Size	16: 16mm 10: 10mm 5: 5mm 2.5: 2.5mm	60: 60mm 410: 410mm (50mm increments)	[RCP6] P3: PCON MCON MSEL [RCP6S] SE: SIO Type	N : None P : 1m S : 3m M : 5m X□ : Specified Length R□ : Robot Cable	Please refer to the options table below.	

* RCP6 does not include a controller. RCP6S includes a built-in controller.

Radial Load OK

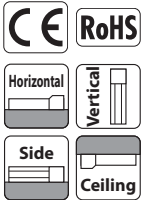

*Depending on the model, there may be some limitations to using the vertical, side, and ceiling mount positions. Please contact IAI for more information regarding mounting positions.

- POINT Selection Notes**
- (1) The maximum acceleration/deceleration is 1G for horizontal, and 0.5G for vertical use.
 - (2) The actuator specification displays the payload's maximum value, but it will vary depending on the acceleration and speed. Please refer to the "Selection Guidelines" (RCP6 Tables of Payload by Speed/Acceleration) on P.115 for more details.
 - (3) The radial cylinder is equipped with a built-in guide. Please refer to the graphs shown in P.127 and after for the allowable load mass.
 - (4) When performing push-motion operation, please confirm the push force of each model by checking the "Correlation diagram of push force and current limit" on P.113.

Correlation Diagrams of Speed and Payload

High-output enabled (*) with PCON/MCON/MSEL connected.
RCP6(S)-RRA4C Horizontal mount

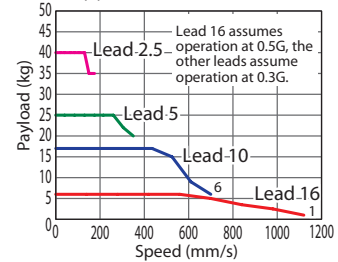

RCP6(S)-RRA4C Vertical mount

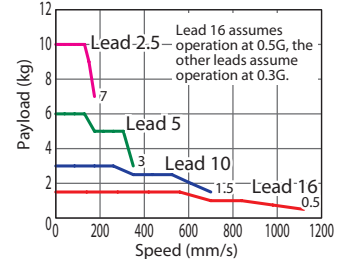

(*) For high output setting to OFF refer to the RCP6 manual.

Actuator Specifications (*)

(*) For values of disabled high output controller setting refer to the RCP6 manual.

Lead and Payload

(**) The payload assumes that there is an external guide.

Model Number	Lead (mm)	Connected Controller	Max. Payload		Stroke (mm)
			Horizontal (kg) (**)	Vertical (kg)	
RCP6(S)-RRA4C-WA-35P-16-①-②-③-④	16	High-output Enabled	7	1.5	60~410 (The increment of stroke is 50mm)
RCP6(S)-RRA4C-WA-35P-10-①-②-③-④	10	High-output Enabled	18	3	
RCP6(S)-RRA4C-WA-35P-5-①-②-③-④	5	High-output Enabled	28	6	
RCP6(S)-RRA4C-WA-35P-2.5-①-②-③-④	2.5	High-output Enabled	40	10	

Stroke and Max. Speed

(Unit: mm/s)

Lead (mm)	Connected Controller	60~360 (Every 50mm)	410 (mm)
16	High-output Enabled	1120	1080
10	High-output Enabled	700	685
5	High-output Enabled	350	340
2.5	High-output Enabled	175	170

Legend: ① Stroke ② Applicable controller/I/O type ③ Cable length ④ Options

Cable Length

Cable Type	Cable Code
Standard	P (1m)
	S (3m)
	M (5m)
Specified Length	X06 (6m) ~ X10 (10m)
	X11 (11m) ~ X15 (15m)
	X16 (16m) ~ X20 (20m)
	R01 (1m) ~ R03 (3m)
Robot Cable	R04 (4m) ~ R05 (5m)
	R06 (6m) ~ R10 (10m)
	R11 (11m) ~ R15 (15m)
	R16 (16m) ~ R20 (20m)

* Refer to P.144 for more information regarding the maintenance cables.

Options

Name	Option Code	Reference Page
Brake	B	See P.105
Cable exit direction (Top)	CJT	See P.105
Cable exit direction (Right)	CJR	See P.105
Cable exit direction (Left)	CJL	See P.105
Cable exit direction (Bottom)	CJB	See P.105
Flange	FL	See P.106
Tip adapter (Flange)	FFA	See P.105
Tip adapter (Internal thread)	NFA	See P.109
Tip adapter (Keyway)	KFA	See P.108
Non-motor end specification	NM	See P.110

Actuator Specifications

Item	Description
Drive system	Ball screw ø8mm, rolled C10
Positioning repeatability	±0.01mm
Lost motion	0.1mm or less
Rod	ø20mm Aluminum
Rod non-rotation precision (*)	0 deg.
Allowable load and torque on rod tip	See P. 127
Rod tip offset/overhang distance	dx/dz: 100mm or less
Ambient operating temp. & humidity	0~40°C, 85% RH or less (Non-condensing)

(*) Rod's angular displacement in rotational direction with no load applied to the rod.

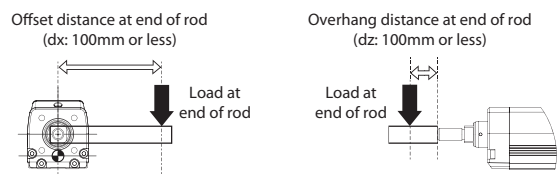

Dimensions

CAD drawings can be downloaded from our website.
www.robocylinder.de



- *1 When the rod is returning to its home position, please be careful of interference from surrounding objects, as it will travel until it reaches the M.E. M.E: Mechanical end S.E: Stroke end
- *2 The direction of width across flats varies depending on the product.
- *3 When fixing the actuator using a front bracket or flange, please make sure that there is no external force applied to the main body.

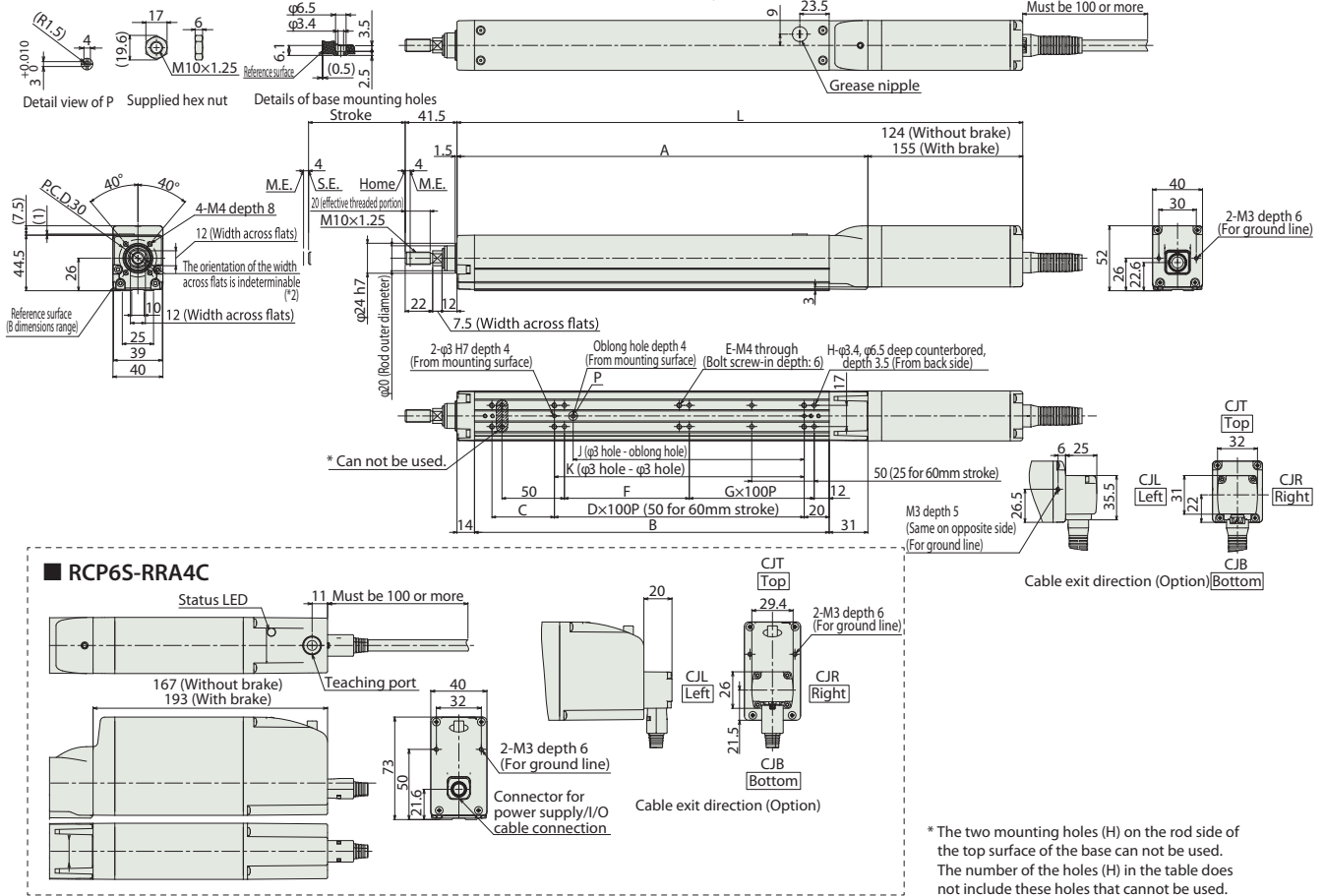

* The two mounting holes (H) on the rod side of the top surface of the base can not be used. The number of the holes (H) in the table does not include these holes that cannot be used.

■ Dimensions and Mass by Stroke

L	Stroke	Stroke									
		60	110	160	210	260	310	360	410		
RCP6	w/o brake	303	353	403	453	503	553	603	653		
	w/ brake	334	384	434	484	534	584	634	684		
RCP6S	w/o brake	346	396	446	496	546	596	646	696		
	w/ brake	372	422	472	522	572	622	672	722		
A		179	229	279	329	379	429	479	529		
B		134	184	234	284	334	384	434	484		
C		50	50	100	50	100	50	100	50		
D		0	1	1	2	2	3	3	4		
E		6	6	6	8	8	10	10	12		
F		50	100	50	100	50	100	50	100		
G		0	0	1	1	2	2	3	3		
H		6	6	8	8	10	10	12	12		
J		35	85	85	185	185	285	285	385		
K		50	100	100	200	200	300	300	400		
Allowable static load on rod tip (N)		63.4	50.7	42.1	36	31.3	27.6	24.6	22.2		
Allowable dynamic Load offset 0mm		2.9	2.3	1.8	1.5	1.3	1.1	1.0	0.8		
load on rod tip (kg) Load offset 100mm		1.8	1.6	1.4	1.2	1.0	0.9	0.8	0.7		
Allowable static torque on rod tip (N·m)		6.4	5.1	4.3	3.7	3.2	2.9	2.6	2.3		
Allowable dynamic torque on rod tip (N·m)		1.7	1.5	1.3	1.1	1.0	0.9	0.7	0.7		
Mass (kg)	RCP6	w/o brake	1.2	1.4	1.5	1.6	1.7	1.9	2.0	2.1	
		w/ brake	1.4	1.5	1.7	1.8	1.9	2.0	2.2	2.3	
	RCP6S	w/o brake	1.4	1.6	1.7	1.8	1.9	2.1	2.2	2.3	
		w/ brake	1.6	1.7	1.8	2.0	2.1	2.2	2.3	2.5	

■ Rod Deflection of RCP6(S)-RAA4C (Reference Values)

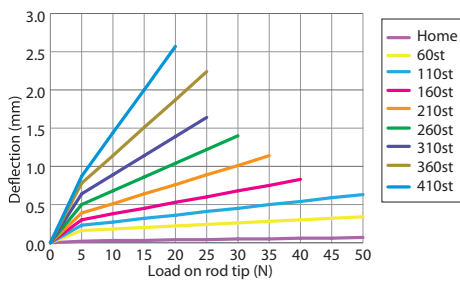

Applicable Controllers

The RCP6 series actuators can be operated by the controllers indicated below. Please select the type depending on your intended use. * Please refer to P.147 for more information about the built-in controller of RCP6S series.

Name	External view	Max. number of controlled axes	Input power	Control method				Maximum number of positioning points	Reference page
				Positioner	Pulse train	Program	Network *Option		
PCON-CB/CGB		1	DC24V	*Option	*Option	-	DeviceNet CC-Link EtherCAT EtherNet/IP CompoNet	512 (768 for network spec.)	Please see P.132
MCON-C/CG		4		This model is network-compatible only.				256	Please see the MCON catalog or manual.
MSEL-PC/PG		4	Single-phase 100~230VAC	-	-	●	Note: The type of compatible networks will vary depending on the controller. Please refer to reference page for more information.	30000	Please see the MSEL-PC/PG catalog or manual.

* Please select "high-output specification" as an option for the MCON. With the MCON, operation is possible only when the high-output specification is selected.

RCP6(S)-RRA6C

Battery-less Absolute
Motor Unit Coupled
Straight Motor
Body Width 58 mm
24v Pulse Motor

Model Specification Items	Series	Type	Encoder Type	Motor Type	Lead	Stroke	Applicable Controller/I/O Type	Cable Length	Options
	RCP6	RRA6C	WA	42P					
	RCP6: Separate Controller RCP6S: Built-in Controller		WA: Battery-less Absolute	42P: Pulse Motor 42□ Size	20: 20mm 12: 12mm 6: 6mm 3: 3mm	65: 65mm 415: 415mm (50mm increments)	[RCP6] P3: PCON MCON MSEL [RCP6S] SE: SIO Type	N : None P : 1m S : 3m M : 5m X□ : Specified Length R□ : Robot Cable	Please refer to the options table below.

* RCP6 does not include a controller. RCP6S includes a built-in controller.

Radial Load OK

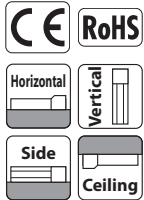

*Depending on the model, there may be some limitations to using the vertical, side, and ceiling mount positions. Please contact IAI for more information regarding mounting positions.



- (1) The maximum acceleration/deceleration is 1G for horizontal, and 0.5G for vertical use.
- (2) The actuator specification displays the payload's maximum value, but it will vary depending on the acceleration and speed. Please refer to the "Selection Guidelines" (RCP6 Tables of Payload by Speed/Acceleration) on P.115 for more details.
- (3) The radial cylinder is equipped with a built-in guide. Please refer to the graphs shown in P.127 and after for the allowable load mass.
- (4) When performing push-motion operation, please confirm the push force of each model by checking the "Correlation diagram of push force and current limit" on P.113.
- (5) Depending on the ambient operational temperature, duty control is necessary for the RCP6S (built-in controller type) with lead 3/6. Please refer to P.130 for more information.

Correlation Diagrams of Speed and Payload

High-output enabled (*) with PCON/MCON/MSEL connected.
RCP6(S)-RRA6C Horizontal mount

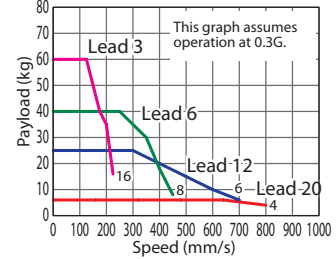

RCP6(S)-RRA6C Vertical mount

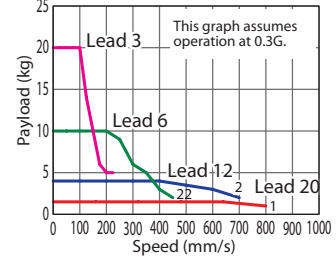

(*) For high output setting to OFF, refer to the RCP6 manual.

Actuator Specifications (*)

(*) For values of disabled high output controller setting refer to the RCP6 manual.

Lead and Payload

(**) The payload assumes that there is an external guide.

Model Number	Lead (mm)	Connected Controller	Max. Payload		Stroke (mm)
			Horizontal (kg) (**)	Vertical (kg)	
RCP6(S)-RRA6C-WA-42P-20-①-②-③-④	20	High-output Enabled	6	1.5	65~415 (The increment of stroke is 50mm)
RCP6(S)-RRA6C-WA-42P-12-①-②-③-④	12	High-output Enabled	25	4	
RCP6(S)-RRA6C-WA-42P-6-①-②-③-④	6	High-output Enabled	40	10	
RCP6(S)-RRA6C-WA-42P-3-①-②-③-④	3	High-output Enabled	60	20	

Stroke and Max. Speed

(Unit: mm/s)

Lead (mm)	Connected Controller	65~365 (Every 50mm)	415 (mm)
20	High-output Enabled	800	
12	High-output Enabled	700	
6	High-output Enabled	450	
3	High-output Enabled	225	220

Legend: ① Stroke ② Applicable controller/I/O type ③ Cable length ④ Options

Cable Length

Cable Type	Cable Code
Standard	P (1m)
	S (3m)
	M (5m)
Specified Length	X06 (6m) ~ X10 (10m)
	X11 (11m) ~ X15 (15m)
	X16 (16m) ~ X20 (20m)
Robot Cable	R01 (1m) ~ R03 (3m)
	R04 (4m) ~ R05 (5m)
	R06 (6m) ~ R10 (10m)
	R11 (11m) ~ R15 (15m)
	R16 (16m) ~ R20 (20m)
	R20 (20m)

* Refer to P.144 for more information regarding the maintenance cables.

Options

Name	Option Code	Reference Page
Brake	B	See P.105
Cable exit direction (Top)	CJT	See P.105
Cable exit direction (Right)	CJR	See P.105
Cable exit direction (Left)	CJL	See P.105
Cable exit direction (Bottom)	CJB	See P.105
Flange	FL	See P.106
Tip adapter (Flange)	FFA	See P.105
Tip adapter (Internal thread)	NFA	See P.109
Tip adapter (Keyway)	KFA	See P.108
Non-motor end specification	NM	See P.110

Actuator Specifications

Item	Description
Drive system	Ball screw ø10mm, rolled C10
Positioning repeatability	±0.01mm
Lost motion	0.1mm or less
Rod	ø25mm Aluminum
Rod non-rotation precision (*)	0 deg.
Allowable load and torque on rod tip	See P. 127
Rod tip offset/overhang distance	dx/dz: 100mm or less
Ambient operating temp. & humidity	0~40°C, 85% RH or less (Non-condensing)

(*) Rod's angular displacement in rotational direction with no load applied to the rod.

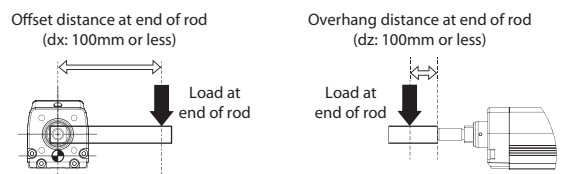

Dimensions

CAD drawings can be downloaded from our website.
www.robocylinder.de



- *1 When the rod is returning to its home position, please be careful of interference from surrounding objects, as it will travel until it reaches the M.E. M.E: Mechanical end S.E: Stroke end
- *2 The direction of width across flats varies depending on the product.
- *3 When fixing the actuator using a front bracket or flange, please make sure that there is no external force applied to the main body.

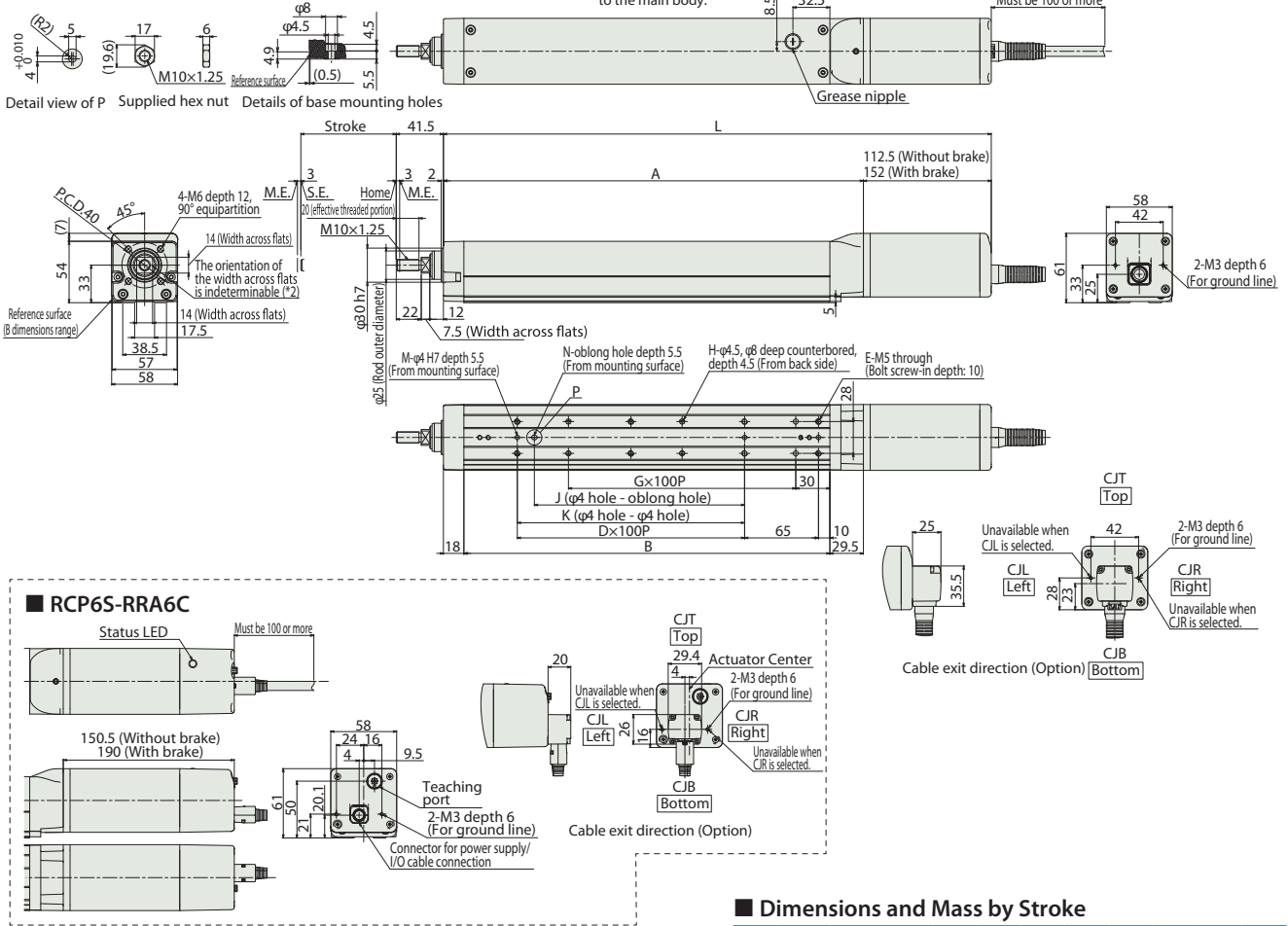

■ Dimensions and Mass by Stroke

		Stroke	65	115	165	215	265	315	365	415
L	RCP6	w/o brake	332	382	432	482	532	582	632	682
		w/ brake	371.5	421.5	471.5	521.5	571.5	621.5	671.5	721.5
	RCP6S	w/o brake	370	420	470	520	570	620	670	720
		w/ brake	409.5	459.5	509.5	559.5	609.5	659.5	709.5	759.5
A			219.5	269.5	319.5	369.5	419.5	469.5	519.5	569.5
B			172	222	272	322	372	422	472	522
D			0	1	1	2	2	3	3	4
E			4	6	6	8	8	10	10	12
G			1	1	2	2	3	3	4	4
H			4	4	6	6	8	8	10	10
J			0	85	85	185	185	285	285	385
K			0	100	100	200	200	300	300	400
M			2	3	3	3	3	3	3	3
N			0	1	1	1	1	1	1	1
Allowable static load on rod tip (N)			144	117	99	85.4	75	66.7	59.9	54.3
Allowable dynamic Load offset 0mm			5.9	4.7	3.9	3.3	2.8	2.5	2.2	2.0
load on rod tip (kg) Load offset 100mm			4.0	3.5	3.0	2.7	2.4	2.1	1.9	1.7
Allowable static torque on rod tip (N·m)			14.5	11.8	10.0	8.7	7.6	6.8	6.2	5.6
Allowable dynamic torque on rod tip (N·m)			3.8	3.3	2.9	2.6	2.3	2.0	1.8	1.6
Mass (kg)	RCP6	w/o brake	2.1	2.3	2.6	2.8	3.0	3.2	3.5	3.7
		w/ brake	2.4	2.6	2.8	3.0	3.3	3.5	3.7	3.9
	RCP6S	w/o brake	2.3	2.5	2.7	2.9	3.2	3.4	3.6	3.8
		w/ brake	2.5	2.7	3.0	3.2	3.4	3.6	3.8	4.1

■ Rod Deflection of RCP6(S)-RRA6C (Reference Values)

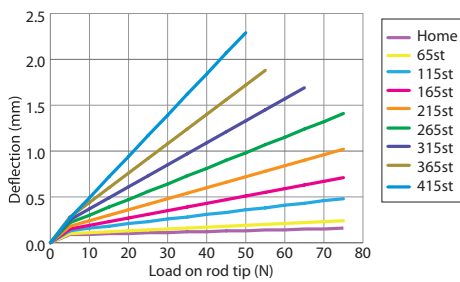

Applicable Controllers

The RCP6 series actuators can be operated by the controllers indicated below. Please select the type depending on your intended use. * Please refer to P.147 for more information about the built-in controller of RCP6S series.

Name	External view	Max. number of controlled axes	Input power	Control method				Maximum number of positioning points	Reference page
				Positioner	Pulse train	Program	Network *Option		
PCON-CB/CGB		1	DC24V	● *Option	● *Option	-	 	512 (768 for network spec.)	Please see P.132
MCON-C/CG		4		This model is network-compatible only.					
MSEL-PC/PG		4	Single-phase 100~230VAC	-	-	●	Note: The type of compatible networks will vary depending on the controller. Please refer to reference page for more information.	30000	Please see the MSEL-PC/PG catalog or manual.

* Please select "high-output specification" as an option for the MCON. With the MCON, operation is possible only when the high-output specification is selected.

RCP6(S)-RRA7C

Battery-less Absolute
Motor Unit Coupled
Straight Motor
Body Width 70mm
24v Pulse Motor

Model Specification Items	Series	RRA7C	Type	WA	Encoder Type	56P	Motor Type	Lead	Stroke	Applicable Controller/I/O Type	Cable Length	Options
	RCP6: Separate Controller RCP6S: Built-in Controller	WA: Battery-less Absolute	56P: Pulse Motor 56□ Size	24: 24mm 16: 16mm 8: 8mm 4: 4mm	70: 70mm 520: 520mm (50mm increments)	[RCP6] P3: PCON MCON MSEL [RCP6S] SE: SIO Type	N : None P : 1m S : 3m M : 5m X□ : Specified Length R□ : Robot Cable	Please refer to the options table below.				

* RCP6 does not include a controller. RCP6S includes a built-in controller.

Radial Load OK

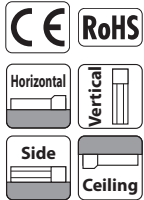

*Depending on the model, there may be some limitations to using the vertical, side, and ceiling mount positions. Please contact IAI for more information regarding mounting positions.



- (1) The maximum acceleration/deceleration is 1G for horizontal, and 0.5G for vertical use.
- (2) The actuator specification displays the payload's maximum value, but it will vary depending on the acceleration and speed. Please refer to the "Selection Guidelines" (RCP6 Tables of Payload by Speed/Acceleration) on P.115 for more details.
- (3) The radial cylinder is equipped with a built-in guide. Please refer to the graphs shown in P.127 and after for the allowable load mass.
- (4) When performing push-motion operation, please confirm the push force of each model by checking the "Correlation diagram of push force and current limit" on P.113.
- (5) Depending on the ambient operational temperature, duty control is necessary for the RCP6S (built-in controller type) with lead 4/8/16. Please refer to P.130 for more information.

Correlation Diagrams of Speed and Payload

High-output enabled (*) with PCON/MCON/MSEL connected.

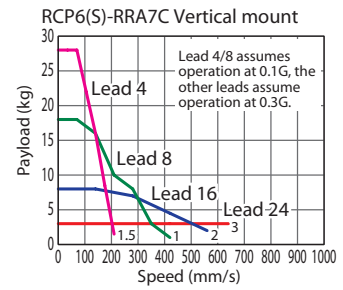
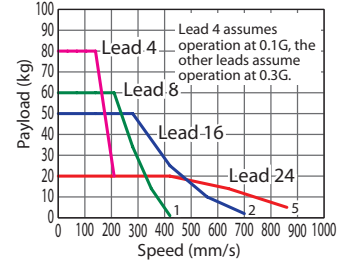

(*) For high output setting to OFF refer to the RCP6 manual.

Actuator Specifications (*)

(*) For values of disabled high output controller setting refer to the RCP6 manual.

Lead and Payload

(**) The payload assumes that there is an external guide.

Model Number	Lead (mm)	Connected Controller	Max. Payload		Stroke (mm)
			Horizontal (kg) (**)	Vertical (kg)	
RCP6(S)-RRA7C-WA-56P-24-①-②-③-④	24	High-output Enabled	20	3	70~520 (The increment of stroke is 50mm)
RCP6(S)-RRA7C-WA-56P-16-①-②-③-④	16	High-output Enabled	50	8	
RCP6(S)-RRA7C-WA-56P-8-①-②-③-④	8	High-output Enabled	60	18	
RCP6(S)-RRA7C-WA-56P-4-①-②-③-④	4	High-output Enabled	80	28	

Stroke and Max. Speed

(Unit: mm/s)

Lead (mm)	Connected Controller	70~520 (Every 50mm)
24	High-output Enabled	860 <640>
16	High-output Enabled	700 <560>
8	High-output Enabled	420
4	High-output Enabled	210

Legend: ① Stroke ② Applicable controller/I/O type ③ Cable length ④ Options

Values in brackets < > are for vertical use.

Cable Length

Cable Type	Cable Code
Standard	P (1m)
	S (3m)
	M (5m)
Specified Length	X06 (6m) ~ X10 (10m)
	X11 (11m) ~ X15 (15m)
	X16 (16m) ~ X20 (20m)
	R01 (1m) ~ R03 (3m)
Robot Cable	R04 (4m) ~ R05 (5m)
	R06 (6m) ~ R10 (10m)
	R11 (11m) ~ R15 (15m)
	R16 (16m) ~ R20 (20m)

* Refer to P.144 for more information regarding the maintenance cables.

Options

Name	Option Code	Reference Page
Brake	B	See P.105
Cable exit direction (Top)	CJT	See P.105
Cable exit direction (Right)	CJR	See P.105
Cable exit direction (Left)	CJL	See P.105
Cable exit direction (Bottom)	CJB	See P.105
Flange	FL	See P.106
Tip adapter (Flange)	FFA	See P.105
Tip adapter (Internal thread)	NFA	See P.109
Tip adapter (Keyway)	KFA	See P.108
Non-motor end specification	NM	See P.110

Actuator Specifications

Item	Description
Drive system	Ball screw ø12mm, rolled C10
Positioning repeatability	±0.01mm
Lost motion	0.1mm or less
Rod	ø30mm Aluminum
Rod non-rotation precision (*)	0 deg.
Allowable load and torque on rod tip	See P. 127
Rod tip offset/overhang distance	dx/dz: 150mm or less
Ambient operating temp. & humidity	0~40°C, 85% RH or less (Non-condensing)

(*) Rod's angular displacement in rotational direction with no load applied to the rod.

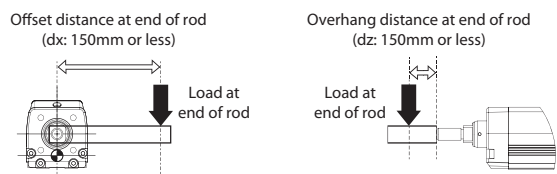

Dimensions

CAD drawings can be downloaded from our website.
www.robocylinder.de



- *1 When the rod is returning to its home position, please be careful of interference from surrounding objects, as it will travel until it reaches the M.E. M.E: Mechanical end S.E: Stroke end
- *2 The direction of width across flats varies depending on the product.
- *3 When fixing the actuator using a front bracket or flange, please make sure that there is no external force applied to the main body.

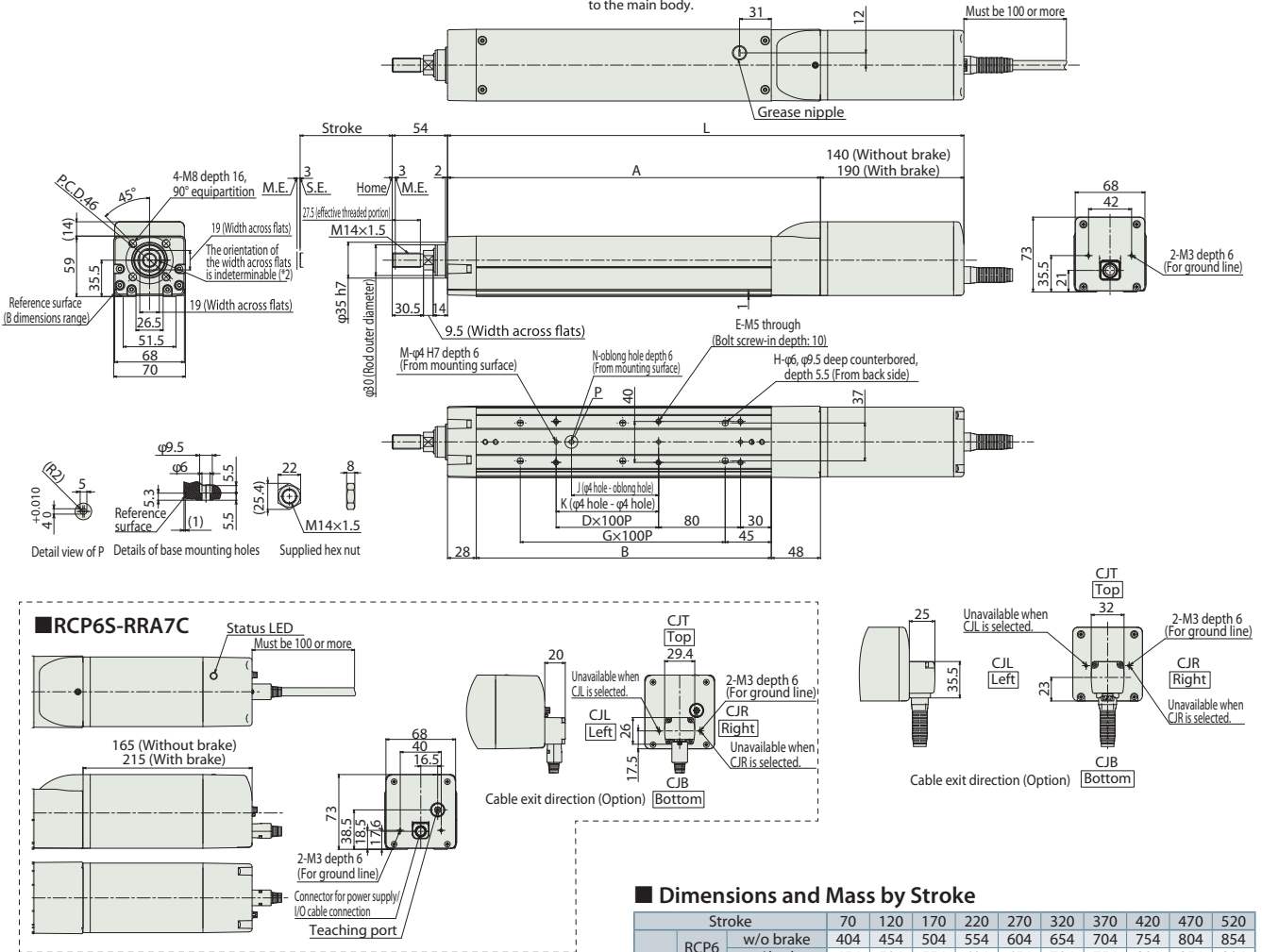

Dimensions and Mass by Stroke

		Stroke	70	120	170	220	270	320	370	420	470	520
L	RCP6	w/o brake	404	454	504	554	604	654	704	754	804	854
		w/ brake	454	504	554	604	654	704	754	804	854	904
	RCP6S	w/o brake	429	479	529	579	629	679	729	779	829	879
		w/ brake	479	529	579	629	679	729	779	829	879	929
A			264	314	364	414	464	514	564	614	664	714
B			188	238	288	338	388	438	488	538	588	638
D			0	1	1	2	2	3	3	4	4	5
E			4	6	6	8	8	10	10	12	12	14
G			1	1	2	2	3	3	4	4	5	5
H			4	4	6	6	8	8	10	10	12	12
J			0	85	85	185	185	285	285	385	385	485
K			0	0	100	200	200	300	300	400	400	500
M			2	2	3	3	3	3	3	3	3	3
N			0	1	1	1	1	1	1	1	1	1
Allowable static load on rod tip (N)			175	147	126	111	98.6	88.7	80.6	73.8	68	63
Allowable dynamic Load offset 0mm			7.7	6.4	5.4	4.7	4.1	3.7	3.3	3.0	2.7	2.5
load on rod tip (kg) Load offset 100mm			5.1	4.6	4.1	3.7	3.4	3.1	2.8	2.6	2.4	2.2
Allowable static torque on rod tip (N-m)			17.6	14.7	12.7	11.2	9.9	9.0	8.2	7.5	6.94	6.45
Allowable dynamic torque on rod tip (N-m)			5.0	4.5	4.0	3.6	3.3	3.0	2.8	2.5	2.32	2.16
Mass (kg)	RCP6	w/o brake	4.0	4.3	4.6	4.8	5.1	5.4	5.7	5.9	6.2	6.5
		w/ brake	4.4	4.7	5.0	5.3	5.5	5.8	6.1	6.4	6.7	6.9
	RCP6S	w/o brake	4.2	4.5	4.7	5.0	5.3	5.6	5.8	6.1	6.4	6.7
		w/ brake	4.6	4.9	5.2	5.5	5.7	6.0	6.3	6.6	6.8	7.1

Rod Deflection of RCP6(S)-RRA7C (Reference Values)

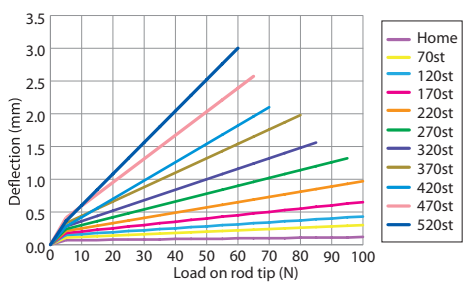

Applicable Controllers

The RCP6 series actuators can be operated by the controllers indicated below. Please select the type depending on your intended use. * Please refer to P.147 for more information about the built-in controller of RCP6S series.

Name	External view	Max. number of controlled axes	Input power	Control method				Maximum number of positioning points	Reference page
				Positioner	Pulse train	Program	Network *Option		
PCON-CB/CGB		1	DC24V	● *Option	● *Option	-	DeviceNet CC-Link EtherCAT EtherNet/IP CompoNet	512 (768 for network spec.)	Please see P.132
MCON-C/CG		4		This model is network-compatible only.					
MSEL-PC/PG		4	Single-phase 100~230VAC	-	-	●	Note: The type of compatible networks will vary depending on the controller. Please refer to reference page for more information.	30000	Please see the MSEL-PC/PG catalog or manual.

* Please select "high-output specification" as an option for the MCON. With the MCON, operation is possible only when the high-output specification is selected.

RCP6(S)-RRA8C

Battery-less Absolute
Motor Unit Coupled
Straight Motor
Body Width 85 mm
24v Pulse Motor

Model Specification Items	Series	Type	Encoder Type	Motor Type	Lead	Stroke	Applicable Controller/I/O Type	Cable Length	Options
	RCP6	RRA8C	WA	60P					
	RCP6S								
	RCP6: Separate Controller RCP6S: Built-in Controller		WA: Battery-less Absolute	60P: Pulse Motor 60□ Size	20: 20mm 10: 10mm 5: 5mm	50: 50mm 70: 700mm (50mm increments)	[RCP6] P4: PCON- CFB/CGFB [RCP6S] SE: SIO Type	N : None P : 1m S : 3m M : 5m X□□ : Specified Length R□□ : Robot Cable	Please refer to the options table below.

* RCP6 does not include a controller. RCP6S includes a built-in controller.

Radial Load OK

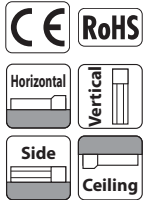

*Depending on the model, there may be some limitations to using the vertical, side, and ceiling mount positions. Please contact IAI for more information regarding mounting positions.



- The maximum acceleration/deceleration is 0.1G for lead 5 and 0.2G for lead 10/20.
- The actuator specification displays the payload's maximum value, but it will vary depending on the acceleration and speed. Please refer to the "Selection Guidelines" (RCP6 Tables of Payload by Speed/Acceleration) on P.115 for more details.
- The radial cylinder is equipped with a built-in guide. Please refer to the graphs shown in P.127 and after for the allowable load mass.
- When performing push-motion operation, please confirm the push force of each model by checking the "Correlation diagram of push force and current limit" on P.113.
- For RCP6S (built-in controller type), please limit the duty cycle to 70% or less.
- The service life of an actuator varies depending on the payload when using vertically. Please refer to P. 114 for more information.

Correlation Diagrams of Speed and Payload

PCON connected.

RCP6(S)-RRA8C Horizontal mount

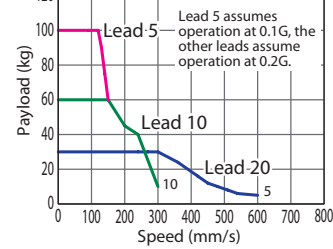

RCP6(S)-RRA8C Vertical mount

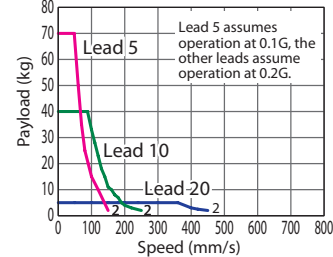

Actuator Specifications

Lead and Payload

(**) The payload assumes that there is an external guide.

Model Number	Lead (mm)	Max. Payload		Stroke (mm)
		Horizontal (kg)**	Vertical (kg)	
RCP6(S)-RRA8C-WA-60P-20-①-②-③-④	20	30	5	50~700 (The increment of stroke is 50mm)
RCP6(S)-RRA8C-WA-60P-10-①-②-③-④	10	60	40	
RCP6(S)-RRA8C-WA-60P-5-①-②-③-④	5	100	70	

Legend: ① Stroke ② Applicable controller/I/O type ③ Cable length ④ Options

Stroke and Max. Speed

(Unit: mm/s)

Lead (mm)	50 (mm)	100 (mm)	150 (mm)	200 (mm)	250~350 (mm)	400 (mm)	450 (mm)	500 (mm)	550 (mm)	600 (mm)	650 (mm)	700 (mm)
20	280	405	505 <450>	585 <450>	600 <450>	520 <450>	440	360	320	280	240	220
10	280 <250>		300 <250>			260 <250>	220	180	160	140	120	110
5			150			130	110	90	80	70	60	55

Values in brackets < > are for vertical use.

Cable Length

Cable Type	Cable Code
Standard	P (1m)
	S (3m)
	M (5m)
Specified Length	X06 (6m) ~ X10 (10m)
	X11 (11m) ~ X15 (15m)
	X16 (16m) ~ X20 (20m)
	R01 (1m) ~ R03 (3m)
Robot Cable	R04 (4m) ~ R05 (5m)
	R06 (6m) ~ R10 (10m)
	R11 (11m) ~ R15 (15m)
	R16 (16m) ~ R20 (20m)
	R16 (16m) ~ R20 (20m)

* Refer to P.144 for more information regarding the maintenance cables.

Options

Name	Option Code	Reference Page
Brake	B	See P.105
Cable exit direction (Top)	CJT	See P.105
Cable exit direction (Right)	CJR	See P.105
Cable exit direction (Left)	CJL	See P.105
Cable exit direction (Bottom)	CJB	See P.105
Flange	FL	See P.106
Tip adapter (Internal thread)	NFA	See P.109
Non-motor end specification	NM	See P.110

Actuator Specifications

Item	Description
Drive system	Ball screw ø16mm, rolled C10
Positioning repeatability	±0.01mm
Lost motion	0.1mm or less
Rod	ø40mm Aluminum
Rod non-rotation precision (*)	0 deg.
Allowable load and torque on rod tip	See P. 127
Rod tip offset/overhang distance	dx/dz: 150mm or less
Ambient operating temp. & humidity	0~40°C, 85% RH or less (Non-condensing)

(*) Rod's angular displacement in rotational direction with no load applied to the rod.

Offset distance at end of rod (dx: 150mm or less)

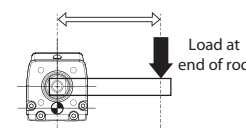

Overhang distance at end of rod (dz: 150mm or less)

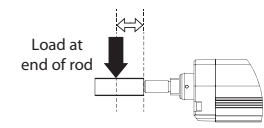

Dimensions

CAD drawings can be downloaded from our website.
www.robocylinder.de



- *1 When the rod is returning to its home position, please be careful of interference from surrounding objects, as it will travel until it reaches the M.E. M.E: Mechanical end S.E: Stroke end
- *2 The direction of width across flats varies depending on the product.
- *3 When fixing the actuator using a front bracket or flange, please make sure that there is no external force applied to the main body.

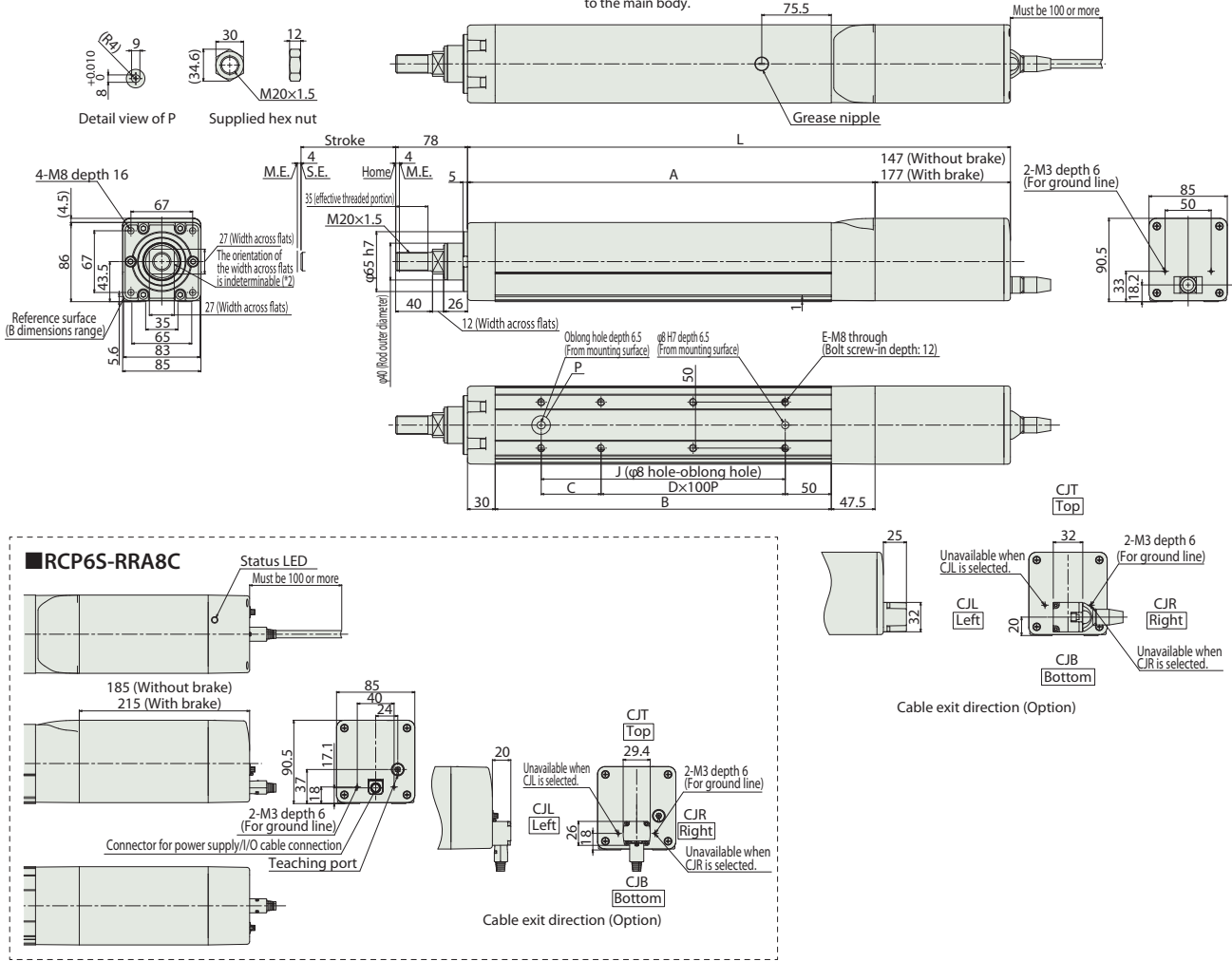

■ Rod Deflection of RCP6(S)-RRR8C (Reference Values)

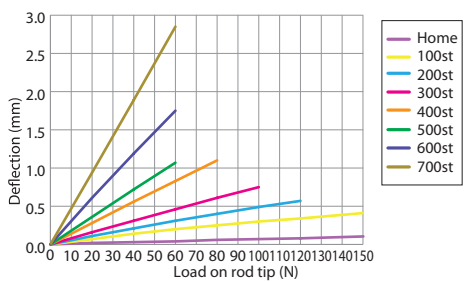

■ Dimensions and Mass by Stroke

L	Stroke	Stroke														
		50	100	150	200	250	300	350	400	450	500	550	600	650	700	
RCP6	w/o brake	439.5	489.5	539.5	589.5	639.5	689.5	739.5	789.5	839.5	889.5	939.5	989.5	1039.5	1089.5	
	w/ brake	469.5	519.5	569.5	619.5	669.5	719.5	769.5	819.5	869.5	919.5	969.5	1019.5	1069.5	1119.5	
RCP6S	w/o brake	477.5	527.5	577.5	627.5	677.5	727.5	777.5	827.5	877.5	927.5	977.5	1027.5	1077.5	1127.5	
	w/ brake	507.5	557.5	607.5	657.5	707.5	757.5	807.5	857.5	907.5	957.5	1007.5	1057.5	1107.5	1157.5	
A		292.5	342.5	392.5	442.5	492.5	542.5	592.5	642.5	692.5	742.5	792.5	842.5	892.5	942.5	
	B	215	265	315	365	415	465	515	565	615	665	715	765	815	865	
C		115	65	115	65	115	65	115	65	115	65	115	65	115	65	
	D	0	1	1	2	2	3	3	4	4	5	5	6	6	7	
E		4	6	6	8	8	10	10	12	12	14	14	16	16	18	
	J	115	165	215	265	315	365	415	465	515	565	615	665	715	765	
Allowable static load on rod tip (N)		222	186	159	139	124	111	101	92.1	84.7	78.4	72.8	68	63.7	59.8	
	load on rod tip (kg) Load offset 0mm	9.5	7.8	6.6	5.7	5.0	4.5	4.0	3.6	3.3	3.0	2.8	2.6	2.4	2.2	
Allowable static torque on rod tip (N·m)		7.4	6.3	5.5	4.9	4.4	4.0	3.6	3.3	3.0	2.8	2.6	2.4	2.2	2.1	
	Allowable dynamic torque on rod tip (N·m)	22.3	18.7	16.1	14.1	12.6	11.3	10.3	9.4	8.7	8.1	7.6	7.1	6.7	6.3	
Mass (kg)	RCP6	w/o brake	7.2	6.2	5.4	4.8	4.3	3.9	3.5	3.2	3.0	2.7	2.5	2.4	2.2	2.0
		w/ brake	6.6	7.1	7.6	8.0	8.5	9.0	9.5	9.9	10.4	10.9	11.4	11.8	12.3	12.8
	RCP6S	w/o brake	7.2	7.7	8.2	8.6	9.1	9.6	10.1	10.5	11.0	11.5	11.9	12.4	12.9	13.4
		w/ brake	7.0	7.4	7.9	8.4	8.8	9.3	9.8	10.3	10.7	11.2	11.7	12.1	12.6	13.1

Applicable Controllers

The RCP6 series actuators can be operated by the controllers indicated below. Please select the type depending on your intended use. * Please refer to P.147 for more information about the built-in controller of RCP6S series.

Name	External view	Max. number of controlled axes	Input power	Positioner	Pulse train	Program	Control method		Maximum number of positioning points	Reference page	
							Network *Option				
PCON-CFB/CGFB		1	DC24V	*Option	*Option	-	DeviceNet	CompoNet	EtherNet/IP	512 (768 for network spec.)	Please see P.132

RCP6(S)-RRA4R

Battery-less Absolute
Motor Unit Coupled
Side-mounted Motor
Body Width 40* mm
24v Pulse Motor

Model Specification Items	Series	Type	Encoder Type	Motor Type	Lead	Stroke	Applicable Controller/I/O Type	Cable Length	Options
	RCP6	RRA4R	WA	35P					
	RCP6S								
	RCP6: Separate Controller RCP6S: Built-in Controller		WA: Battery-less Absolute	35P: Pulse Motor 35□ Size	16: 16mm 10: 10mm 5: 5mm 2.5: 2.5mm	60: 60mm ? 410: 410mm (50mm increments)	[RCP6] P3: PCON MCON MSEL [RCP6S] SE: SIO Type	N : None P : 1m S : 3m M : 5m X□ : Specified Length R□ : Robot Cable	Please refer to the options table below. *Please make sure to specify either ML or MR when ordering the side-mounted motor type.

* RCP6 does not include a controller. RCP6S includes a built-in controller.

* Body width does not include the width of the side-mounted motor.

Radial Load OK

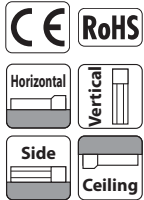

*Depending on the model, there may be some limitations to using the vertical, side, and ceiling mount positions. Please contact IAI for more information regarding mounting positions.

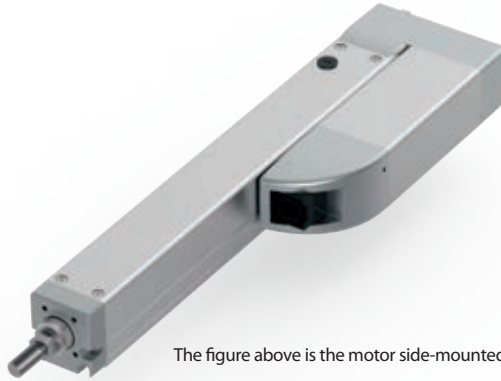

The figure above is the motor side-mounted to the left (ML).

- POINT Selection Notes**
- (1) The maximum acceleration/deceleration is 1G for horizontal, and 0.5G for vertical use.
 - (2) The actuator specification displays the payload's maximum value, but it will vary depending on the acceleration and speed. Please refer to the "Selection Guidelines" (RCP6 Tables of Payload by Speed/Acceleration) on P.115 for more details.
 - (3) The radial cylinder is equipped with a built-in guide. Please refer to the graphs shown in P.127 and after for the allowable load mass.
 - (4) When performing push-motion operation, please confirm the push force of each model by checking the "Correlation diagram of push force and current limit" on P.113.

Correlation Diagrams of Speed and Payload

High-output enabled (*) with PCON/MCON/MSEL connected.
RCP6(S)-RRA4R Horizontal mount

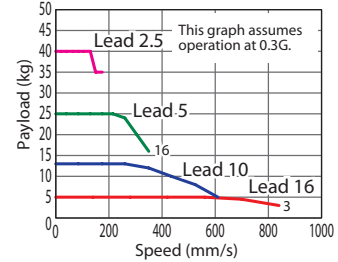

RCP6(S)-RRA4R Vertical mount

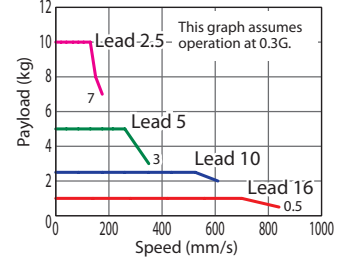

(*) For high output setting to OFF refer to the RCP6 manual.

Actuator Specifications (*)

(*) For values of disabled high output controller setting refer to the RCP6 manual.

Lead and Payload

(**) The payload assumes that there is an external guide.

Model Number	Lead (mm)	Connected Controller	Max. Payload		Stroke (mm)
			Horizontal (kg) (**)	Vertical (kg)	
RCP6(S)-RRA4R-WA-35P-16-①-②-③-④	16	High-output Enabled	5	1	60~410 (The increment of stroke is 50mm)
RCP6(S)-RRA4R-WA-35P-10-①-②-③-④	10	High-output Enabled	13	2.5	
RCP6(S)-RRA4R-WA-35P-5-①-②-③-④	5	High-output Enabled	28	5	
RCP6(S)-RRA4R-WA-35P-2.5-①-②-③-④	2.5	High-output Enabled	40	10	

Stroke and Max. Speed

(Unit: mm/s)

Lead (mm)	Connected Controller	60~360 (Every 50mm)		410 (mm)
		60~360 (Every 50mm)	410 (mm)	
16	High-output Enabled	840		
10	High-output Enabled	610		
5	High-output Enabled	350	340	
2.5	High-output Enabled	175	170	

Legend: ① Stroke ② Applicable controller/I/O type ③ Cable length ④ Options

Cable Length

Cable Type	Cable Code
Standard	P (1m)
	S (3m)
	M (5m)
Specified Length	X06 (6m) ~ X10 (10m)
	X11 (11m) ~ X15 (15m)
	X16 (16m) ~ X20 (20m)
	R01 (1m) ~ R03 (3m)
Robot Cable	R04 (4m) ~ R05 (5m)
	R06 (6m) ~ R10 (10m)
	R11 (11m) ~ R15 (15m)
	R16 (16m) ~ R20 (20m)

* Refer to P.144 for more information regarding the maintenance cables.

Options

Name	Option Code	Reference Page
Brake	B	See P.105
Cable exit direction (Outside)	CJO	See P.105
Flange	FL	See P.106
Tip adapter (Flange)	FFA	See P.105
Tip adapter (Internal thread)	NFA	See P.109
Tip adapter (Keyway)	KFA	See P.108
Motor side-mounted to the left	ML	See P.109
Motor side-mounted to the right	MR	See P.109
Knuckle joint (*)	NJ	See P.110
Non-motor end specification	NM	See P.110
Clevis bracket (*)	QR	See P.111

Actuator Specifications

Item	Description
Drive system	Ball screw ø8mm, rolled C10
Positioning repeatability	±0.01mm
Lost motion	0.1mm or less
Rod	ø20mm Aluminum
Rod non-rotation precision (*)	0 deg.
Allowable load and torque on rod tip	See P.127
Rod tip offset/overhang distance	dx/dz: 100mm or less
Ambient operating temp. & humidity	0~40°C, 85% RH or less (Non-condensing)

(*) Rod's angular displacement in rotational direction with no load applied to the rod.

Offset distance at end of rod (dx: 100mm or less)

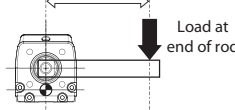

Overhang distance at end of rod (dz: 100mm or less)

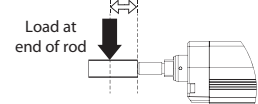

(*) The clevis (QR) and knuckle joint (NJ) are sold as a set. The assembly is to be performed by the customer.

Dimensions

CAD drawings can be downloaded from our website.
www.robocylinder.de



- *1 When the rod is returning to its home position, please be careful of interference from surrounding objects, as it will travel until it reaches the M.E. M.E: Mechanical end S.E: Stroke end
- *2 The direction of width across flats varies depending on the product.
- *3 When fixing the actuator using a front bracket or flange, please make sure that there is no external force applied to the main body.

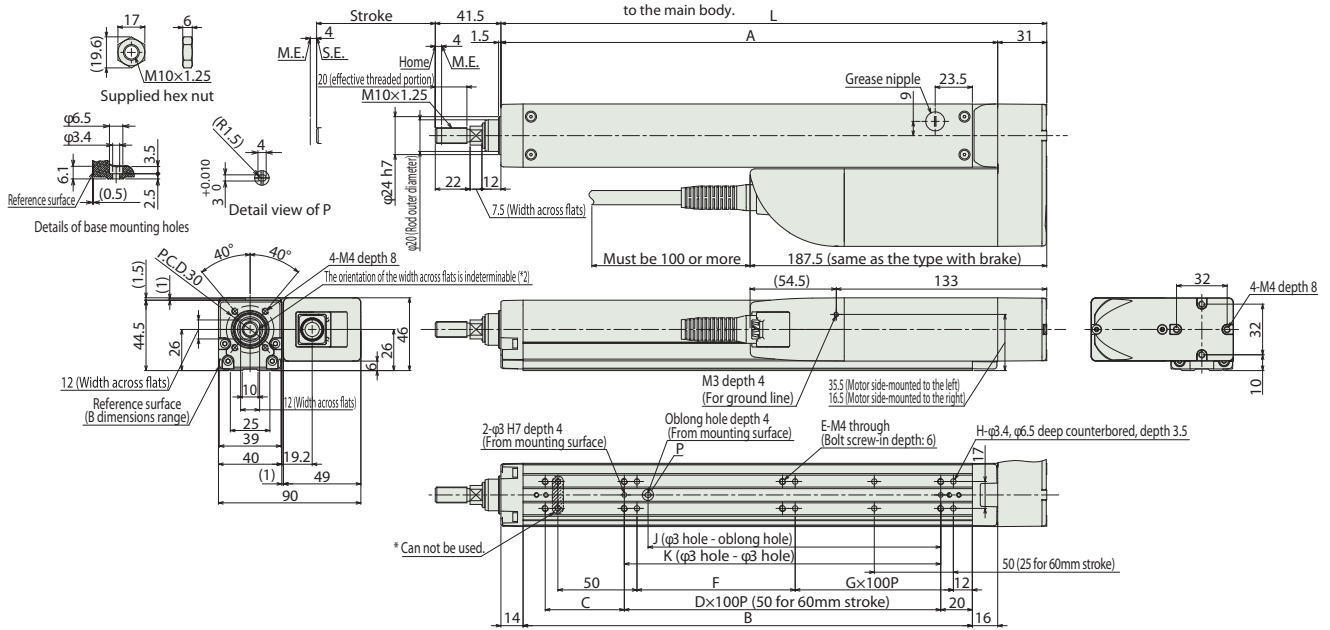

RCP6S-RR4R

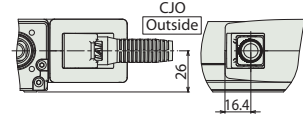
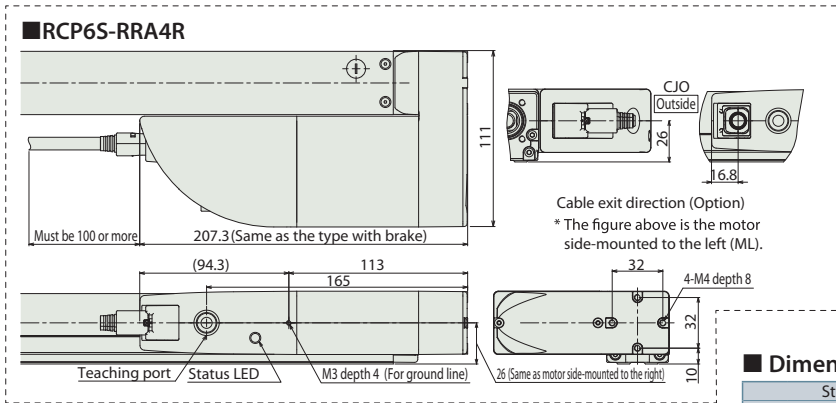

* The two mounting holes (H) on the rod side of the top surface of the base can not be used. The number of the holes (H) in the table does not include these holes that cannot be used.

Dimensions and Mass by Stroke

Stroke	60	110	160	210	260	310	360	410		
L	195	245	295	345	395	445	495	545		
A	164	214	264	314	364	414	464	514		
B	134	184	234	284	334	384	434	484		
C	50	50	100	50	100	50	100	50		
D	0	1	2	2	3	3	3	4		
E	6	6	6	8	8	10	10	12		
F	50	100	50	100	50	100	50	100		
G	0	0	1	1	2	2	3	3		
H	6	6	8	8	10	10	12	12		
J	35	85	85	185	185	285	285	385		
K	50	100	100	200	200	300	300	400		
Allowable static load on rod tip (N)	63.4	50.7	42.1	36	31.3	27.6	24.6	22.2		
Allowable dynamic Load offset 0mm	2.9	2.3	1.8	1.5	1.3	1.1	1.0	0.8		
load on rod tip (kg) Load offset 100mm	1.8	1.6	1.4	1.2	1.0	0.9	0.8	0.7		
Allowable static torque on rod tip (N·m)	6.4	5.1	4.3	3.7	3.2	2.9	2.6	2.3		
Allowable dynamic torque on rod tip (N·m)	1.7	1.5	1.3	1.1	1.0	0.9	0.7	0.7		
Mass (kg)	RCP6	w/o brake	1.4	1.5	1.6	1.8	1.9	2.0	2.1	2.3
		w/ brake	1.4	1.6	1.7	1.8	1.9	2.1	2.2	2.3
	RCP6S	w/o brake	1.5	1.6	1.8	1.9	2.0	2.1	2.3	2.4
		w/ brake	1.6	1.7	1.8	1.9	2.1	2.2	2.3	2.4

Rod Deflection of RCP6(S)-RR4R (Reference Values)

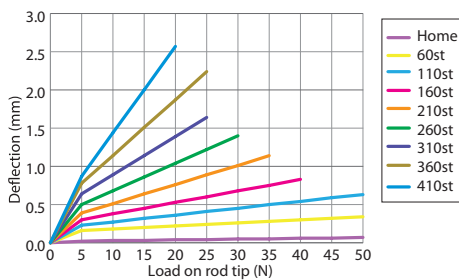

Applicable Controllers

The RCP6 series actuators can be operated by the controllers indicated below. Please select the type depending on your intended use. * Please refer to P.147 for more information about the built-in controller of RCP6S series.

Name	External view	Max. number of controlled axes	Input power	Control method				Maximum number of positioning points	Reference page
				Positioner	Pulse train	Program	Network *Option		
PCON-CB/CGB		1	DC24V	● *Option	● *Option	-		512 (768 for network spec.)	Please see P.132
MCON-C/CG		4		This model is network-compatible only.				256	Please see the MCON catalog or manual.
MSEL-PC/PG		4	Single-phase 100~230VAC	-	-	●	Note: The type of compatible networks will vary depending on the controller. Please refer to reference page for more information.	30000	Please see the MSEL-PC/PG catalog or manual.

* Please select "high-output specification" as an option for the MCON. With the MCON, operation is possible only when the high-output specification is selected.

RCP6(S)-RRA6R

Battery-less Absolute
Motor Unit Coupled
Side-mounted Motor
Body Width 58* mm
24v Pulse Motor

Model Specification Items	Series	Type	Encoder Type	Motor Type	Lead	Stroke	Applicable Controller/I/O Type	Cable Length	Options
	RCP6: Separate Controller RCP6S: Built-in Controller	RRA6R	WA	42P	20: 20mm 12: 12mm 6: 6mm 3: 3mm	65: 65mm 12: 12mm 6: 6mm 3: 3mm	[RCP6] P3: PCON MCON MSEL [RCP6S] SE: SIO Type	N : None P : 1m S : 3m M : 5m X□ : Specified Length R□ : Robot Cable	Please refer to the options table below. *Please make sure to specify either ML or MR when ordering the side-mounted motor type.

* RCP6 does not include a controller. RCP6S includes a built-in controller.

* Body width does not include the width of the side-mounted motor.

Radial Load OK

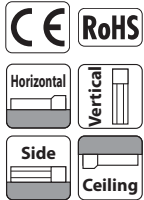

*Depending on the model, there may be some limitations to using the vertical, side, and ceiling mount positions. Please contact IAI for more information regarding mounting positions.



The figure above is the motor side-mounted to the left (ML).



- (1) The maximum acceleration/deceleration is 1G for horizontal, and 0.5G for vertical use.
- (2) The actuator specification displays the payload's maximum value, but it will vary depending on the acceleration and speed. Please refer to the "Selection Guidelines" (RCP6 Tables of Payload by Speed/Acceleration) on P.115 for more details.
- (3) The radial cylinder is equipped with a built-in guide. Please refer to the graphs shown in P.127 and after for the allowable load mass.
- (4) When performing push-motion operation, please confirm the push force of each model by checking the "Correlation diagram of push force and current limit" on P.113.
- (5) Depending on the ambient operational temperature, duty control is necessary for the RCP6S (built-in controller type) with lead 3/6. Please refer to P.130 for more information.

Correlation Diagrams of Speed and Payload

High-output enabled (*) with PCON/MCON/MSEL connected.
RCP6(S)-RRA6R Horizontal mount

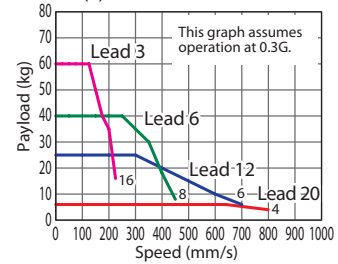

RCP6(S)-RRA6R Vertical mount

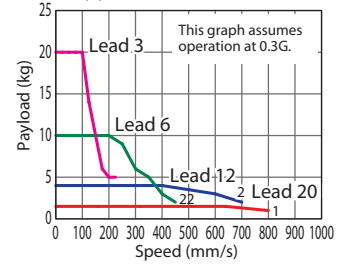

(*) For high output setting to OFF refer to the RCP6 manual.

Actuator Specifications (*)

(*) For values of disabled high output controller setting refer to the RCP6 manual.

Lead and Payload

(**) The payload assumes that there is an external guide.

Model Number	Lead (mm)	Connected Controller	Max. Payload		Stroke (mm)
			Horizontal (kg)**	Vertical (kg)	
RCP6(S)-RRA6R-WA-42P-20-①-②-③-④	20	High-output Enabled	6	1.5	65~415 (The increment of stroke is 50mm)
RCP6(S)-RRA6R-WA-42P-12-①-②-③-④	12	High-output Enabled	25	4	
RCP6(S)-RRA6R-WA-42P-6-①-②-③-④	6	High-output Enabled	40	10	
RCP6(S)-RRA6R-WA-42P-3-①-②-③-④	3	High-output Enabled	60	20	

Stroke and Max. Speed

(Unit: mm/s)

Lead (mm)	Connected Controller	65~365 (Every 50mm)		415 (mm)
		65~365 (Every 50mm)	415 (mm)	
20	High-output Enabled	800		
12	High-output Enabled	700		
6	High-output Enabled	450		
3	High-output Enabled	225	220	

Legend: ① Stroke ② Applicable controller/I/O type ③ Cable length ④ Options

Cable Length

Cable Type	Cable Code
Standard	P (1m)
	S (3m)
	M (5m)
Specified Length	X06 (6m) ~ X10 (10m)
	X11 (11m) ~ X15 (15m)
	X16 (16m) ~ X20 (20m)
	R01 (1m) ~ R03 (3m)
Robot Cable	R04 (4m) ~ R05 (5m)
	R06 (6m) ~ R10 (10m)
	R11 (11m) ~ R15 (15m)
	R16 (16m) ~ R20 (20m)
	R16 (16m) ~ R20 (20m)

* Refer to P.144 for more information regarding the maintenance cables.

Options

Name	Option Code	Reference Page
Brake	B	See P.105
Cable exit direction (Outside)	CJO	See P.105
Flange	FL	See P.106
Tip adapter (Flange)	FFA	See P.105
Tip adapter (Internal thread)	NFA	See P.109
Tip adapter (Keyway)	KFA	See P.108
Motor side-mounted to the left	ML	See P.109
Motor side-mounted to the right	MR	See P.109
Knuckle joint (*)	NJ	See P.110
Non-motor end specification	NM	See P.110
Clevis bracket (*)	QR	See P.111

(*) The clevis (QR) and knuckle joint (NJ) are sold as a set. The assembly is to be performed by the customer.

Actuator Specifications

Item	Description
Drive system	Ball screw ø10mm, rolled C10
Positioning repeatability	±0.01mm
Lost motion	0.1mm or less
Rod	ø25mm Aluminum
Rod non-rotation precision (*)	0 deg.
Allowable load and torque on rod tip	See P. 127
Rod tip offset/overhang distance	dx/dz: 100mm or less
Ambient operating temp. & humidity	0~40°C, 85% RH or less (Non-condensing)

(*) Rod's angular displacement in rotational direction with no load applied to the rod.

Offset distance at end of rod (dx: 100mm or less)

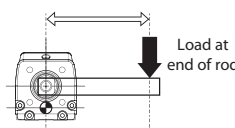

Overhang distance at end of rod (dz: 100mm or less)

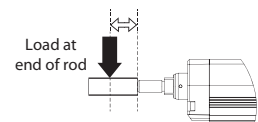

Dimensions

CAD drawings can be downloaded from our website.
www.robocylinder.de



- *1 When the rod is returning to its home position, please be careful of interference from surrounding objects, as it will travel until it reaches the M.E. M.E: Mechanical end S.E: Stroke end
- *2 The direction of width across flats varies depending on the product.
- *3 When fixing the actuator using a front bracket or flange, please make sure that there is no external force applied to the main body.

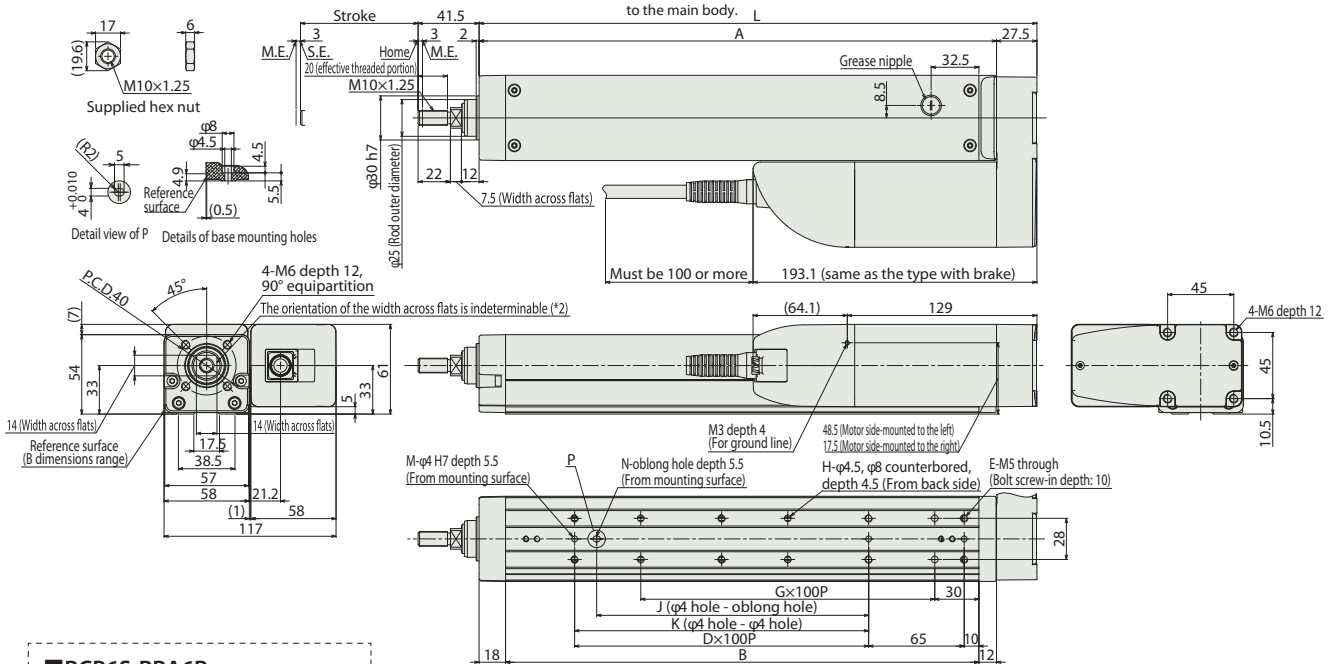

RCP6S-RRR6R

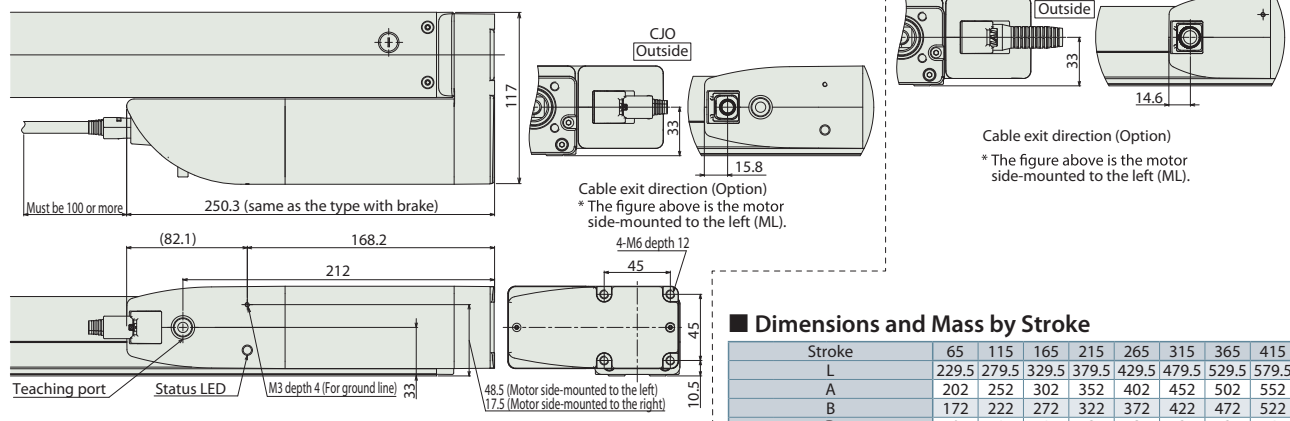

Rod Deflection of RCP6(S)-RRR6R (Reference Values)

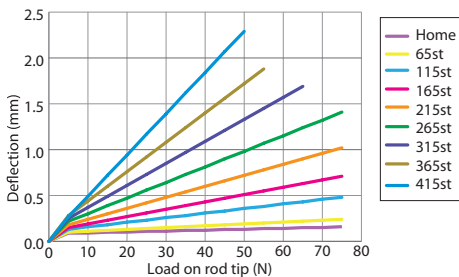

Dimensions and Mass by Stroke

Stroke	65	115	165	215	265	315	365	415	
L	229.5	279.5	329.5	379.5	429.5	479.5	529.5	579.5	
A	202	252	302	352	402	452	502	552	
B	172	222	272	322	372	422	472	522	
D	0	1	1	2	2	3	3	4	
E	4	6	6	8	8	10	10	12	
G	1	1	2	2	3	3	4	4	
H	4	4	6	6	8	8	10	10	
J	0	85	85	185	185	285	285	385	
K	0	100	100	200	200	300	300	400	
M	2	3	3	3	3	3	3	3	
N	0	1	1	1	1	1	1	1	
Allowable static load on rod tip (N)	144	117	99	85.4	75	66.7	59.9	54.3	
Allowable dynamic Load offset 0mm	5.9	4.7	3.9	3.3	2.8	2.5	2.2	2.0	
load on rod tip (kg) Load offset 100mm	4.0	3.5	3.0	2.7	2.4	2.1	1.9	1.7	
Allowable static torque on rod tip (N·m)	14.5	11.8	10.0	8.7	7.6	6.8	6.2	5.6	
Allowable dynamic torque on rod tip (N·m)	3.8	3.3	2.9	2.6	2.3	2.0	1.8	1.6	
Mass (kg)	RCP6	w/o brake	2.4	2.6	2.9	3.1	3.3	3.5	3.8
		w/ brake	2.5	2.7	2.9	3.2	3.4	3.6	3.8
	RCP6S	w/o brake	2.6	2.8	3.0	3.2	3.4	3.7	3.9
		w/ brake	2.6	2.8	3.1	3.3	3.5	3.7	4.0

Applicable Controllers

The RCP6 series actuators can be operated by the controllers indicated below. Please select the type depending on your intended use. * Please refer to P.147 for more information about the built-in controller of RCP6S series.

Name	External view	Max. number of controlled axes	Input power	Control method				Maximum number of positioning points	Reference page
				Positioner	Pulse train	Program	Network *Option		
PCON-CB/CGB		1	DC24V	● *Option	● *Option	-	 	512 (768 for network spec.)	Please see P.132
MCON-C/CG		4		This model is network-compatible only.				 	256
MSEL-PC/PG		4	Single-phase 100~230VAC	-	-	●	Note: The type of compatible networks will vary depending on the controller. Please refer to reference page for more information.	30000	Please see the MSEL-PC/PG catalog or manual.

* Please select "high-output specification" as an option for the MCON. With the MCON, operation is possible only when the high-output specification is selected.

RCP6(S)-RRA7R

Battery-less Absolute
Motor Unit Coupled
Side-mounted Motor
Body Width 70* mm
24v Pulse Motor

Model Specification Items	Series	Type	Encoder Type	Motor Type	Lead	Stroke	Applicable Controller/I/O Type	Cable Length	Options
	RRA7R	WA	56P						
	RCP6: Separate Controller RCP6S: Built-in Controller		WA: Battery-less Absolute	56P: Pulse Motor 56□ Size	24: 24mm 16: 16mm 8: 8mm 4: 4mm	70: 70mm ? 520: 520mm (50mm increments)	[RCP6] P3: PCON MCON MSEL [RCP6S] SE: SIO Type	N : None P : 1m S : 3m M : 5m X□□ : Specified Length R□□ : Robot Cable	*Body width does not include the width of the side-mounted motor. Please refer to the options table below. *Please make sure to specify either ML or MR when ordering the side-mounted motor type.

* RCP6 does not include a controller. RCP6S includes a built-in controller.

Radial Load OK

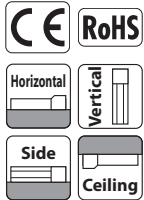

*Depending on the model, there may be some limitations to using the vertical, side, and ceiling mount positions. Please contact IAI for more information regarding mounting positions.

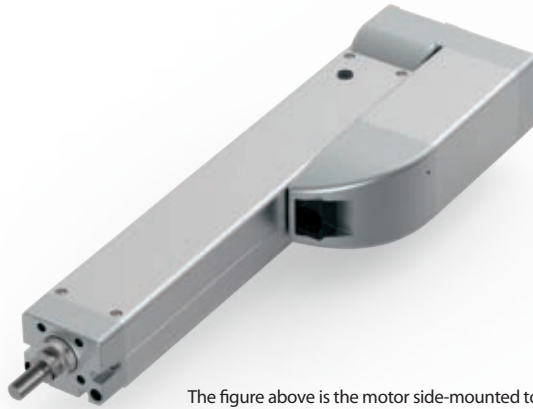

The figure above is the motor side-mounted to the left (ML).



- (1) The maximum acceleration/deceleration is 1G for horizontal, and 0.5G for vertical use.
- (2) The actuator specification displays the payload's maximum value, but it will vary depending on the acceleration and speed. Please refer to the "Selection Guidelines" (RCP6 Tables of Payload by Speed/Acceleration) on P.115 for more details.
- (3) The radial cylinder is equipped with a built-in guide. Please refer to the graphs shown in P.127 and after for the allowable load mass.
- (4) When performing push-motion operation, please confirm the push force of each model by checking the "Correlation diagram of push force and current limit" on P.113.
- (5) Depending on the ambient operational temperature, duty control is necessary for the RCP6S (built-in controller type) with lead 4/8/16. Please refer to P.130 for more information.

Correlation Diagrams of Speed and Payload

High-output enabled (*) with PCON/MCON/MSEL connected.
RCP6(S)-RRA7R Horizontal mount

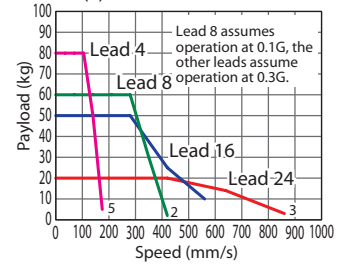

RCP6(S)-RRA7R Vertical mount

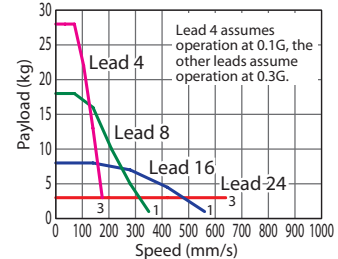

(*) For high output setting to OFF refer to the RCP6 manual.

Actuator Specifications (*)

(*) For values of disabled high output controller setting refer to the RCP6 manual.

Lead and Payload

(**) The payload assumes that there is an external guide.

Model Number	Lead (mm)	Connected Controller	Max. Payload		Stroke (mm)
			Horizontal (kg) (*)	Vertical (kg)	
RCP6(S)-RRA7R-WA-56P-24-①-②-③-④	24	High-output Enabled	20	3	70~520 (The increment of stroke is 50mm)
RCP6(S)-RRA7R-WA-56P-16-①-②-③-④	16	High-output Enabled	50	8	
RCP6(S)-RRA7R-WA-56P-8-①-②-③-④	8	High-output Enabled	60	18	
RCP6(S)-RRA7R-WA-56P-4-①-②-③-④	4	High-output Enabled	80	28	

Stroke and Max. Speed

(Unit: mm/s)

Lead (mm)	Connected Controller	70~520 (Every 50mm)
24	High-output Enabled	860 <640>
16	High-output Enabled	560
8	High-output Enabled	420 <350>
4	High-output Enabled	175

Legend: ① Stroke ② Applicable controller/I/O type ③ Cable length ④ Options

Values in brackets < > are for vertical use.

Cable Length

Cable Type	Cable Code
Standard	P (1m)
	S (3m)
	M (5m)
Specified Length	X06 (6m) ~ X10 (10m)
	X11 (11m) ~ X15 (15m)
	X16 (16m) ~ X20 (20m)
	R01 (1m) ~ R03 (3m)
Robot Cable	R04 (4m) ~ R05 (5m)
	R06 (6m) ~ R10 (10m)
	R11 (11m) ~ R15 (15m)
	R16 (16m) ~ R20 (20m)

* Refer to P.144 for more information regarding the maintenance cables.

Options

Name	Option Code	Reference Page
Brake	B	See P.105
Cable exit direction (Outside)	CJO	See P.105
Flange	FL	See P.106
Tip adapter (Flange)	FFA	See P.105
Tip adapter (Internal thread)	NFA	See P.109
Tip adapter (Keyway)	KFA	See P.108
Motor side-mounted to the left	ML	See P.109
Motor side-mounted to the right	MR	See P.109
Knuckle joint (*)	NJ	See P.110
Non-motor end specification	NM	See P.110
Clevis bracket (*)	QR	See P.111

Actuator Specifications

Item	Description
Drive system	Ball screw ø12mm, rolled C10
Positioning repeatability	±0.01mm
Lost motion	0.1mm or less
Rod	ø30mm Aluminum
Rod non-rotation precision (*)	0 deg.
Allowable load and torque on rod tip	See P.127
Rod tip offset/overhang distance	dx/dz: 150mm or less
Ambient operating temp. & humidity	0~40°C, 85% RH or less (Non-condensing)

(*) Rod's angular displacement in rotational direction with no load applied to the rod.

Offset distance at end of rod (dx: 150mm or less)

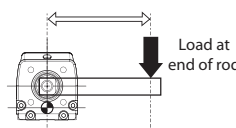

Overhang distance at end of rod (dz: 150mm or less)

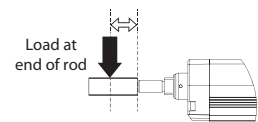

(*) The clevis (QR) and knuckle joint (NJ) are sold as a set. The assembly is to be performed by the customer.

Dimensions

CAD drawings can be downloaded from our website.
www.robocylinder.de



- *1 When the rod is returning to its home position, please be careful of interference from surrounding objects, as it will travel until it reaches the M.E. M.E: Mechanical end S.E: Stroke end
- *2 The direction of width across flats varies depending on the product.
- *3 When fixing the actuator using a front bracket or flange, please make sure that there is no external force applied to the main body.

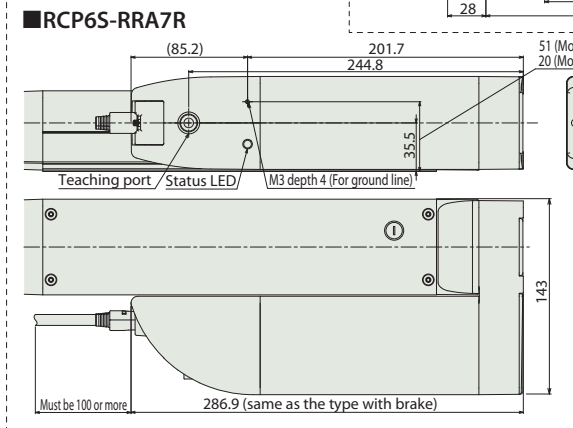
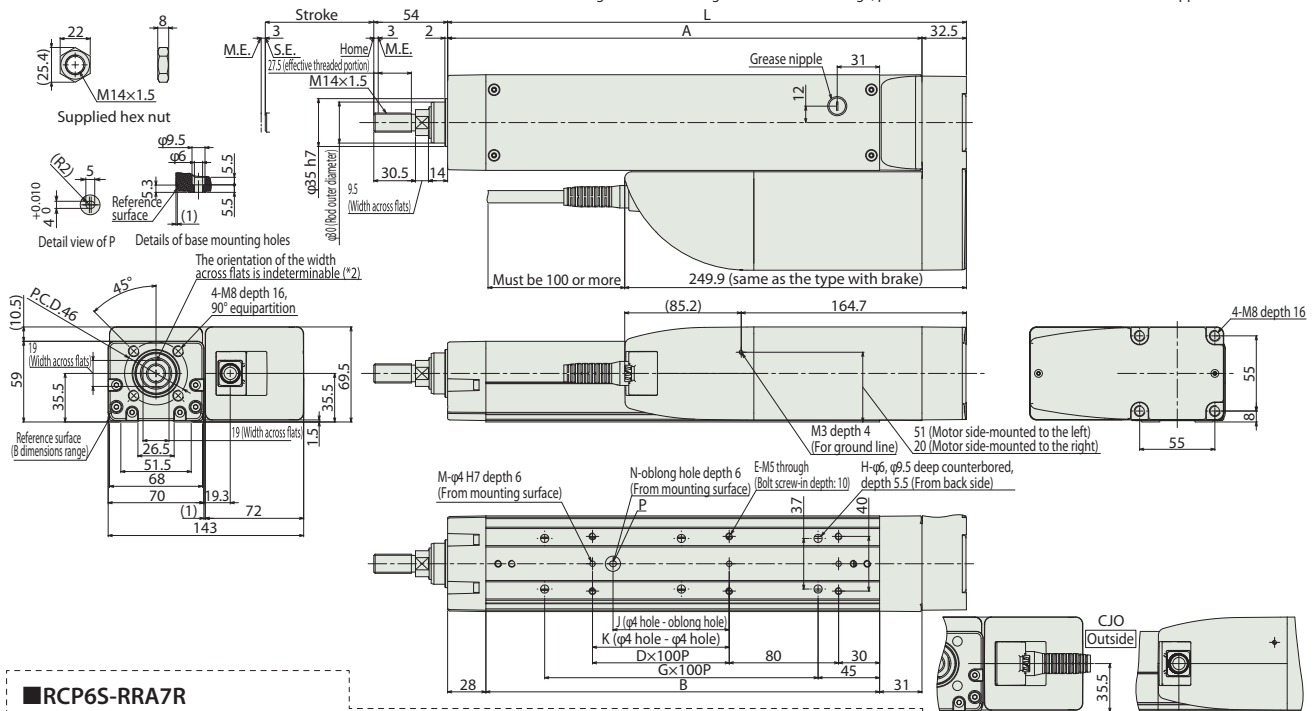

Rod Deflection of RCP6(S)-RRA7R (Reference Values)

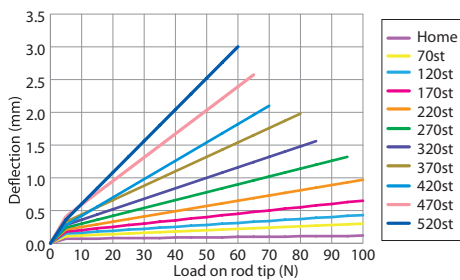

Dimensions and Mass by Stroke

Stroke	70	120	170	220	270	320	370	420	470	520	
L	279.5	329.5	379.5	429.5	479.5	529.5	579.5	629.5	679.5	729.5	
A	247	297	347	397	447	497	547	597	647	697	
B	188	238	288	338	388	438	488	538	588	638	
D	0	1	1	2	2	3	3	4	4	5	
E	4	6	6	8	8	10	10	12	12	14	
G	1	1	2	2	3	3	4	4	5	5	
H	4	4	6	6	8	8	10	10	12	12	
J	0	85	85	185	185	285	285	385	385	485	
K	0	0	100	200	200	300	300	400	400	500	
M	2	2	3	3	3	3	3	3	3	3	
N	0	1	1	1	1	1	1	1	1	1	
Allowable static load on rod tip (N)	175	147	126	111	98.6	88.7	80.6	73.8	68	63	
Allowable dynamic Load offset 0mm	7.7	6.4	5.4	4.7	4.1	3.7	3.3	3.0	2.7	2.5	
load on rod tip (kg) Load offset 100mm	5.1	4.6	4.1	3.7	3.4	3.1	2.8	2.6	2.4	2.2	
Allowable static torque on rod tip (N·m)	17.6	14.7	12.7	11.2	9.9	9.0	8.2	7.5	6.94	6.45	
Allowable dynamic torque on rod tip (N·m)	5.0	4.5	4.0	3.6	3.3	3.0	2.8	2.5	2.32	2.16	
Mass (kg)	RCP6	w/o brake	4.6	4.9	5.2	5.5	5.7	6.0	6.3	6.6	6.8
		w/ brake	4.8	5.0	5.3	5.6	5.9	6.1	6.4	6.7	7.0
	RCP6S	w/o brake	4.8	5.0	5.3	5.6	5.9	6.1	6.4	6.7	7.0
		w/ brake	4.9	5.1	5.4	5.7	6.0	6.2	6.5	6.8	7.1

Applicable Controllers

The RCP6 series actuators can be operated by the controllers indicated below. Please select the type depending on your intended use. * Please refer to P.147 for more information about the built-in controller of RCP6S series.

Name	External view	Max. number of controlled axes	Input power	Control method				Maximum number of positioning points	Reference page
				Positioner	Pulse train	Program	Network *Option		
PCON-CB/CGB		1	DC24V	●	●	-		512 (768 for network spec.)	Please see P.132
MCON-C/CG		4		This model is network-compatible only.					
MSEL-PC/PG		4	Single-phase 100~230VAC	-	-	●	Note: The type of compatible networks will vary depending on the controller. Please refer to reference page for more information.	30000	Please see the MSEL-PC/PG catalog or manual.

*Please select "high-output specification" as an option for the MCON. With the MCON, operation is possible only when the high-output specification is selected.

RCP6(S)-RRA8R

Battery-less Absolute
Motor Unit Coupled
Side-mounted Motor
Body Width 85* mm
24v Pulse Motor

Model Specification Items	Series	Type	Encoder Type	Motor Type	Lead	Stroke	Applicable Controller/I/O Type	Cable Length	Options
	RRA8R	WA	60P						
	RCP6: Separate Controller RCP6S: Built-in Controller	WA: Battery-less Absolute	60P: Pulse Motor 60□ Size	20: 20mm 10: 10mm 5: 5mm	50: 50mm 70: 700mm (50mm increments)	[RCP6] P4: PCON- CFB/CGFB [RCP6S] SE: SIO Type	N : None P : 1m S : 3m M : 5m X□ : Specified Length R□ : Robot Cable	Please refer to the options table below. *Please make sure to specify either ML or MR when ordering the side-mounted motor type.	

* RCP6 does not include a controller. RCP6S includes a built-in controller.

* Body width does not include the width of the side-mounted motor.

Radial Load OK

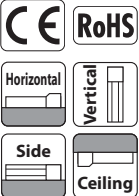

*Depending on the model, there may be some limitations to using the vertical, side, and ceiling mount positions. Please contact IAI for more information regarding mounting positions.

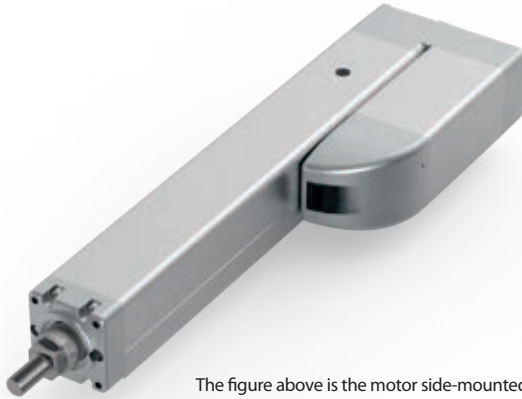

The figure above is the motor side-mounted to the left (ML).



- The maximum acceleration/deceleration is 0.1G for lead 5 and 0.2G for lead 10/20.
- The actuator specification displays the payload's maximum value, but it will vary depending on the acceleration and speed. Please refer to the "Selection Guidelines" (RCP6 Tables of Payload by Speed/Acceleration) on P.115 for more details.
- The radial cylinder is equipped with a built-in guide. Please refer to the graphs shown in P.127 and after for the allowable load mass.
- When performing push-motion operation, please confirm the push force of each model by checking the "Correlation diagram of push force and current limit" on P.113.
- For RCP6S (built-in controller type), please limit the duty cycle to 70% or less.
- The service life of an actuator varies depending on the payload when using vertically. Please refer to P. 114 for more information.

Correlation Diagrams of Speed and Payload

PCON connected.

RCP6(S)-RRA8R Horizontal mount

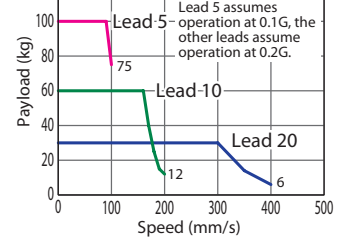

RCP6(S)-RRA8R Vertical mount

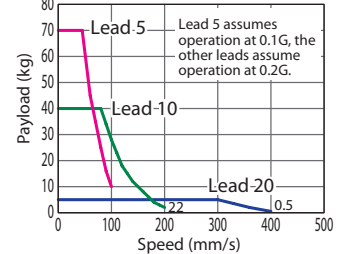

Actuator Specifications

Lead and Payload

(**) The payload assumes that there is an external guide.

Model Number	Lead (mm)	Max. Payload		Stroke (mm)
		Horizontal (kg) (**)	Vertical (kg)	
RCP6(S)-RRA8R-WA-60P-20-①-②-③-④	20	30	5	50~700 (The increment of stroke is 50mm)
RCP6(S)-RRA8R-WA-60P-10-①-②-③-④	10	60	40	
RCP6(S)-RRA8R-WA-60P-5-①-②-③-④	5	100	70	

Legend: ① Stroke ② Applicable controller/I/O type ③ Cable length ④ Options

Stroke and Max. Speed

(Unit: mm/s)

Lead (mm)	50 (mm)	100~450 (mm)	500 (mm)	550 (mm)	600 (mm)	650 (mm)	700 (mm)
20	280	400	360	320	280	240	220
10		200	180	160	140	120	110
5		100	90	80	70	60	55

Cable Length

Cable Type	Cable Code
Standard	P (1m)
	S (3m)
	M (5m)
Specified Length	X06 (6m) ~ X10 (10m)
	X11 (11m) ~ X15 (15m)
	X16 (16m) ~ X20 (20m)
	R01 (1m) ~ R03 (3m)
Robot Cable	R04 (4m) ~ R05 (5m)
	R06 (6m) ~ R10 (10m)
	R11 (11m) ~ R15 (15m)
	R16 (16m) ~ R20 (20m)
	R16 (16m) ~ R20 (20m)

* Refer to P.144 for more information regarding the maintenance cables.

Options

Name	Option Code	Reference Page
Brake	B	See P.105
Cable exit direction (Outside)	CJO	See P.105
Flange	FL	See P.106
Tip adapter (Internal thread)	NFA	See P.109
Motor side-mounted to the left	ML	See P.109
Motor side-mounted to the right	MR	See P.109
Knuckle joint (*)	NJ	See P.110
Non-motor end specification	NM	See P.110
Clevis bracket (*)	QR	See P.111

Actuator Specifications

Item	Description
Drive system	Ball screw ø16mm, rolled C10
Positioning repeatability	±0.01mm
Lost motion	0.1mm or less
Rod	ø40mm Aluminum
Rod non-rotation precision (*)	0 deg.
Allowable load and torque on rod tip	See P. 127
Rod tip offset/overhang distance	dx/dz: 150mm or less
Ambient operating temp. & humidity	0~40°C, 85% RH or less (Non-condensing)

(*) Rod's angular displacement in rotational direction with no load applied to the rod.

Offset distance at end of rod (dx: 150mm or less)

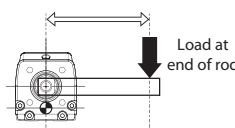

Overhang distance at end of rod (dz: 150mm or less)

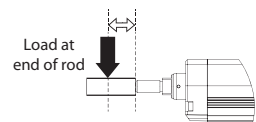

(*) The clevis (QR) and knuckle joint (NJ) are sold as a set. The assembly is to be performed by the customer.

Dimensions

CAD drawings can be downloaded from our website.
www.robocylinder.de



- *1 When the rod is returning to its home position, please be careful of interference from surrounding objects, as it will travel until it reaches the M.E. M.E: Mechanical end S.E: Stroke end
- *2 The direction of width across flats varies depending on the product.
- *3 When fixing the actuator using a front bracket or flange, please make sure that there is no external force applied to the main body.

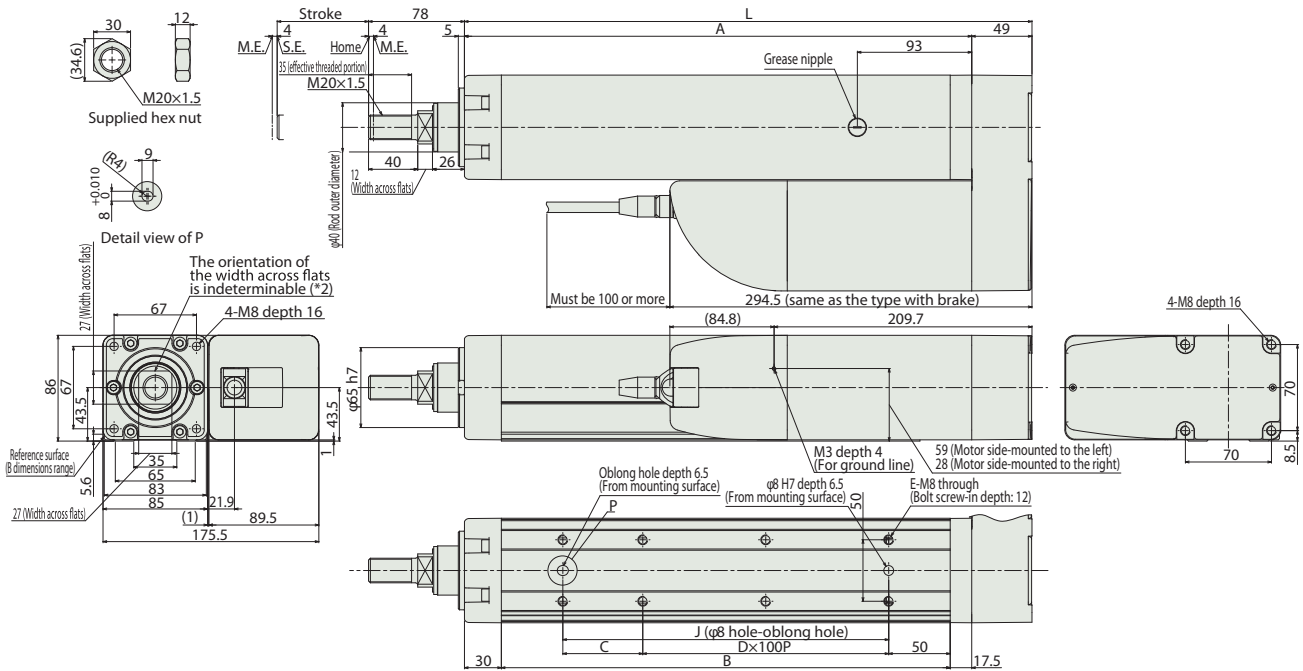

RCP6S-RRR4R

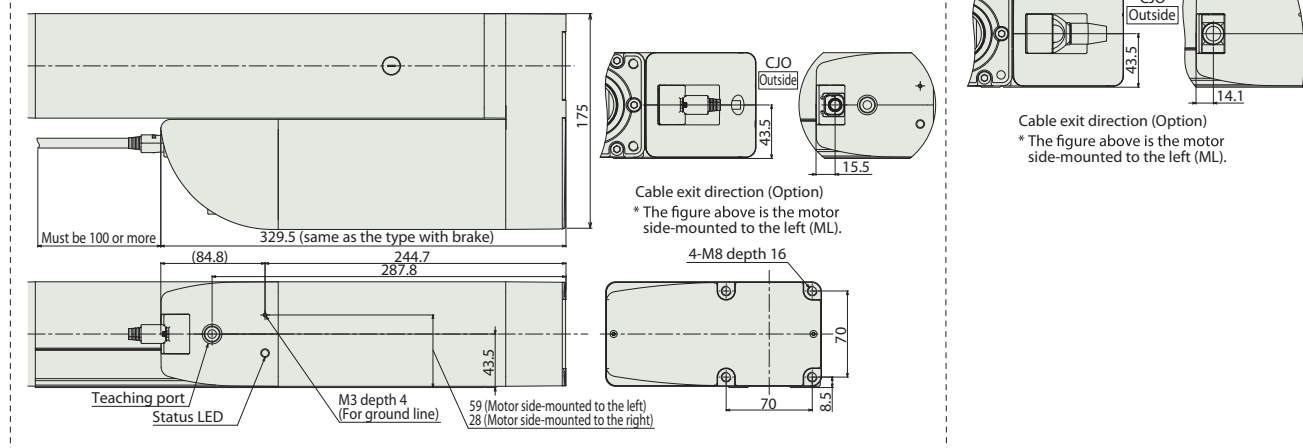

Rod Deflection of RCP6(S)-RRR4R (Reference Values)

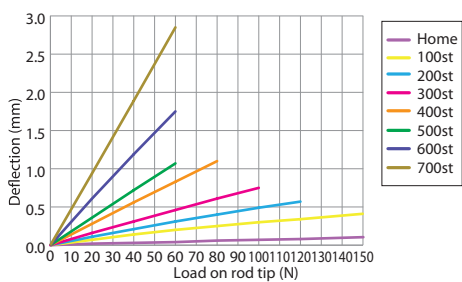

Dimensions and Mass by Stroke

Stroke	50	100	150	200	250	300	350	400	450	500	550	600	650	700		
L	311.5	361.5	411.5	461.5	511.5	561.5	611.5	661.5	711.5	761.5	811.5	861.5	911.5	961.5		
A	262.5	312.5	362.5	412.5	462.5	512.5	562.5	612.5	662.5	712.5	762.5	812.5	862.5	912.5		
B	215	265	315	365	415	465	515	565	615	665	715	765	815	865		
C	115	65	115	65	115	65	115	65	115	65	115	65	115	65		
D	0	1	1	2	2	3	3	4	4	5	5	6	6	7		
E	4	6	6	8	8	10	10	12	12	14	14	16	16	18		
J	115	165	215	265	315	365	415	465	515	565	615	665	715	765		
Allowable static load on rod tip (N)	222	186	159	139	124	111	101	92.1	84.7	78.4	72.8	68	63.7	59.8		
Allowable dynamic load on rod tip (kg)	9.5	7.8	6.6	5.7	5.0	4.5	4.0	3.6	3.3	3.0	2.8	2.6	2.4	2.2		
Allowable static torque on rod tip (N·m)	22.3	18.7	16.1	14.1	12.6	11.3	10.3	9.4	8.7	8.1	7.6	7.1	6.7	6.3		
Allowable dynamic torque on rod tip (N·m)	7.2	6.2	5.4	4.8	4.3	3.9	3.5	3.2	3.0	2.7	2.5	2.4	2.2	2.0		
Mass (kg)	RCP6	w/o brake	7.9	8.3	8.8	9.3	9.8	10.2	10.7	11.2	11.7	12.1	12.6	13.1	13.6	14.0
		w/ brake	8.1	8.6	9.1	9.6	10.0	10.5	11.0	11.5	11.9	12.4	12.9	13.4	13.8	14.3
	RCP6S	w/o brake	8.1	8.5	9.0	9.5	10.0	10.4	10.9	11.4	11.9	12.3	12.8	13.3	13.8	14.2
		w/ brake	8.3	8.8	9.3	9.8	10.2	10.7	11.2	11.7	12.1	12.6	13.1	13.6	14.0	14.5

Applicable Controllers

The RCP6 series actuators can be operated by the controllers indicated below. Please select the type depending on your intended use. * Please refer to P.147 for more information about the built-in controller of RCP6S series.

Name	External view	Max. number of controlled axes	Input power	Control method			Maximum number of positioning points	Reference page
				Positioner	Pulse train	Program		
PCON-CFB/CGFB		1	DC24V	*Option	*Option	-	512 (768 for network spec.)	Please see P.132

RCP6(S)-WRA10C

Battery-less Absolute
Motor Unit Coupled
Straight Motor
Body Width 100 mm
24v Pulse Motor

Model Specification Items	Series	Type	Encoder Type	Motor Type	Lead	Stroke	Applicable Controller/I/O Type	Cable Length	Options
	RCP6: Separate Controller RCP6S: Built-in Controller	WRA10C	WA	35P	16: 16mm 10: 10mm 5: 5mm 2.5: 2.5mm	50: 50mm ? 500: 500mm (50mm increments)	[RCP6] P3: PCON MCON MSEL [RCP6S] SE: SIO Type	N : None P : 1m S : 3m M : 5m X□ : Specified Length R□ : Robot Cable	Please refer to the options table below.

* RCP6 does not include a controller. RCP6S includes a built-in controller.

Radial Load OK

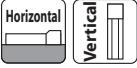

*Depending on the model, there may be some limitations to using the vertical, side, and ceiling mount positions. Please contact IAI for more information regarding mounting positions.



- (1) The maximum acceleration/deceleration is 1G for horizontal, and 0.5G for vertical use.
- (2) The actuator specification displays the payload's maximum value, but it will vary depending on the acceleration and speed. Please refer to the "Selection Guidelines" (RCP6 Tables of Payload by Speed/Acceleration) on P.115 for more details.
- (3) The radial cylinder is equipped with a built-in guide. Please refer to the graphs shown in P.127 and after for the allowable load mass.
- (4) When performing push-motion operation, please confirm the push force of each model by checking the "Correlation diagram of push force and current limit" on P.113.

Correlation Diagrams of Speed and Payload

High-output enabled (*) with PCON/MCON/MSEL connected. RCP6(S)-WRA10C Horizontal mount

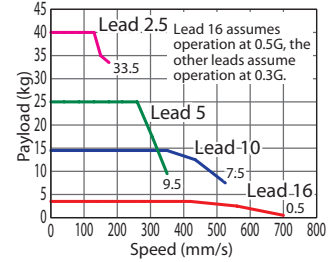

RCP6(S)-WRA10C Vertical mount

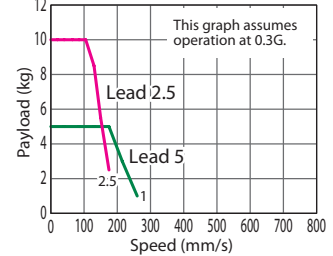

(*) For high output setting to OFF refer to the RCP6 manual.

Actuator Specifications (*)

(*) For values of disabled high output controller setting refer to the RCP6 manual.

Lead and Payload

(**) The payload assumes that there is an external guide.

Model Number	Lead (mm)	Connected Controller	Max. Payload		Stroke (mm)
			Horizontal (kg) (**)	Vertical (kg)	
RCP6(S)-WRA10C-WA-35P-16-①-②-③-④	16	High-output Enabled	4	-	50~500 (The increment of stroke is 50mm)
RCP6(S)-WRA10C-WA-35P-10-①-②-③-④	10	High-output Enabled	14.5	-	
RCP6(S)-WRA10C-WA-35P-5-①-②-③-④	5	High-output Enabled	28	5	
RCP6(S)-WRA10C-WA-35P-2.5-①-②-③-④	2.5	High-output Enabled	40	10	

Stroke and Max. Speed

(Unit: mm/s)

Lead (mm)	Connected Controller	50~400 (Every 50mm)		
		450 (mm)	500 (mm)	
16	High-output Enabled	700		
10	High-output Enabled	525	490	
5	High-output Enabled	350 <260>	290 <260>	240
2.5	High-output Enabled	175	145	120

Legend: ① Stroke ② Applicable controller/I/O type ③ Cable length ④ Options

Values in brackets < > are for vertical use.

Cable Length

Cable Type	Cable Code
Standard	P (1m)
	S (3m)
	M (5m)
Specified Length	X06 (6m) ~ X10 (10m)
	X11 (11m) ~ X15 (15m)
	X16 (16m) ~ X20 (20m)
	R01 (1m) ~ R03 (3m)
Robot Cable	R04 (4m) ~ R05 (5m)
	R06 (6m) ~ R10 (10m)
	R11 (11m) ~ R15 (15m)
	R16 (16m) ~ R20 (20m)

* Refer to P.144 for more information regarding the maintenance cables.

Options

Name	Option Code	Reference Page
Brake	B	See P.105
Cable exit direction (Top)	CJT	See P.105
Cable exit direction (Right)	CJR	See P.105
Cable exit direction (Left) (*)	CJL	See P.105
Cable exit direction (Bottom)	CJB	See P.105
Flange	FL	See P.106
Non-motor end specification	NM	See P.110
T-slot nut bar (Left)	NTBL	See P.110
T-slot nut bar (Right)	NTBR	See P.110

(*) This option is not available for the straight type RCP6S-WRA10C with built-in controller.

Actuator Specifications

Item	Description
Drive system	Ball screw ø8mm, rolled C10
Positioning repeatability	±0.01mm
Lost motion	0.1mm or less
Rod	ø25mm Stainless steel
Rod non-rotation precision (*)	0 deg.
Allowable load and torque on rod tip	See P. 129
Rod tip offset/overhang distance	dx/dz: 100mm or less
Ambient operating temp. & humidity	0~40°C, 85% RH or less (Non-condensing)

(*) Rod's angular displacement in rotational direction with no load applied to the rod.

Offset distance at end of rod (dx: 100mm or less)

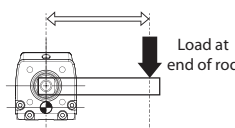

Overhang distance at end of rod (dz: 100mm or less)

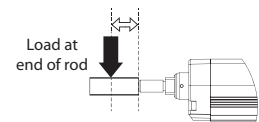

Dimensions

CAD drawings can be downloaded from our website.
www.robocylinder.de



*1 When the rod is returning to its home position, please be careful of interference from surrounding objects, as it will travel until it reaches the M.E. M.E: Mechanical end S.E: Stroke end
*2 When the overhang is large or severe adjustment of the angle is required, please attach the fittings without using the reamed hole.

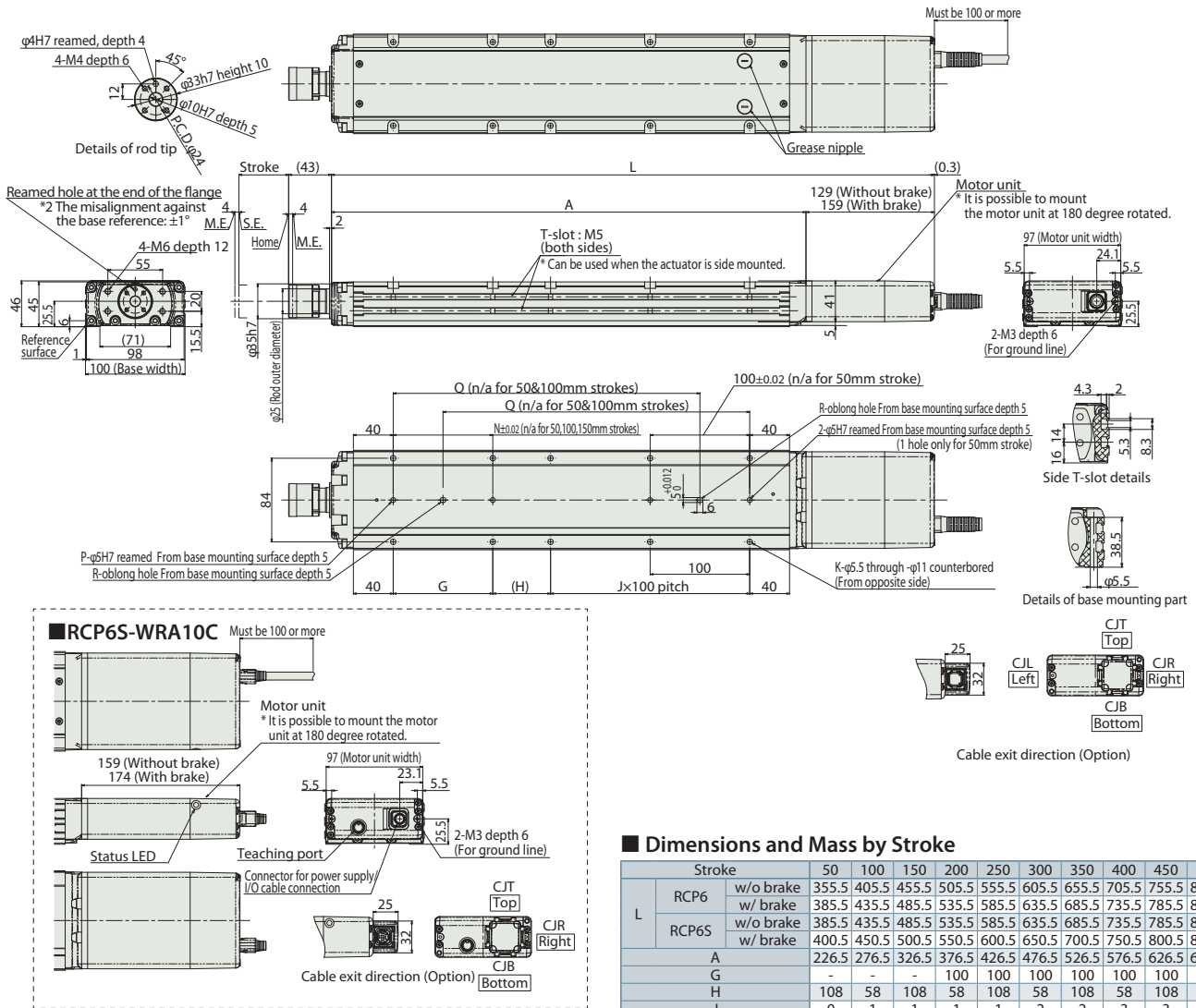

■ Rod Deflection of RCP6(S)-WRA10C (Reference Values)

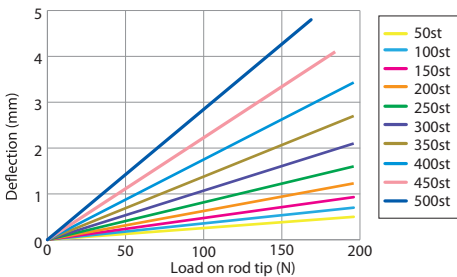

■ Dimensions and Mass by Stroke

L	Stroke	Stroke									
		50	100	150	200	250	300	350	400	450	500
RCP6	w/o brake	355.5	405.5	455.5	505.5	555.5	605.5	655.5	705.5	755.5	805.5
	w/ brake	385.5	435.5	485.5	535.5	585.5	635.5	685.5	735.5	785.5	835.5
RCP6S	w/o brake	385.5	435.5	485.5	535.5	585.5	635.5	685.5	735.5	785.5	835.5
	w/ brake	400.5	450.5	500.5	550.5	600.5	650.5	700.5	750.5	800.5	850.5
A		226.5	276.5	326.5	376.5	426.5	476.5	526.5	576.5	626.5	676.5
G		-	-	-	100	100	100	100	100	100	100
H		108	58	108	58	108	58	108	58	108	58
J		0	1	1	1	1	2	2	3	3	4
K		4	6	6	8	8	10	10	12	12	14
N		-	-	-	100	100	100	100	100	100	100
P		1	1	1	2	2	2	2	2	2	2
Q		-	-	158	208	258	308	358	408	458	508
R		0	0	1	1	1	1	1	1	1	1
Allowable static load on rod tip (N)		196	196	196	196	196	196	196	196	184	169
Allowable static torque on rod tip (N·m)		10	10	10	10	10	10	10	10	10	10
3,000km	Allowable dynamic load on rod tip (N)	98	98	98	95	85	76	68	62	57	52
	Load offset 0mm	50	50	50	50	50	50	50	50	50	49
	Load offset 100mm	50	50	50	50	50	50	50	50	50	49
	Allowable dynamic torque on rod tip (N·m)	5.0	5.0	5.0	5.0	5.0	5.0	5.0	5.0	5.0	4.9
5,000km	Allowable dynamic load on rod tip (N)	98	98	91	80	71	63	57	52	47	43
	Load offset 0mm	50	50	50	50	50	50	50	48	44	40
	Load offset 100mm	50	50	50	50	50	50	50	4.8	4.4	4.0
	Allowable dynamic torque on rod tip (N·m)	5.0	5.0	5.0	5.0	5.0	5.0	5.0	4.8	4.4	4.0
Mass (kg)	w/o brake	3.3	3.8	4.2	4.7	5.1	5.6	6.0	6.5	6.9	7.4
	w/ brake	3.5	4.0	4.4	4.9	5.3	5.8	6.2	6.7	7.1	7.6
RCP6S	w/o brake	3.4	3.9	4.3	4.8	5.2	5.7	6.1	6.6	7.0	7.5
	w/ brake	3.6	4.1	4.5	4.9	5.4	5.8	6.3	6.7	7.2	7.6

Applicable Controllers

The RCP6 series actuators can be operated by the controllers indicated below. Please select the type depending on your intended use. * Please refer to P.147 for more information about the built-in controller of RCP6S series.

Name	External view	Max. number of controlled axes	Input power	Control method				Maximum number of positioning points	Reference page
				Positioner	Pulse train	Program	Network *Option		
PCON-CB/CGB		1	DC24V	● *Option	● *Option	-	 	512 (768 for network spec.)	Please see P.132
MCON-C/CG		4		This model is network-compatible only.				 	256
MSEL-PC/PG		4	Single-phase 100~230VAC	-	-	●	Note: The type of compatible networks will vary depending on the controller. Please refer to reference page for more information.	30000	Please see the MSEL-PC/PG catalog or manual.

*Please select "high-output specification" as an option for the MCON. With the MCON, operation is possible only when the high-output specification is selected.

RCP6(S)-WRA12C

Battery-less Absolute
Motor Unit Coupled
Straight Motor
Body Width 120 mm
24v Pulse Motor

Model Specification Items	Series	Type	Encoder Type	Motor Type	Lead	Stroke	Applicable Controller/I/O Type	Cable Length	Options
	□	WRA12C	WA	42P	□	□	□	□	□
	RCP6: Separate Controller RCP6S: Built-in Controller		WA: Battery-less Absolute	42P: Pulse Motor 42□ Size	20: 20mm 12: 12mm 6: 6mm 3: 3mm	50: 50mm 1 500: 500mm (50mm increments)	[RCP6] P3: PCON MCON MSEL [RCP6S] SE: SIO Type	N : None P : 1m S : 3m M : 5m X□ : Specified Length R□ : Robot Cable	Please refer to the options table below.

* RCP6 does not include a controller. RCP6S includes a built-in controller.

Radial Load OK

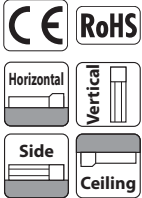

*Depending on the model, there may be some limitations to using the vertical, side, and ceiling mount positions. Please contact IAI for more information regarding mounting positions.

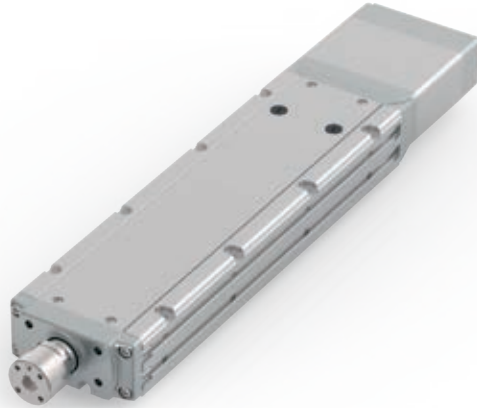

- POINT Selection Notes**
- (1) The maximum acceleration/deceleration is 1G for horizontal, and 0.5G for vertical use.
 - (2) The actuator specification displays the payload's maximum value, but it will vary depending on the acceleration and speed. Please refer to the "Selection Guidelines" (RCP6 Tables of Payload by Speed/Acceleration) on P.115 for more details.
 - (3) The radial cylinder is equipped with a built-in guide. Please refer to the graphs shown in P.127 and after for the allowable load mass.
 - (4) When performing push-motion operation, please confirm the push force of each model by checking the "Correlation diagram of push force and current limit" on P.113.
 - (5) Depending on the ambient operational temperature, duty control is necessary for the RCP6S (built-in controller type) with lead 3/6. Please refer to P.130 for more information.

Correlation Diagrams of Speed and Payload

High-output enabled (*) with PCON/MCON/MSEL connected.
RCP6(S)-WRA12C Horizontal mount

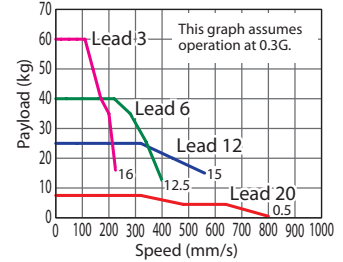

RCP6(S)-WRA12C Vertical mount

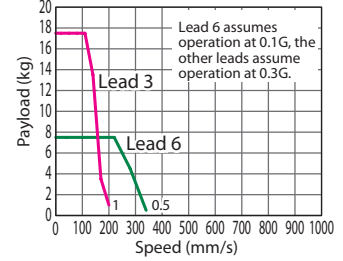

(*) For high output setting to OFF refer to the RCP6 manual.

Actuator Specifications (*)

(*) For values of disabled high output controller setting refer to the RCP6 manual.

Lead and Payload

(**) The payload assumes that there is an external guide.

Model Number	Lead (mm)	Connected Controller	Max. Payload		Stroke (mm)
			Horizontal (kg) (**)	Vertical (kg)	
RCP6(S)-WRA12C-WA-42P-20-①-②-③-④	20	High-output Enabled	7.5	-	50~500 (The increment of stroke is 50mm)
RCP6(S)-WRA12C-WA-42P-12-①-②-③-④	12	High-output Enabled	30	-	
RCP6(S)-WRA12C-WA-42P-6-①-②-③-④	6	High-output Enabled	55	7.5	
RCP6(S)-WRA12C-WA-42P-3-①-②-③-④	3	High-output Enabled	70	17.5	

Stroke and Max. Speed

(Unit: mm/s)

Lead (mm)	Connected Controller	50~400 (Every 50mm)	450 (mm)	500 (mm)
20	High-output Enabled		800	
12	High-output Enabled		560	
6	High-output Enabled	400 <340>		375 <340>
3	High-output Enabled	225 <200>	220 <200>	185

Legend: ① Stroke ② Applicable controller/I/O type ③ Cable length ④ Options

Values in brackets < > are for vertical use.

Cable Length

Cable Type	Cable Code
Standard	P (1m)
	S (3m)
	M (5m)
Specified Length	X06 (6m) ~ X10 (10m)
	X11 (11m) ~ X15 (15m)
	X16 (16m) ~ X20 (20m)
	R01 (1m) ~ R03 (3m)
Robot Cable	R04 (4m) ~ R05 (5m)
	R06 (6m) ~ R10 (10m)
	R11 (11m) ~ R15 (15m)
	R16 (16m) ~ R20 (20m)

* Refer to P.144 for more information regarding the maintenance cables.

Options

Name	Option Code	Reference Page
Brake	B	See P.105
Cable exit direction (Top)	CJT	See P.105
Cable exit direction (Right)	CJR	See P.105
Cable exit direction (Left)	CJL	See P.105
Cable exit direction (Bottom)	CJB	See P.105
Flange	FL	See P.106
Non-motor end specification	NM	See P.110
T-slot nut bar (Left)	NTBL	See P.110
T-slot nut bar (Right)	NTBR	See P.110

Actuator Specifications

Item	Description
Drive system	Ball screw ø10mm, rolled C10
Positioning repeatability	±0.01mm
Lost motion	0.1mm or less
Rod	ø30mm Stainless steel
Rod non-rotation precision (*)	0 deg.
Allowable load and torque on rod tip	See P. 129
Rod tip offset/overhang distance	dx/dz: 100mm or less
Ambient operating temp. & humidity	0~40°C, 85% RH or less (Non-condensing)

(*) Rod's angular displacement in rotational direction with no load applied to the rod.

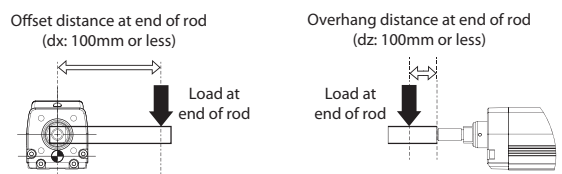

Dimensions

CAD drawings can be downloaded from our website.
www.robocylinder.de



*1 When the rod is returning to its home position, please be careful of interference from surrounding objects, as it will travel until it reaches the M.E. M.E: Mechanical end S.E: Stroke end
*2 When the overhang is large or severe adjustment of the angle is required, please attach the fittings without using the reamed hole.

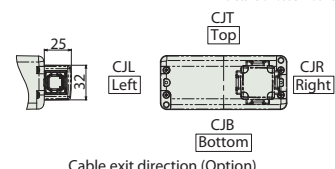
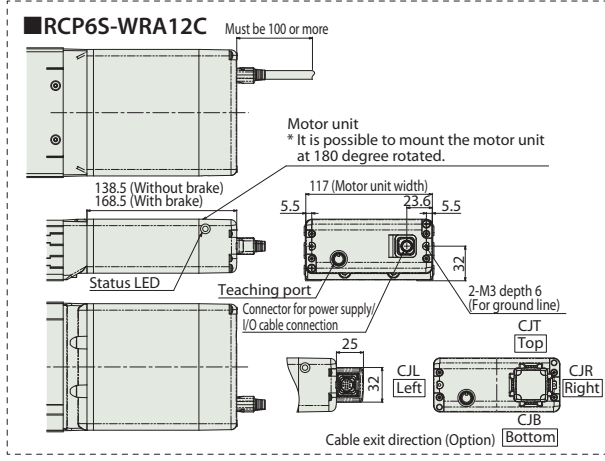
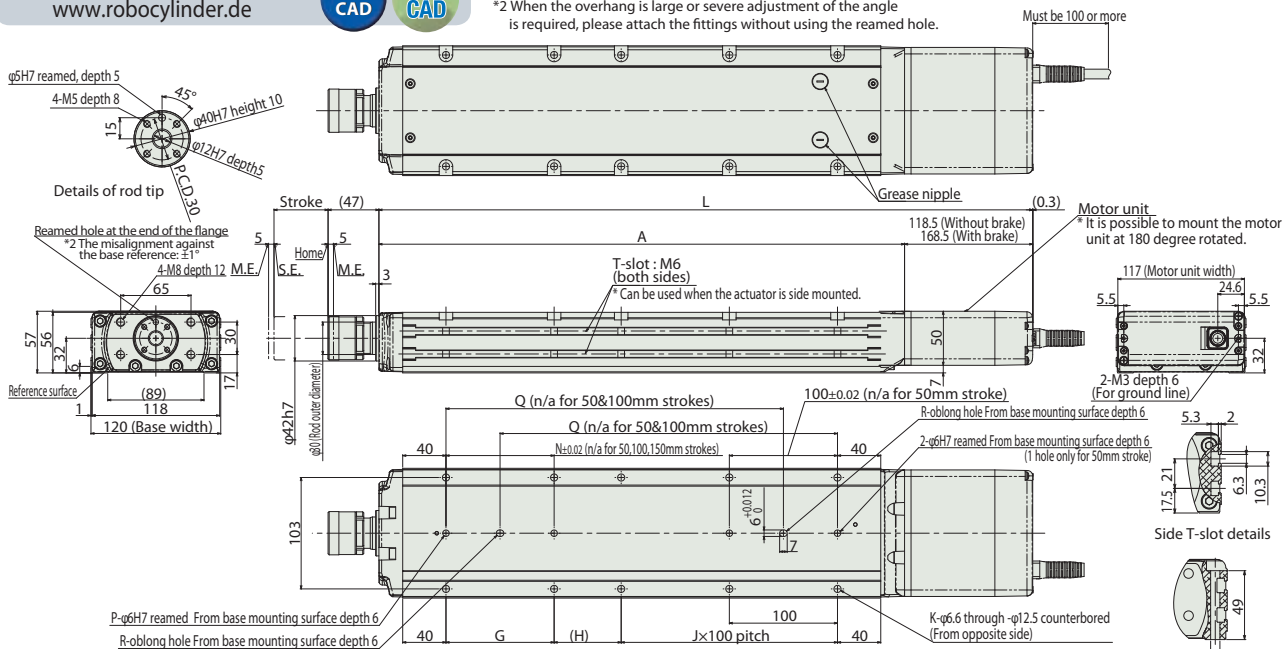

Dimensions and Mass by Stroke

L	Stroke	Stroke									
		50	100	150	200	250	300	350	400	450	500
RCP6	w/o brake	354.5	404.5	454.5	504.5	554.5	604.5	654.5	704.5	754.5	804.5
	w/ brake	404.5	454.5	504.5	554.5	604.5	654.5	704.5	754.5	804.5	854.5
RCP6S	w/o brake	374.5	424.5	474.5	524.5	574.5	624.5	674.5	724.5	774.5	824.5
	w/ brake	404.5	454.5	504.5	554.5	604.5	654.5	704.5	754.5	804.5	854.5
A		236	286	336	386	436	486	536	586	636	686
G		-	-	-	100	100	100	100	100	100	100
H		112	62	112	62	112	62	112	62	112	62
J		0	1	1	1	1	2	2	3	3	4
K		4	6	6	8	8	10	10	12	12	14
N		-	-	-	100	100	100	100	100	100	100
P		1	1	1	2	2	2	2	2	2	2
Q		-	-	162	212	262	312	362	412	462	512
R		0	0	1	1	1	1	1	1	1	1
Allowable static load on rod tip (N)		294	294	294	294	294	269	241	218	198	181
Allowable static torque on rod tip (N-m)		20	20	20	20	20	20	20	20	20	20
3,000mm	Allowable dynamic load on rod tip (N)	147	147	137	121	107	96	87	79	72	65
	Load offset 0mm	100	100	100	100	99	90	82	75	68	63
	Load offset 100mm	100	100	100	100	99	90	82	75	68	63
	Allowable dynamic torque on rod tip (N-m)	10.0	10.0	10.0	10.0	9.9	9.0	8.2	7.5	6.8	6.3
5,000mm	Allowable dynamic load on rod tip (N)	147	133	115	101	90	80	72	65	59	54
	Load offset 0mm	100	100	100	92	83	75	68	62	56	51
	Load offset 100mm	100	100	100	92	83	75	68	62	56	51
	Allowable dynamic torque on rod tip (N-m)	10.0	10.0	10.0	9.2	8.3	7.5	6.8	6.2	5.6	5.1
Mass (kg)	w/o brake	4.7	5.3	6.0	6.6	7.3	7.9	8.5	9.2	9.8	10.5
	w/ brake	5.0	5.6	6.3	6.9	7.6	8.2	8.8	9.5	10.1	10.8
RCP6S	w/o brake	4.8	5.4	6.1	6.7	7.3	8.0	8.6	9.3	9.9	10.5
	w/ brake	5.0	5.7	6.3	6.9	7.6	8.2	8.9	9.5	10.1	10.8

Rod Deflection of RCP6(S)-WRA12C (Reference Values)

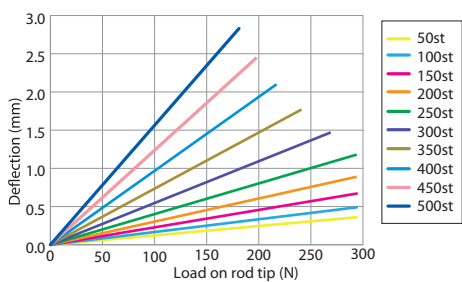

RCP6-WRA12C-(BK)

Applicable Controllers

The RCP6 series actuators can be operated by the controllers indicated below. Please select the type depending on your intended use. * Please refer to P.147 for more information about the built-in controller of RCP6S series.

Name	External view	Max. number of controlled axes	Input power	Control method				Maximum number of positioning points	Reference page
				Positioner	Pulse train	Program	Network *Option		
PCON-CB/CGB		1	DC24V	● *Option	● *Option	-		512 (768 for network spec.)	Please see P.132
MCON-C/CG		4		This model is network-compatible only.					256
MSEL-PC/PG		4	Single-phase 100~230VAC	-	-	●	Note: The type of compatible networks will vary depending on the controller. Please refer to reference page for more information.	30000	Please see the MSEL-PC/PG catalog or manual.

*Please select "high-output specification" as an option for the MCON. With the MCON, operation is possible only when the high-output specification is selected.

RCP6(S)-WRA14C

Battery-less Absolute
Motor Unit Coupled
Straight Motor
Body Width 140 mm
24v Pulse Motor

Model Specification Items	Series	Type	Encoder Type	Motor Type	Lead	Stroke	Applicable Controller/I/O Type	Cable Length	Options
	—	WRA14C	WA	56P	—	—	—	—	—
	RCP6: Separate Controller RCP6S: Built-in Controller		WA: Battery-less Absolute	56P: Pulse Motor 56□ Size	24: 24mm 16: 16mm 8: 8mm 4: 4mm	50: 50mm 600: 600mm (50mm increments)	[RCP6] P3: PCON MCON MSEL [RCP6S] SE: SIO Type	N : None P : 1m S : 3m M : 5m X□ : Specified Length R□ : Robot Cable	Please refer to the options table below.

* RCP6 does not include a controller. RCP6S includes a built-in controller.

Radial Load OK

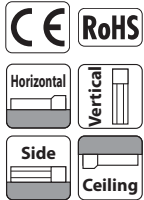

*Depending on the model, there may be some limitations to using the vertical, side, and ceiling mount positions. Please contact IAI for more information regarding mounting positions.

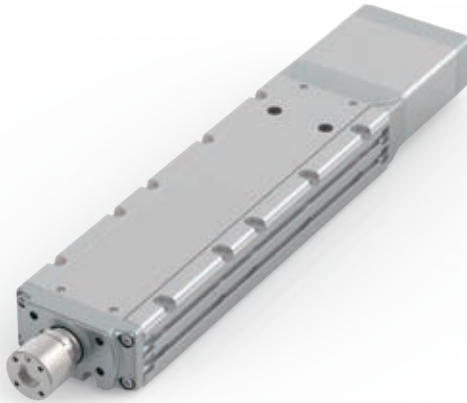

- (1) The maximum acceleration/deceleration is 1G for horizontal, and 0.5G for vertical use.
- (2) The actuator specification displays the payload's maximum value, but it will vary depending on the acceleration and speed. Please refer to the "Selection Guidelines" (RCP6 Tables of Payload by Speed/Acceleration) on P.115 for more details.
- (3) The radial cylinder is equipped with a built-in guide. Please refer to the graphs shown in P.127 and after for the allowable load mass.
- (4) When performing push-motion operation, please confirm the push force of each model by checking the "Correlation diagram of push force and current limit" on P.113.
- (5) Depending on the ambient operational temperature, duty control is necessary for the RCP6S (built-in controller type) with lead 4/8/16. Please refer to P.130 for more information.

Correlation Diagrams of Speed and Payload

High-output enabled (*) with PCON/MCON/MSEL connected.
RCP6(S)-WRA14C Horizontal mount

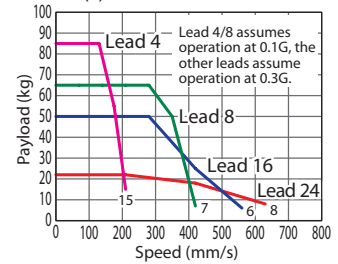

RCP6(S)-WRA14C Vertical mount

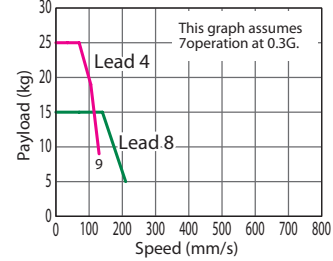

(*) For high output setting to OFF refer to the RCP6 manual.

Actuator Specifications (*)

(*) For values of disabled high output controller setting refer to the RCP6 manual.

Lead and Payload

(**) The payload assumes that there is an external guide.

Model Number	Lead (mm)	Connected Controller	Max. Payload		Stroke (mm)
			Horizontal (kg/□)	Vertical (kg)	
RCP6(S)-WRA14C-WA-56P-24-①-②-③-④	24	High-output Enabled	25	-	50~600 (The increment of stroke is 50mm)
RCP6(S)-WRA14C-WA-56P-16-①-②-③-④	16	High-output Enabled	50	-	
RCP6(S)-WRA14C-WA-56P-8-①-②-③-④	8	High-output Enabled	65	15	
RCP6(S)-WRA14C-WA-56P-4-①-②-③-④	4	High-output Enabled	85	25	

Stroke and Max. Speed

(Unit: mm/s)

Lead (mm)	Connected Controller	50~550 (Every 50mm)		600 (mm)
		50~550 (Every 50mm)	600 (mm)	
24	High-output Enabled	630		
16	High-output Enabled	560		
8	High-output Enabled	420 <210>	395 <210>	
4	High-output Enabled	210 <130>	195 <130>	

Legend: ① Stroke ② Applicable controller/I/O type ③ Cable length ④ Options

Values in brackets < > are for vertical use.

Cable Length

Cable Type	Cable Code
Standard	P (1m)
	S (3m)
	M (5m)
Specified Length	X06 (6m) ~ X10 (10m)
	X11 (11m) ~ X15 (15m)
	X16 (16m) ~ X20 (20m)
	R01 (1m) ~ R03 (3m)
Robot Cable	R04 (4m) ~ R05 (5m)
	R06 (6m) ~ R10 (10m)
	R11 (11m) ~ R15 (15m)
	R16 (16m) ~ R20 (20m)
	R16 (16m) ~ R20 (20m)

* Refer to P.144 for more information regarding the maintenance cables.

Options

Name	Option Code	Reference Page
Brake	B	See P.105
Cable exit direction (Top)	CJT	See P.105
Cable exit direction (Right)	CJR	See P.105
Cable exit direction (Left)	CJL	See P.105
Cable exit direction (Bottom)	CJB	See P.105
Flange	FL	See P.106
Non-motor end specification	NM	See P.110
T-slot nut bar (Left)	NTBL	See P.110
T-slot nut bar (Right)	NTBR	See P.110

Actuator Specifications

Item	Description
Drive system	Ball screw ø12mm, rolled C10
Positioning repeatability	±0.01mm
Lost motion	0.1mm or less
Rod	ø40mm Stainless steel
Rod non-rotation precision (*)	0 deg.
Allowable load and torque on rod tip	See P. 129
Rod tip offset/overhang distance	dx: 150mm or less / dz: 100mm or less
Ambient operating temp. & humidity	0~40°C, 85% RH or less (Non-condensing)

(*) Rod's angular displacement in rotational direction with no load applied to the rod.

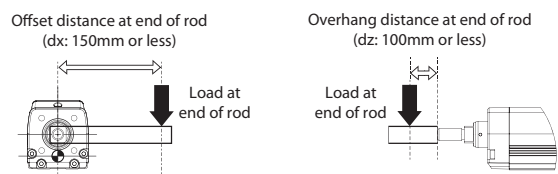

Dimensions

CAD drawings can be downloaded from our website.
www.robo-cylinder.de



*1 When the rod is returning to its home position, please be careful of interference from surrounding objects, as it will travel until it reaches the M.E. M.E: Mechanical end S.E: Stroke end
*2 When the overhang is large or severe adjustment of the angle is required, please attach the fittings without using the reamed hole.

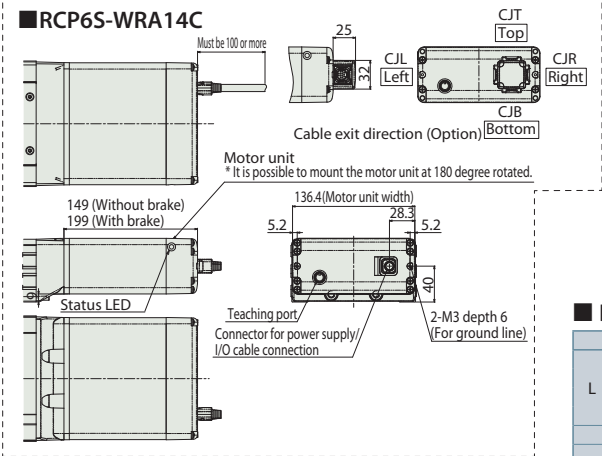
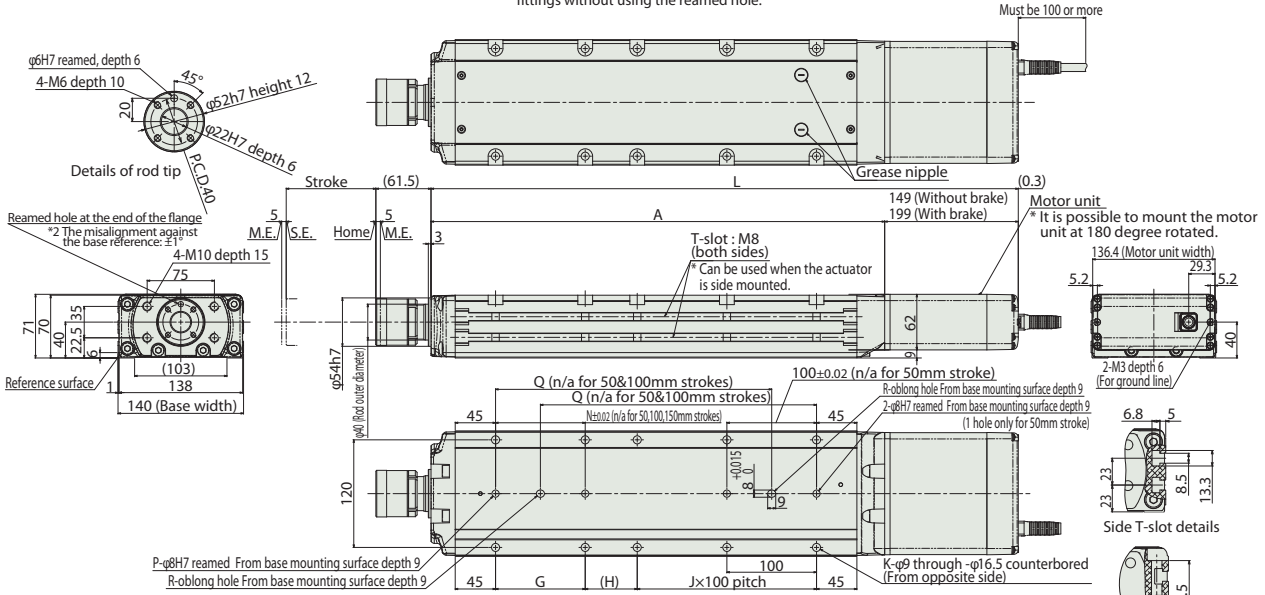

Dimensions and Mass by Stroke

Stroke		50	100	150	200	250	300	350	400	450	500	550	600
L	RCP6 w/o brake	405	455	505	555	605	655	705	755	805	855	905	955
	RCP6S w/o brake	405	455	505	555	605	655	705	755	805	855	905	955
	RCP6 w/ brake	455	505	555	605	655	705	755	805	855	905	955	1,005
	RCP6S w/ brake	455	505	555	605	655	705	755	805	855	905	955	1,005
A		256	306	356	406	456	506	556	606	656	706	756	806
G		-	-	-	100	100	100	100	100	100	100	100	100
H		108	58	108	58	108	58	108	58	108	58	108	58
J		0	1	1	1	1	2	2	3	3	4	4	5
K		4	6	6	8	8	10	10	12	12	14	14	16
N		-	-	-	100	100	100	100	100	100	100	100	100
P		1	1	1	2	2	2	2	2	2	2	2	2
Q		-	-	158	208	258	308	358	408	458	508	558	608
R		0	0	1	1	1	1	1	1	1	1	1	1
3,000Nm	Allowable static load on rod tip (N-m)	30	30	30	30	30	30	30	30	30	30	30	30
	Allowable dynamic load on rod tip (N)	199	170	148	131	117	104	94	85	77	70	64	58
	Load offset 0mm	100	100	100	100	100	95	87	79	72	66	60	55
	Load offset 100mm	15.0	15.0	15.0	15.0	15.0	14.3	13.0	11.8	10.8	9.9	9.0	8.2
5,000Nm	Allowable static load on rod tip (N-m)	167	143	124	109	97	87	78	70	63	57	51	46
	Allowable dynamic load on rod tip (N)	100	100	100	96	87	79	71	65	59	53	48	44
	Load offset 0mm	15.0	15.0	15.0	14.4	13.0	11.8	10.7	9.7	8.8	8.0	7.3	6.6
	Load offset 100mm	8.0	8.9	9.8	10.6	11.5	12.4	13.3	14.2	15.0	15.9	16.8	17.7
Mass (kg)	RCP6 w/o brake	8.5	9.4	10.2	11.1	12.0	12.9	13.8	14.6	15.5	16.4	17.3	18.2
	RCP6S w/o brake	8.0	8.9	9.8	10.7	11.6	12.4	13.3	14.2	15.1	16.0	16.8	17.7
	RCP6 w/ brake	8.5	9.4	10.3	11.2	12.0	12.9	13.8	14.7	15.6	16.4	17.3	18.2
	RCP6S w/ brake	8.5	9.4	10.3	11.2	12.0	12.9	13.8	14.7	15.6	16.4	17.3	18.2

Rod Deflection of RCP6(S)-WRA14C (Reference Values)

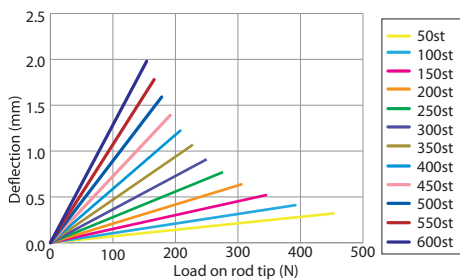

Applicable Controllers

The RCP6 series actuators can be operated by the controllers indicated below. Please select the type depending on your intended use. * Please refer to P.147 for more information about the built-in controller of RCP6S series.

Name	External view	Max. number of controlled axes	Input power	Control method				Maximum number of positioning points	Reference page
				Positioner	Pulse train	Program	Network *Option		
PCON-CB/CGB		1	DC24V	● *Option	● *Option	-		512 (768 for network spec.)	Please see P.132
MCON-C/CG		4		This model is network-compatible only.					
MSEL-PC/PG		4	Single-phase 100~230VAC	-	-	●	Note: The type of compatible networks will vary depending on the controller. Please refer to reference page for more information.	30000	Please see the MSEL-PC/PG catalog or manual.

*Please select "high-output specification" as an option for the MCON. With the MCON, operation is possible only when the high-output specification is selected.

RCP6(S)-WRA16C

Battery-less Absolute
Motor Unit Coupled
Straight Motor
Body Width 160 mm
24v Pulse Motor

Model Specification Items	Series	Type	Encoder Type	Motor Type	Lead	Stroke	Applicable Controller/I/O Type	Cable Length	Options
	□	WRA16C	WA	60P	□	□	□	□	□
	RCP6: Separate Controller RCP6S: Built-in Controller		WA: Battery-less Absolute	60P: Pulse Motor 60□ Size	20: 20mm 10: 10mm 5: 5mm	50: 50mm 1 800: 800mm (50mm increments)	[RCP6] P4: PCON- CFB/CGFB [RCP6S] SE: SIO Type	N : None P : 1m S : 3m M : 5m X□ : Specified Length R□ : Robot Cable	Please refer to the options table below.

* RCP6 does not include a controller. RCP6S includes a built-in controller.

Radial Load OK

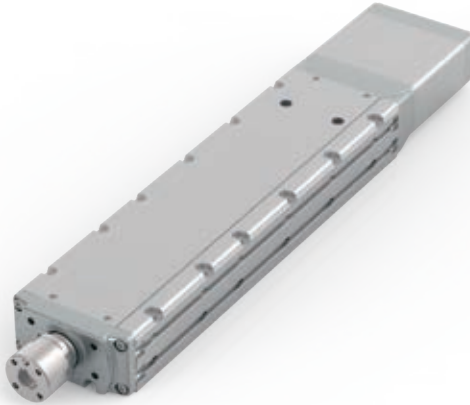
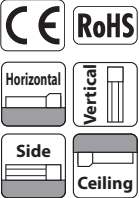

*Depending on the model, there may be some limitations to using the vertical, side, and ceiling mount positions. Please contact IAI for more information regarding mounting positions.



- The maximum acceleration/deceleration is 0.1G for lead 5 and 0.2G for lead 10/20.
- The actuator specification displays the payload's maximum value, but it will vary depending on the acceleration and speed. Please refer to the "Selection Guidelines" (RCP6 Tables of Payload by Speed/Acceleration) on P.115 for more details.
- The radial cylinder is equipped with a built-in guide. Please refer to the graphs shown in P.127 and after for the allowable load mass.
- When performing push-motion operation, please confirm the push force of each model by checking the "Correlation diagram of push force and current limit" on P.113.
- For RCP6S (built-in controller type), please limit the duty cycle to 70% or less.
- The service life of an actuator with lead 5 varies depending on the payload when using vertically. Please refer to P. 114 for more information.

Correlation Diagrams of Speed and Payload

PCON connected.

RCP6(S)-WRA16C Horizontal mount

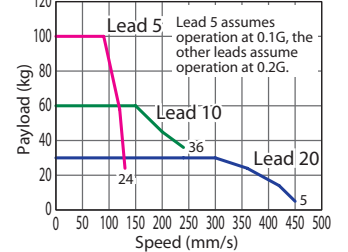

RCP6(S)-WRA16C Vertical mount

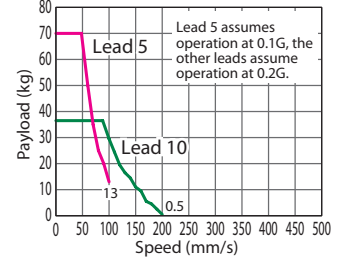

Actuator Specifications

Lead and Payload

(**) The payload assumes that there is an external guide.

Model Number	Lead (mm)	Max. Payload (kg)**		Stroke (mm)
		Horizontal	Vertical	
RCP6(S)-WRA16C-WA-60P-20-①-②-③-④	20	30	-	50~800 (The increment of stroke is 50mm)
RCP6(S)-WRA16C-WA-60P-10-①-②-③-④	10	60	36.5	
RCP6(S)-WRA16C-WA-60P-5-①-②-③-④	5	100	70	

Legend: ① Stroke ② Applicable controller/I/O type ③ Cable length ④ Options

Stroke and Max. Speed

(Unit: mm/s)

Lead (mm)	50 (mm)	100 (mm)	150~400 (mm)	450 (mm)	500 (mm)	550 (mm)	600 (mm)	650 (mm)	700 (mm)	750 (mm)	800 (mm)
20	280	405	450	400	340	295	260	225	200	180	
10	240 <200>		230 <200>	195	165	145	125	110	100	90	
5	130 <100>		115 <100>	95	80	70	60	55	50	45	

Values in brackets < > are for vertical use.

Cable Length

Cable Type	Cable Code
Standard	P (1m)
	S (3m)
	M (5m)
Specified Length	X06 (6m) ~ X10 (10m)
	X11 (11m) ~ X15 (15m)
	X16 (16m) ~ X20 (20m)
	R01 (1m) ~ R03 (3m)
Robot Cable	R04 (4m) ~ R05 (5m)
	R06 (6m) ~ R10 (10m)
	R11 (11m) ~ R15 (15m)
	R16 (16m) ~ R20 (20m)

* Refer to P.144 for more information regarding the maintenance cables.

Options

Name	Option Code	Reference Page
Brake	B	See P.105
Cable exit direction (Top)	CJT	See P.105
Cable exit direction (Right)	CJR	See P.105
Cable exit direction (Left)	CJL	See P.105
Cable exit direction (Bottom)	CJB	See P.105
Flange	FL	See P.106
Non-motor end specification	NM	See P.110
T-slot nut bar (Left)	NTBL	See P.110
T-slot nut bar (Right)	NTBR	See P.110

Actuator Specifications

Item	Description
Drive system	Ball screw ø16mm, rolled C10
Positioning repeatability	±0.01mm
Lost motion	0.1mm or less
Rod	ø45mm Stainless steel
Rod non-rotation precision (*)	0 deg.
Allowable load and torque on rod tip	See P. 129
Rod tip offset/overhang distance	dx: 150mm or less / dz: 100mm or less
Ambient operating temp. & humidity	0~40°C, 85% RH or less (Non-condensing)

(*) Rod's angular displacement in rotational direction with no load applied to the rod.

Offset distance at end of rod (dx: 150mm or less)

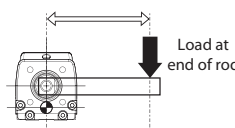

Overhang distance at end of rod (dz: 100mm or less)

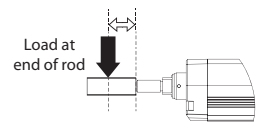

Dimensions

CAD drawings can be downloaded from our website.
www.robocylinder.de



*1 When the rod is returning to its home position, please be careful of interference from surrounding objects, as it will travel until it reaches the M.E. M.E: Mechanical end S.E: Stroke end
*2 When the overhang is large or severe adjustment of the angle is required, please attach the fittings without using the reamed hole.

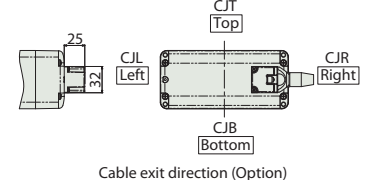
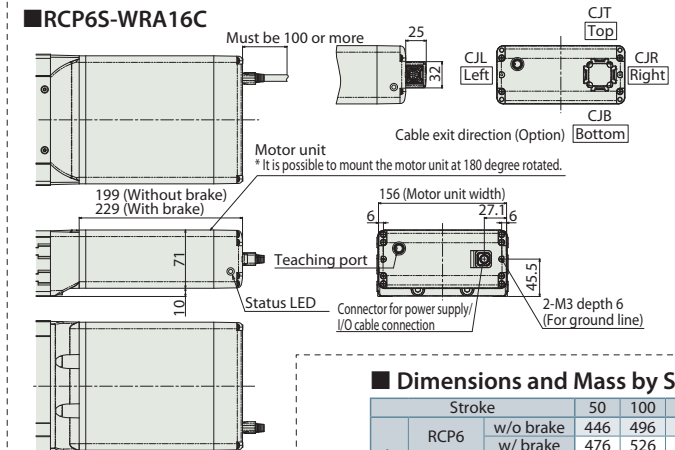
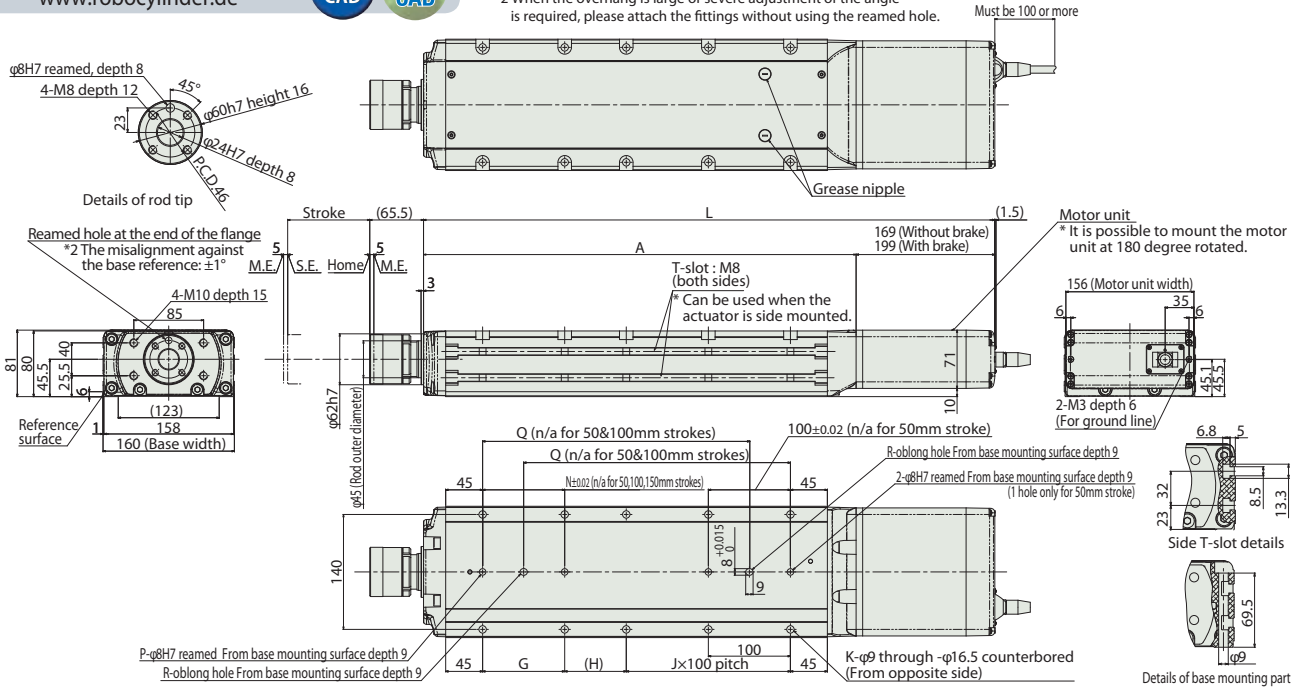

■ Rod Deflection of RCP6(S)-WRA16C (Reference Values)

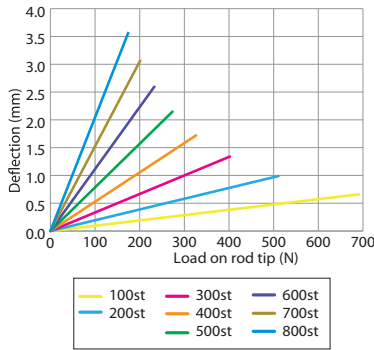

■ Dimensions and Mass by Stroke

L	Stroke	Stroke															
		50	100	150	200	250	300	350	400	450	500	550	600	650	700	750	800
RCP6S	w/o brake	446	496	546	596	646	696	746	796	846	896	946	996	1,046	1,096	1,146	1,196
	w/ brake	476	526	576	626	676	726	776	826	876	926	976	1,026	1,076	1,126	1,176	1,226
	w/o brake	476	526	576	626	676	726	776	826	876	926	976	1,026	1,076	1,126	1,176	1,226
	w/ brake	506	556	606	656	706	756	806	856	906	956	1,006	1,056	1,106	1,156	1,206	1,256
RCP6	A	277	327	377	427	477	527	577	627	677	727	777	827	877	927	977	1,027
	G	-	-	-	100	100	100	100	100	100	100	100	100	100	100	100	100
	H	125	75	125	75	125	75	125	75	125	75	125	75	125	75	125	75
	J	0	1	1	1	1	2	2	3	3	4	4	5	5	6	6	7
	K	4	6	6	8	8	10	10	12	12	14	14	16	16	18	18	20
	N	-	-	-	100	100	100	100	100	100	100	100	100	100	100	100	100
	P	1	1	1	2	2	2	2	2	2	2	2	2	2	2	2	2
	Q	-	-	175	225	275	325	375	425	475	525	575	625	675	725	775	825
	R	0	0	1	1	1	1	1	1	1	1	1	1	1	1	1	1
	3,000km	Allowable static load on rod tip (N)	588	588	588	511	451	402	362	329	300	275	254	235	217	202	188
Allowable static torque on rod tip (N·m)		40	40	40	40	40	40	40	40	40	40	40	40	40	40	40	40
Allowable dynamic Load offset 0mm		255	220	191	168	149	134	120	109	99	90	81	74	67	61	55	50
Allowable dynamic torque on rod tip (N·m)		133	133	133	133	133	122	111	101	92	84	77	70	64	58	53	48
5,000km	Allowable static load on rod tip (N)	20.0	20.0	20.0	20.0	20.0	18.3	16.7	15.2	13.8	12.6	11.5	10.5	9.6	8.7	7.9	7.1
	Allowable static torque on rod tip (N·m)	214	184	160	140	124	111	99	89	80	72	65	59	53	47	42	37
	Allowable dynamic Load offset 100mm	133	133	133	124	112	101	91	83	75	68	62	56	50	45	40	36
	Allowable dynamic torque on rod tip (N·m)	20.0	20.0	20.0	18.6	16.8	15.2	13.7	12.4	11.3	10.2	9.2	8.4	7.5	6.8	6.0	5.3
Mass (kg)	RCP6 w/o brake	11.5	12.6	13.7	14.9	16.0	17.1	18.3	19.4	20.5	21.7	22.8	23.9	25.1	26.2	27.3	28.5
	RCP6S w/o brake	12.0	13.1	14.3	15.4	16.5	17.6	18.8	19.9	21.1	22.2	23.3	24.5	25.6	26.7	27.9	29.0
	RCP6 w/ brake	11.6	12.7	13.9	15.0	16.2	17.3	18.4	19.5	20.7	21.8	23.0	24.1	25.2	26.3	27.5	28.6
	RCP6S w/ brake	12.1	13.3	14.4	15.5	16.7	17.8	18.9	20.1	21.2	22.3	23.5	24.6	25.8	26.9	28.0	29.1

Applicable Controllers

The RCP6 series actuators can be operated by the controllers indicated below. Please select the type depending on your intended use. * Please refer to P.147 for more information about the built-in controller of RCP6S series.

Name	External view	Max. number of controlled axes	Input power	Positioner	Pulse train	Program	Control method		Maximum number of positioning points	Reference page	
							Network *Option	Network *Option			
PCON-CFB/CGFB		1	DC24V	● *Option	● *Option	-	DeviceNet 	CompoNet 	EtherNet/IP 	512 (768 for network spec.)	Please see P.132

RCP6(S)-WRA10R

Battery-less Absolute
Motor Unit Coupled
Side-mounted Motor
Body Width 100* mm
24v Pulse Motor

Model Specification Items	Series	Type	Encoder Type	Motor Type	Lead	Stroke	Applicable Controller/I/O Type	Cable Length	Options
	—	WRA10R	WA	35P	—	—	—	—	—
	RCP6: Separate Controller RCP6S: Built-in Controller		WA: Battery-less Absolute	35P: Pulse Motor 35□ Size	16: 16mm 10: 10mm 5: 5mm 2.5: 2.5mm	50: 50mm 10: 10mm 500: 500mm (50mm increments)	[RCP6] P3: PCON MCON MSEL [RCP6S] SE: SIO Type	N : None P : 1m S : 3m M : 5m X□ : Specified Length R□ : Robot Cable	Please refer to the options table below. *Please make sure to specify either ML or MR when ordering the side-mounted motor type.

* RCP6 does not include a controller. RCP6S includes a built-in controller.

* Body width does not include the width of the side-mounted motor.

Radial Load OK

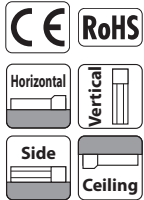

*Depending on the model, there may be some limitations to using the vertical, side, and ceiling mount positions. Please contact IAI for more information regarding mounting positions.

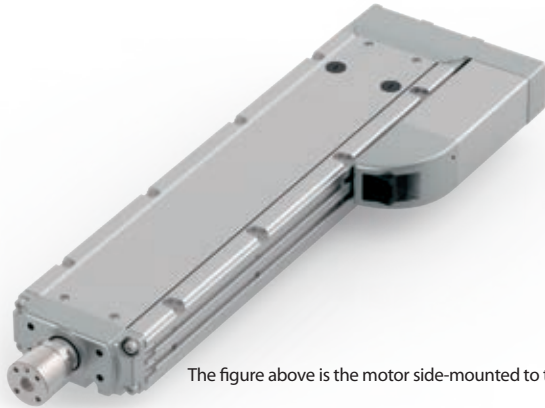

The figure above is the motor side-mounted to the left (ML).

- POINT Selection Notes**
- (1) The maximum acceleration/deceleration is 1G for horizontal, and 0.5G for vertical use.
 - (2) The actuator specification displays the payload's maximum value, but it will vary depending on the acceleration and speed. Please refer to the "Selection Guidelines" (RCP6 Tables of Payload by Speed/Acceleration) on P.115 for more details.
 - (3) The radial cylinder is equipped with a built-in guide. Please refer to the graphs shown in P.127 and after for the allowable load mass.
 - (4) When performing push-motion operation, please confirm the push force of each model by checking the "Correlation diagram of push force and current limit" on P.113.

Correlation Diagrams of Speed and Payload

High-output enabled (*) with PCON/MCON/MSEL connected.
RCP6(S)-WRA10R Horizontal mount

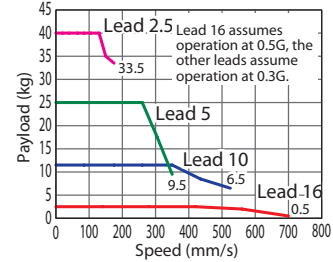

RCP6(S)-WRA10R Vertical mount

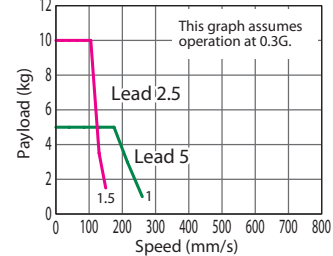

(*) For high output setting to OFF refer to the RCP6 manual.

Actuator Specifications (*)

(*) For values of disabled high output controller setting refer to the RCP6 manual.

Lead and Payload

(**) The payload assumes that there is an external guide.

Model Number	Lead (mm)	Connected Controller	Max. Payload		Stroke (mm)
			Horizontal (kg) (**)	Vertical (kg)	
RCP6(S)-WRA10R-WA-35P-16-①-②-③-④	16	High-output Enabled	4	-	50~500 (The increment of stroke is 50mm)
RCP6(S)-WRA10R-WA-35P-10-①-②-③-④	10	High-output Enabled	11.5	-	
RCP6(S)-WRA10R-WA-35P-5-①-②-③-④	5	High-output Enabled	28	5	
RCP6(S)-WRA10R-WA-35P-2.5-①-②-③-④	2.5	High-output Enabled	40	10	

Legend: ① Stroke ② Applicable controller/I/O type ③ Cable length ④ Options

Stroke and Max. Speed

(Unit: mm/s)

Lead (mm)	Connected Controller	50~400 (Every 50mm)	450 (mm)	500 (mm)
16	High-output Enabled	700		
10	High-output Enabled	525	490	
5	High-output Enabled	350 <260>	290 <260>	240
2.5	High-output Enabled	175 <150>	145	120

Values in brackets < > are for vertical use.

Cable Length

Cable Type	Cable Code
Standard	P (1m)
	S (3m)
	M (5m)
Specified Length	X06 (6m) ~ X10 (10m)
	X11 (11m) ~ X15 (15m)
	X16 (16m) ~ X20 (20m)
	R01 (1m) ~ R03 (3m)
Robot Cable	R04 (4m) ~ R05 (5m)
	R06 (6m) ~ R10 (10m)
	R11 (11m) ~ R15 (15m)
	R16 (16m) ~ R20 (20m)
	R16 (16m) ~ R20 (20m)

* Refer to P.144 for more information regarding the maintenance cables.

Options

Name	Option Code	Reference Page
Brake	B	See P.105
Cable exit direction (Outside)	CJO	See P.105
Flange	FL	See P.106
Motor side-mounted to the left	ML	See P.109
Motor side-mounted to the right	MR	See P.109
Non-motor end specification	NM	See P.110
T-slot nut bar (Left) (*)	NTBL	See P.110
T-slot nut bar (Right) (*)	NTBR	See P.110

Actuator Specifications

Item	Description
Drive system	Ball screw ø8mm, rolled C10
Positioning repeatability	±0.01mm
Lost motion	0.1mm or less
Rod	ø25mm Stainless steel
Rod non-rotation precision (*)	0 deg.
Allowable load and torque on rod tip	See P.129
Rod tip offset/overhang distance	dx/dz: 100mm or less
Ambient operating temp. & humidity	0~40°C, 85% RH or less (Non-condensing)

(*) Rod's angular displacement in rotational direction with no load applied to the rod.

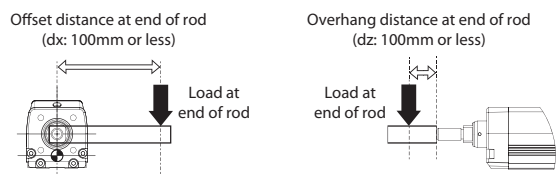

(*) When selecting T-slot nut bar with a side-mounted motor model, please choose NTBR when the motor is side-mounted to the left, and NTBL when the motor is side-mounted to the right.

Dimensions

CAD drawings can be downloaded from our website.
www.robocylinder.de



*1 When the rod is returning to its home position, please be careful of interference from surrounding objects, as it will travel until it reaches the M.E. M.E: Mechanical end S.E: Stroke end
*2 When the overhang is large or severe adjustment of the angle is required, please attach the fittings without using the reamed hole.

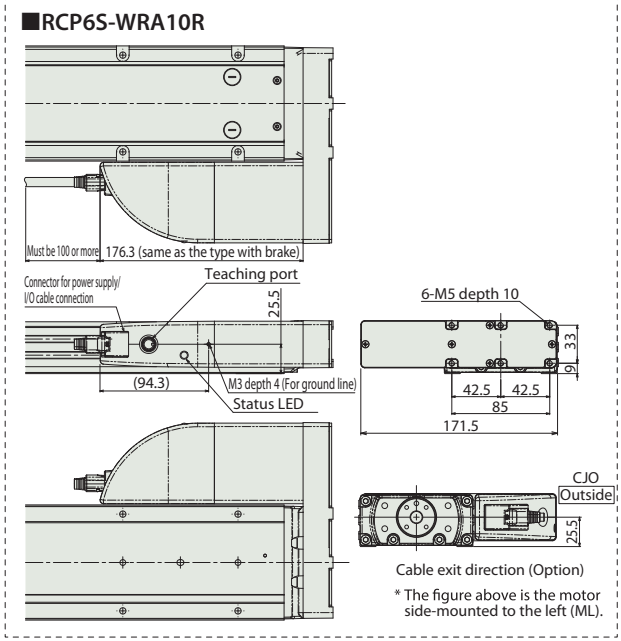
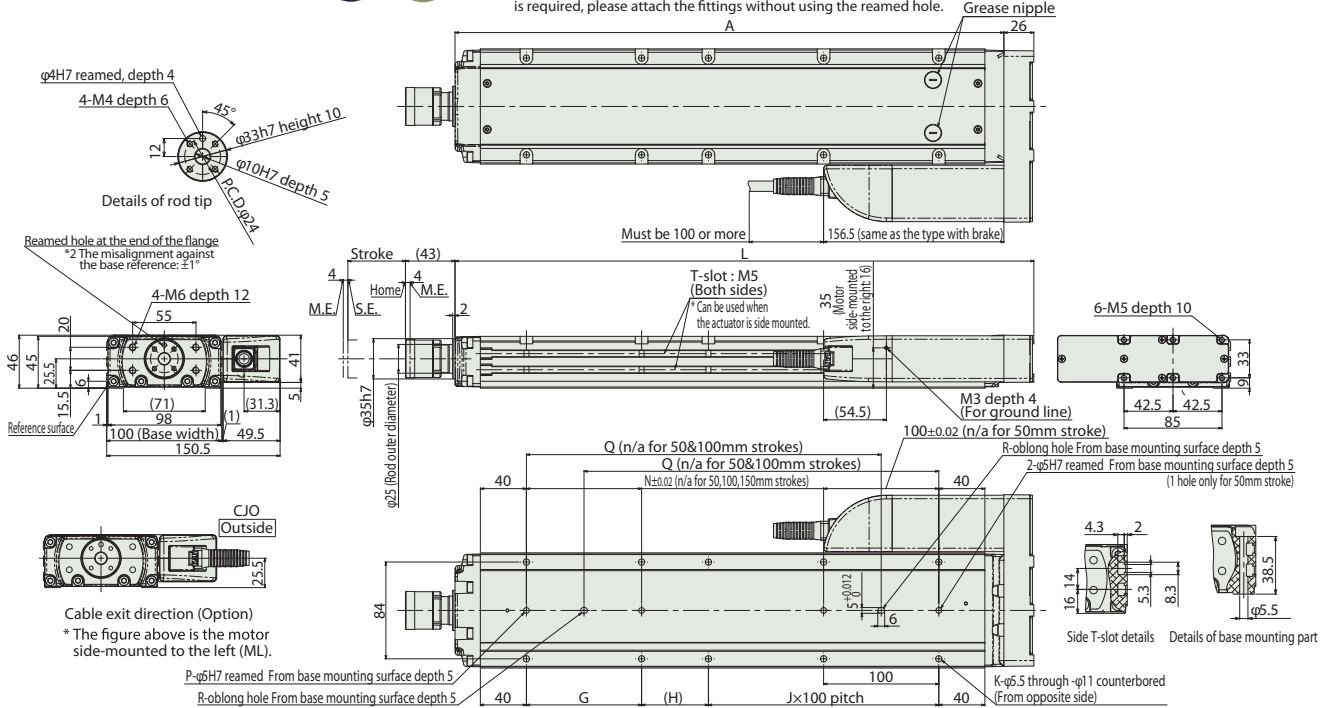

■ Rod Deflection of RCP6(S)-WRA10R (Reference Values)

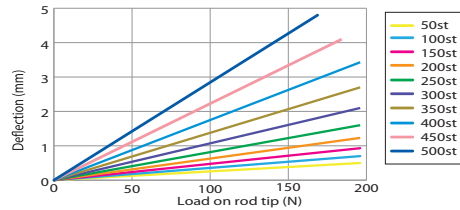

■ Dimensions and Mass by Stroke

Stroke	50	100	150	200	250	300	350	400	450	500
L	252.5	302.5	352.5	402.5	452.5	502.5	552.5	602.5	652.5	702.5
A	226.5	276.5	326.5	376.5	426.5	476.5	526.5	576.5	626.5	676.5
G	-	-	-	100	100	100	100	100	100	100
H	108	58	108	58	108	58	108	58	108	58
J	0	1	1	1	1	2	2	3	3	4
K	4	6	6	8	8	10	10	12	12	14
N	-	-	-	100	100	100	100	100	100	100
P	1	1	1	2	2	2	2	2	2	2
Q	-	-	158	208	258	308	358	408	458	508
R	0	0	1	1	1	1	1	1	1	1
Allowable static torque on rod tip (N)	196	196	196	196	196	196	196	196	184	169
Allowable static torque on rod tip (N·m)	10	10	10	10	10	10	10	10	10	10
3,000km	Allowable dynamic load on rod tip (N)	98	98	98	95	85	76	68	62	57
	Load offset 100mm	50	50	50	50	50	50	50	50	49
5,000km	Allowable dynamic torque on rod tip (N·m)	5.0	5.0	5.0	5.0	5.0	5.0	5.0	5.0	4.9
	Load offset 100mm	98	98	91	80	71	63	57	52	47
Mass (kg)	RCP6 w/o brake	3.4	3.8	4.3	4.7	5.2	5.6	6.1	6.5	7.0
	w/ brake	3.5	3.9	4.4	4.8	5.3	5.7	6.1	6.6	7.0
RCP6S	w/o brake	3.5	4.0	4.4	4.9	5.3	5.8	6.2	6.6	7.1
	w/ brake	3.6	4.0	4.5	4.9	5.4	5.8	6.3	6.7	7.2

Applicable Controllers

The RCP6 series actuators can be operated by the controllers indicated below. Please select the type depending on your intended use. * Please refer to P.147 for more information about the built-in controller of RCP6S series.

Name	External view	Max. number of controlled axes	Input power	Control method				Maximum number of positioning points	Reference page
				Positioner	Pulse train	Program	Network *Option		
PCON-CB/CGB		1	DC24V	● *Option	● *Option	-	 	512 (768 for network spec.)	Please see P.132
MCON-C/CG		4		This model is network-compatible only.					
MSEL-PC/PG		4	Single-phase 100~230VAC	-	-	●	Note: The type of compatible networks will vary depending on the controller. Please refer to reference page for more information.	30000	Please see the MSEL-PC/PG catalog or manual.

*Please select "high-output specification" as an option for the MCON. With the MCON, operation is possible only when the high-output specification is selected.

RCP6(S)-WRA12R

Battery-less Absolute
Motor Unit Coupled
Side-mounted Motor
Body Width 120* mm
24v Pulse Motor

Model Specification Items	Series	Type	Encoder Type	Motor Type	Lead	Stroke	Applicable Controller/I/O Type	Cable Length	Options
	□	—	WA	42P	□	□	□	□	□
	□	—	WA	42P	□	□	□	□	□
	RCP6: Separate Controller RCP6S: Built-in Controller		WA: Battery-less Absolute	42P: Pulse Motor 42□ Size	20: 20mm 12: 12mm 6: 6mm 3: 3mm	50: 50mm 1 500: 500mm (50mm increments)	[RCP6] P3: PCON MCON MSEL [RCP6S] SE: SIO Type	N : None P : 1m S : 3m M : 5m X□□ : Specified Length R□□ : Robot Cable	*Body width does not include the width of the side-mounted motor. Please refer to the options table below. *Please make sure to specify either ML or MR when ordering the side-mounted motor type.

* RCP6 does not include a controller. RCP6S includes a built-in controller.

Radial Load OK

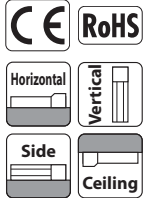

*Depending on the model, there may be some limitations to using the vertical, side, and ceiling mount positions. Please contact IAI for more information regarding mounting positions.



The figure above is the motor side-mounted to the left (ML).



- (1) The maximum acceleration/deceleration is 1G for horizontal, and 0.5G for vertical use.
- (2) The actuator specification displays the payload's maximum value, but it will vary depending on the acceleration and speed. Please refer to the "Selection Guidelines" (RCP6 Tables of Payload by Speed/Acceleration) on P.115 for more details.
- (3) The radial cylinder is equipped with a built-in guide. Please refer to the graphs shown in P.127 and after for the allowable load mass.
- (4) When performing push-motion operation, please confirm the push force of each model by checking the "Correlation diagram of push force and current limit" on P.113.
- (5) Depending on the ambient operational temperature, duty control is necessary for the RCP6S (built-in controller type) with lead 3/6. Please refer to P.130 for more information.

Correlation Diagrams of Speed and Payload

High-output enabled (*) with PCON/MCON/MSEL connected.
RCP6(S)-WRA12R Horizontal mount

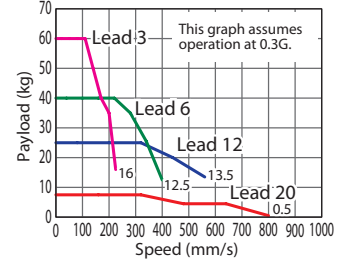

RCP6(S)-WRA12R Vertical mount

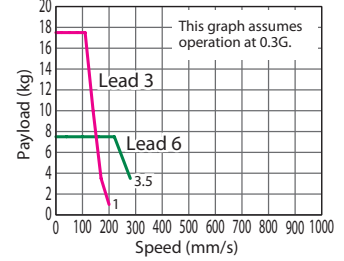

(*) For high output setting to OFF refer to the RCP6 manual.

Actuator Specifications (*)

(*) For values of disabled high output controller setting refer to the RCP6 manual.

Lead and Payload

(**) The payload assumes that there is an external guide.

Model Number	Lead (mm)	Connected Controller	Max. Payload		Stroke (mm)
			Horizontal (kg) (**)	Vertical (kg)	
RCP6(S)-WRA12R-WA-42P-20-①-②-③-④	20	High-output Enabled	7.5	-	50~500 (The increment of stroke is 50mm)
RCP6(S)-WRA12R-WA-42P-12-①-②-③-④	12	High-output Enabled	30	-	
RCP6(S)-WRA12R-WA-42P-6-①-②-③-④	6	High-output Enabled	55	7.5	
RCP6(S)-WRA12R-WA-42P-3-①-②-③-④	3	High-output Enabled	70	17.5	

Legend: ① Stroke ② Applicable controller/I/O type ③ Cable length ④ Options

Stroke and Max. Speed

(Unit: mm/s)

Lead (mm)	Connected Controller	50~400 (Every 50mm)	450 (mm)	500 (mm)
20	High-output Enabled		800	
12	High-output Enabled		560	
6	High-output Enabled	400 <280>		375 <280>
3	High-output Enabled	225 <200>	220 <200>	185

Values in brackets < > are for vertical use.

Cable Length

Cable Type	Cable Code
Standard	P (1m)
	S (3m)
	M (5m)
Specified Length	X06 (6m) ~ X10 (10m)
	X11 (11m) ~ X15 (15m)
	X16 (16m) ~ X20 (20m)
	R01 (1m) ~ R03 (3m)
Robot Cable	R04 (4m) ~ R05 (5m)
	R06 (6m) ~ R10 (10m)
	R11 (11m) ~ R15 (15m)
	R16 (16m) ~ R20 (20m)
	R16 (16m) ~ R20 (20m)

* Refer to P.144 for more information regarding the maintenance cables.

Options

Name	Option Code	Reference Page
Brake	B	See P.105
Cable exit direction (Outside)	CJO	See P.105
Flange	FL	See P.106
Motor side-mounted to the left	ML	See P.109
Motor side-mounted to the right	MR	See P.109
Non-motor end specification	NM	See P.110
T-slot nut bar (Left) (*)	NTBL	See P.110
T-slot nut bar (Right) (*)	NTBR	See P.110

Actuator Specifications

Item	Description
Drive system	Ball screw ø10mm, rolled C10
Positioning repeatability	±0.01mm
Lost motion	0.1mm or less
Rod	ø30mm Stainless steel
Rod non-rotation precision (*)	0 deg.
Allowable load and torque on rod tip	See P.129
Rod tip offset/overhang distance	dx/dz: 100mm or less
Ambient operating temp. & humidity	0~40°C, 85% RH or less (Non-condensing)

(*) Rod's angular displacement in rotational direction with no load applied to the rod.

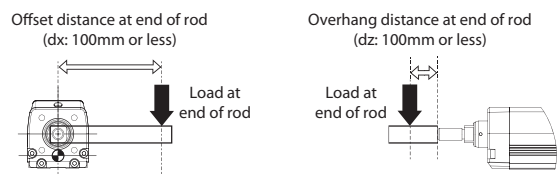

(*) When selecting T-slot nut bar option with a side-mounted motor model, please choose NTBR when the motor is side-mounted to the left, and NTBL when the motor is side-mounted to the right.

Dimensions

CAD drawings can be downloaded from our website.
www.robocylinder.de



*1 When the rod is returning to its home position, please be careful of interference from surrounding objects, as it will travel until it reaches the M.E.
M.E: Mechanical end S.E: Stroke end
*2 When the overhang is large or severe adjustment of the angle is required, please attach the fittings without using the reamed hole.

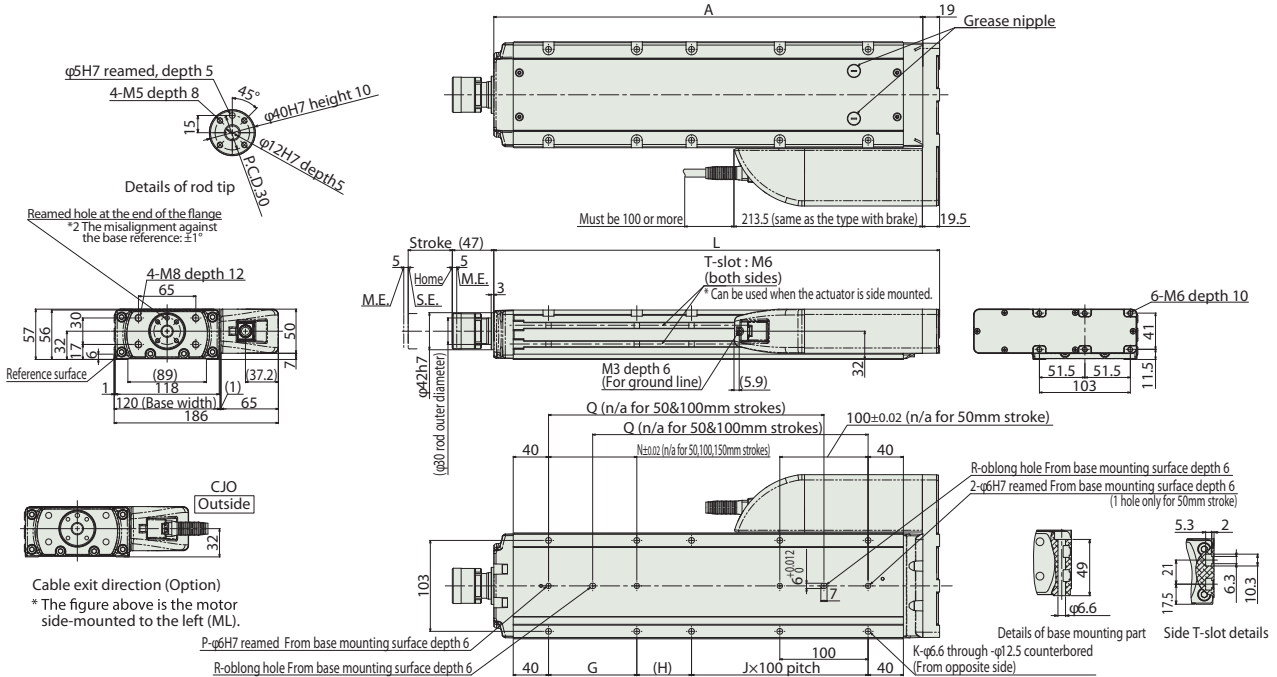

■ Rod Deflection of RCP6(S)-WRA12R (Reference Values)

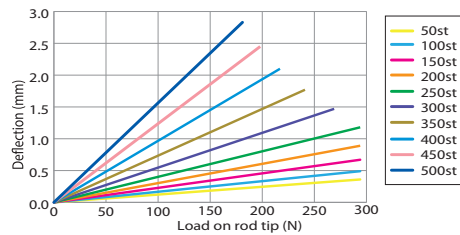

■ Dimensions and Mass by Stroke

Stroke	50	100	150	200	250	300	350	400	450	500	
L	255	305	355	405	455	505	555	605	655	705	
A	236	286	336	386	436	486	536	586	636	686	
G	-	-	-	100	100	100	100	100	100	100	
H	112	62	112	62	112	62	112	62	112	62	
J	0	1	1	1	1	2	2	3	3	4	
K	4	6	6	8	8	10	10	12	12	14	
N	-	-	-	100	100	100	100	100	100	100	
P	1	1	1	2	2	2	2	2	2	2	
Q	-	-	162	212	262	312	362	412	462	512	
R	0	0	1	1	1	1	1	1	1	1	
Allowable static load on rod tip (N)	294	294	294	294	294	269	241	218	198	181	
Allowable static torque on rod tip (N·m)	20	20	20	20	20	20	20	20	20	20	
3,000km	Allowable dynamic load on rod tip (N)	147	147	137	121	107	96	87	79	72	
	Allowable dynamic torque on rod tip (N·m)	10.0	10.0	10.0	10.0	9.9	9.0	8.2	7.5	6.8	
5,000km	Allowable dynamic load on rod tip (N)	147	133	115	101	90	80	72	65	59	
	Allowable dynamic torque on rod tip (N·m)	10.0	10.0	10.0	9.2	8.3	7.5	6.8	6.2	5.6	
Mass (kg)	RCP6	w/o brake	5.1	5.7	6.3	7.0	7.6	8.2	8.9	9.5	10.2
		w/ brake	5.1	5.8	6.4	7.0	7.7	8.3	9.0	9.6	10.2
	RCP6S	w/o brake	5.2	5.8	6.5	7.1	7.7	8.4	9.0	9.6	10.3
		w/ brake	5.3	5.9	6.5	7.2	7.8	8.4	9.1	9.7	10.4

■ RCP6S-WRA12R

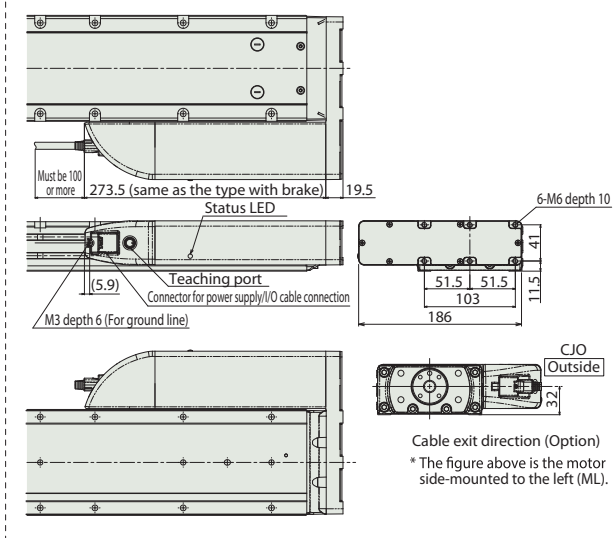

Applicable Controllers

The RCP6 series actuators can be operated by the controllers indicated below. Please select the type depending on your intended use. * Please refer to P.147 for more information about the built-in controller of RCP6S series.

Name	External view	Max. number of controlled axes	Input power	Control method				Maximum number of positioning points	Reference page
				Positioner	Pulse train	Program	Network *Option		
PCON-CB/CGB		1	DC24V	● *Option	● *Option	-	 	512 (768 for network spec.)	Please see P.132
MCON-C/CG		4		This model is network-compatible only.					
MSEL-PC/PG		4	Single-phase 100~230VAC	-	-	●	30000	Please see the MSEL-PC/PG catalog or manual.	

*Please select "high-output specification" as an option for the MCON. With the MCON, operation is possible only when the high-output specification is selected.

RCP6(S)-WRA14R

Battery-less Absolute

Motor Unit Coupled

Side-mounted Motor

Body Width 140* mm

24V Pulse Motor

Model Specification Items	Series	Type	Encoder Type	Motor Type	Lead	Stroke	Applicable Controller/I/O Type	Cable Length	Options
	—	WRA14R	WA	56P	—	—	—	—	—
	RCP6: Separate Controller RCP6S: Built-in Controller		WA: Battery-less Absolute	56P: Pulse Motor 56□ Size	24: 24mm 16: 16mm 8: 8mm 4: 4mm	50: 50mm 1 600: 600mm (50mm increments)	[RCP6] P3: PCON MCON MSEL [RCP6S] SE: SIO Type	N : None P : 1m S : 3m M : 5m X□□ : Specified Length R□□ : Robot Cable	* Body width does not include the width of the side-mounted motor. Please refer to the options table below. *Please make sure to specify either ML or MR when ordering the side-mounted motor type.

* RCP6 does not include a controller. RCP6S includes a built-in controller.

Radial Load OK

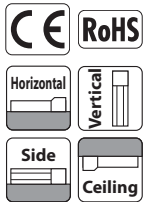

*Depending on the model, there may be some limitations to using the vertical, side, and ceiling mount positions. Please contact IAI for more information regarding mounting positions.

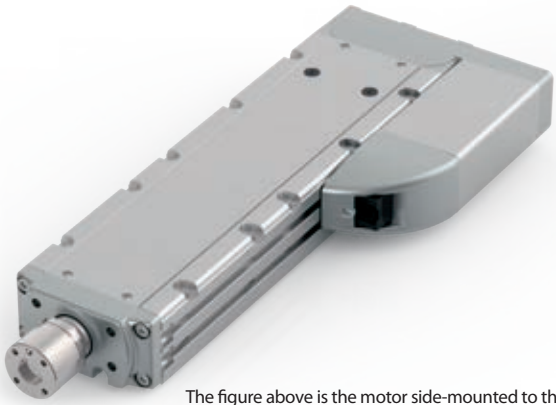

The figure above is the motor side-mounted to the left (ML).

- POINT Selection Notes**
- (1) The maximum acceleration/deceleration is 1G for horizontal, and 0.5G for vertical use.
 - (2) The actuator specification displays the payload's maximum value, but it will vary depending on the acceleration and speed. Please refer to the "Selection Guidelines" (RCP6 Tables of Payload by Speed/Acceleration) on P.115 for more details.
 - (3) The radial cylinder is equipped with a built-in guide. Please refer to the graphs shown in P.127 and after for the allowable load mass.
 - (4) When performing push-motion operation, please confirm the push force of each model by checking the "Correlation diagram of push force and current limit" on P.113.
 - (5) Depending on the ambient operational temperature, duty control is necessary for the RCP6S (built-in controller type) with lead 4/8/16. Please refer to P.130 for more information.

Correlation Diagrams of Speed and Payload

High-output enabled (*) with PCON/MCON/MSEL connected.
RCP6(S)-WRA14R Horizontal mount

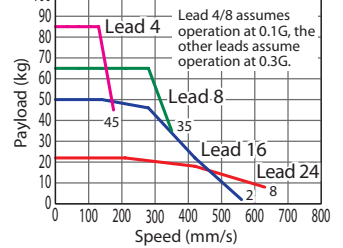

RCP6(S)-WRA14R Vertical mount

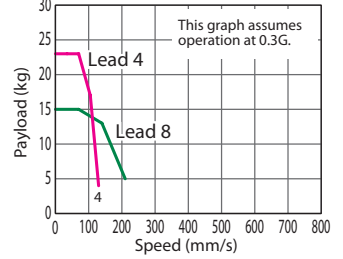

(*) For high output setting to OFF, refer to the RCP6 manual.

Actuator Specifications (*)

Lead and Payload					Stroke and Max. Speed			
Model Number	Lead (mm)	Connected Controller	Max. Payload		Stroke (mm)	Lead (mm)	Connected Controller	50~600 (Every 50mm)
			Horizontal (kg) (*)	Vertical (kg)				
RCP6(S)-WRA14R-WA-56P-24-①-②-③-④	24	High-output Enabled	25	-	50~600 (The increment of stroke is 50mm)	24	High-output Enabled	630
RCP6(S)-WRA14R-WA-56P-16-①-②-③-④	16	High-output Enabled	50	-		16	High-output Enabled	560
RCP6(S)-WRA14R-WA-56P-8-①-②-③-④	8	High-output Enabled	65	15		8	High-output Enabled	350 <210>
RCP6(S)-WRA14R-WA-56P-4-①-②-③-④	4	High-output Enabled	85	25		4	High-output Enabled	175 <130>

Legend: ① Stroke ② Applicable controller/I/O type ③ Cable length ④ Options

(**) The payload assumes that there is an external guide. (Unit: mm/s)

(*) For values of disabled high output controller setting refer to the RCP6 manual. Values in brackets < > are for vertical use.

Cable Length

Cable Type	Cable Code
Standard	P (1m)
	S (3m)
	M (5m)
Specified Length	X06 (6m) ~ X10 (10m)
	X11 (11m) ~ X15 (15m)
	X16 (16m) ~ X20 (20m)
	R01 (1m) ~ R03 (3m)
Robot Cable	R04 (4m) ~ R05 (5m)
	R06 (6m) ~ R10 (10m)
	R11 (11m) ~ R15 (15m)
	R16 (16m) ~ R20 (20m)

* Refer to P.144 for more information regarding the maintenance cables.

Options

Name	Option Code	Reference Page
Brake	B	See P.105
Cable exit direction (Outside)	CJO	See P.105
Flange	FL	See P.106
Motor side-mounted to the left	ML	See P.109
Motor side-mounted to the right	MR	See P.109
Non-motor end specification	NM	See P.110
T-slot nut bar (Left) (*)	NTBL	See P.110
T-slot nut bar (Right) (*)	NTBR	See P.110

Actuator Specifications

Item	Description
Drive system	Ball screw ø12mm, rolled C10
Positioning repeatability	±0.01mm
Lost motion	0.1mm or less
Rod	ø40mm Stainless steel
Rod non-rotation precision (*)	0 deg.
Allowable load and torque on rod tip	See P.129
Rod tip offset/overhang distance	dx: 150mm or less / dz: 100mm or less
Ambient operating temp. & humidity	0~40°C, 85% RH or less (Non-condensing)

(*) Rod's angular displacement in rotational direction with no load applied to the rod.

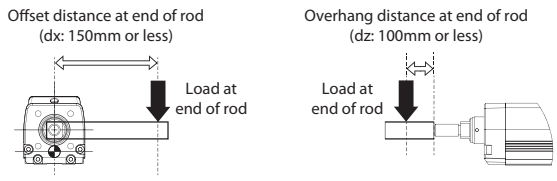

(*) When selecting T-slot nut bar option with a side-mounted motor model, please choose NTBR when the motor is side-mounted to the left, and NTBL when the motor is side-mounted to the right.

Dimensions

CAD drawings can be downloaded from our website.
www.roboCylinder.de



*1 When the rod is returning to its home position, please be careful of interference from surrounding objects, as it will travel until it reaches the M.E.
M.E: Mechanical end S.E: Stroke end
*2 When the overhang is large or severe adjustment of the angle is required, please attach the fittings without using the reamed hole.

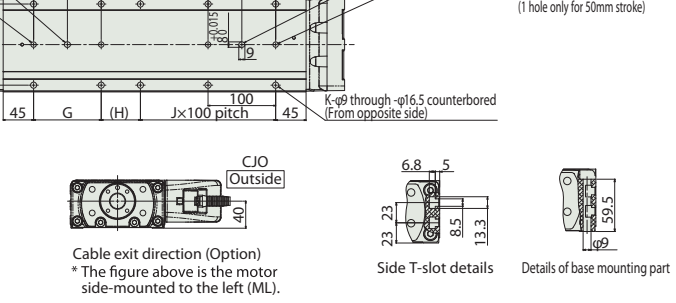
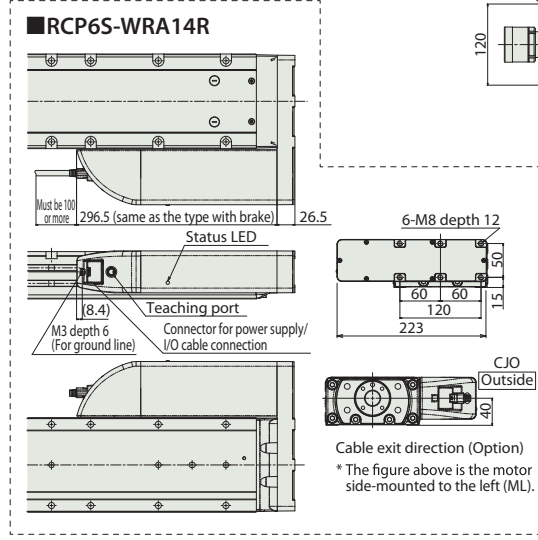
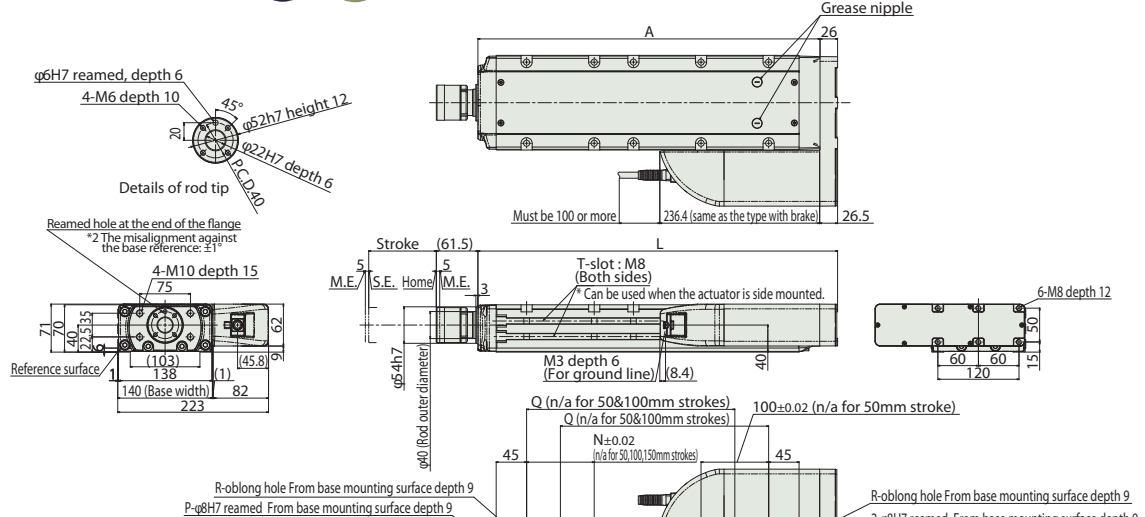

■ Rod Deflection of RCP6(S)-WRA14R (Reference Values)

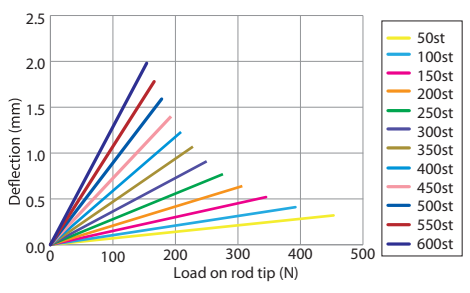

■ Dimensions and Mass by Stroke

Stroke	50	100	150	200	250	300	350	400	450	500	550	600	
L	282	332	382	432	482	532	582	632	682	732	782	832	
A	256	306	356	406	456	506	556	606	656	706	756	806	
G	-	-	-	100	100	100	100	100	100	100	100	100	
H	108	58	108	58	108	58	108	58	108	58	108	58	
J	0	1	1	1	1	2	2	3	3	4	4	5	
K	4	6	6	8	8	10	10	12	12	14	14	16	
N	-	-	-	100	100	100	100	100	100	100	100	100	
P	1	1	1	2	2	2	2	2	2	2	2	2	
Q	-	-	158	208	258	308	358	408	458	508	558	608	
R	0	0	1	1	1	1	1	1	1	1	1	1	
Allowable static load on rod tip (N)	454	392	345	307	276	251	229	210	193	179	166	154	
Allowable static torque on rod tip (N-m)	30	30	30	30	30	30	30	30	30	30	30	30	
3,000km	Allowable dynamic load on rod tip (N)	199	170	148	131	117	104	94	85	77	70	64	
	Allowable dynamic torque on rod tip (N-m)	15.0	15.0	15.0	15.0	15.0	14.3	13.0	11.8	10.8	9.9	9.0	
5,000km	Allowable dynamic load on rod tip (N)	167	143	124	109	97	87	78	70	63	57	51	
	Allowable dynamic torque on rod tip (N-m)	15.0	15.0	15.0	14.4	13.0	11.8	10.7	9.7	8.8	8.0	7.3	
Mass (kg)	RCP6	w/o brake	8.7	9.6	10.5	11.4	12.2	13.1	14.0	14.9	15.7	16.6	17.5
		w/ brake	8.9	9.7	10.6	11.5	12.4	13.2	14.1	15.0	15.9	16.7	17.6
	RCP6S	w/o brake	8.9	9.8	10.7	11.5	12.4	13.3	14.2	15.0	15.9	16.8	17.7
		w/ brake	9.0	9.9	10.8	11.6	12.5	13.4	14.3	15.2	16.0	16.9	17.8

Applicable Controllers

The RCP6 series actuators can be operated by the controllers indicated below. Please select the type depending on your intended use. * Please refer to P.147 for more information about the built-in controller of RCP6S series.

Name	External view	Max. number of controlled axes	Input power	Control method				Maximum number of positioning points	Reference page
				Positioner	Pulse train	Program	Network *Option		
PCON-CB/CGB		1	DC24V	●	●	-	 	512 (768 for network spec.)	Please see P.132
MCON-C/CG		4		This model is network-compatible only.					
MSEL-PC/PG		4	Single-phase 100~230VAC	-	-	●	Note: The type of compatible networks will vary depending on the controller. Please refer to reference page for more information.	30000	Please see the MSEL-PC/PG catalog or manual.

*Please select "high-output specification" as an option for the MCON. With the MCON, operation is possible only when the high-output specification is selected.

RCP6(S)-WRA16R

Battery-less Absolute
Motor Unit Coupled
Side-mounted Motor
Body Width 160* mm
24v Pulse Motor

Model Specification Items	Series	Type	Encoder Type	Motor Type	Lead	Stroke	Applicable Controller/I/O Type	Cable Length	Options
	—	—	—	—	—	—	—	—	—
	RCP6: Separate Controller RCP6S: Built-in Controller	WRA16R	WA	60P: Pulse Motor 60□ Size	20: 20mm 10: 10mm 5: 5mm	50: 50mm 1 800: 800mm (50mm increments)	[RCP6] P4: PCON- CFB/CGFB [RCP6S] SE: SIO Type	N : None P : 1m S : 3m M : 5m X□□ : Specified Length R□□ : Robot Cable	Please refer to the options table below. *Please make sure to specify either ML or MR when ordering the side-mounted motor type.

* RCP6 does not include a controller. RCP6S includes a built-in controller.

* Body width does not include the width of the side-mounted motor.

Radial Load OK



*Depending on the model, there may be some limitations to using the vertical, side, and ceiling mount positions. Please contact IAI for more information regarding mounting positions.

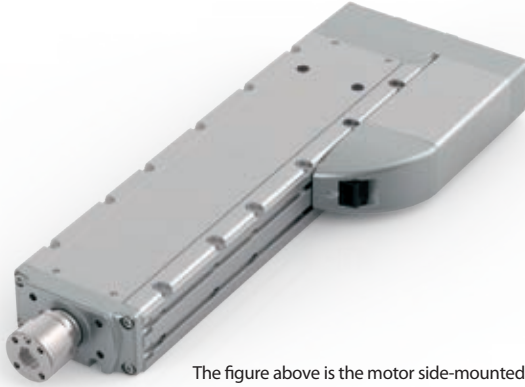

The figure above is the motor side-mounted to the left (ML).



- (1) The maximum acceleration/deceleration is 0.1G for lead 5 and 0.2G for lead 10/20.
- (2) The actuator specification displays the payload's maximum value, but it will vary depending on the acceleration and speed. Please refer to the "Selection Guidelines" (RCP6 Tables of Payload by Speed/Acceleration) on P.115 for more details.
- (3) The radial cylinder is equipped with a built-in guide. Please refer to the graphs shown in P.127 and after for the allowable load mass.
- (4) When performing push-motion operation, please confirm the push force of each model by checking the "Correlation diagram of push force and current limit" on P.113.
- (5) For RCP6S (built-in controller type), please limit the duty cycle to 70% or less.
- (6) The service life of an actuator with lead 5 varies depending on the payload when using vertically. Please refer to P. 114 for more information.

Correlation Diagrams of Speed and Payload

PCON connected.

RCP6(S)-WRA16R Horizontal mount

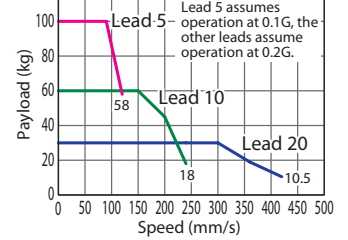

RCP6(S)-WRA16R Vertical mount

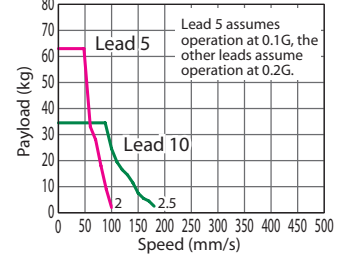

Actuator Specifications

Lead and Payload

(**) The payload assumes that there is an external guide.

Model Number	Lead (mm)	Max. Payload (kg)**		Stroke (mm)
		Horizontal	Vertical	
RCP6(S)-WRA16R-WA-60P-20-①-②-③-④	20	30	-	50~800 (The increment of stroke is 50mm)
RCP6(S)-WRA16R-WA-60P-10-①-②-③-④	10	60	34.5	
RCP6(S)-WRA16R-WA-60P-5-①-②-③-④	5	100	63	

Legend: ① Stroke ② Applicable controller/I/O type ③ Cable length ④ Options

Stroke and Max. Speed

(Unit: mm/s)

Lead (mm)	50 (mm)	100 (mm)	150~400 (mm)	450 (mm)	500 (mm)	550 (mm)	600 (mm)	650 (mm)	700 (mm)	750 (mm)	800 (mm)
20	280	405	420	400	340	295	260	225	200	180	
10	240 <180>		230 <180>	195	165	145	125	110	100	90	
5	120 <100>		115 <100>	95	80	70	60	55	50	45	

Values in brackets < > are for vertical use.

Cable Length

Cable Type	Cable Code
Standard	P (1m)
	S (3m)
	M (5m)
Specified Length	X06 (6m) ~ X10 (10m)
	X11 (11m) ~ X15 (15m)
	X16 (16m) ~ X20 (20m)
	R01 (1m) ~ R03 (3m)
Robot Cable	R04 (4m) ~ R05 (5m)
	R06 (6m) ~ R10 (10m)
	R11 (11m) ~ R15 (15m)
	R16 (16m) ~ R20 (20m)

* Refer to P.144 for more information regarding the maintenance cables.

Options

Name	Option Code	Reference Page
Brake	B	See P.105
Cable exit direction (Outside)	CJO	See P.105
Flange	FL	See P.106
Motor side-mounted to the left	ML	See P.109
Motor side-mounted to the right	MR	See P.109
Non-motor end specification	NM	See P.110
T-slot nut bar (Left) (*)	NTBL	See P.110
T-slot nut bar (Right) (*)	NTBR	See P.110

Actuator Specifications

Item	Description
Drive system	Ball screw ø16mm, rolled C10
Positioning repeatability	±0.01mm
Lost motion	0.1mm or less
Rod	ø45mm Stainless steel
Rod non-rotation precision (*)	0 deg.
Allowable load and torque on rod tip	See P. 129
Rod tip offset/overhang distance	dx: 150mm or less / dz: 100mm or less
Ambient operating temp. & humidity	0~40°C, 85% RH or less (Non-condensing)

(*) Rod's angular displacement in rotational direction with no load applied to the rod.

Offset distance at end of rod (dx: 150mm or less)

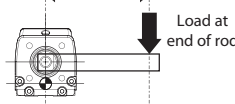

Overhang distance at end of rod (dz: 100mm or less)

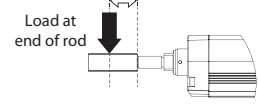

(*) When selecting T-slot nut bar option with a side-mounted motor model, please choose NTBR when the motor is side-mounted to the left, and NTBL when the motor is side-mounted to the right.

Dimensions

CAD drawings can be downloaded from our website.
www.robocylinder.de



*1 When the rod is returning to its home position, please be careful of interference from surrounding objects, as it will travel until it reaches the M.E.
M.E.: Mechanical end S.E.: Stroke end
*2 When the overhang is large or severe adjustment of the angle is required, please attach the fittings without using the reamed hole.

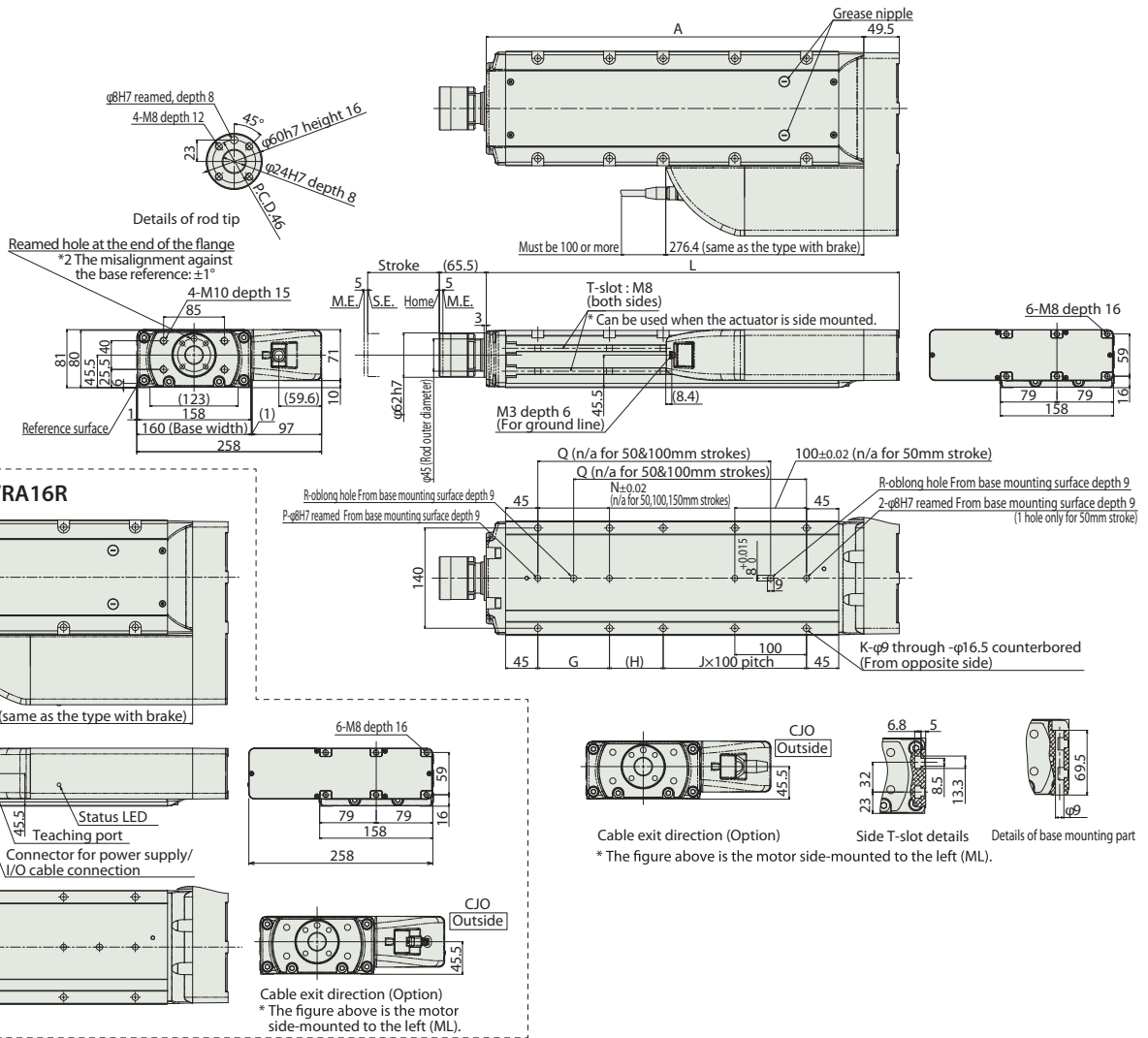

■ Rod Deflection of RCP6(S)-WRA16R (Reference Values)

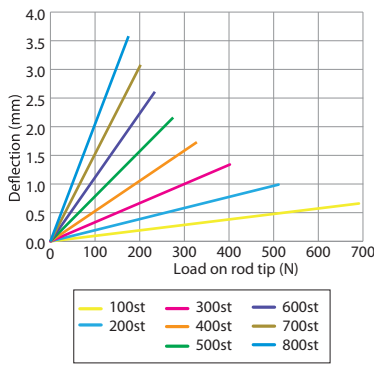

■ Dimensions and Mass by Stroke

Stroke	50	100	150	200	250	300	350	400	450	500	550	600	650	700	750	800
L	326.5	376.5	426.5	476.5	526.5	576.5	626.5	676.5	726.5	776.5	826.5	876.5	926.5	976.5	1,026.5	1,076.5
A	277	327	377	427	477	527	577	627	677	727	777	827	877	927	977	1,027
G	-	-	-	100	100	100	100	100	100	100	100	100	100	100	100	100
H	125	75	125	75	125	75	125	75	125	75	125	75	125	75	125	75
J	0	1	1	1	1	2	2	3	4	4	5	5	6	6	7	7
K	4	6	6	8	8	10	10	12	14	14	16	16	18	18	20	20
N	-	-	-	100	100	100	100	100	100	100	100	100	100	100	100	100
P	1	1	1	2	2	2	2	2	2	2	2	2	2	2	2	2
Q	-	-	175	225	275	325	375	425	475	525	575	625	675	725	775	825
R	0	0	1	1	1	1	1	1	1	1	1	1	1	1	1	1
Allowable static load on rod tip (N)	588	588	588	511	451	402	362	329	300	275	254	235	217	202	188	176
Allowable static torque on rod tip (N·m)	40	40	40	40	40	40	40	40	40	40	40	40	40	40	40	40
3,000km	Allowable dynamic load on rod tip (N)	255	220	191	168	149	134	120	109	99	90	81	74	67	61	55
	Load offset 100mm	133	133	133	133	133	122	111	101	92	84	77	70	64	58	53
5,000km	Allowable dynamic torque on rod tip (N·m)	20.0	20.0	20.0	20.0	20.0	18.3	16.7	15.2	13.8	12.6	11.5	10.5	9.6	8.7	7.9
	Load offset 100mm	214	184	160	140	124	111	99	89	80	72	65	59	53	47	42
Mass (kg)	RCP6 w/o brake	13.1	14.2	15.3	16.5	17.6	18.7	19.9	21.0	22.2	23.3	24.5	25.6	26.7	27.9	29.0
	RCP6S w/o brake	13.3	14.4	15.6	16.7	17.9	19.0	20.1	21.3	22.4	23.5	24.7	25.8	27.0	28.1	29.3
	RCP6 w/ brake	13.6	14.7	15.8	16.9	18.1	19.2	20.4	21.5	22.7	23.8	24.9	26.1	27.2	28.3	29.5
	RCP6S w/ brake	13.6	14.7	15.8	16.9	18.1	19.2	20.4	21.5	22.7	23.8	24.9	26.1	27.2	28.3	29.5

Applicable Controllers

The RCP6 series actuators can be operated by the controllers indicated below. Please select the type depending on your intended use. * Please refer to P.147 for more information about the built-in controller of RCP6S series.

Name	External view	Max. number of controlled axes	Input power	Positioner	Pulse train	Program	Control method		Maximum number of positioning points	Reference page	
							Network *Option	Network *Option			
PCON-CFB/CGFB		1	DC24V	*Option	*Option	-	DeviceNet 	CompoNet 	EtherNet/IP 	512 (768 for network spec.)	Please see P.132

RCP6(S)-TA4C

Table Type Motor Unit Coupled Straight Motor Body Width 40mm 24V Pulse Motor

Model Specification Items	Series	Type	Encoder Type	Motor Type	Lead	Stroke	Applicable Controller/I/O Type	Cable Length	Options
	RCP6: Separate Controller RCP6S: Built-in Controller	TA4C	WA: Battery-less Absolute	35P: Pulse Motor 35□ Size	16: 16mm 10: 10mm 5: 5mm 2.5: 2.5mm	25: 25mm 240: 240mm	[RCP6] P3: PCON MCON MSEL [RCP6S] SE: SIO Type	N: None P: 1m S: 3m M: 5m X□□: Specified Length R□□: Robot Cable	Please refer to the options table below.

* RCP6 does not include a controller. RCP6S includes a built-in controller.

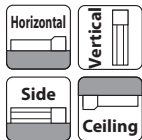

*Depending on the model, there may be some limitations to using the vertical, side, and ceiling mount positions. Please contact IAI for more information regarding mounting positions.



Correlation Diagrams of Speed and Payload

High-output enabled (*) with PCON/MCON/MSEL connected.

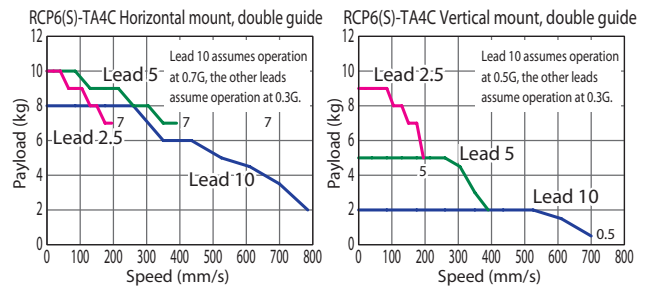
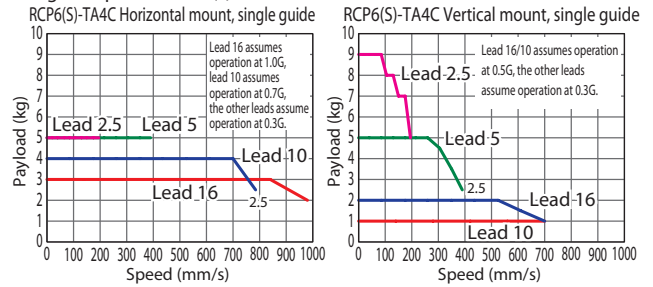

(*) For high output setting to OFF refer to the RCP6 manual.

- POINT Selection Notes**
- The maximum acceleration/deceleration is 1G for horizontal, and 0.5G for vertical use.
 - The actuator specification displays the payload's maximum value, but it will vary depending on the acceleration and speed. Please refer to the "Selection Guidelines" (RCP6 Tables of Payload by Speed/Acceleration) on P.115 for more details.
 - When performing push-motion operation, please confirm the push force of each model by checking the "Correlation diagram of push force and current limit" on P.113.
 - High-rigidity (double-block guide) specification can be selected as an option.

Actuator Specifications (*)

Lead and Payload					Stroke and Max. Speed (Unit: mm/s)					
Guide Type	Model Number	Lead (mm)	Connected Controller	Max. Payload		Stroke (mm)	Lead (mm)	Connected Controller	Max. Speed	
				Horizontal (kg)	Vertical (kg)				Single Guide (25~150)	Double Guide (40~190, 240)
Single Guide	RCP6(S)-TA4C-WA-35P-16-①-②-③-④	16	High-output Enabled	3	1	25~150 (The increment of stroke is 25mm)	16	High-output Enabled	980 <700>	-
	RCP6(S)-TA4C-WA-35P-10-①-②-③-④	10	High-output Enabled	4	2.5		10	High-output Enabled	785 <700>	785 <700> 680
	RCP6(S)-TA4C-WA-35P-5-①-②-③-④	5	High-output Enabled	5	5		5	High-output Enabled	390	390 340
	RCP6(S)-TA4C-WA-35P-2.5-①-②-③-④	2.5	High-output Enabled	5	10		2.5	High-output Enabled	195	195 170
Double Guide	RCP6(S)-TA4C-WA-35P-10-①-②-③-④	10	High-output Enabled	8	2.5	40/65/90~240 (The increment of stroke is 50mm)	16	High-output Enabled	980 <700>	-
	RCP6(S)-TA4C-WA-35P-5-①-②-③-④	5	High-output Enabled	10	5		10	High-output Enabled	785 <700>	785 <700> 680
	RCP6(S)-TA4C-WA-35P-2.5-①-②-③-④	2.5	High-output Enabled	10	10		5	High-output Enabled	390	390 340

Legend: ① Stroke ② Applicable controller/I/O type ③ Cable length ④ Options

(*) For values of disabled high output controller setting refer to the RCP6 manual.

Cable Length

Cable Type	Cable Code
Standard	P (1m)
	S (3m)
	M (5m)
Specified Length	X06 (6m) ~ X10 (10m)
	X11 (11m) ~ X15 (15m)
	X16 (16m) ~ X20 (20m)
Robot Cable	R01 (1m) ~ R03 (3m)
	R04 (4m) ~ R05 (5m)
	R06 (6m) ~ R10 (10m)
	R11 (11m) ~ R15 (15m)
	R16 (16m) ~ R20 (20m)
	R20 (20m)

* Refer to P.144 for more information regarding the maintenance cables.

Options

Name	Option Code	Reference Page
Brake	B	See P.105
Cable exit direction (Top)	CJT	See P.105
Cable exit direction (Right)	CJR	See P.105
Cable exit direction (Left)	CJL	See P.105
Cable exit direction (Bottom)	CJB	See P.105
High-rigidity (Double-block guide)	DB	See P.105
Non-motor end specification	NM	See P.110

Actuator Specifications

Item	Description
Drive system	Ball screw ø8mm, rolled C10
Positioning repeatability	±0.01mm
Lost motion	0.1mm or less
Base	Material: Aluminum with white alumite treatment
Static allowable moment	Single guide: Ma: 13N·m, Mb: 18.6N·m, Mc: 25.3N·m
	Double guide: Ma: 76.8N·m, Mb: 110N·m, Mc: 50.5N·m
Dynamic allowable moment (*)	Single guide: Ma: 4.98N·m, Mb: 7.11N·m, Mc: 9.68N·m
	Double guide: Ma: 23.9N·m, Mb: 34.1N·m, Mc: 15.7N·m
Ambient operating temperature & humidity	0~40°C, 85% RH or less (Non-condensing)

(*) Assumes a standard rated life of 5000km. The service life will vary depending on operation and installation conditions.

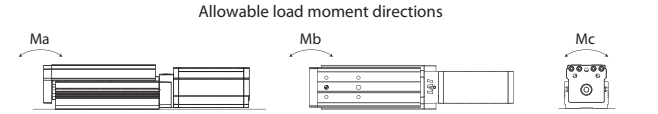

Please refer to the RoboCylinder General Catalog for more information regarding the directions of the allowable moment and overhang load length. Please refer to the RCP6 manual regarding the displacement of the table.

RCP6(S)-TA6C

Table Type Motor Unit Coupled Straight Motor Body Width 58 mm 24v Pulse Motor

Model Specification Items

Series	Type	Encoder Type	Motor Type	Lead	Stroke	Applicable Controller/I/O Type	Cable Length	Options
RCP6: Separate Controller RCP6S: Built-in Controller	TA6C	WA: Battery-less Absolute	42P: Pulse Motor 42□ Size	20: 20mm 12: 12mm 6: 6mm 3: 3mm	25: 25mm 320: 320mm	[RCP6] P3: PCON MCON MSEL [RCP6S] SE: SIO Type	N : None P : 1m S : 3m M : 5m X□ : Specified Length R□ : Robot Cable	Please refer to the options table below.

* RCP6 does not include a controller. RCP6S includes a built-in controller.

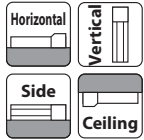

* Depending on the model, there may be some limitations to using the vertical, side, and ceiling mount positions. Please contact IAI for more information regarding mounting positions.



- POINT Selection Notes**
- (1) The maximum acceleration/deceleration is 1G for horizontal, and 0.5G for vertical use.
 - (2) The actuator specification displays the payload's maximum value, but it will vary depending on the acceleration and speed. Please refer to the "Selection Guidelines" (RCP6 Tables of Payload by Speed/Acceleration) on P.115 for more details.
 - (3) When performing push-motion operation, please confirm the push force of each model by checking the "Correlation diagram of push force and current limit" on P.113.
 - (4) Depending on the ambient operational temperature, duty control is necessary for the RCP6S (built-in controller type) with lead 3/6. Please refer to P.130 for more information.
 - (5) High-rigidity (double-block guide) specification can be selected as an option.

Correlation Diagrams of Speed and Payload

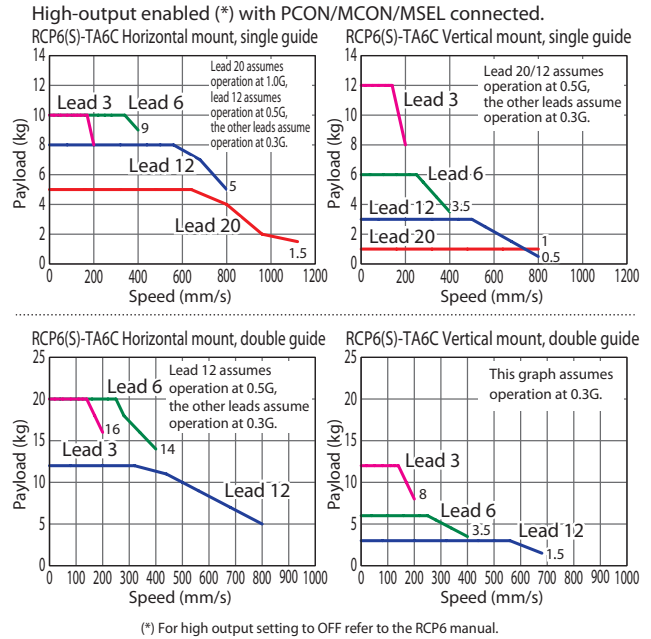

Actuator Specifications (*)

Lead and Payload

Model Number	Lead (mm)	Connected Controller	Max. Payload		Stroke (mm)
			Horizontal (kg)	Vertical (kg)	
RCP6(S)-TA6C-WA-42P-20-①-②-③-④	20	High-output Enabled	5	1	25~200 (The increment of stroke is 25mm)
RCP6(S)-TA6C-WA-42P-12-①-②-③-④	12	High-output Enabled	8	3	
RCP6(S)-TA6C-WA-42P-6-①-②-③-④	6	High-output Enabled	10	6	
RCP6(S)-TA6C-WA-42P-3-①-②-③-④	3	High-output Enabled	10	12	
RCP6(S)-TA6C-WA-42P-12-①-②-③-④	12	High-output Enabled	15	3	40/70/95/ 120~320 (The increment of stroke is 50mm)
RCP6(S)-TA6C-WA-42P-6-①-②-③-④	6	High-output Enabled	20	6	
RCP6(S)-TA6C-WA-42P-3-①-②-③-④	3	High-output Enabled	20	12	

Legend: ① Stroke ② Applicable controller/I/O type ③ Cable length ④ Options

Stroke and Max. Speed

Lead (mm)	Connected Controller	Max. Speed (Unit: mm/s)			
		Single Guide 25~200	Double Guide 45~220	270	320
20	High-output Enabled	1120 <800>	-	-	-
12	High-output Enabled	800	800 <680>	735 <680>	575
6	High-output Enabled	400	400	365	285
3	High-output Enabled	200	200	185	140

Values in brackets < > are for vertical use.

Cable Length

Cable Type	Cable Code
Standard	P (1m)
	S (3m)
	M (5m)
Specified Length	X06 (6m) ~ X10 (10m)
	X11 (11m) ~ X15 (15m)
	X16 (16m) ~ X20 (20m)
	R01 (1m) ~ R03 (3m)
Robot Cable	R04 (4m) ~ R05 (5m)
	R06 (6m) ~ R10 (10m)
	R11 (11m) ~ R15 (15m)
	R16 (16m) ~ R20 (20m)

* Refer to P.144 for more information regarding the maintenance cables.

Options

Name	Option Code	Reference Page
Brake	B	See P.105
Cable exit direction (Top)	CJT	See P.105
Cable exit direction (Right)	CJR	See P.105
Cable exit direction (Left)	CJL	See P.105
Cable exit direction (Bottom)	CJB	See P.105
High-rigidity (Double-block guide)	DB	See P.105
Non-motor end specification	NM	See P.110

Actuator Specifications

Item	Description
Drive system	Ball screw ø10mm, rolled C10
Positioning repeatability	±0.01mm
Lost motion	0.1mm or less
Base	Material: Aluminum with white alumite treatment
Static allowable moment	Single guide: Ma: 32.3N·m, Mb: 46.2N·m, Mc: 68.3N·m
	Double guide: Ma: 169N·m, Mb: 242N·m, Mc: 137N·m
Dynamic allowable moment (*)	Single guide: Ma: 11.6N·m, Mb: 16.6N·m, Mc: 24.6N·m
	Double guide: Ma: 49.5N·m, Mb: 70.7N·m, Mc: 40N·m
Ambient operating temperature & humidity	0~40°C, 85% RH or less (Non-condensing)

(*) Assumes a standard rated life of 5000km. The service life will vary depending on operation and installation conditions.

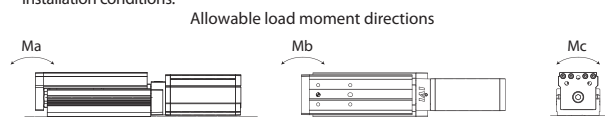

Please refer to the RoboCylinder General Catalog for more information regarding the directions of the allowable moment and overhang load length. Please refer to the RCP6 manual regarding the displacement of the table.

Dimensions

CAD drawings can be downloaded from our website.
www.robocylinder.de



*1 When the table is returning to its home position, please be careful of interference from surrounding objects, as it will travel until it reaches the M.E.
M.E: Mechanical end S.E: Stroke end

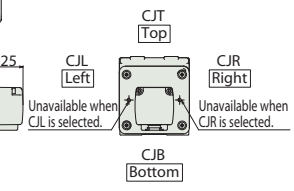
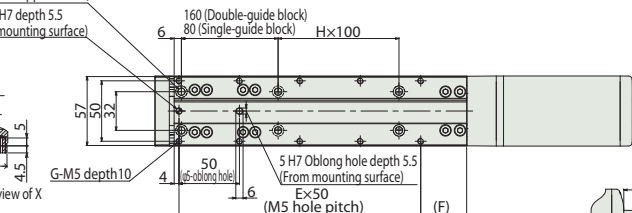
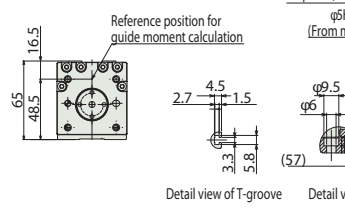
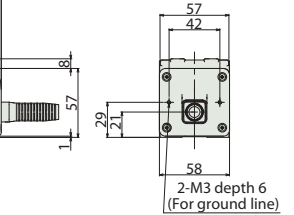
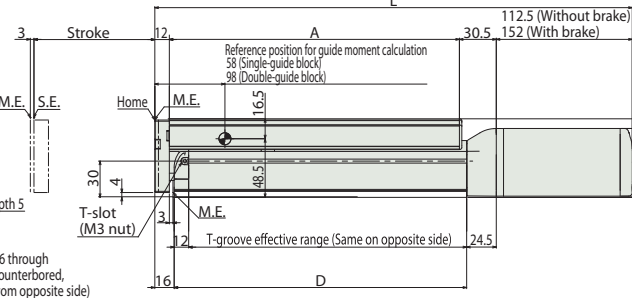
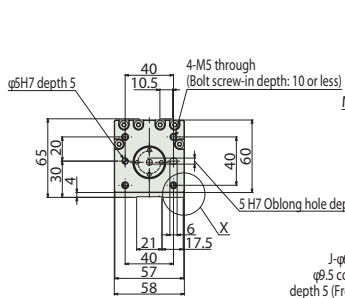
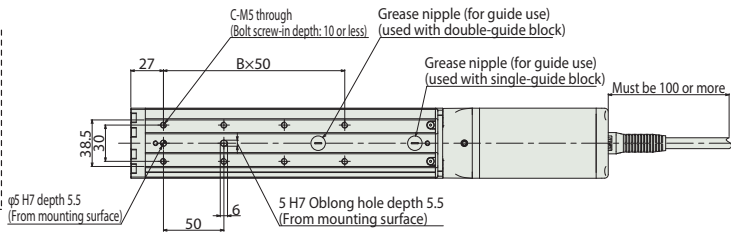
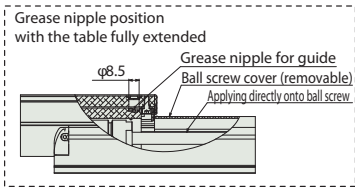

RCP6S-TA6C

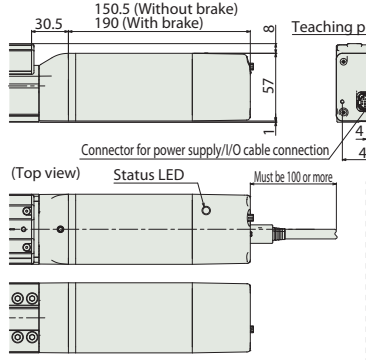

Dimensions and Mass by Stroke

Stroke	Single Guide																Double Guide																								
	25	50	75	100	125	150	175	200	45	70	95	120	170	220	270	320	45	70	95	120	170	220	270	320																	
L	RCP6 w/o brake	270	295	320	345	370	395	420	445	370	395	420	445	495	545	595	645	370	395	420	445	495	545	595	645																
	RCP6S w/o brake	309.5	334.5	359.5	384.5	409.5	434.5	459.5	484.5	509.5	408	433	458	483	533	583	633	683	408	433	458	483	533	583	633	683															
A	RCP6 w/o brake	347.5	372.5	397.5	422.5	447.5	472.5	497.5	522.5	447.5	472.5	497.5	522.5	572.5	622.5	672.5	722.5	447.5	472.5	497.5	522.5	572.5	622.5	672.5	722.5																
	RCP6S w/o brake	347.5	372.5	397.5	422.5	447.5	472.5	497.5	522.5	447.5	472.5	497.5	522.5	572.5	622.5	672.5	722.5	347.5	372.5	397.5	422.5	447.5	472.5	497.5	522.5	572.5	622.5	672.5	722.5												
B	115	140	165	190	215	240	265	290	215	240	265	290	340	390	440	490	215	240	265	290	340	390	440	490	215	240	265	290	215	240	265	290									
C	4	4	6	6	8	8	10	10	8	8	10	10	8	8	10	12	14	16	16	18	18	20	22	24	26	28	30	32	34	36	38	40									
D	117	142	167	192	217	242	267	292	217	242	267	292	342	392	442	492	217	242	267	292	342	392	442	492	217	242	267	292	217	242	267	292									
E	2	2	3	3	4	4	5	5	4	4	5	5	6	7	8	9	4	4	5	5	6	7	8	9	4	4	5	5	6	7	8	9									
F	13	38	13	38	13	38	13	38	13	38	13	38	13	38	38	38	13	38	13	38	13	38	13	38	13	38	13	38	13	38	13	38	13	38							
G	6	6	8	8	10	10	12	12	10	10	12	12	14	16	18	20	6	6	8	8	10	10	12	12	14	16	18	20	6	6	8	8	10	10							
H	0	0	0	0	1	1	1	1	0	0	0	0	1	1	2	2	0	0	0	0	1	1	2	2	0	0	0	0	0	0	0	0	0	0							
J	4	4	4	4	6	6	6	6	4	4	4	4	6	6	8	8	4	4	4	4	6	6	8	8	4	4	4	4	4	4	4	4	4	4							
Mass (kg)	RCP6 w/o brake	2.1	2.2	2.4	2.5	2.7	2.9	3.0	3.2	2.9	3.0	3.2	3.3	3.7	4.0	4.3	4.6	2.9	3.0	3.2	3.3	3.7	4.0	4.3	4.6	2.9	3.0	3.2	3.3	3.7	4.0	4.3	4.6								
	RCP6S w/o brake	2.2	2.4	2.5	2.7	2.8	3.0	3.2	3.3	3.0	3.2	3.3	3.4	3.6	3.9	4.2	4.5	4.9	3.0	3.2	3.3	3.4	3.6	3.9	4.2	4.5	4.9	3.0	3.2	3.3	3.4	3.6	3.9	4.2	4.5	4.9					
	RCP6 w/ brake	2.3	2.5	2.6	2.8	2.9	3.1	3.3	3.4	3.1	3.3	3.4	3.6	3.9	4.2	4.5	4.9	3.1	3.3	3.4	3.6	3.9	4.2	4.5	4.9	3.1	3.3	3.4	3.6	3.9	4.2	4.5	4.9	3.1	3.3	3.4	3.6	3.9	4.2	4.5	4.9
	RCP6S w/ brake	2.4	2.6	2.8	2.9	3.1	3.2	3.4	3.6	3.2	3.4	3.6	3.7	4.0	4.4	4.7	5.0	3.2	3.4	3.6	3.7	4.0	4.4	4.7	5.0	3.2	3.4	3.6	3.7	4.0	4.4	4.7	5.0	3.2	3.4	3.6	3.7	4.0	4.4	4.7	5.0

Applicable Controllers

The RCP6 series actuators can be operated by the controllers indicated below. Please select the type depending on your intended use. * Please refer to P.147 for more information about the built-in controller of RCP6S series.

Name	External view	Max. number of controlled axes	Input power	Control method				Maximum number of positioning points	Reference page
				Positioner	Pulse train	Program	Network *Option		
PCON-CB/CGB		1	DC24V	● *Option	● *Option	-	DeviceNet CC-Link EtherCAT EtherNet/IP CompoNet	512 (768 for network spec.)	Please see P.132
MCON-C/CG		4		This model is network-compatible only.					256
MSEL-PC/PG		4	Single-phase 100~230VAC	-	-	●	Note: The type of compatible networks will vary depending on the controller. Please refer to reference page for more information.	30000	Please see the MSEL-PC/PG catalog or manual.

* Please select "high-output specification" as an option for the MCON. With the MCON, operation is possible only when the high-output specification is selected.

RCP6(S)-TA7C

Table Type Motor Unit Coupled Straight Motor Body Width 70 mm 24v Pulse Motor

Model Specification Items	Series	Type	Encoder Type	Motor Type	Lead	Stroke	Applicable Controller/I/O Type	Cable Length	Options
	□	TA7C	WA	56P	□	□	□	□	□
	RCP6: Separate Controller RCP6S: Built-in Controller		WA: Battery-less Absolute	56P: Pulse Motor 56□ Size	24: 24mm 16: 16mm 8: 8mm 4: 4mm	25: 25mm 390: 390mm	[RCP6] P3: PCON MCON MSEL [RCP6S] SE: SIO Type	N : None P : 1m S : 3m M : 5m X□□ : Specified Length R□□ : Robot Cable	Please refer to the options table below.

* RCP6 does not include a controller. RCP6S includes a built-in controller.

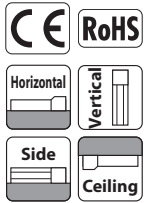

*Depending on the model, there may be some limitations to using the vertical, side, and ceiling mount positions. Please contact IAI for more information regarding mounting positions.

- POINT Selection Notes**
- (1) The maximum acceleration/deceleration is 1G for horizontal, and 0.5G for vertical use.
 - (2) The actuator specification displays the payload's maximum value, but it will vary depending on the acceleration and speed. Please refer to the "Selection Guidelines" (RCP6 Tables of Payload by Speed/Acceleration) on P.115 for more details.
 - (3) When performing push-motion operation, please confirm the push force of each model by checking the "Correlation diagram of push force and current limit" on P.113.
 - (4) Depending on the ambient operational temperature, duty control is necessary for the RCP6S (built-in controller type) with lead 4/8/16. Please refer to P.130 for more information.
 - (5) High-rigidity (double-block guide) specification can be selected as an option.

Correlation Diagrams of Speed and Payload

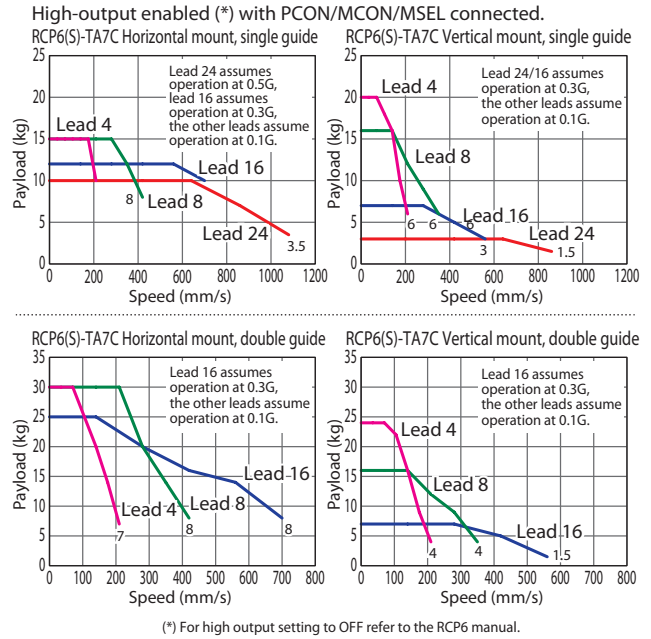

Actuator Specifications (*)

(*) For values of disabled high output controller setting refer to the RCP6 manual.

Lead and Payload

Model Number	Lead (mm)	Connected Controller	Max. Payload		Stroke (mm)
			Horizontal (kg)	Vertical (kg)	
RCP6(S)-TA7C-WA-56P-24-①-②-③-④	24	High-output Enabled	10	3	25~200
RCP6(S)-TA7C-WA-56P-16-①-②-③-④	16	High-output Enabled	12	7	(The increment of stroke is 25mm)
RCP6(S)-TA7C-WA-56P-8-①-②-③-④	8	High-output Enabled	15	16	250/300
RCP6(S)-TA7C-WA-56P-4-①-②-③-④	4	High-output Enabled	15	20	40/65/90~390
RCP6(S)-TA7C-WA-56P-16-①-②-③-④	16	High-output Enabled	25	7	(The increment of stroke is 50mm)
RCP6(S)-TA7C-WA-56P-8-①-②-③-④	8	High-output Enabled	30	16	
RCP6(S)-TA7C-WA-56P-4-①-②-③-④	4	High-output Enabled	30	24	

Legend: ① Stroke ② Applicable controller/I/O type ③ Cable length ④ Options

Stroke and Max. Speed

(Unit: mm/s)

Lead (mm)	Connected Controller	Single Guide		Double Guide	
		25~300	40~290	340	390
24	High-output Enabled	1080 <860>			
16	High-output Enabled	700 <560>	700 <560>	600 <560>	
8	High-output Enabled	420 <350>	420 <350>	365 <350>	300
4	High-output Enabled	210	210	180	150

Values in brackets < > are for vertical use.

Cable Length

Cable Type	Cable Code
Standard	P (1m)
	S (3m)
	M (5m)
Specified Length	X06 (6m) ~ X10 (10m)
	X11 (11m) ~ X15 (15m)
	X16 (16m) ~ X20 (20m)
Robot Cable	R01 (1m) ~ R03 (3m)
	R04 (4m) ~ R05 (5m)
	R06 (6m) ~ R10 (10m)
	R11 (11m) ~ R15 (15m)
	R16 (16m) ~ R20 (20m)

* Refer to P.144 for more information regarding the maintenance cables.

Options

Name	Option Code	Reference Page
Brake	B	See P.105
Cable exit direction (Top)	CJT	See P.105
Cable exit direction (Right)	CJR	See P.105
Cable exit direction (Left)	CJL	See P.105
Cable exit direction (Bottom)	CJB	See P.105
High-rigidity (Double-block guide)	DB	See P.105
Non-motor end specification	NM	See P.110

Actuator Specifications

Item	Description
Drive system	Ball screw ø12mm, rolled C10
Positioning repeatability	±0.01mm
Lost motion	0.1mm or less
Base	Material: Aluminum with white alumite treatment
Static allowable moment	Single guide: Ma: 115N·m, Mb: 115N·m, Mc: 229N·m
	Double guide: Ma: 620N·m, Mb: 620N·m, Mc: 458N·m
Dynamic allowable moment (*)	Single guide: Ma: 44.7N·m, Mb: 44.7N·m, Mc: 89.1N·m
	Double guide: Ma: 196N·m, Mb: 196N·m, Mc: 145N·m
Ambient operating temperature & humidity	0~40°C, 85% RH or less (Non-condensing)

(*) Assumes a standard rated life of 5000km. The service life will vary depending on operation and installation conditions.

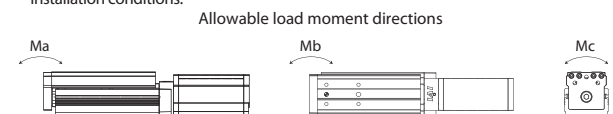

Please refer to the RoboCylinder General Catalog for more information regarding the directions of the allowable moment and overhang load length. Please refer to the RCP6 manual regarding the displacement of the table.

Dimensions

CAD drawings can be downloaded from our website.
www.roboCylinder.de



*1 When the table is returning to its home position, please be careful of interference from surrounding objects, as it will travel until it reaches the M.E.
M.E: Mechanical end S.E: Stroke end

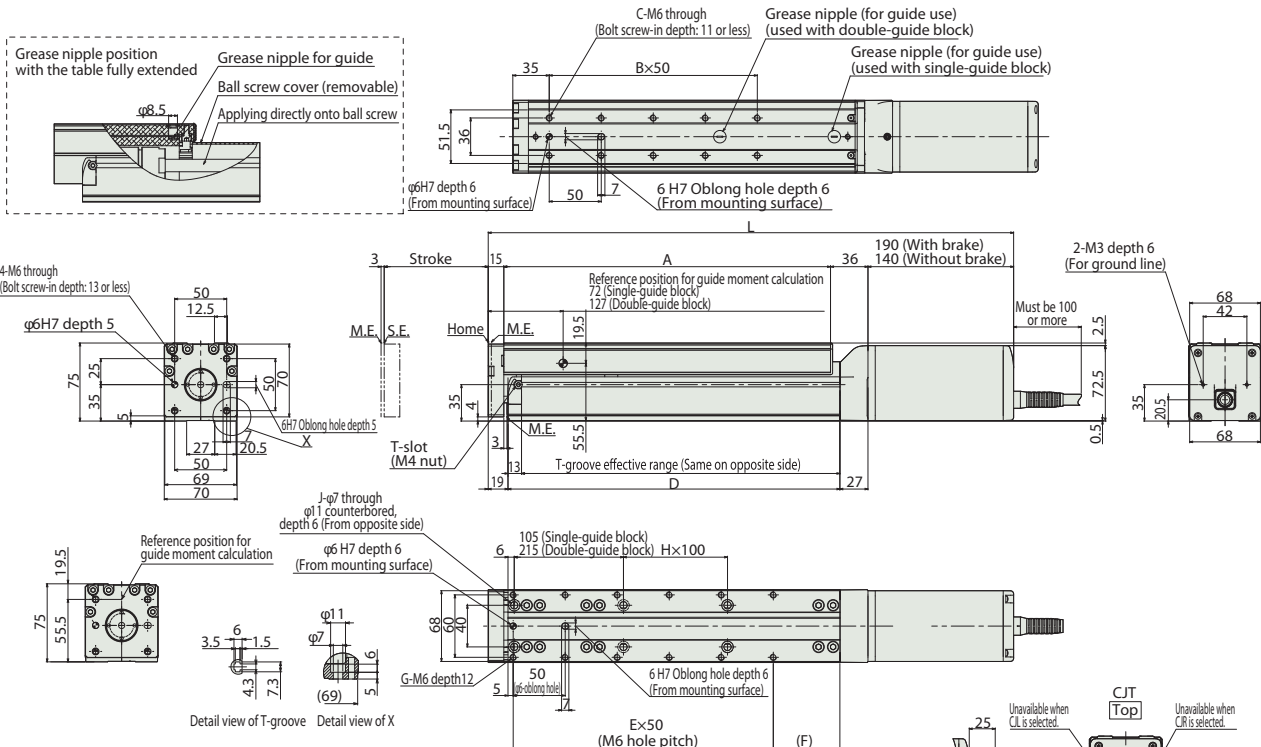

RCP6S-TA7C

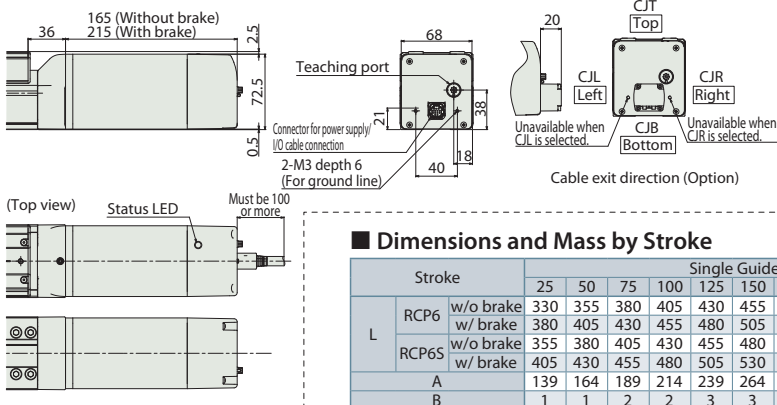

Dimensions and Mass by Stroke

Stroke	Single Guide																Double Guide				
	25	50	75	100	125	150	175	200	250	300	40	65	90	140	190	240	290	340	390		
L	RCP6	w/o brake	330	355	380	405	430	455	480	505	555	605	655	705	755	805	855	905	955		
	w/ brake	380	405	430	455	480	505	530	555	605	655	705	755	805	855	905	955	1005	1055		
L	RCP6S	w/o brake	355	380	405	430	455	480	505	530	580	630	680	730	780	830	880	930	980		
	w/ brake	405	430	455	480	505	530	555	580	630	680	730	780	830	880	930	980	1030	1080		
A		139	164	189	214	239	264	289	314	364	414	464	514	564	614	664	714	764	814		
B		1	1	2	2	3	3	4	4	5	6	7	8	9	10	11	12	13	14		
C		4	4	6	6	8	8	10	10	12	14	16	18	20	22	24	26	28	30		
D		144	169	194	219	244	269	294	319	369	419	469	519	569	619	669	719	769	819		
E		2	2	3	3	4	4	5	5	6	7	8	9	10	11	12	13	14	15		
F		39	64	39	64	39	64	39	64	64	64	64	64	64	64	64	64	64	64		
G		6	6	8	8	10	10	12	12	14	16	18	20	22	24	26	28	30	32		
H		0	0	0	0	1	1	1	1	2	2	0	0	1	1	2	2	3	3		
J		4	4	4	4	6	6	6	6	8	8	4	4	6	6	8	8	10	10		
Mass (kg)	RCP6	w/o brake	3.9	4.1	4.3	4.5	4.7	5.0	5.2	5.4	5.8	6.3	6.8	7.3	7.8	8.3	8.8	9.3	9.8		
	w/ brake	4.3	4.5	4.7	5.0	5.2	5.4	5.6	5.8	6.3	6.7	7.2	7.7	8.2	8.7	9.2	9.7	10.2	10.7		
Mass (kg)	RCP6S	w/o brake	4.0	4.3	4.5	4.7	4.9	5.1	5.3	5.6	6.0	6.4	6.8	7.3	7.7	8.1	8.6	9.1	9.6		
	w/ brake	4.5	4.7	4.9	5.1	5.3	5.6	5.8	6.0	6.4	6.9	7.3	7.7	8.1	8.6	9.1	9.6	10.1	10.6		

Applicable Controllers

The RCP6 series actuators can be operated by the controllers indicated below. Please select the type depending on your intended use. * Please refer to P.147 for more information about the built-in controller of RCP6S series.

Name	External view	Max. number of controlled axes	Input power	Control method				Maximum number of positioning points	Reference page
				Positioner	Pulse train	Program	Network *Option		
PCON-CB/CGB		1	DC24V	●	●	-	DeviceNet CC-Link EtherCAT EtherNet/IP CompoNet	512 (768 for network spec.)	Please see P.132
MCON-C/CG		4		This model is network-compatible only.					
MSEL-PC/PG		4		Single-phase 100~230VAC	-	-	●	30000	Please see the MSEL-PC/PG catalog or manual.

* Please select "high-output specification" as an option for the MCON. With the MCON, operation is possible only when the high-output specification is selected.

RCP6(S)-TA4R

Table Type Motor Unit Coupled Side-mounted Motor Body Width 40* mm 24v Pulse Motor

Model Specification Items

Series	Type	Encoder Type	Motor Type	Lead	Stroke	Applicable Controller/I/O Type	Cable Length	Options
RCP6: Separate Controller RCP6S: Built-in Controller	TA4R	WA: Battery-less Absolute	35P: Pulse Motor 35□ Size	16: 16mm 10: 10mm 5: 5mm 2.5: 2.5mm	25: 25mm 240: 240mm	[RCP6] P3: PCON MCON MSEL [RCP6S] SE: SIO Type	N: None P: 1m S: 3m M: 5m X□□: Specified Length R□□: Robot Cable	Please refer to the options table below. * Please make sure to specify either ML or MR when ordering the side-mounted motor type.

* RCP6 does not include a controller. RCP6S includes a built-in controller.

* Body width does not include the width of the side-mounted motor.

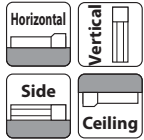

*Depending on the model, there may be some limitations to using the vertical, side, and ceiling mount positions. Please contact IAI for more information regarding mounting positions.



The figure above is the motor side-mounted to the left (ML).

POINT Selection Notes

- The maximum acceleration/deceleration is 1G for horizontal, and 0.5G for vertical use.
- The actuator specification displays the payload's maximum value, but it will vary depending on the acceleration and speed. Please refer to the "Selection Guidelines" (RCP6 Tables of Payload by Speed/Acceleration) on P.115 for more details.
- When performing push-motion operation, please confirm the push force of each model by checking the "Correlation diagram of push force and current limit" on P.113.
- High-rigidity (double-block guide) specification can be selected as an option.

Correlation Diagrams of Speed and Payload

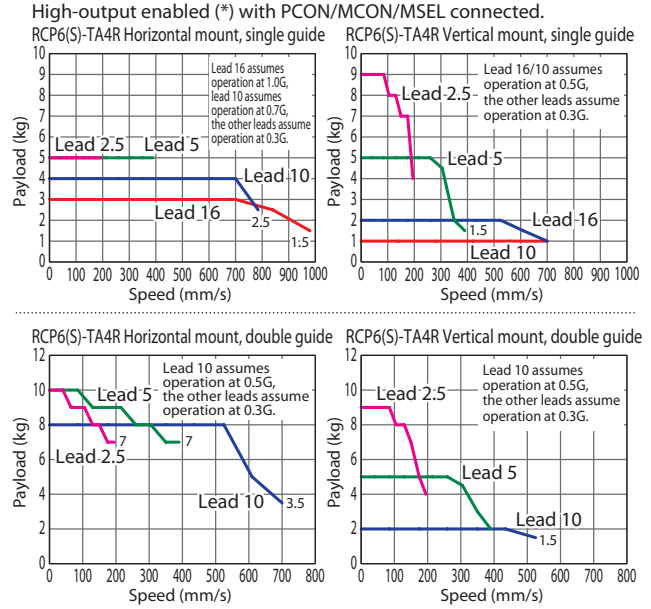

Actuator Specifications (*)

(*) For values of disabled high output controller setting refer to the RCP6 manual.

Lead and Payload

Model Number	Lead (mm)	Connected Controller	Max. Payload		Stroke (mm)
			Horizontal (kg)	Vertical (kg)	
RCP6(S)-TA4R-WA-35P-16-①-②-③-④	16	High-output Enabled	3	1	25~150 (The increment of stroke is 25mm)
RCP6(S)-TA4R-WA-35P-10-①-②-③-④	10	High-output Enabled	4	2.5	
RCP6(S)-TA4R-WA-35P-5-①-②-③-④	5	High-output Enabled	5	5	
RCP6(S)-TA4R-WA-35P-2.5-①-②-③-④	2.5	High-output Enabled	5	10	40/65/90~240 (The increment of stroke is 50mm)
RCP6(S)-TA4R-WA-35P-10-①-②-③-④	10	High-output Enabled	8	2.5	
RCP6(S)-TA4R-WA-35P-5-①-②-③-④	5	High-output Enabled	10	5	
RCP6(S)-TA4R-WA-35P-2.5-①-②-③-④	2.5	High-output Enabled	10	10	

Legend: ① Stroke ② Applicable controller/I/O type ③ Cable length ④ Options

Stroke and Max. Speed

(Unit: mm/s)

Lead (mm)	Connected Controller	Max. Speed	
		Single Guide 25~150	Double Guide 40~190 240
16	High-output Enabled	980 <700>	-
	High-output Disabled	785 <700>	680 <525>
10	High-output Enabled	785 <700>	680 <525>
	High-output Disabled	390	390 340
5	High-output Enabled	390	390 340
	High-output Disabled	195	195 170

Values in brackets < > are for vertical use.

Cable Length

Cable Type	Cable Code
Standard	P (1m)
	S (3m)
	M (5m)
Specified Length	X06 (6m) ~ X10 (10m)
	X11 (11m) ~ X15 (15m)
	X16 (16m) ~ X20 (20m)
Robot Cable	R01 (1m) ~ R03 (3m)
	R04 (4m) ~ R05 (5m)
	R06 (6m) ~ R10 (10m)
	R11 (11m) ~ R15 (15m)
	R16 (16m) ~ R20 (20m)

* Refer to P.144 for more information regarding the maintenance cables.

Options

Name	Option Code	Reference Page
Brake	B	See P.105
Cable exit direction (Outside)	CJO	See P.105
Motor side-mounted to the left	ML	See P.109
Motor side-mounted to the right	MR	See P.109
High-rigidity (Double-block guide)	DB	See P.105
Non-motor end specification	NM	See P.110

Actuator Specifications

Item	Description
Drive system	Ball screw ø8mm, rolled C10
Positioning repeatability	±0.01mm
Lost motion	0.1mm or less
Base	Material: Aluminum with white alumite treatment
Static allowable moment	Single guide: Ma: 13N·m, Mb: 18.6N·m, Mc: 25.3N·m
	Double guide: Ma: 76.8N·m, Mb: 110N·m, Mc: 50.5N·m
Dynamic allowable moment (*)	Single guide: Ma: 4.98N·m, Mb: 7.11N·m, Mc: 9.68N·m
	Double guide: Ma: 23.9N·m, Mb: 34.1N·m, Mc: 15.7N·m
Ambient operating temperature & humidity	0~40°C, 85% RH or less (Non-condensing)

(*) Assumes a standard rated life of 5000km. The service life will vary depending on operation and installation conditions.

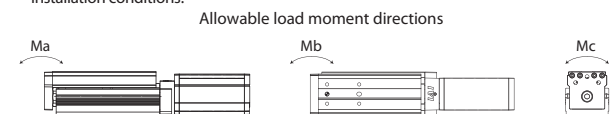

Please refer to the RoboCylinder General Catalog for more information regarding the directions of the allowable moment and overhang load length. Please refer to the RCP6 manual regarding the displacement of the table.

Dimensions

CAD drawings can be downloaded from our website.
www.robocylinder.de

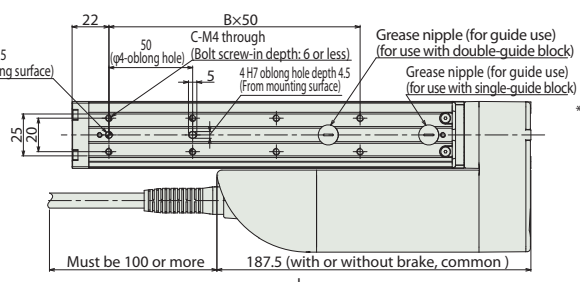
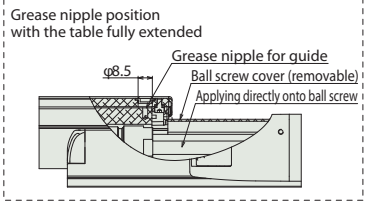

*1 When the table is returning to its home position, please be careful of interference from surrounding objects, as it will travel until it reaches the M.E.
M.E: Mechanical end
S.E: Stroke end

*2 For the single guide type with 25~75mm strokes, tools cannot be used on the φ5 front mounting holes on the top surface because the motor unit interferes. Please use the mounting screw holes on the bottom surface. (Same for the RCP6S)

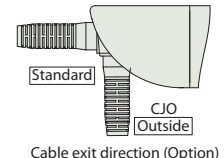
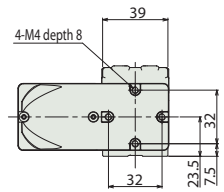
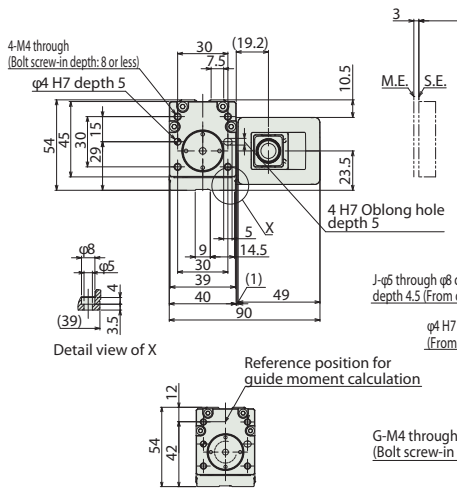

Cable exit direction (Option)

RCP6S-TA4R

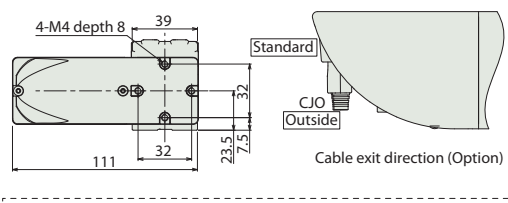
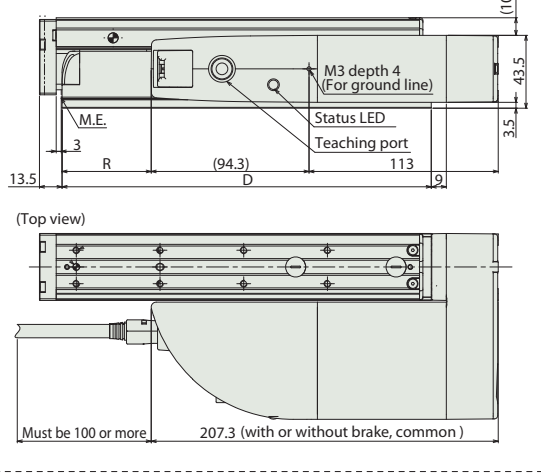

Dimensions and Mass by Stroke

* If the length for R is negative in the table below, the length of the actuator body is shorter than the motor unit.

Stroke	Single Guide										Double Guide				
	25	50	75	100	125	150	40	65	90	140	190	240			
L	149	174	199	224	249	274	224	249	274	324	374	424			
A	92	117	142	167	192	217	167	192	217	267	317	367			
B	1	1	2	2	3	3	2	3	3	4	5	6			
C	4	4	6	6	8	8	6	8	8	10	12	14			
D	95.5	120.5	145.5	170.5	195.5	220.5	170.5	195.5	220.5	270.5	320.5	370.5			
E	1	2	2	3	3	4	3	4	4	5	6	7			
F	35.5	10.5	35.5	10.5	35.5	10.5	10.5	35.5	10.5	10.5	10.5	10.5			
G	4	6	6	8	8	10	8	10	8	10	12	14			
H	0	0	0	0	1	1	0	0	0	1	1	2			
J	4	4	4	4	6	6	4	4	4	6	6	8			
R*	RCP6	-52	-27	-2	23	48	73	23	48	73	123	173			
	RCP6S	-71.8	-46.8	-21.8	3.2	28.2	53.2	3.2	28.2	53.2	103.2	153.2			
Mass (kg)	RCP6	w/o brake	1.3	1.4	1.5	1.6	1.7	1.8	1.7	1.8	1.9	2.1			
		w/ brake	1.4	1.5	1.6	1.7	1.8	1.8	1.9	1.9	2.1	2.3			
	RCP6S	w/o brake	1.5	1.6	1.6	1.7	1.8	1.9	1.8	1.9	2.0	2.2			
		w/ brake	1.5	1.6	1.7	1.8	1.9	2.0	1.9	2.0	2.1	2.2			

Applicable Controllers

The RCP6 series actuators can be operated by the controllers indicated below. Please select the type depending on your intended use. * Please refer to P.147 for more information about the built-in controller of RCP6S series.

Name	External view	Max. number of controlled axes	Input power	Control method				Maximum number of positioning points	Reference page
				Positioner	Pulse train	Program	Network *Option		
PCON-CB/CGB		1	DC24V	● *Option	● *Option	-		512 (768 for network spec.)	Please see P.132
MCON-C/CG		4		This model is network-compatible only.					256
MSEL-PC/PG		4	Single-phase 100~230VAC	-	-	●		30000	Please see the MSEL-PC/PG catalog or manual.

* Please select "high-output specification" as an option for the MCON. With the MCON, operation is possible only when the high-output specification is selected.

RCP6(S)-TA6R

Table Type Motor Unit Coupled Side-mounted Motor Body Width 58* mm 24v Pulse Motor

Model Specification Items	Series	Type	Encoder Type	Motor Type	Lead	Stroke	Applicable Controller/I/O Type	Cable Length	Options
	□	TA6R	WA	42P	□	□	□	□	□
	RCP6: Separate Controller RCP6S: Built-in Controller		WA: Battery-less Absolute	42P: Pulse Motor 42□ Size	20: 20mm 12: 12mm 6: 6mm 3: 3mm	25: 25mm 320: 320mm	[RCP6] P3: PCON MCON MSEL [RCP6S] SE: SIO Type	N : None P : 1m S : 3m M : 5m X□ : Specified Length R□ : Robot Cable	Please refer to the options table below. * Please make sure to specify either ML or MR when ordering the side-mounted motor type.

* RCP6 does not include a controller. RCP6S includes a built-in controller.

* Body width does not include the width of the side-mounted motor.

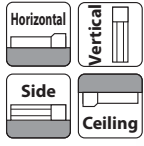

*Depending on the model, there may be some limitations to using the vertical, side, and ceiling mount positions. Please contact IAI for more information regarding mounting positions.



The figure above is the motor side-mounted to the left (ML).

- POINT Selection Notes**
- (1) The maximum acceleration/deceleration is 1G for horizontal, and 0.5G for vertical use.
 - (2) The actuator specification displays the payload's maximum value, but it will vary depending on the acceleration and speed. Please refer to the "Selection Guidelines" (RCP6 Tables of Payload by Speed/Acceleration) on P.115 for more details.
 - (3) When performing push-motion operation, please confirm the push force of each model by checking the "Correlation diagram of push force and current limit" on P.113.
 - (4) Depending on the ambient operational temperature, duty control is necessary for the RCP6S (built-in controller type) with lead 3/6. Please refer to P.130 for more information.
 - (5) High-rigidity (double-block guide) specification can be selected as an option.

Correlation Diagrams of Speed and Payload

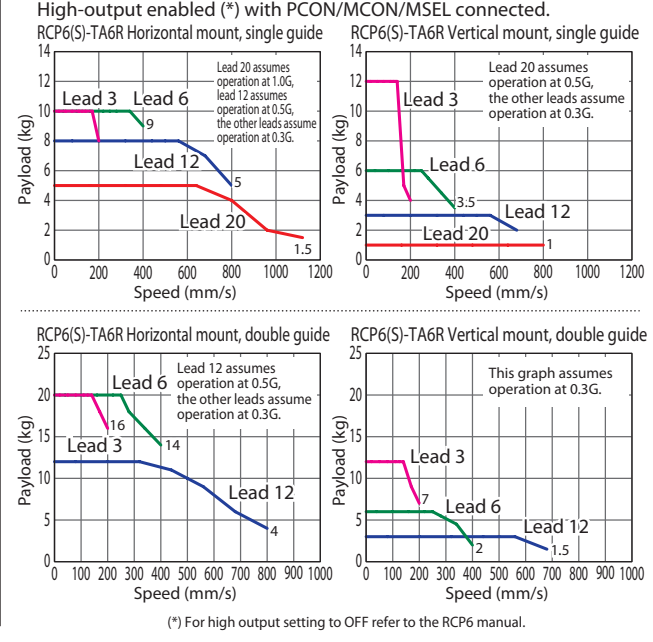

Actuator Specifications (*)

Lead and Payload

Model Number	Lead (mm)	Connected Controller	Max. Payload		Stroke (mm)
			Horizontal (kg)	Vertical (kg)	
RCP6(S)-TA6R-WA-42P-20-①-②-③-④	20	High-output Enabled	5	1	25~200 (The increment of stroke is 25mm)
RCP6(S)-TA6R-WA-42P-12-①-②-③-④	12	High-output Enabled	8	3	
RCP6(S)-TA6R-WA-42P-6-①-②-③-④	6	High-output Enabled	10	6	
RCP6(S)-TA6R-WA-42P-3-①-②-③-④	3	High-output Enabled	10	12	
RCP6(S)-TA6R-WA-42P-12-①-②-③-④	12	High-output Enabled	15	3	40/70/95/ 120~320 (The increment of stroke is 50mm)
RCP6(S)-TA6R-WA-42P-6-①-②-③-④	6	High-output Enabled	20	6	
RCP6(S)-TA6R-WA-42P-3-①-②-③-④	3	High-output Enabled	20	12	

Stroke and Max. Speed

(Unit: mm/s)

Lead (mm)	Connected Controller	Max. Speed			
		Single Guide 25~200	Double Guide		
20	High-output Enabled	1120	270	270	320
		<800>	-	-	-
12	High-output Enabled	800	800	735	575
		<680>	<680>	<680>	<680>
6	High-output Enabled	400	400	365	285
		-	-	-	-
3	High-output Enabled	200	200	185	140
		-	-	-	-

Legend: ① Stroke ② Applicable controller/I/O type ③ Cable length ④ Options

Values in brackets < > are for vertical use.

Cable Length

Cable Type	Cable Code
Standard	P (1m)
	S (3m)
	M (5m)
Specified Length	X06 (6m) ~ X10 (10m)
	X11 (11m) ~ X15 (15m)
	X16 (16m) ~ X20 (20m)
	R01 (1m) ~ R03 (3m)
Robot Cable	R04 (4m) ~ R05 (5m)
	R06 (6m) ~ R10 (10m)
	R11 (11m) ~ R15 (15m)
	R16 (16m) ~ R20 (20m)

* Refer to P.144 for more information regarding the maintenance cables.

Options

Name	Option Code	Reference Page
Brake	B	See P.105
Cable exit direction (Outside)	CJO	See P.105
Motor side-mounted to the left	ML	See P.109
Motor side-mounted to the right	MR	See P.109
High-rigidity (Double-block guide)	DB	See P.105
Non-motor end specification	NM	See P.110

Actuator Specifications

Item	Description
Drive system	Ball screw ø10mm, rolled C10
Positioning repeatability	±0.01mm
Lost motion	0.1mm or less
Base	Material: Aluminum with white alumite treatment
Static allowable moment	Single guide: Ma: 32.3N·m, Mb: 46.2N·m, Mc: 68.3N·m
	Double guide: Ma: 169N·m, Mb: 242N·m, Mc: 137N·m
Dynamic allowable moment (*)	Single guide: Ma: 11.6N·m, Mb: 16.6N·m, Mc: 24.6N·m
	Double guide: Ma: 49.5N·m, Mb: 70.7N·m, Mc: 40N·m
Ambient operating temperature & humidity	0~40°C, 85% RH or less (Non-condensing)

(*) Assumes a standard rated life of 5000km. The service life will vary depending on operation and installation conditions.

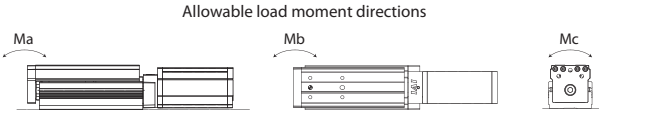

Please refer to the RoboCylinder General Catalog for more information regarding the directions of the allowable moment and overhang load length. Please refer to the RCP6 manual regarding the displacement of the table.

Dimensions

CAD drawings can be downloaded from our website.

www.robocylinder.de



*1 When the table is returning to its home position, please be careful of interference from surrounding objects, as it will travel until it reaches the M.E.
M.E: Mechanical end
S.E: Stroke end

*2 For the single guide type with 25~50mm (RCP6) and 25~125mm (RCP6S) strokes, tools cannot be used on the $\phi 6$ front mounting holes on the top surface because the motor unit interferes. Please use the mounting screw holes on the bottom surface.

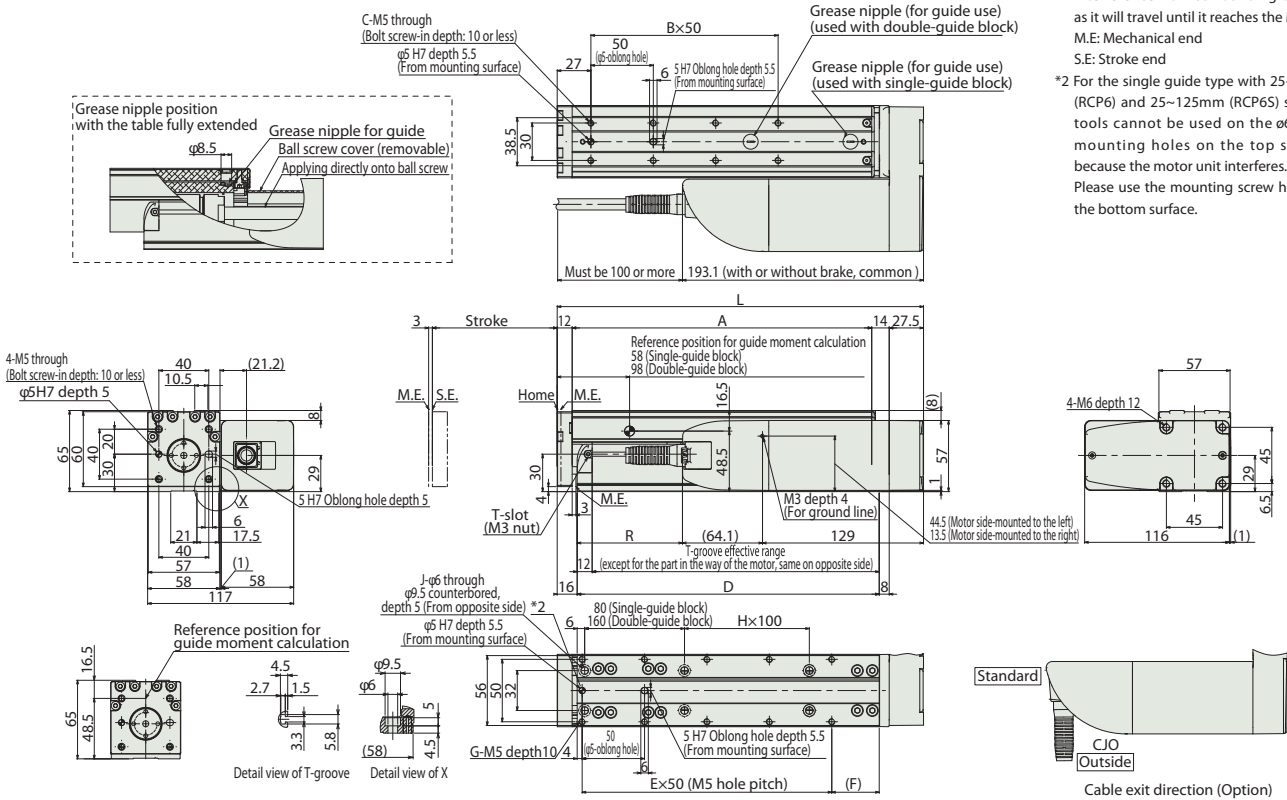

RCP6S-TA6R

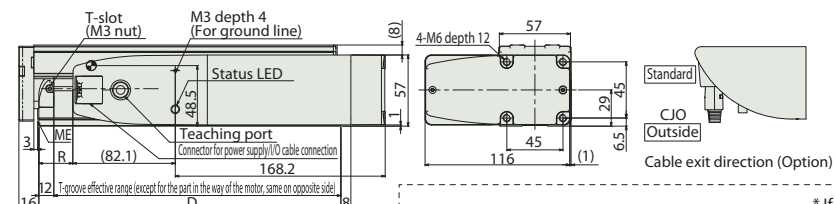

Dimensions and Mass by Stroke

* If the length for R is negative in the table below, the length of the actuator body is shorter than the motor unit.

Stroke	Single Guide										Double Guide									
	25	50	75	100	125	150	175	200	45	70	95	120	170	220	270	320				
L	168.5	193.5	218.5	243.5	268.5	293.5	318.5	343.5	268.5	293.5	318.5	343.5	393.5	443.5	493.5	543.5				
A	115	140	165	190	215	240	265	290	215	240	265	290	340	390	440	490				
B	1	1	2	2	3	3	4	4	3	3	4	4	5	6	7	8				
C	4	4	6	6	8	8	10	10	8	8	10	10	12	14	16	18				
D	117	142	167	192	217	242	267	292	217	242	267	292	342	392	442	492				
E	2	2	3	3	4	4	5	5	4	4	5	5	6	7	8	9				
F	13	38	13	38	13	38	13	38	13	38	13	38	13	38	38	38				
G	6	6	8	8	10	10	12	12	10	10	12	12	14	16	18	20				
H	0	0	0	0	1	1	1	1	0	0	0	0	1	1	2	2				
J	4	4	4	4	6	6	6	6	4	4	4	4	6	6	8	8				
R*	RCP6	-40.6	-15.6	9.4	34.4	59.4	84.4	109.4	134.4	59.4	84.4	109.4	134.4	184.4	234.4	284.4	334.4			
	RCP6S	-97.8	-72.8	-47.8	-22.8	2.2	27.2	52.2	77.2	2.2	27.2	52.2	77.2	127.2	177.2	227.2	277.2			
Mass (kg)	RCP6	2.3	2.5	2.7	2.8	3.0	3.1	3.3	3.5	3.2	3.4	3.5	3.7	4.0	4.3	4.7	5.0			
	w/o brake	2.4	2.6	2.7	2.9	3.0	3.2	3.4	3.5	3.3	3.4	3.6	3.8	4.1	4.4	4.7	5.0			
	w/o brake	2.5	2.6	2.8	3.0	3.1	3.3	3.4	3.6	3.3	3.5	3.7	3.8	4.1	4.5	4.8	5.1			
	RCP6S	2.5	2.7	2.9	3.0	3.2	3.3	3.5	3.7	3.4	3.6	3.7	3.9	4.2	4.5	4.9	5.2			

Applicable Controllers

The RCP6 series actuators can be operated by the controllers indicated below. Please select the type depending on your intended use. * Please refer to P.147 for more information about the built-in controller of RCP6S series.

Name	External view	Max. number of controlled axes	Input power	Control method				Maximum number of positioning points	Reference page
				Positioner	Pulse train	Program	Network *Option		
PCON-CB/CGB		1	DC24V	*Option	*Option	-		512 (768 for network spec.)	Please see P.132
MCON-C/CG		4		This model is network-compatible only.					
MSEL-PC/PG		4	Single-phase 100~230VAC	-	-	•	Note: The type of compatible networks will vary depending on the controller. Please refer to reference page for more information.	30000	Please see the MSEL-PC/PG catalog or manual.

* Please select "high-output specification" as an option for the MCON. With the MCON, operation is possible only when the high-output specification is selected.

RCP6(S)-TA7R

Table Type Motor Unit Coupled Side-mounted Motor Body Width 70* mm 24v Pulse Motor

Model Specification Items	Series	Type	Encoder Type	Motor Type	Lead	Stroke	Applicable Controller / I/O Type	Cable Length	Options
	□	TA7R	WA	56P	□	□	□	□	□
	RCP6: Separate Controller RCP6S: Built-in Controller		WA: Battery-less Absolute	56P: Pulse Motor 56□ Size	24: 24mm 16: 16mm 8: 8mm 4: 4mm	25: 25mm 390: 390mm	[RCP6] P3: PCON MCON MSEL [RCP6S] SE: SIO Type	N : None P : 1m S : 3m M : 5m X□ : Specified Length R□ : Robot Cable	Please refer to the options table below. *Please make sure to specify either ML or MR when ordering the side-mounted motor type.

* RCP6 does not include a controller. RCP6S includes a built-in controller.

* Body width does not include the width of the side-mounted motor.

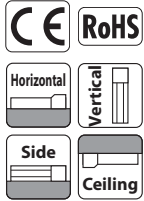

* Depending on the model, there may be some limitations to using the vertical, side, and ceiling mount positions. Please contact IAI for more information regarding mounting positions.



The figure above is the motor side-mounted to the left (ML).



- (1) The maximum acceleration/deceleration is 1G for horizontal, and 0.5G for vertical use.
- (2) The actuator specification displays the payload's maximum value, but it will vary depending on the acceleration and speed. Please refer to the "Selection Guidelines" (RCP6 Tables of Payload by Speed/Acceleration) on P.115 for more details.
- (3) When performing push-motion operation, please confirm the push force of each model by checking the "Correlation diagram of push force and current limit" on P.113.
- (4) Depending on the ambient operational temperature, duty control is necessary for the RCP6S (built-in controller type) with lead 4/8/16. Please refer to P.130 for more information.
- (5) High-rigidity (double-block guide) specification can be selected as an option.

Correlation Diagrams of Speed and Payload

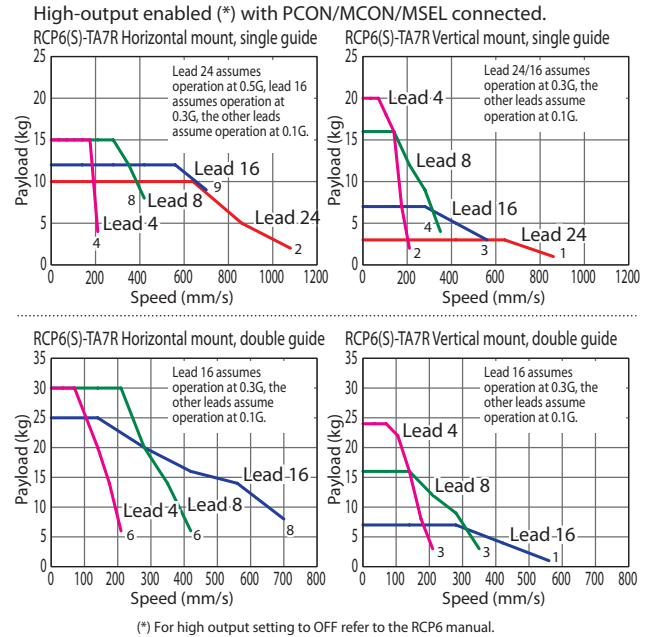

Actuator Specifications (*)

Lead and Payload

Model Number	Lead (mm)	Connected Controller	Max. Payload		Stroke (mm)
			Horizontal (kg)	Vertical (kg)	
RCP6(S)-TA7R-WA-56P-24-①-②-③-④	24	High-output Enabled	10	3	25~200
RCP6(S)-TA7R-WA-56P-16-①-②-③-④	16	High-output Enabled	12	7	(The increment of stroke is 25mm)
RCP6(S)-TA7R-WA-56P-8-①-②-③-④	8	High-output Enabled	15	16	250/300
RCP6(S)-TA7R-WA-56P-4-①-②-③-④	4	High-output Enabled	15	20	
RCP6(S)-TA7R-WA-56P-16-①-②-③-④	16	High-output Enabled	25	7	40/65/90~390
RCP6(S)-TA7R-WA-56P-8-①-②-③-④	8	High-output Enabled	30	16	(The increment of stroke is 50mm)
RCP6(S)-TA7R-WA-56P-4-①-②-③-④	4	High-output Enabled	30	24	

Legend: ① Stroke ② Applicable controller/I/O type ③ Cable length ④ Options

Stroke and Max. Speed

Lead (mm)	Connected Controller	Single Guide			
		25~300	40~290	340	390
24	High-output Enabled	1080 <860>			
16	High-output Enabled	700 <560>	700 <560>	600 <560>	
8	High-output Enabled	420 <350>	420 <350>	365 <350>	300
4	High-output Enabled	210	210	180	150

Values in brackets < > are for vertical use.

Cable Length

Cable Type	Cable Code
Standard	P (1m)
	S (3m)
	M (5m)
Specified Length	X06 (6m) ~ X10 (10m)
	X11 (11m) ~ X15 (15m)
	X16 (16m) ~ X20 (20m)
	R01 (1m) ~ R03 (3m)
Robot Cable	R04 (4m) ~ R05 (5m)
	R06 (6m) ~ R10 (10m)
	R11 (11m) ~ R15 (15m)
	R16 (16m) ~ R20 (20m)

* Refer to P.144 for more information regarding the maintenance cables.

Options

Name	Option Code	Reference Page
Brake	B	See P.105
Cable exit direction (Outside)	CJO	See P.105
Motor side-mounted to the left	ML	See P.109
Motor side-mounted to the right	MR	See P.109
High-rigidity (Double-block guide)	DB	See P.105
Non-motor end specification	NM	See P.110

Actuator Specifications

Item	Description
Drive system	Ball screw ø12mm, rolled C10
Positioning repeatability	±0.01mm
Lost motion	0.1mm or less
Base	Material: Aluminum with white alumite treatment
Static allowable moment	Single guide: Ma: 115N·m, Mb: 115N·m, Mc: 229N·m
	Double guide: Ma: 620N·m, Mb: 620N·m, Mc: 458N·m
Dynamic allowable moment (*)	Single guide: Ma: 44.7N·m, Mb: 44.7N·m, Mc: 89.1N·m
	Double guide: Ma: 196N·m, Mb: 196N·m, Mc: 145N·m
Ambient operating temperature & humidity	0~40°C, 85% RH or less (Non-condensing)

(*) Assumes a standard rated life of 5000km. The service life will vary depending on operation and installation conditions.

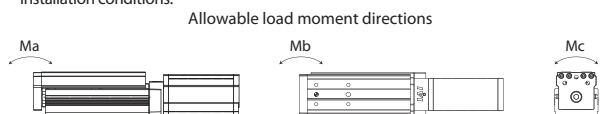

Please refer to the RoboCylinder General Catalog for more information regarding the directions of the allowable moment and overhang load length. Please refer to the RCP6 manual regarding the displacement of the table.

RCP6 Series Options

Brake

Option Code **B** Applicable Models **All Models**

Description This is a holding mechanism that prevents the slider from falling and damaging any attached fittings when the power or servo is turned off.

Cable Exit Direction

Option Code **CJT / CJR / CJL / CJB / CJO** Applicable Models **All Models**

Description This option allows you to change the exit direction of the motor-encoder cable to top, bottom, left, or right.

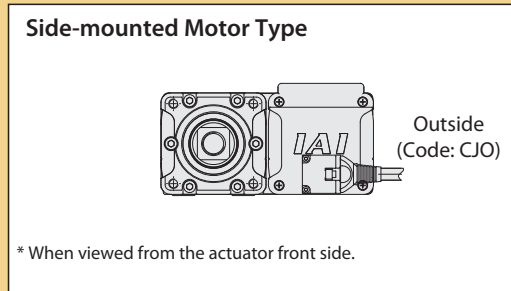
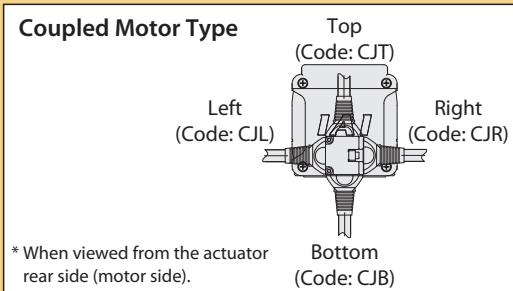

Double-block Guide

Option Code **DB** Applicable Models **RCP6(S)-TA4□/TA6□/TA7□**

Description This option allows the actuator to equip 2 internal guide blocks. The dynamic allowable load moment in the Ma and Mb directions will be increased, and when horizontally mounted, its payload will be doubled.

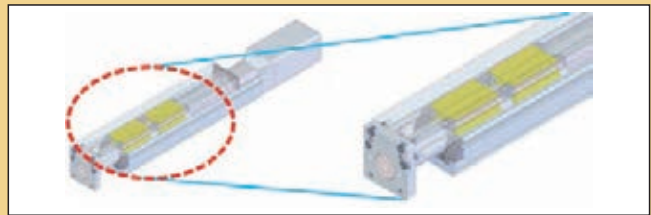

Tip Adapter (Flange)

Option Code **FFA** Applicable Models **RCP6(S)-RRA4□/RRA6□/RA7□**

Description A rod-end tooling adapter with 4 threaded holes.

For RCP6(S)-RRA4□

Model Number: RCP6-FFA-RRA4

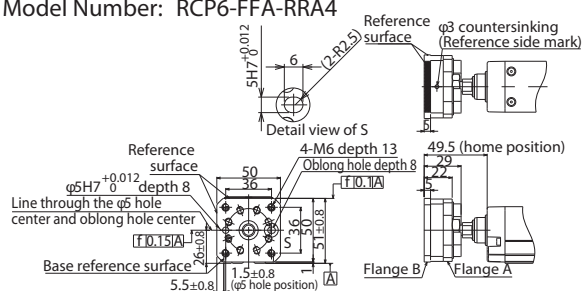

For RCP6(S)-RRA6□

Model Number: RCP6-FFA-RRA6

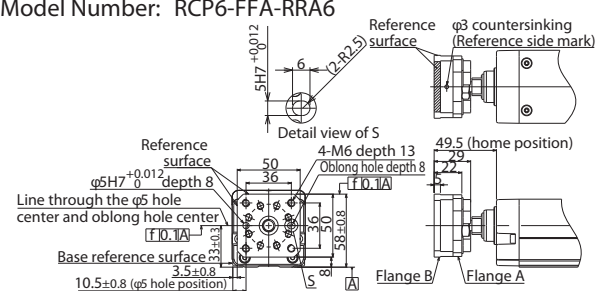

For RCP6(S)-RRA7□

Model Number: RCP6-FFA-RRA7

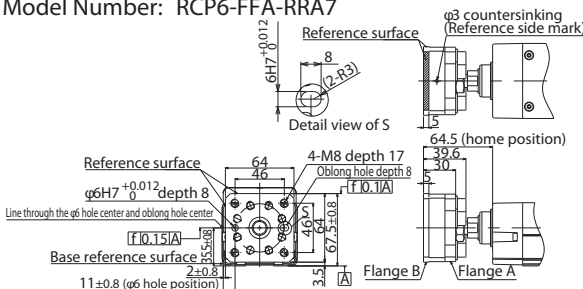

Flange (Front)

Option Code **FL** Applicable Models RCP6(S)-RA4□/RA6□/RA7□/RA8□/RAA4□/RAA6□/RAA7□/RAA8□/WR A10□/WR A12□/WR A14□/WR A16□

Description A bracket that attaches to the actuator body with bolts.

For RCP6(S)-RA4□

Model Number: RCP6-FL-RA4

*Furnished separately. The assembly is to be performed by the customer.

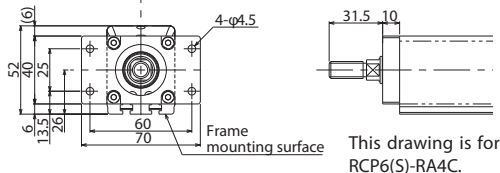

This drawing is for RCP6(S)-RA4C.

For RCP6(S)-RA6□

Model Number: RCP6-FL-RA6

*Furnished separately. The assembly is to be performed by the customer.

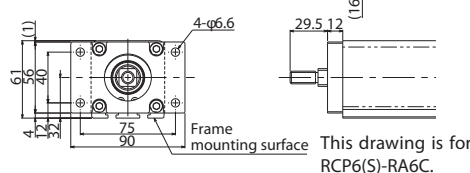

This drawing is for RCP6(S)-RA6C.

For RCP6(S)-RA7□

Model Number: RCP6-FL-RA7

*Furnished separately. The assembly is to be performed by the customer.

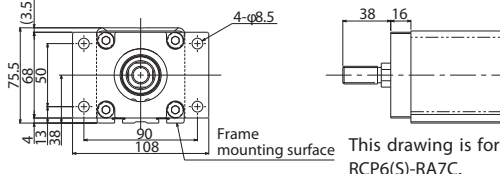

This drawing is for RCP6(S)-RA7C.

For RCP6(S)-RA8□

Model Number: RCP6-FL-RA8

*Furnished separately. The assembly is to be performed by the customer.

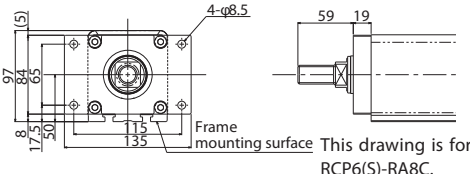

This drawing is for RCP6(S)-RA8C.

For RCP6(S)-RAA4□

Model Number: RCP6-FL-RAA4

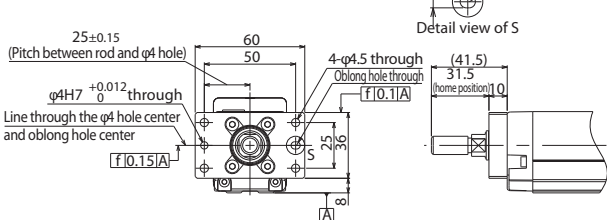

For RCP6(S)-RAA6□

Model Number: RCP6-FL-RAA6

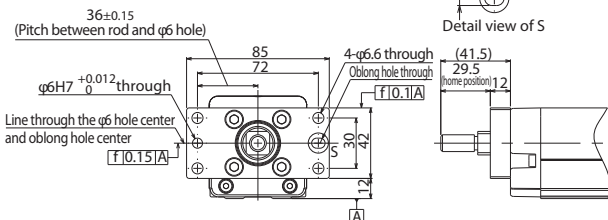

For RCP6(S)-RAA7□

Model Number: RCP6-FL-RAA7

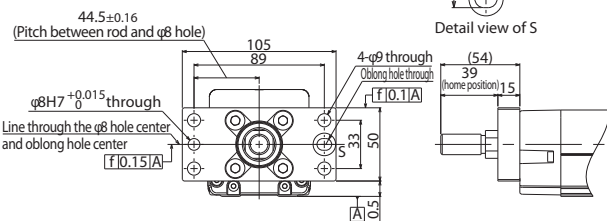

For RCP6(S)-RAA8□

Model Number: RCP6-FL-RAA8

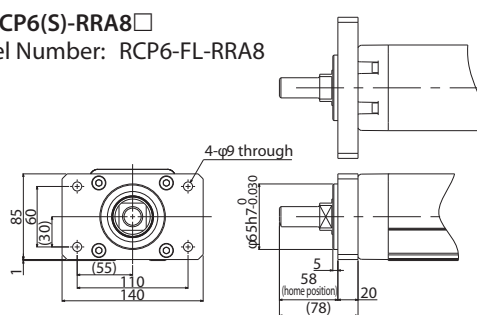

For RCP6(S)-WRA10□

Model Number: RCP6-FL-WRA10

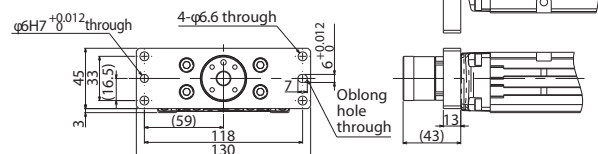

For RCP6(S)-WRA12□

Model Number: RCP6-FL-WRA12

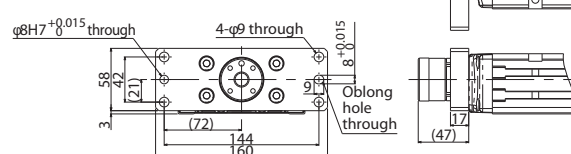

For RCP6(S)-WRA14□
Model Number: RCP6-FL-WRA14

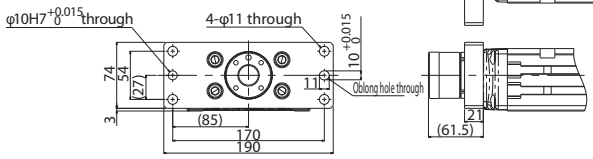

For RCP6(S)-WRA16□
Model Number: RCP6-FL-WRA16

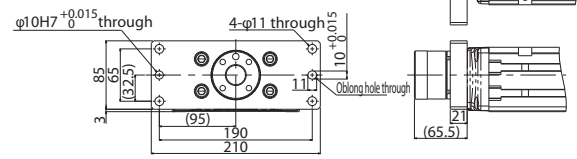

Foot Bracket

Option Code **FT** Applicable Models RCP6(S)-RA4□/RA6□/RA7□/RA8□

Description This is a bracket to fix the actuator with bolts from the top side. (Bolts are tightened from the top, not from the bottom)
For slider type actuators, when the moment load is large, please attach the foot brackets on all the mounting holes on the actuator.
The actuator body may be twisted or deformed if insufficient number of mounting foot brackets are used. Actuator life could also be shortened.
* Refer to the installation dimensions in the actuator drawing for the installation pitch between the foot brackets.

For RCP6(S)-RA4C
Model Number: RCP6-FT-RA4C
(Sold as a set of 2)

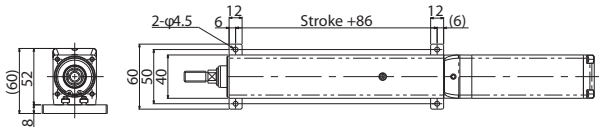

For RCP6(S)-RA6C
Model Number: RCP6-FT-RA6C
(Sold as a set of 2)

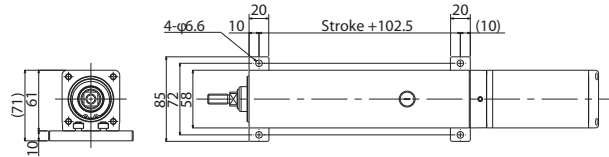

For RCP6(S)-RA7C
Model Number: RCP6-FT-RA7C
(Sold as a set of 2)

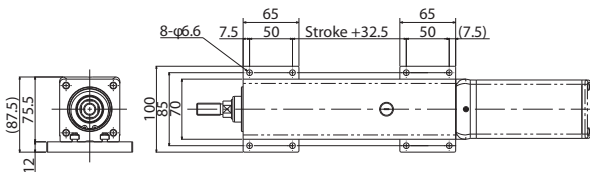

For RCP6(S)-RA8C
Model Number: RCP6-FT-RA8C
(Sold as a set of 2)

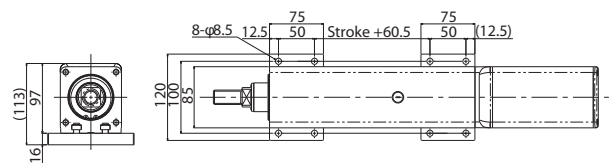

For RCP6(S)-RA4R
Model Number: RCP6-FT-RA4R-1 (For the motor side-mounted to the top)
(Sold as a set of 2)

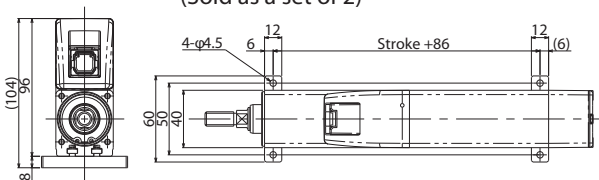

For RCP6(S)-RA6R
Model Number: RCP6-FT-RA6R-1 (For the motor side-mounted to the top)
(Sold as a set of 2)

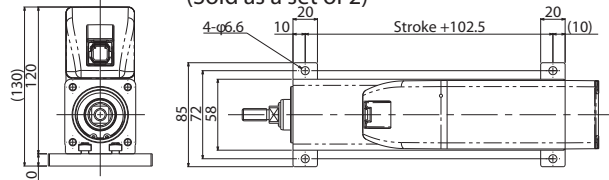

For RCP6(S)-RA7R
Model Number: RCP6-FT-RA7R-1 (For the motor side-mounted to the top)
(Sold as a set of 2)

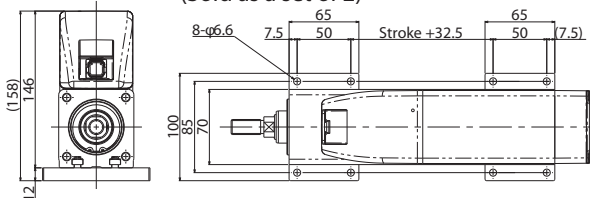

For RCP6(S)-RA8R
Model Number: RCP6-FT-RA8R-1 (For the motor side-mounted to the top)
(Sold as a set of 2)

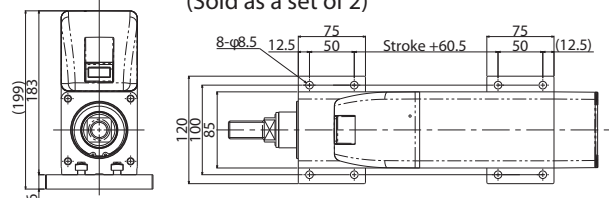

For RCP6-RA4R

Model Number: RCP6-FT-RA4R-2 (For the motor side-mounted to the right/left)
(Sold as a set of 2)

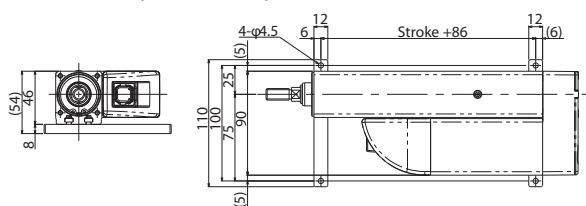

For RCP6S-RA4R

Model Number: RCP6-FT-RA4R-3 (For the motor side-mounted to the right/left)
(Sold as a set of 2)

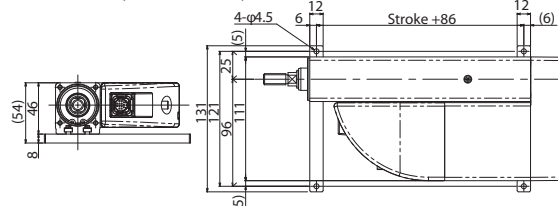

For RCP6(S)-RA6R

Model Number: RCP6-FT-RA6R-2 (For the motor side-mounted to the right/left)
(Sold as a set of 2)

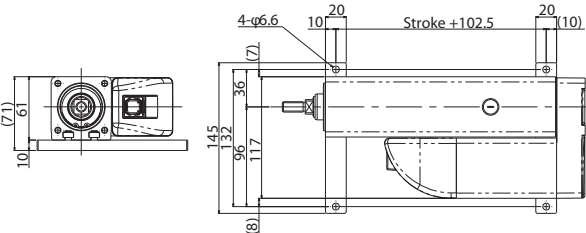

For RCP6(S)-RA7R

Model Number: RCP6-FT-RA7R-2 (For the motor side-mounted to the right/left)
(Sold as a set of 2)

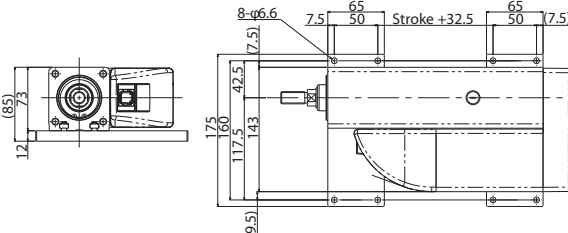

For RCP6(S)-RA8R

Model Number: RCP6-FT-RA8R-2 (For the motor side-mounted to the right/left)
(Sold as a set of 2)

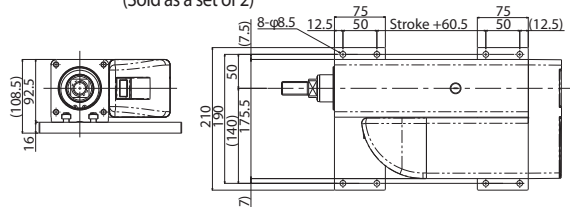

High-precision Specification

Option Code **HPR** Applicable Models RCP6(S)-SA□C/WSA□C

Description The positioning repeatability of the standard type of the RCP6(S) slider and wide slider models is ±0.01mm. If this option is selected, the positioning repeatability can be ±0.005mm. * This option can be selected for actuators with lead 12mm or less.

Tip Adapter (Keyway)

Option Code **KFA** Applicable Models RCP6(S)-RRA4□/RRA6□/RRA7□

Description A female threaded tip adapter with a parallel keyway.

For RCP6(S)-RRA4□

Model Number: RCP6-KFA-RRA4

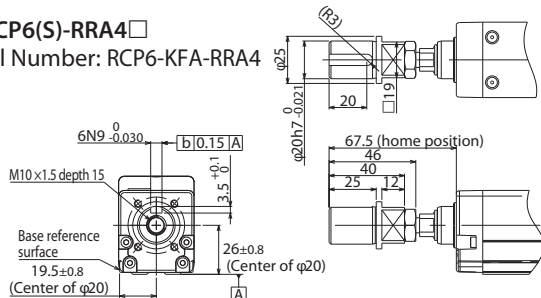

For RCP6(S)-RRA6□

Model Number: RCP6-KFA-RRA6

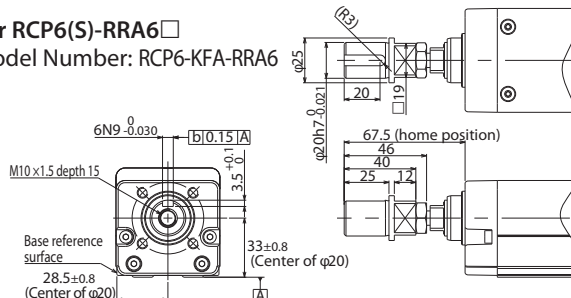

For RCP6(S)-RRA7□

Model Number: RCP6-KFA-RRA7

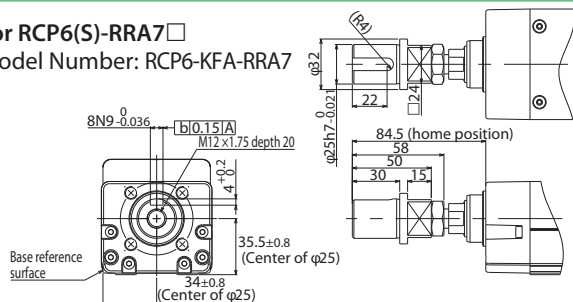

Knuckle Joint

Option Code **NJ** Applicable Models **RCP6(S)-RRA□R**

Description The knuckle joint gives rotational freedom of movement to the rod tip when clevis or trunnion brackets are used.
 * Knuckle joint and clevis brackets for RCP6(S) radial cylinders are furnished separately. The assembly is to be performed by the customer with reference to the mechanical drawings. When making adjustments, we recommend that the parallelism fall within the level mentioned on the mechanical drawings provided. Also, for RCP6(S) Series, please use the knuckle joint and the clevis brackets together as a set.

For RCP6(S)-RRA4R
 Model Number: RCP6-NJ-RRA4R

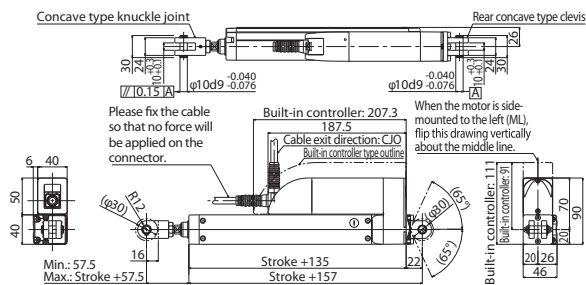

For RCP6(S)-RRA6R
 Model Number: RCP6-NJ-RRA6R

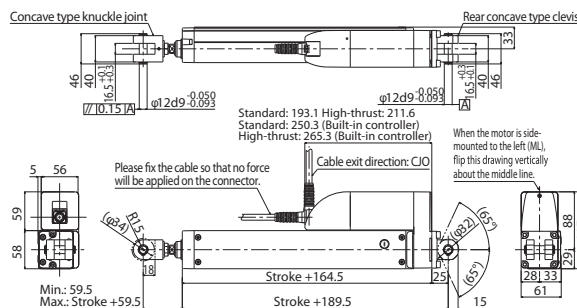

For RCP6(S)-RRA7R
 Model Number: RCP6-NJ-RRA7R

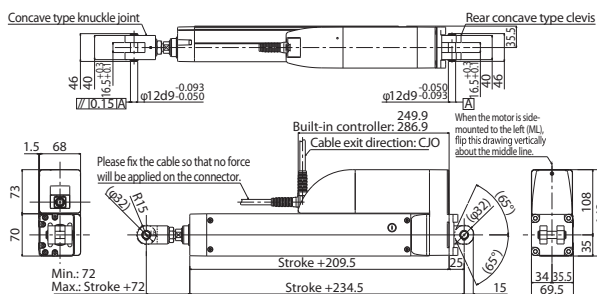

For RCP6(S)-RRA8R
 Model Number: RCP6-NJ-RRA8R

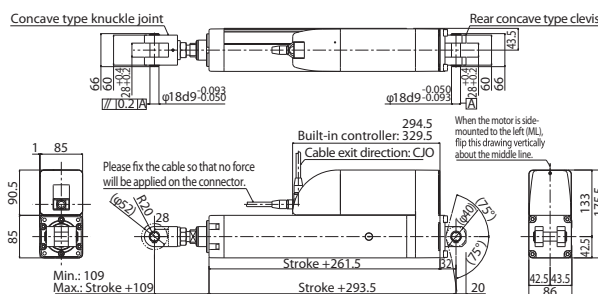

Non-motor End Specification

Option Code **NM** Applicable Models **All Models**

Description The normal home position is set by the slider and rod on the motor side, but there is the option for the home position to be on the other side to accommodate variations in equipment layout, etc. (Please note that changing the home position after the actuators are shipped may require the products to be sent back to IAI for re-setting.)

T-slot Nut Bar

Option Code **NTB / NTBL / NTBR** Applicable Models **RCP6(S)-RA4□/RA6□/RA7□/RA8□/RA10□/RA12□/RA14□/RA16□**

Description T-slot nut bar is a bar-shaped bracket which is to be inserted into the actuator's T-slot. There are fixed holes on the T-slot nut bar. From the motor-side view, NTBL is inserted on the left side, and NTBR is inserted on the right.
 *Rod (RA) type can choose only NTB, while wide radial cylinder (WRA) type can choose either NTBL (for the actuator with its motor side-mounted to the right) or NTBR (for the actuator with its motor side-mounted to the left).

For RCP6(S)-RA4□
 Model Number: RCP6-NTB-RA4

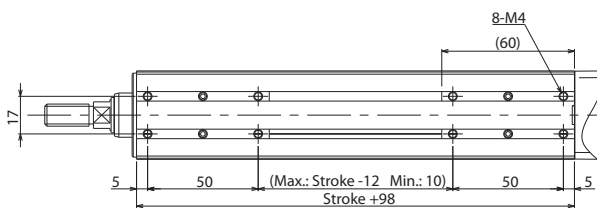

For RCP6(S)-RA6□
 Model Number: RCP6-NTB-RA6

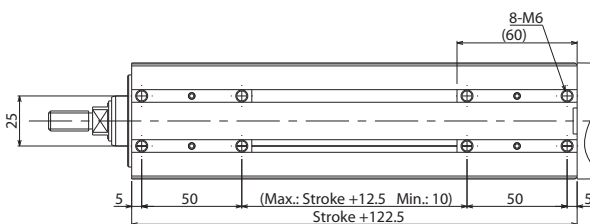

For RCP6(S)-RA7□
Model Number: RCP6-NTB-RA7

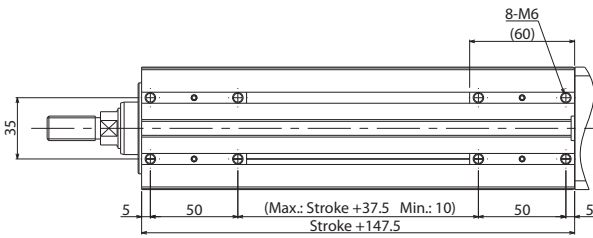

For RCP6(S)-RA8□
Model Number: RCP6-NTB-RA8

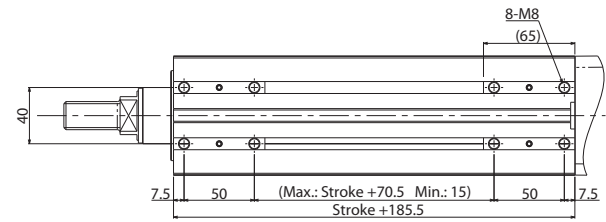

For RCP6(S)-WRA10□
Model Number: RCP6-NTB-WRA10

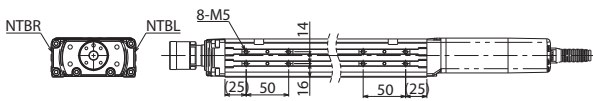

For RCP6(S)-WRA12□
Model Number: RCP6-NTB-WRA12

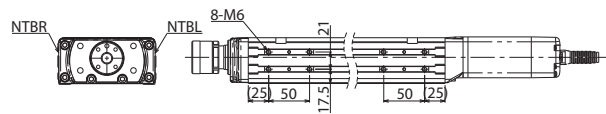

For RCP6(S)-WRA14□
Model Number: RCP6-NTB-WRA14

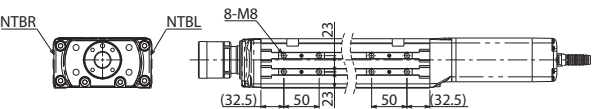

For RCP6(S)-WRA16□
Model Number: RCP6-NTB-WRA16

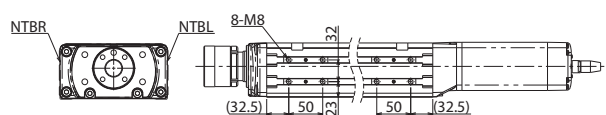

Clevis Bracket

Option Code **QR** Applicable Models **RCP6(S)-RRA□R**

Description A bracket for aligning the cylinder movement when the load installed on the rod tip moves in a direction different from the rod

Applicable Models	Model Number
RCP6(S)-RRA4R	RCP6-QR-RRA4R
RCP6(S)-RRA6R	RCP6-QR-RRA6R
RCP6(S)-RRA7R	RCP6-QR-RRA7R
RCP6(S)-RRA8R	RCP6-QR-RRA8R

* Knuckle joint and clevis brackets for RCP6(S) radial cylinders are furnished separately. The assembly is to be performed by the customer with reference to the mechanical drawings. When making adjustments, we recommend that the parallelism fall within the level mentioned on the mechanical drawings provided. Also, for RCP6(S) Series, please use the knuckle joint and the clevis brackets together as a set. For mechanical drawings, please refer to the knuckle joint option (NJ) on P.110.

Slider Roller Specification

Option Code **SR** Applicable Models **RCP6(S)-SA□/WSA□**

(*) Preview: Cleanroom types RCP6(S)CR-SA□C/WSA□C come later. Please refer to the common RCP6 standard/cleanroom type manual.

Description The slider of the standard slider type specification is changed to the same roller structure of the cleanroom type (*). When using the slider roller spec., the appearance and dimensions of the slider cover will be the same as the cleanroom type.

Slider Spacer

Option Code **SS** Applicable Models **RCP6(S) -SA7R/SA8R**

Description This option changes the top of the slider position to be higher than the motor height.

For RCP6(S)-SA7R
Model Number: RCP6-SS-SA7

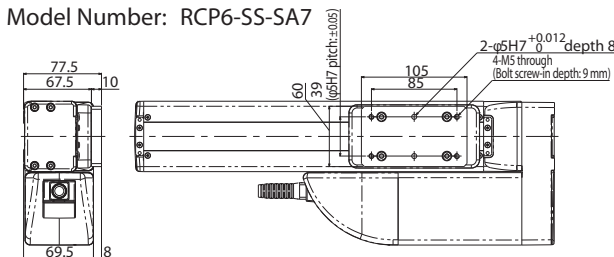

For RCP6(S)-SA8R
Model Number: RCP6-SS-SA8

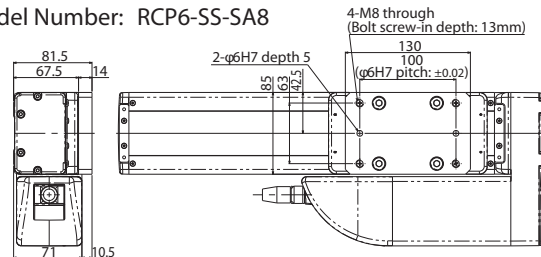

Double SliderOption Code **W**Applicable Models **RCP6(S)-SA□**

Description You can add a free-moving slider which is mounted only to the linear guide (not connected with the ball screw or the belt). The allowance of the dynamic moment and overhang load will be bigger with double slider option.
*Please refer to P.131 for dynamic allowable moment and overhang load length for the double slider.

Selection Notes for RCP6(S) Series**■ Warnings When Selecting the Rod Attachment Option**

- The front flange (FL) rod attachment option cannot be selected when the following strokes are selected for RCP6(S)-RA4R/RA6R/RA7R/RA8R/RRA4R/RRA6R/RRA7R.

• RCP6-RA4R 50mm (Standard/With a brake)	• RCP6S-RA4R 50~100mm (Standard/With a brake)
• RCP6-RA6R 50mm (Standard/With a brake)	• RCP6S-RA6R 50~100mm (Standard/With a brake)
• RCP6-RA7R 50~100mm (Standard/With a brake)	• RCP6S-RA7R 50~150mm (Standard/With a brake)
• RCP6-RA8R 50~100mm (Standard/With a brake)	• RCP6S-RA8R 50~150mm (Standard/With a brake)
• RCP6-RRA4R 60mm (Standard/With a brake)	• RCP6S-RRA4R 60~110mm (Standard/With a brake)
• RCP6-RRA6R 65mm (Standard/With a brake)	• RCP6S-RRA6R 65~115mm (Standard/With a brake)
• RCP6-RRA7R 70mm (Standard/With a brake)	• RCP6S-RRA7R 70~120mm (Standard/With a brake)

- The front flange (FL) rod attachment option cannot be used on side mounting position for RCP6(S)-RRA8R when the following strokes are selected.

• RCP6(S)-RRA8R 50~100mm (Standard/With a brake)

- Please be careful of nearby objects when selecting the front flange (FL) option for the RCP6(S)-RRA□R models, there may be some interference between the cable and installation surface for certain strokes. Please also be careful of nearby objects when selecting the tip adapter option (FFA, NFA, KFA) for the RCP6(S)-RRA4R/RRA6R/RRA7R models, there may be some interference between the cable and work piece for certain strokes.

■ Warnings When Installing the Rod Actuators

When installing the front bracket or flange (optional), please be careful that the actuator does not experience any external force. (External force may cause malfunctions or damaged parts)

If the actuator will experience external force or is being used in conjunction with a Cartesian robot, etc., please use the mounting holes on the base of the actuator to secure it into place. Even in cases when external force will not be applied, to secure the actuator in place when installed horizontally using a flange or side-mounted motor specification, please use the bracket mounting holes to create a support base as shown in the diagram on the right.

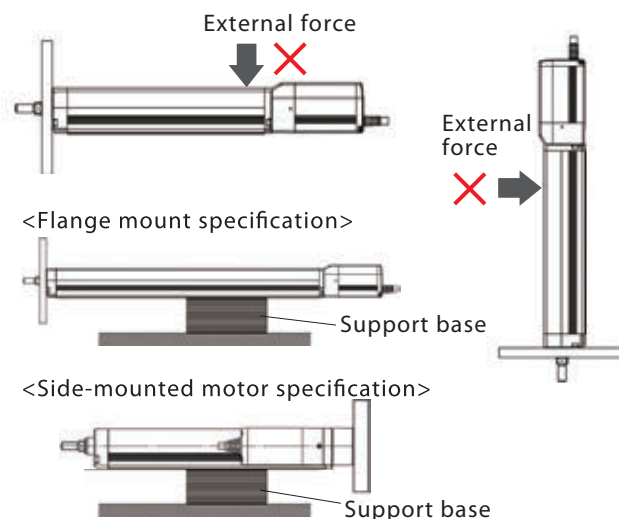
**■ About the Mounting Positions**

- While installation in the side and ceiling mount positions are available, this may cause slack or misalignment in the stainless steel sheet. Continuing to use it this way could cause the stainless steel sheet to break. Please inspect it daily and adjust the sheet if any slack or misalignment is found.
- When installing the motor-coupled type vertically, please set the motor on the top if possible. While installing the motor on the bottom will not cause problems in normal operation, long periods of no activity may cause the grease to separate, flow into the motor unit, and cause problems in rare occasions.

Correlation Diagrams of Push Force and Current Limit

RCP6 Series **Slider Type/Rod Type**

In the push-motion operation, the push force can be changed by changing the current force of the controller to be between 20% (30%) - 70%. The maximum push force will vary depending on the model, so please refer to the graphs below and on the following page, and select one based on the needed push force for your intended use.

When performing the push-motion operation with the slider type, please limit the push current in order that the reactive moment caused by the push force does not exceed the dynamic allowable moment (Ma, Mb) specified in the catalog (It should be 80% or less of the dynamic allowable moment for the slider type). Please refer to the figures below, which show the working point of the guide moment, for help with calculating the moment. This can be done by considering the offset of the push force application position. Please note that if excessive force which exceeds the dynamic allowable moment is applied, it may damage the guide and shorten its service life. Please keep this in mind and select a push current that is safely within its limits.

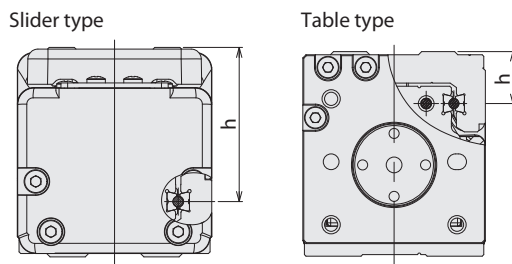

Working point of the guide moment

h dimension			
Slider type		Table type	
SA4	36	TA4	12
SA6	46	TA6	16.5
SA7	48	TA7	19.5
SA8	45.5		
WSA10	26.5		
WSA12	32		
WSA14	36		
WSA16	38.5		

* Unit: mm

Calculation example)

If push-motion operation is performed with an RCP6-SA7C by applying 200N at the position shown to the right, the moment received by the guide, or Ma, is calculated as:

$$Ma = (48 + 50) \times 200 = 19600 \text{ (N}\cdot\text{mm)}$$

$$= 19.6 \text{ (N}\cdot\text{m)}$$

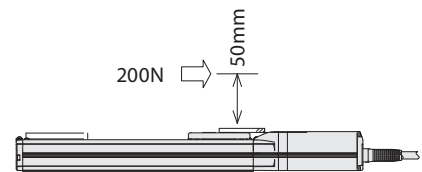

Since the dynamic allowable moment of the SA7C is $Ma = 44.7 \text{ (N}\cdot\text{m)}$, so $44.7 \times 0.8 = 35.76 > 19.6$, this is an acceptable selection. Also, should an Mb moment occur due to the push operation, calculate the moment from the overhang and ensure that it is within range of the dynamic allowable moment.

Correlation Diagrams of Push Force and Current Limit * The graphs below are only a reference, and the graphs may vary slightly from the actual.

SA4/RA4/RRA4/TA4 Type

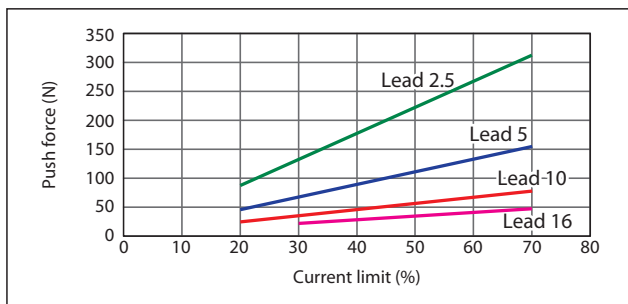

SA6/RA6/RRA6/TA6 Type

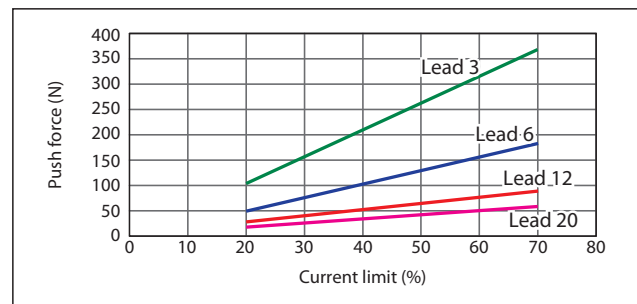

SA7/TA7/WSA14 Type

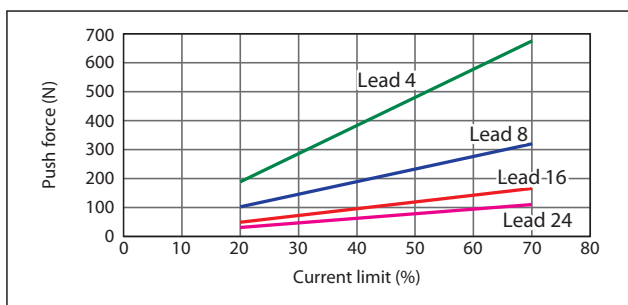

SA8/WSA16 Type

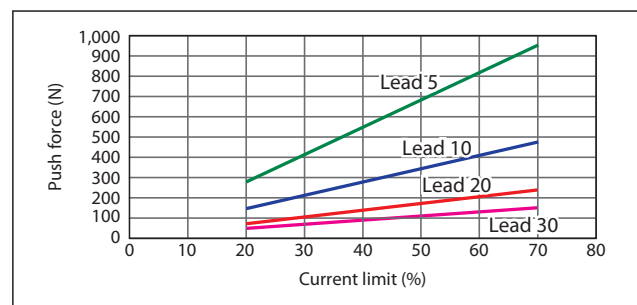

WSA10/WRA10 Type

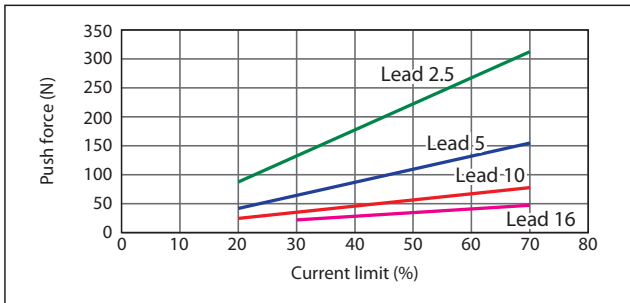

WSA12/WRA12 Type

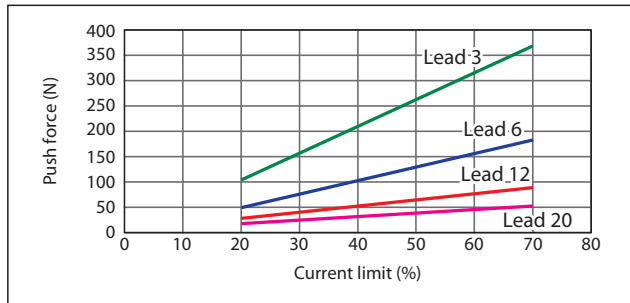

RA7/RRA7/WRA14 Type

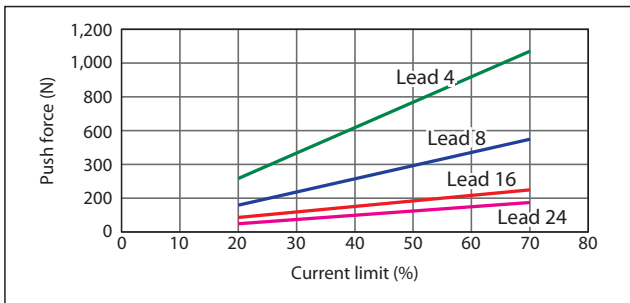

RA8/RRA8/WRA16 Type

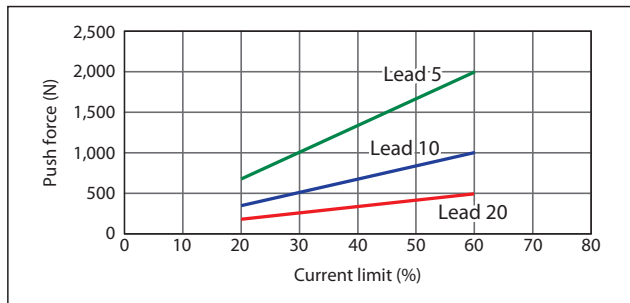

Vertical Payload and Service Life

* The graph below is only a reference, and the graph may vary slightly from the actual.

When using RCP6(S)-RA8, RRA8, WSA16 (lead 5 only), WRA16 (lead 5 only) vertically, their service life will vary greatly depending on the payload. Please check the following graph.

RA8/RRA8/WSA16/WRA16 Type

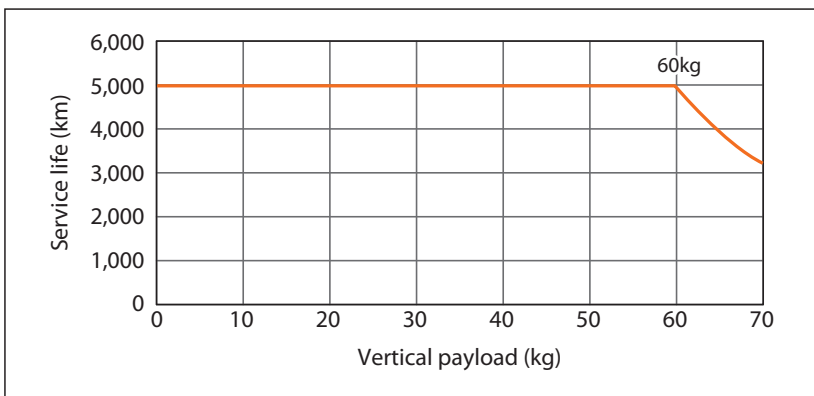

Tables of Payload by Speed/Acceleration

The tables below shows the maximum payload in each acceleration/deceleration for different models. Please select a model that satisfies the operational conditions you desire.
For the MCON controller, high-output enabled operation is only available if "high-output setting" is selected as an option.

RCP6 Series SA□C: Slider Type, Motor Coupled Specification

High-output Setting Enabled

Please refer to the RCP6 manual regarding dedicated tables of RCP6(S)-SA4C/SA6C/SA7C with disabled high-output setting.

■ RCP6/RCP6S-SA4C

Lead 16

Orientation	Horizontal					Vertical				
	Acceleration (G)									
Speed (mm/s)	0.1	0.3	0.5	0.7	1	0.1	0.3	0.5	0.7	1
0	7	7	5	5	4.5	1.5	1.5	1.5	1.5	1.5
140	7	7	5	5	4.5	1.5	1.5	1.5	1.5	1.5
280	7	7	5	5	4.5	1.5	1.5	1.5	1.5	1.5
420	7	7	5	5	4.5	1.5	1.5	1.5	1.5	1.5
560	7	7	5	5	4.5	1.5	1.5	1.5	1.5	1.5
700	6	6	5	4.5	4	1.5	1.5	1.5	1.5	1.5
840	6	4	4	3.5		1	1			
980	4	4	3	2.5		1	1			
1120			2.5	2	1.5		1	0.75		
1260			2	1.5	1			0.5		

Lead 10

Orientation	Horizontal					Vertical				
	Acceleration (G)									
Speed (mm/s)	0.1	0.3	0.5	0.7	1	0.1	0.3	0.5	0.7	1
0	12	12	12	10	9	3	3	3	3	3
85	12	12	12	10	9	3	3	3	3	3
175	12	12	12	10	9	3	3	3	3	3
260	12	12	12	10	9	3	3	3	3	3
350	12	12	12	10	9	3	3	3	3	3
435	12	12	12	10	8	2.5	2.5	2.5	2.5	2.5
525	12	12	10	8	7	2.25	2.25	2.25	2.25	2.25
610	12	10	8	6	5	2.25	2.25	2.25		
700		8	6	4	3	2	1.75			
785		7	4	3	3	1.5	1.25			

Lead 5

Orientation	Horizontal					Vertical				
	Acceleration (G)									
Speed (mm/s)	0.1	0.3	0.5	0.7	1	0.1	0.3	0.5	0.7	1
0	14	14	14	14	14	5.5	5.5	5.5	5.5	5.5
40	14	14	14	14	14	5.5	5.5	5.5	5.5	5.5
85	14	14	14	14	14	5.5	5.5	5.5	5.5	5.5
130	14	14	14	14	14	5.5	5.5	5.5	5.5	5.5
175	14	14	14	14	14	5.5	5.5	5.5	5.5	5.5
215	14	14	14	14	14	5.5	5.5	5.5	5.5	5.5
260	14	14	14	14	13	5.5	5.5	5.5	5.5	5.5
305	14	14	14	14	12	5	5	5		
350	14	12	12	12	10	4.5	4.5	4.5		
390	14	10	10	10	10	4	4	3.5		

Lead 2.5

Orientation	Horizontal					Vertical				
	Acceleration (G)									
Speed (mm/s)	0.1	0.3	0.5	0.7	1	0.1	0.3	0.5	0.7	1
0	18	18	18	18	18	12	12	12	12	12
20	18	18	18	18	18	12	12	12	12	12
40	18	18	18	18	18	12	12	12	12	12
65	18	18	18	18	18	12	12	12	12	12
85	18	18	18	18	18	12	12	12	12	12
105	18	18	18	18	18	12	12	12	12	12
130	18	18	18	18	18	11	11	11	11	11
150	18	18	18	18	18	10	10	10	10	10
175	18	18	18	18	18	9	9	9	9	9
195	18	18	18	18	18	8	8	8	8	8

■ RCP6/RCP6S-SA6C

Lead 20

Orientation	Horizontal					Vertical				
	Acceleration (G)									
Speed (mm/s)	0.1	0.3	0.5	0.7	1	0.1	0.3	0.5	0.7	1
0	15	15	10	8	7	1	1	1	1	1
160	15	15	10	8	7	1	1	1	1	1
320	15	12	10	8	6	1	1	1	1	1
480	12	12	9	8	6	1	1	1	1	1
640	12	12	8	6	5	1	1	1	1	1
800	10	10	6.5	4.5	3	1	1	1	1	1
960		8	5	3.5	2		1	1		
1120		6.5	3	2	1.5		0.5	0.5		
1280			1	1	1			0.5		
1440			1	0.5						

Lead 12

Orientation	Horizontal					Vertical				
	Acceleration (G)									
Speed (mm/s)	0.1	0.3	0.5	0.7	1	0.1	0.3	0.5	0.7	1
0	28	26	18	16	14	2.5	2.5	2.5	2.5	2.5
80	28	26	18	16	14	2.5	2.5	2.5	2.5	2.5
200	28	26	18	16	14	2.5	2.5	2.5	2.5	2.5
320	28	26	18	14	12	2.5	2.5	2.5	2.5	2.5
440	28	26	18	12	10	2.5	2.5	2.5	2.5	2.5
560	28	20	12	8	7	2.5	2.5	2.5	2.5	2.5
680	20	15	9	5	4	2.5	2.5	2.5	2.5	2.5
800	15	9	5	2	1	2	2	1		
900		5	3	1	1		0.5	0.5		

Lead 6

Orientation	Horizontal					Vertical				
	Acceleration (G)									
Speed (mm/s)	0.1	0.3	0.5	0.7	1	0.1	0.3	0.5	0.7	1
0	32	32	26	24	20	6	6	6	6	6
40	32	32	26	24	20	6	6	6	6	6
100	32	32	26	24	20	6	6	6	6	6
160	32	32	26	24	20	6	6	6	6	6
220	32	32	26	24	20	6	6	6	6	6
280	32	32	26	24	15	6	6	5.5		
340	32	32	20	18	12	6	5	4.5		
400	32	22	12	11	8	4.5	3.5	3.5		
450	26	15	8	6	4	3.5	2	2		

Lead 3

Orientation	Horizontal					Vertical				
	Acceleration (G)									
Speed (mm/s)	0.1	0.3	0.5	0.7	1	0.1	0.3	0.5	0.7	1
0	40	40	35	35	35	16	16	16	16	16
20	40	40	35	35	35	16	16	16	16	16
50	40	40	35	35	35	16	16	16	16	16
80	40	40	35	35	30	16	16	16	16	16
110	40	40	35	35	30	16	16	16	16	16
140	40	40	35	35	28	16	15	15	15	15
170	40	40	32	32	24	14	13	12		
200	40	35	28	25	20	11	10	9		
225	40	28	20	18	14	9	8			

■ RCP6/RCP6S-SA7C

Lead 24

Orientation	Horizontal					Vertical				
	Acceleration (G)									
Speed (mm/s)	0.1	0.3	0.5	0.7	1	0.1	0.3	0.5	0.7	1
0	37	37	22	16	14	3	3	3	3	3
200	37	37	22	16	14	3	3	3	3	3
420	37	34	20	16	14	3	3	3	3	3
640	37	20	15	10	9	3	3	3	3	3
860		12	10	7	4		3	2.5		
1080		8	4.5	4	2		2	1		
1200			5.5	2	2		1	1		

Lead 16

Orientation	Horizontal					Vertical				
	Acceleration (G)									
Speed (mm/s)	0.1	0.3	0.5	0.7	1	0.1	0.3	0.5	0.7	1
0	46	46	35	28	27	8	8	8	8	8
140	46	46	35	28	27	8	8	8	8	8
280	46	46	35	25	24	8	8	8	8	8
420	46	34	25	15	10	6	5	4.5		
560	35	20	15	10	6	5	4	3		
700	20	15	10	5	3	4	3	2		
840		9	4	2			1			
980		4								

Lead 8

Orientation	Horizontal					Vertical				
	Acceleration (G)									
Speed (mm/s)	0.1	0.3	0.5	0.7	1	0.1	0.3	0.5	0.7	1
0	51	51	45	40	40	16	16	16	16	16
70	51	51	45	40	40	16	16	16	16	16
140	51	51	40	38	35	16	16	16	16	16
210	51	51	35	30	24	11	10	9.5		
280	51	40	28	20	15	9	8	7		
350	51	30	9	4		7	5	4		
420	40	7				5	2			
490	20					2				

Lead 4

Orientation	Horizontal					Vertical				
	Acceleration (G)									
Speed (mm/s)	0.1	0.3	0.5	0.7	1	0.1	0.3	0.5	0.7	1
0	55	51	45	40	40	25	25	25	25	25
35	55	51	45	40	40	25	25	25	25	25
70	55	51	45	40	40	25	25	25	25	25
105	55	51	45	40	35	22	20	19		
140	55	45	35	30	25	16	14	12		
175	55	30	18			11	9	7.5		
210	45	8				8				
245	35									

RCP6 Series

SA□R: Slider Type, Side-mounted Motor Specification

High-output Setting Enabled

Please refer to the RCP6 manual regarding dedicated tables of RCP6(S)-SA4R/SA6R/SA7R with disabled high-output setting.

■ RCP6/RCP6S-SA4R

Lead 16

Orientation	Horizontal					Vertical				
	Acceleration (G)									
Speed (mm/s)	0.1	0.3	0.5	0.7	1	0.1	0.3	0.5		
0	7	7	5	4.5	4.5	1.5	1.5	1.5		
140	7	7	5	4.5	4.5	1.5	1.5	1.5		
280	7	7	5	4.5	4.5	1.5	1.5	1.5		
420	7	7	5	4.5	4.5	1.5	1.5	1.5		
560	7	7	5	4.5	4	1.5	1.5	1.5		
700	6	5	4	4		1	1	1		
840	6	4	3	3		1	1	1		
980	4	4	2.5	2		1	1	1		
1120		2.5	1	1				0.5		
1260			1	0.5	0.5					

Lead 10

Orientation	Horizontal					Vertical				
	Acceleration (G)									
Speed (mm/s)	0.1	0.3	0.5	0.7	1	0.1	0.3	0.5		
0	12	12	12	10	9	3	3	3		
85	12	12	12	10	9	3	3	3		
175	12	12	12	10	9	3	3	3		
260	12	12	10	9	9	3	3	3		
350	12	12	10	9	8	3	3	3		
435	12	12	10	9	8	2.5	2.5	2.5		
525	12	12	9	7	7	2.25	2.25	2.25		
610		10	7	5	4	2.25	2	2		
700		7	4	3	2		1.5	1		
785		4	3	2	1.5		1	1		

Lead 5

Orientation	Horizontal					Vertical				
	Acceleration (G)									
Speed (mm/s)	0.1	0.3	0.5	0.7	1	0.1	0.3	0.5		
0	14	14	14	12	12	5.5	5.5	5.5		
40	14	14	14	12	12	5.5	5.5	5.5		
85	14	14	14	12	12	5.5	5.5	5.5		
130	14	14	12	12	11	5.5	5.5	5.5		
175	14	14	12	12	11	5.5	5.5	5.5		
215	14	14	12	12	11	5.5	5.5	5.5		
260	14	14	12	12	11	5.5	5.5	5		
305	14	14	12	12	11	5	5	4.5		
350	14	12	12	10	10	4	4	4		
390	14	10	7	6	4	3.5	3.5	2.5		

Lead 2.5

Orientation	Horizontal					Vertical				
	Acceleration (G)									
Speed (mm/s)	0.1	0.3	0.5	0.7	1	0.1	0.3	0.5		
0	18	18	18	18	18	12	12	12		
20	18	18	18	18	18	12	12	12		
40	18	18	18	18	18	12	12	12		
65	18	18	16	16	16	12	12	12		
85	18	18	16	16	16	12	12	12		
105	18	18	16	15	15	12	12	12		
130	18	18	16	15	14	11	11	11		
150	18	18	16	15	14	10	10	10		
175	18	18	16	15	14	8	7	7		
195	18	18	16	14	10	7	5	5		

■ RCP6/RCP6S-SA6R

Lead 20

Orientation	Horizontal					Vertical				
	Acceleration (G)									
Speed (mm/s)	0.1	0.3	0.5	0.7	1	0.1	0.3	0.5		
0	15	15	10	8	7	1	1	1		
160	15	15	10	8	7	1	1	1		
320	15	12	10	8	6	1	1	1		
480	12	12	9	8	6	1	1	1		
640	12	12	8	6	5	1	1	1		
800	10	10	6.5	4.5	3	1	1	1		
960		8	5	3.5	2		1	1		
1120		6	3	2	1.5			0.5		
1280			1	0.5	0.5					

Lead 12

Orientation	Horizontal					Vertical				
	Acceleration (G)									
Speed (mm/s)	0.1	0.3	0.5	0.7	1	0.1	0.3	0.5		
0	28	26	18	16	14	2.5	2.5	2.5		
80	28	26	18	16	14	2.5	2.5	2.5		
200	28	26	18	16	14	2.5	2.5	2.5		
320	28	26	18	14	12	2.5	2.5	2.5		
440	28	26	18	12	10	2.5	2.5	2.5		
560	28	20	12	8	7	2.5	2.5	2.5		
680	20	15	9	5	3	2.5	2.5	2.5		
800	15	9	5	2	1	2	1.5	1		
900		5	3	1						

Lead 6

Orientation	Horizontal					Vertical				
	Acceleration (G)									
Speed (mm/s)	0.1	0.3	0.5	0.7	1	0.1	0.3	0.5		
0	32	32	26	24	20	6	6	6		
40	32	32	26	24	20	6	6	6		
100	32	32	26	24	20	6	6	6		
160	32	32	26	24	20	6	6	6		
220	32	32	26	24	20	6	6	6		
280	32	32	26	24	15	6	6	5.5		
340	32	32	20	18	12	6	5	4.5		
400	32	20	12	11	8	4.5	3.5	3.5		
450	26	12	6	5	3	3	2	2		

Lead 3

Orientation	Horizontal					Vertical				
	Acceleration (G)									
Speed (mm/s)	0.1	0.3	0.5	0.7	1	0.1	0.3	0.5		
0	40	40	35	35	35	14	14	14		
20	40	40	35	35	35	14	14	14		
50	40	40	35	35	35	14	14	14		
80	40	40	35	35	30	14	14	14		
110	40	40	35	35	30	14	14	14		
140	40	40	35	35	28	14	14	12		
170	40	40	32	32	24	12	12	10		
200	40	35	28	25	18	10	8	7		
225	40	25	16	12	10	6	4			

■ RCP6/RCP6S-SA7R

Lead 24

Orientation	Horizontal					Vertical				
	Acceleration (G)									
Speed (mm/s)	0.1	0.3	0.5	0.7	1	0.1	0.3	0.5		
0	37	37	22	16	14	3	3	3		
200	37	37	22	16	14	3	3	3		
420	37	30	18	16	14	3	3	3		
640	37	18	15	10	9	3	3	3		
860		12	10	3	2		3	2.5		
1080		2						0.5		

Lead 16

Orientation	Horizontal					Vertical				
	Acceleration (G)									
Speed (mm/s)	0.1	0.3	0.5	0.7	1	0.1	0.3	0.5		
0	46	46	35	28	27	8	8	8		
140	46	46	35	28	27	8	8	8		
280	46	46	35	25	21	8	8	8		
420	46	30	20	15	10	6	5	4.5		
560	35	20	13	10	6	5	4	3		
700	20	13	6	3	2	3	2	1.5		
840		4	1							

Lead 8

Orientation	Horizontal					Vertical				
	Acceleration (G)									
Speed (mm/s)	0.1	0.3	0.5	0.7	1	0.1	0.3	0.5		
0	51	51	45	40	40	16	16	16		
70	51	51	45	40	40	16	16	16		
140	51	51	40	38	35	16	16	16		
210	51	45	35	30	24	11	10	9.5		
280	51	35	25	20	15	9	8	7		
350	40	20	3	1		7	4	1		
420	30	2				4				

Lead 4

Orientation	Horizontal					Vertical				
	Acceleration (G)									
Speed (mm/s)	0.1	0.3	0.5	0.7	1	0.1	0.3	0.5		
0	55	51	45	40	40	25	25	25		
35	55	51	45	40	40	25	25	25		
70	55	51	45	40	40	25	25	25		
105	55	51	45	40	35	22	20	19		
140	55	45	35	30	25	16	14	12		
175	55	30	16			11	7	5		
210	40					4				

■ RCP6/RCP6S-SA8R

Lead 30

Orientation	Horizontal					Vertical				
	Acceleration (G)									
Speed (mm/s)	0.1	0.3	0.5	0.7	1	0.1	0.3	0.5		
0	26	24	18	15	13	3	3	3		
100	26	24	18	15	13	3	3	3		
200	26	24	16	15	13	2	2	2		
400	24	20	13	12	11	1.5	1.5	1		
650	21	14	10	9	8	1	1	1		
850		9	6	4	2		1	1		
1000		5	3	2	1					
1200		1								

Lead 20

Orientation	Horizontal					Vertical				
	Acceleration (G)									
Speed (mm/s)	0.1	0.3	0.5	0.7	1	0.1	0.3	0.5		
0	55	51	35	33	30	4	4	4		
50	55	51	35	33	30	4	4	4		
100	55	51	35	33	30	4	4	4		
200	55	51	35	33	25	4	4	4		
300	55	51	35	24	16	4	4	4		
400	45	35	22	18	12	2	2	2		
650	40	20	9	4	3	2	2	2		
800		10	3	1	0.5	1	0.5			
900		7	1							
1000		4								

Lead 10

Orientation	Horizontal					Vertical				
	Acceleration (G)									
Speed (mm/s)	0.1	0.3	0.5	0.7	1	0.1	0.3	0.5		
0	70	70	70	70	65	25	25	25		
50	70	70	70	70	65	25	25	25		
100	70	70	70	70	65	25	25	25		
200	70	60	50	40	35	14	14	14		
300	70	45	30	20	20	7	7	7		
400	65	15	9	4	1	3	2	1		
450	45	11	2			1	0.5			
500	25	4								

Lead 5

Tables of Payload by Speed/Acceleration

RCP6 Series

WSA□C: Wide Slider Type, Motor Coupled Specification

High-output Setting Enabled

Please refer to the RCP6 manual regarding dedicated tables of RCP6(S)-WSA10C/WSA12C/WSA14C with disabled high-output setting.

■ RCP6/RCP6S-WSA10C

Lead 16

Orientation	Horizontal					Vertical				
	Acceleration (G)									
Speed (mm/s)	0.1	0.3	0.5	0.7	1	0.1	0.3	0.5	0.7	1
0	4	4	3	3	2.5					
140	4	4	3	3	2.5					
280	4	4	3	3	2.5					
420	4	4	3	3	2.5					
560	4	4	3	1.5	1.5					
700	4	4	3	0.5	0.5					
840		1	0.5							
980										
1120										
1260										

Lead 10

Orientation	Horizontal					Vertical				
	Acceleration (G)									
Speed (mm/s)	0.1	0.3	0.5	0.7	1	0.1	0.3	0.5	0.7	1
0	15	15	13	13	12					
85	15	15	13	13	12					
175	15	15	13	12	10					
260	15	15	13	10	8					
350	15	15	13	8	5					
435	15	15	10	7	4					
525	15	10	5	3	2					
610	15	5	2	1						
700										
785										

Lead 5

Orientation	Horizontal					Vertical				
	Acceleration (G)									
Speed (mm/s)	0.1	0.3	0.5	0.7	1	0.1	0.3	0.5	0.7	1
0	28	25	22	20	20	3	3	3		
40	28	25	22	20	20	3	3	3		
85	28	25	22	20	20	3	3	3		
130	28	25	22	20	20	3	3	3		
175	28	25	22	20	20	3	3	3		
215	28	25	22	20	18	3	3	3		
260	28	25	22	20	14	3	3	3		
305	28	22	18	14	10	2	1.5	1.5		
350	28	18	11	7	6	1				
390	28	12	7	4	2					

Lead 2.5

Orientation	Horizontal					Vertical				
	Acceleration (G)									
Speed (mm/s)	0.1	0.3	0.5	0.7	1	0.1	0.3	0.5	0.7	1
0	40	40	40	35	30	10	10	10		
20	40	40	40	35	30	10	10	10		
40	40	40	40	35	30	10	10	10		
65	40	40	40	35	30	10	10	10		
85	40	40	40	35	30	10	10	10		
105	40	40	35	35	30	10	10	10		
130	40	40	35	30	30	10	10	9		
150	40	35	35	30	30	7	7	7		
175	40	35	35	30	25	3	3	3		
195	40	35	30	26	18					

■ RCP6/RCP6S-WSA12C

Lead 20

Orientation	Horizontal					Vertical				
	Acceleration (G)									
Speed (mm/s)	0.1	0.3	0.5	0.7	1	0.1	0.3	0.5	0.7	1
0	12	12	12	11	11					
160	12	12	12	11	11					
320	12	12	12	11	9					
480	12	12	12	11	9					
640		12	10	9	8					
800		10	9							
960										
1120										
1280										
1440										

Lead 12

Orientation	Horizontal					Vertical				
	Acceleration (G)									
Speed (mm/s)	0.1	0.3	0.5	0.7	1	0.1	0.3	0.5	0.7	1
0	25	25	18	16	12					
100	25	25	18	16	12					
200	25	25	18	16	10					
285	25	25	18	12	8					
400	20	20	14	10	6					
500	15	15	8	6	4					
600	10	10	6	3	2					

Lead 6

Orientation	Horizontal					Vertical				
	Acceleration (G)									
Speed (mm/s)	0.1	0.3	0.5	0.7	1	0.1	0.3	0.5	0.7	1
0	40	40	35	30	25	9	9	9		
50	40	40	35	30	25	9	9	9		
100	40	40	35	30	25	9	9	9		
140	40	40	35	25	25	9	9	9		
200	40	40	30	25	20	9	9	9		
250	40	40	27.5	22.5	18	9	8	8		
290	40	35	25	20	14	5	5	4		
350	40	28	14	12	10	2	2	1		
400	30	18	10	6	5	0.5				
450	25	8	3							

Lead 3

Orientation	Horizontal					Vertical				
	Acceleration (G)									
Speed (mm/s)	0.1	0.3	0.5	0.7	1	0.1	0.3	0.5	0.7	1
0	60	56	50	45	40	18	18	18		
25	60	56	50	45	40	18	18	18		
50	60	56	50	45	40	18	18	18		
65	60	56	46	41	40	18	18	18		
100	60	56	46	41	40	18	18	18		
125	60	56	46	40	30	18	18	10		
150	60	50	40	30	25	14	14	6		
180	60	40	35	25	20	11	11	5		
200	60	35	30	20	14	7	6	4.5		
225	40	16	16	10	6	5	3	2		

■ RCP6/RCP6S-WSA14C

Lead 24

Orientation	Horizontal					Vertical				
	Acceleration (G)									
Speed (mm/s)	0.1	0.3	0.5	0.7	1	0.1	0.3	0.5	0.7	1
0	25	25	23	20	17					
140	25	25	23	20	17					
420	25	25	23	20	15					
560	20	19	14	12	9					
700	20	10	6	6	6					

Lead 16

Orientation	Horizontal					Vertical				
	Acceleration (G)									
Speed (mm/s)	0.1	0.3	0.5	0.7	1	0.1	0.3	0.5	0.7	1
0	50	42	40	32	30					
140	50	42	40	32	30					
280	50	42	35	23	17					
420	47	25	18	14	10					
560	12	10	5	3	2					

Lead 8

Orientation	Horizontal					Vertical				
	Acceleration (G)									
Speed (mm/s)	0.1	0.3	0.5	0.7	1	0.1	0.3	0.5	0.7	1
0	65	65	55	50	45	14	14	14		
70	65	65	55	50	45	14	14	14		
140	65	65	55	46	45	12	12	12		
210	65	65	45	36	22	10	10	9		
280	65	39	27	18	12	8	5	4		
350	61	19	10			2				
420	20	6								

Lead 4

Orientation	Horizontal					Vertical				
	Acceleration (G)									
Speed (mm/s)	0.1	0.3	0.5	0.7	1	0.1	0.3	0.5	0.7	1
0	80	80	70	65	60	26	26	26		
35	80	80	70	65	60	26	26	26		
70	80	80	70	65	60	26	26	26		
105	80	80	60	50	40	22	20	18		
140	80	50	30	20	15	16	12	10		
175	50	15				6	1			
210	20									

■ RCP6/RCP6S-WSA16C

Lead 20

Orientation	Horizontal					Vertical				
	Acceleration (G)									
Speed (mm/s)	0.1	0.3	0.5	0.7	1	0.1	0.3	0.5	0.7	1
0	50	35	28	24	20					
120	50	35	28	24	20					
240	50	35	28	24	16					
365	50	35	28	20	12					
480	40	14	4	2						
550	40	4								
600	30									
665	18									
720	18									

Lead 10

Orientation	Horizontal					Vertical				
	Acceleration (G)									
Speed (mm/s)	0.1	0.3	0.5	0.7	1	0.1	0.3	0.5	0.7	1
0	70	70	60	60	60	15	15	15		
80	70	70	60	60	60	15	15	15		
160	70	70	55	50	45	15	15	15		
210	70	70	55	50	40	5	4	4		
240	70	55	50	35	30	2				
270	70	40	30	24	20					
330	70	14	2							
365	70									
405	40									
450	22									

Lead 5

Orientation	Horizontal					Vertical				
	Acceleration (G)									
Speed (mm/s)	0.1	0.3	0.							

RCP6 Series WSA□R: Wide Slider Type, Side-mounted Motor Specification

High-output Setting Enabled

Please refer to the RCP6 manual regarding dedicated tables of RCP6(S)-WSA10R/WSA12R/WSA14R with disabled high-output setting.

■ RCP6/RCP6S-WSA10R

Lead 16

Orientation	Horizontal					Vertical		
	Acceleration (G)							
Speed (mm/s)	0.1	0.3	0.5	0.7	1	0.1	0.3	0.5
0	4	4	3	3	2.5			
140	4	4	3	3	2.5			
280	4	4	3	3	2.5			
420	4	4	3	3	2.5			
560	4	4	3	1.5	1.5			
700	4	4	3	0.5	0.5			
840		1	0.5					
980								
1120								
1260								

Lead 10

Orientation	Horizontal					Vertical		
	Acceleration (G)							
Speed (mm/s)	0.1	0.3	0.5	0.7	1	0.1	0.3	0.5
0	15	15	13	13	12			
85	15	15	13	13	12			
175	15	15	13	12	10			
260	15	15	13	10	8			
350	15	15	13	8	5			
435	15	15	10	7	4			
525	14	10	5	3	2			
610		5	2	1				
700								
785								

Lead 5

Orientation	Horizontal					Vertical		
	Acceleration (G)							
Speed (mm/s)	0.1	0.3	0.5	0.7	1	0.1	0.3	0.5
0	28	25	22	20	20	3	3	3
40	28	25	22	20	20	3	3	3
85	28	25	22	20	20	3	3	3
130	28	25	22	20	20	3	3	3
175	28	25	22	20	20	3	3	3
215	28	25	22	20	16	3	3	3
260	28	25	20	16	12	2	2	2.5
305	28	20	12	10	8	1	0.5	0.5
350	28	14	6	4	3			
390	28	6	1					

Lead 2.5

Orientation	Horizontal					Vertical		
	Acceleration (G)							
Speed (mm/s)	0.1	0.3	0.5	0.7	1	0.1	0.3	0.5
0	40	40	40	35	30	10	10	10
20	40	40	40	35	30	10	10	10
40	40	40	36	35	30	10	10	10
65	40	40	36	35	30	10	10	10
85	40	40	36	35	30	10	10	10
105	40	40	35	35	30	10	10	10
130	40	40	35	30	30	7	7	7
150	40	35	35	30	30	4	4	4
175	40	34	32	24	20	1	1	1
195	40	20	14	12	11			

■ RCP6/RCP6S-WSA12R

Lead 20

Orientation	Horizontal					Vertical		
	Acceleration (G)							
Speed (mm/s)	0.1	0.3	0.5	0.7	1	0.1	0.3	0.5
0	12	8	6	4	3			
160	12	8	6	4	3			
320	12	8	6	4	3			
480	12	8	6	4	2			
640		8	6	4	1			
800		7	4					
960								
1120								
1280								
1440								

Lead 12

Orientation	Horizontal					Vertical		
	Acceleration (G)							
Speed (mm/s)	0.1	0.3	0.5	0.7	1	0.1	0.3	0.5
0	25	25	18	16	10			
100	25	25	18	16	10			
200	25	25	18	16	10			
285	25	25	18	12	8			
400	20	20	14	10	6			
500	15	15	8	6	4			
600	10	6	6	3	2			

Lead 6

Orientation	Horizontal					Vertical		
	Acceleration (G)							
Speed (mm/s)	0.1	0.3	0.5	0.7	1	0.1	0.3	0.5
0	40	40	35	30	25	9	9	9
50	40	40	35	30	25	9	9	9
100	40	40	35	30	25	9	9	9
140	40	40	35	25	25	9	9	9
200	40	40	30	25	20	9	9	8
250	40	40	27.5	22.5	18	9	8	4
290	40	35	25	20	14	5	5	4
350	40	28	14	12	10	2	2	1
400	30	18	10	6	5	1		
450	25	8	3					

Lead 3

Orientation	Horizontal					Vertical		
	Acceleration (G)							
Speed (mm/s)	0.1	0.3	0.5	0.7	1	0.1	0.3	0.5
0	60	56	50	45	40	16	16	16
25	60	56	50	45	40	16	16	16
50	60	56	50	45	40	16	16	16
65	60	56	46	41	40	16	16	16
100	60	56	46	41	40	16	16	16
125	60	56	46	40	30	16	14	10
150	60	50	40	30	25	12	10	6
180	60	40	35	25	20	8	6	5
200	60	35	30	20	14	5	5	4
225	40	16	16	10	6	2		

■ RCP6/RCP6S-WSA14R

Lead 24

Orientation	Horizontal					Vertical		
	Acceleration (G)							
Speed (mm/s)	0.1	0.3	0.5	0.7	1	0.1	0.3	0.5
0	25	23	19	14	11			
140	25	23	19	14	11			
420	25	23	19	13	8			
560	20	19	14	10	5			
700	20	8	6	6	3			

Lead 16

Orientation	Horizontal					Vertical		
	Acceleration (G)							
Speed (mm/s)	0.1	0.3	0.5	0.7	1	0.1	0.3	0.5
0	50	42	40	32	30			
140	50	42	40	32	30			
280	50	42	35	23	17			
420	47	25	18	14	10			
560	12	10	5	3	2			

Lead 8

Orientation	Horizontal					Vertical		
	Acceleration (G)							
Speed (mm/s)	0.1	0.3	0.5	0.7	1	0.1	0.3	0.5
0	65	65	55	50	45	14	14	14
70	65	65	55	50	45	14	14	14
140	65	65	51	46	45	12	12	12
210	65	65	45	31	22	8	6	6
280	65	31	21	14	6	6	4	2
350	35	8				1		
420	7							

Lead 4

Orientation	Horizontal					Vertical		
	Acceleration (G)							
Speed (mm/s)	0.1	0.3	0.5	0.7	1	0.1	0.3	0.5
0	80	80	70	65	60	26	26	26
35	80	80	70	65	60	26	26	26
70	80	80	70	65	60	26	26	26
105	80	80	60	50	40	22	20	18
140	80	50	10	6	6	13	8	3
175	40	5				4		
210								

■ RCP6/RCP6S-WSA16R

Lead 20

Orientation	Horizontal					Vertical		
	Acceleration (G)							
Speed (mm/s)	0.1	0.3	0.5	0.7	1	0.1	0.3	0.5
0	30	30	28	24	20			
120	30	30	28	24	20			
240	30	30	28	20	16			
365	30	28	18	12	6			
480	30	6						
550	14							
600	2							
665								
720								

Lead 10

Orientation	Horizontal					Vertical		
	Acceleration (G)							
Speed (mm/s)	0.1	0.3	0.5	0.7	1	0.1	0.3	0.5
0	70	70	60	60	60	15	15	15
80	70	70	60	60	60	15	15	15
160	70	70	55	45	45	10	10	10
210	70	65	45	30	28	2	2	1
240	70	30	22	14	10			
270	70	12	6	4				
330	35							
365	12							
405								
450								

Lead 5

Orientation	Horizontal					Vertical		
	Acceleration (G)							
Speed (mm/s)	0.1	0.3	0.5	0.7	1	0.1	0.3	0.5
0	100	90	90	90	90	45	45	45
60	100	90	90	90	90	45	45	45
95	100	90	90	80	80	27	27	27
120	100	90	65	50	45	7	7	7
145	80					1		
160	35							
170	8							
195								

Tables of Payload by Speed/Acceleration

RCP6 Series

RRA□C: Radial Cylinder Type, Motor Coupled Specification

High-output Setting Enabled

Please refer to the RCP6 manual regarding dedicated tables of RCP6(S)-RRA4C/RRA6C/RRA7C with disabled high-output setting.

RCP6/RCP6S-RRA4C

Lead 16

Orientation	Horizontal					Vertical					
	Acceleration (G)										
Speed (mm/s)	0.1	0.3	0.5	0.7	1	0.1	0.3	0.5			
0	7	7	6	5	3.5	1.5	1.5	1.5			
140	7	7	6	5	3.5	1.5	1.5	1.5			
280	7	7	6	5	3.5	1.5	1.5	1.5			
420	7	7	6	5	3.5	1.5	1.5	1.5			
560	6.5	6	5	3.5	1	1.5	1.5	1.5			
700	5.5	5	4	2.5		1	1	1			
840	4.5	3.5	3	2		1	1	1			
980		2.5	2	1.5		1	0.75				
1120			1	1	0.75			0.5			

Lead 10

Orientation	Horizontal					Vertical					
	Acceleration (G)										
Speed (mm/s)	0.1	0.3	0.5	0.7	1	0.1	0.3	0.5			
0	18	17	15	14	13	3	3	3			
85	18	17	15	14	13	3	3	3			
175	18	17	15	14	12	3	3	3			
260	18	17	13	13	12	3	3	3			
350	18	17	13	13	10	2.5	2.5	2.5			
435	18	17	13	11	9	2.5	2.5	2.5			
525	18	15	10	8	7	2.5	2.5	2.5			
610		9	7	5	4		2	2			
700		6	5	3	2		1.5	1			

Lead 5

Orientation	Horizontal					Vertical					
	Acceleration (G)										
Speed (mm/s)	0.1	0.3	0.5	0.7	1	0.1	0.3	0.5			
0	28	25	22	20	20	6	6	6			
40	28	25	22	20	20	6	6	6			
85	28	25	22	20	20	6	6	6			
130	28	25	22	20	20	6	6	6			
175	28	25	22	20	20	5	5	5			
215	28	25	22	20	20	5	5	5			
260	28	25	22	20	16	5	5	5			
305	28	22	20	16	14	5	5	5			
350	28	20	14	12	11	4.5	3	3			

Lead 2.5

Orientation	Horizontal					Vertical					
	Acceleration (G)										
Speed (mm/s)	0.1	0.3	0.5	0.7	1	0.1	0.3	0.5			
0	40	40	40	35	30	10	10	10			
20	40	40	40	35	30	10	10	10			
40	40	40	40	35	30	10	10	10			
65	40	40	40	35	30	10	10	10			
85	40	40	40	35	30	10	10	10			
105	40	40	35	35	30	10	10	10			
130	40	40	35	30	30	10	10	9			
150	40	35	35	30	30	10	9	8			
175	40	35	35	30	25	8	7	7			

RCP6/RCP6S-RRA6C

Lead 20

Orientation	Horizontal					Vertical					
	Acceleration (G)										
Speed (mm/s)	0.1	0.3	0.5	0.7	1	0.1	0.3	0.5			
0	6	6	6	5	5	1.5	1.5	1.5			
160	6	6	6	5	5	1.5	1.5	1.5			
320	6	6	6	5	3	1.5	1.5	1.5			
480	6	6	6	5	3	1.5	1.5	1.5			
640	6	4	3	2		1.5	1.5				
800		4	3			1	1				

Lead 12

Orientation	Horizontal					Vertical					
	Acceleration (G)										
Speed (mm/s)	0.1	0.3	0.5	0.7	1	0.1	0.3	0.5			
0	25	25	18	16	12	4	4	4			
100	25	25	18	16	12	4	4	4			
200	25	25	18	16	10	4	4	4			
300	25	25	18	12	8	4	4	4			
400	20	20	14	10	6	4	4	4			
500	15	15	8	6	4	4	3.5	3			
600	10	10	6	3	2	4	3	2			
700		6	2			2	1				

Lead 6

Orientation	Horizontal					Vertical					
	Acceleration (G)										
Speed (mm/s)	0.1	0.3	0.5	0.7	1	0.1	0.3	0.5			
0	40	40	35	30	25	10	10	10			
50	40	40	35	30	25	10	10	10			
100	40	40	35	30	25	10	10	10			
150	40	40	35	25	25	10	10	10			
200	40	40	30	25	20	10	10	10			
250	40	40	27.5	22.5	18	10	9	8			
300	40	35	25	20	14	6	6	6			
350	40	30	14	12	10	5	5	5			
400	30	18	10	6	5	4	3	3			
450	25	8	3			2	2	1			

Lead 3

Orientation	Horizontal					Vertical					
	Acceleration (G)										
Speed (mm/s)	0.1	0.3	0.5	0.7	1	0.1	0.3	0.5			
0	60	60	50	45	40	20	20	20			
25	60	60	50	45	40	20	20	20			
50	60	60	50	45	40	20	20	20			
75	60	60	50	45	40	20	20	20			
100	60	60	50	45	40	20	20	20			
125	60	60	50	40	30	18	14	10			
150	60	50	40	30	25	14	10	6			
175	60	40	35	25	20	12	6	5			
200	60	35	30	20	14	8	5	4.5			
225	40	16	16	10	6	5	5	4			

RCP6/RCP6S-RRA7C

Lead 24

Orientation	Horizontal					Vertical					
	Acceleration (G)										
Speed (mm/s)	0.1	0.3	0.5	0.7	1	0.1	0.3	0.5			
0	20	20	18	15	12	3	3	3			
200	20	20	18	15	12	3	3	3			
420	20	20	18	15	10	3	3	3			
640	15	14	9	7	4	3	3	2			
860		5	1	1							

Lead 16

Orientation	Horizontal					Vertical					
	Acceleration (G)										
Speed (mm/s)	0.1	0.3	0.5	0.7	1	0.1	0.3	0.5			
0	50	50	40	35	30	8	8	8			
140	50	50	40	35	30	8	8	8			
280	50	50	35	25	20	8	7	7			
420	50	25	18	14	10	6	4.5	4			
560	12	10	5	3	2	4	2	1			
700	3	2									

Lead 8

Orientation	Horizontal					Vertical					
	Acceleration (G)										
Speed (mm/s)	0.1	0.3	0.5	0.7	1	0.1	0.3	0.5			
0	60	60	50	45	40	18	18	18			
70	60	60	50	45	40	18	18	18			
140	60	60	50	45	40	16	16	12			
210	60	60	40	31	26	10	10	9			
280	60	34	22	15	11	8	7	6			
350	60	14	5	1		3	2.5	1.5			
420	15	1				1					

Lead 4

Orientation	Horizontal					Vertical					
	Acceleration (G)										
Speed (mm/s)	0.1	0.3	0.5	0.7	1	0.1	0.3	0.5			
0	80	80	70	65	60	28	28	28			
35	80	80	70	65	60	28	28	28			
70	80	80	70	65	60	28	28	28			
105	80	80	60	50	40	22	20	18			
140	80	50	30	20	15	16	12	10			
175	50	15				8.5	4				
210	20					1.5					

RCP6/RCP6S-RRA8C

Lead 20

Orientation	Horizontal		Orientation	Vertical	
	Acceleration (G)			Acceleration (G)	
Speed (mm/s)	0.2		Speed (mm/s)	0.2	
0	30		0	5	
240	30		5	5	
270	30		100	5	
300	30		150	5	
360	24		180	5	
420	16		200	5	
450	12		240	5	
480	10		300	5	
510	8		360	5	
540	6		400	3	
600	5		420	2.5	
			450	2	

Lead 10

Orientation	Horizontal		Orientation	Vertical	
	Acceleration (G)			Acceleration (G)	
Speed (mm/s)	0.2		Speed (mm/s)	0.2	
0	60		0	40	
150	60		88	40	
200	45		100	33	
240	40		110	28	
300	10		120	23	
			130	18	
			140	15	
			150	11	
			160	10	
			170	8	
			180	7	
			190	5	
			200	4	
			220	3	
			250	2	

Lead 5

Orientation	Horizontal		Orientation	Vertical	
	Acceleration (G)			Acceleration (G)	
Speed (mm/s)	0.1		Speed (mm/s)	0.1	
0	100		0	70	
90	100		48	70	
120	100		60	50	
130	90		70	35	
140	75		80	25	
150	60		90	20	
			100	15	
			120	10	
			150	2	

RCP6 Series

RRA□R: Radial Cylinder Type, Side-mounted Motor Specification

High-output Setting Enabled

Please refer to the RCP6 manual regarding dedicated tables of RCP6(S)-RRA4R/RRA6R/RRA7R with disabled high-output setting.

■ RCP6/RCP6S-RRA4R

Lead 16

Orientation	Horizontal					Vertical				
Speed (mm/s)	Acceleration (G)									
	0.1	0.3	0.5	0.7	1	0.1	0.3	0.5		
0	5	5	4.5	3	2.5	1	1	1	1	1
140	5	5	4.5	3	2.5	1	1	1	1	1
280	5	5	4.5	3	2	1	1	1	1	1
420	5	5	4.5	3	2	1	1	1	1	1
560	5	5	4.5	2.5	2	1	1	1	1	1
700	4.5	3.5	2	1.5	1	1	1	1	1	1
840	3	2.5	1	0.5		0.5	0.5	0.5		

Lead 10

Orientation	Horizontal					Vertical				
Speed (mm/s)	Acceleration (G)									
	0.1	0.3	0.5	0.7	1	0.1	0.3	0.5		
0	13	13	12	10	8	2.5	2.5	2.5	2.5	2.5
85	13	13	12	10	8	2.5	2.5	2.5	2.5	2.5
175	13	13	12	10	8	2.5	2.5	2.5	2.5	2.5
260	13	13	12	10	6	2.5	2.5	2.5	2.5	2.5
350	13	12	12	8	5	2.5	2.5	2.5	2.5	2.5
435	13	10	10	6	4	2.5	2.5	2.5	2.5	2.5
525	13	8	6	3	2	2.5	2.5	2		
610		5	2					2	1.5	

Lead 5

Orientation	Horizontal					Vertical				
Speed (mm/s)	Acceleration (G)									
	0.1	0.3	0.5	0.7	1	0.1	0.3	0.5		
0	28	25	22	20	18	5	5	5	5	5
40	28	25	22	20	18	5	5	5	5	5
85	28	25	22	20	18	5	5	5	5	5
130	28	25	22	20	18	5	5	5	5	5
175	28	25	22	20	18	5	5	5	5	5
215	28	25	22	20	18	5	5	5	5	5
260	28	24	20	16	12	5	5	5	5	5
305	25	20	16	12	8	5	4	4	4	4
350	22	16	10	8	6	3.5	3	3	3	3

Lead 2.5

Orientation	Horizontal					Vertical				
Speed (mm/s)	Acceleration (G)									
	0.1	0.3	0.5	0.7	1	0.1	0.3	0.5		
0	40	40	40	35	30	10	10	10	10	10
20	40	40	40	35	30	10	10	10	10	10
40	40	40	40	35	30	10	10	10	10	10
65	40	40	40	35	30	10	10	10	10	10
85	40	40	40	35	30	10	10	10	10	10
105	40	40	35	35	30	10	10	10	10	10
130	40	40	35	30	30	10	10	8		
150	40	35	35	30	30	8	8	7		
175	40	35	35	30	25	7.5	7	6		

■ RCP6/RCP6S-RRA6R

Lead 20

Orientation	Horizontal					Vertical				
Speed (mm/s)	Acceleration (G)									
	0.1	0.3	0.5	0.7	1	0.1	0.3	0.5		
0	6	6	6	5	5	1.5	1.5	1.5	1.5	1.5
160	6	6	6	5	5	1.5	1.5	1.5	1.5	1.5
320	6	6	6	5	3	1.5	1.5	1.5		
480	6	6	6	5	3	1.5	1.5	1.5		
640	6	4	3	2		1.5	1.5			
800	4	3				1	1			
960										
1120										
1280										
1440										

Lead 12

Orientation	Horizontal					Vertical				
Speed (mm/s)	Acceleration (G)									
	0.1	0.3	0.5	0.7	1	0.1	0.3	0.5		
0	25	25	18	16	12	4	4	4	4	4
100	25	25	18	16	12	4	4	4	4	4
200	25	25	18	16	10	4	4	4	4	4
300	25	25	18	12	8	4	4	4	4	4
400	20	20	14	10	6	4	4	4	4	4
500	15	15	8	6	4	4	3.5	3		
600	10	10	6	3	2	4	3	2		
700		6	2				2	1		

Lead 6

Orientation	Horizontal					Vertical				
Speed (mm/s)	Acceleration (G)									
	0.1	0.3	0.5	0.7	1	0.1	0.3	0.5		
0	40	40	35	30	25	10	10	10	10	10
50	40	40	35	30	25	10	10	10	10	10
100	40	40	35	30	25	10	10	10	10	10
150	40	40	35	25	25	10	10	10	10	10
200	40	40	30	25	20	10	10	10	10	10
250	40	40	27.5	22.5	18	10	9	8		
300	40	35	25	20	14	6	6	6		
350	40	30	14	12	10	5	5	5		
400	30	18	10	6	5	4	3	3		
450	25	8	3			2	2	1		

Lead 3

Orientation	Horizontal					Vertical				
Speed (mm/s)	Acceleration (G)									
	0.1	0.3	0.5	0.7	1	0.1	0.3	0.5		
0	60	60	50	45	40	20	20	20	20	20
25	60	60	50	45	40	20	20	20	20	20
50	60	60	50	45	40	20	20	20	20	20
75	60	60	50	45	40	20	20	20	20	20
100	60	60	50	45	40	20	20	20	20	20
125	60	60	50	40	30	18	14	10		
150	60	50	40	30	25	14	10	6		
175	60	40	35	25	20	12	6	5		
200	60	35	30	20	14	8	5	4.5		
225	40	16	16	10	6	5	5	4		

■ RCP6/RCP6S-RRA7R

Lead 24

Orientation	Horizontal					Vertical				
Speed (mm/s)	Acceleration (G)									
	0.1	0.3	0.5	0.7	1	0.1	0.3	0.5		
0	20	20	18	15	12	3	3	3	3	3
200	20	20	18	15	12	3	3	3	3	3
420	20	20	18	15	10	3	3	3		
640	15	14	9	7	4	3	3	2		
860	3	1								

Lead 16

Orientation	Horizontal					Vertical				
Speed (mm/s)	Acceleration (G)									
	0.1	0.3	0.5	0.7	1	0.1	0.3	0.5		
0	50	50	40	35	30	8	8	8	8	8
140	50	50	40	35	30	8	8	8	8	8
280	50	50	35	25	20	8	7	7		
420	50	25	18	14	10	4.5	4.5	4		
560	12	10	5	3	2	2	1	1		

Lead 8

Orientation	Horizontal					Vertical				
Speed (mm/s)	Acceleration (G)									
	0.1	0.3	0.5	0.7	1	0.1	0.3	0.5		
0	60	60	50	45	40	18	18	18	18	18
70	60	60	50	45	40	18	18	18	18	18
140	60	60	50	45	40	16	16	12		
210	60	60	40	31	26	10	10	9		
280	60	26	16	10	8	6	5	3		
350	30	3				3	1			
420	2									

Lead 4

Orientation	Horizontal					Vertical				
Speed (mm/s)	Acceleration (G)									
	0.1	0.3	0.5	0.7	1	0.1	0.3	0.5		
0	80	80	70	65	60	28	28	28	28	28
35	80	80	70	65	60	28	28	28	28	28
70	80	80	70	65	60	28	28	28	28	28
105	80	80	60	50	40	22	20	18		
140	80	50	10	6	6	13	8	3		
175	40	5				3				

■ RCP6/RCP6S-RRA8R

Lead 20

Orientation	Horizontal		Orientation	Vertical	
Speed (mm/s)	Acceleration (G)		Speed (mm/s)	Acceleration (G)	
	0.2	0.2		0.2	0.2
0	30		0	5	
300	30		300	5	
350	14		330	3.5	
400	6		360	2	
			400	0.5	

Lead 10

Orientation	Horizontal		Orientation	Vertical	
Speed (mm/s)	Acceleration (G)		Speed (mm/s)	Acceleration (G)	
	0.2	0.2		0.2	0.2
0	60		0	40	
160	60		80	40	
170	40		90	34	
180	25		100	28	
190	15		110	23	
200	12		120	18	
			130	15	
			140	12	
			150	10	
			160	8	
			170	6	
			180	4	
			190	3	
			200	2	

Lead 5

Orientation	Horizontal		Orientation	Vertical	
Speed (mm/s)	Acceleration (G)		Speed (mm/s)	Acceleration (G)	
	0.1	0.1		0.1	0.1
0	100		0	70	
90	100		45	70	
100	75		60	45	
			70	35	
			80	25	
			90	16	
			100	10	

Tables of Payload by Speed/Acceleration

RCP6 Series

WRA□C: Wide Radial Cylinder Type, Motor Coupled Specification

High-output Setting Enabled

Please refer to the RCP6 manual regarding dedicated tables of RCP6(S)-WRA10C/WRA12C/WRA14C with disabled high-output setting.

■ RCP6/RCP6S-WRA10C

Lead 16

Orientation	Horizontal					Vertical		
	Acceleration (G)							
Speed (mm/s)	0.1	0.3	0.5	0.7	1	0.1	0.3	0.5
0	4	4	3.5	2.5	1.5			
140	4	4	3.5	2.5	1.5			
280	4	4	3.5	2.5	1			
420	4	4	3.5	2	0.5			
560			2.5	2.5				
700			0.5					

Lead 10

Orientation	Horizontal					Vertical		
	Acceleration (G)							
Speed (mm/s)	0.1	0.3	0.5	0.7	1	0.1	0.3	0.5
0	14.5	14.5	13	12.5	12			
85	14.5	14.5	13	12.5	12			
175	14.5	14.5	12.5	11.5	9.5			
260	14.5	14.5	12.5	8.5	6.5			
350	14.5	14.5	11.5	7.5	3.5			
435	14.5	12.5	7.5	4.5	2.5			
525	10.5	7.5	2.5	0.5				

Lead 5

Orientation	Horizontal					Vertical		
	Acceleration (G)							
Speed (mm/s)	0.1	0.3	0.5	0.7	1	0.1	0.3	0.5
0	28	25	22	20	20	5	5	5
40	28	25	22	20	20	5	5	5
85	28	25	22	20	20	5	5	5
130	28	25	22	20	20	5	5	5
175	28	25	22	20	20	5	5	5
215	28	25	22	20	13.5	3	3	3
260	28	25	20.5	15.5	12.5	1	1	1
305	28	17.5	13.5	12.5	7.5			
350	28	9.5	5.5	4.5	2.5			

Lead 2.5

Orientation	Horizontal					Vertical		
	Acceleration (G)							
Speed (mm/s)	0.1	0.3	0.5	0.7	1	0.1	0.3	0.5
0	40	40	40	35	30	10	10	10
20	40	40	40	35	30	10	10	10
40	40	40	40	35	30	10	10	10
65	40	40	40	35	30	10	10	10
85	40	40	40	35	30	10	10	10
105	40	40	35	35	30	10	10	10
130	40	40	35	30	30	8.5	8.5	8.5
150	40	35	35	30	30	5.5	5.5	5.5
175	40	33.5	29.5	27.5	17.5	2.5	2.5	0.5

■ RCP6/RCP6S-WRA12C

Lead 20

Orientation	Horizontal					Vertical		
	Acceleration (G)							
Speed (mm/s)	0.1	0.3	0.5	0.7	1	0.1	0.3	0.5
0	7.5	7.5	5.5	5.5	5.5			
160	7.5	7.5	5.5	5.5	5.5			
320	7.5	7.5	4.5	2.5	1.5			
480	7.5	4.5	3.5	0.5	0.5			
640		4.5	3.5					
800		0.5	0.5					

Lead 12

Orientation	Horizontal					Vertical		
	Acceleration (G)							
Speed (mm/s)	0.1	0.3	0.5	0.7	1	0.1	0.3	0.5
0	30	25	18	16	12			
80	30	25	18	16	12			
200	30	25	18	16	10			
320	30	25	18	12	8			
440	25	20	13.5	10	6			
560		15	8	6	4			

Lead 6

Orientation	Horizontal					Vertical		
	Acceleration (G)							
Speed (mm/s)	0.1	0.3	0.5	0.7	1	0.1	0.3	0.5
0	55	40	35	30	25	7.5	7.5	7.5
40	55	40	35	30	25	7.5	7.5	7.5
100	55	40	35	30	25	7.5	7.5	7.5
160	55	40	32.5	25	25	7.5	7.5	7.5
220	55	40	27.5	25	19.5	7.5	7.5	6.5
280	55	35	25	20	14	4.5	4.5	4.5
340	55	25.5	14	12	10	0.5		
400	45	12.5	10	6	3.5			

Lead 3

Orientation	Horizontal					Vertical		
	Acceleration (G)							
Speed (mm/s)	0.1	0.3	0.5	0.7	1	0.1	0.3	0.5
0	70	60	50	45	40	17.5	17.5	17.5
20	70	60	50	45	40	17.5	17.5	17.5
50	70	60	50	45	40	17.5	17.5	17.5
80	70	60	50	45	40	17.5	17.5	17.5
110	70	60	50	45	40	17.5	17.5	17.5
140	70	50	40	30	25	13.5	13.5	6
170	70	40	35	25	20	3.5	3.5	3.5
200	70	35	30	20	14	1	1	1
225	50	16	16	10	6			

■ RCP6/RCP6S-WRA14C

Lead 24

Orientation	Horizontal					Vertical		
	Acceleration (G)							
Speed (mm/s)	0.1	0.3	0.5	0.7	1	0.1	0.3	0.5
0	25	22	14	12	12			
210	25	22	14	12	12			
420	25	18	14	6	5			
630	20	8	2					

Lead 16

Orientation	Horizontal					Vertical		
	Acceleration (G)							
Speed (mm/s)	0.1	0.3	0.5	0.7	1	0.1	0.3	0.5
0	50	50	40	35	30			
140	50	50	40	35	30			
280	50	50	31	25	20			
420	50	25	14	8	6			
560	10	6						

Lead 8

Orientation	Horizontal					Vertical		
	Acceleration (G)							
Speed (mm/s)	0.1	0.3	0.5	0.7	1	0.1	0.3	0.5
0	65	65	55	50	45	15	15	15
70	65	65	55	50	45	15	15	15
140	65	65	55	50	45	15	15	11
210	65	65	40	30	25	7	5	4
280	65	30	17	9	3			
350	50	7						
420	7							

Lead 4

Orientation	Horizontal					Vertical		
	Acceleration (G)							
Speed (mm/s)	0.1	0.3	0.5	0.7	1	0.1	0.3	0.5
0	85	80	70	65	60	25	25	25
35	85	80	70	65	60	25	25	25
70	85	80	70	65	60	25	25	25
105	85	80	60	50	40	21	19	17
130	85	50	30	20	15	11	9	7
175	55	11						
210	15							

■ RCP6/RCP6S-WRA16C

Lead 20

Orientation	Horizontal
Speed (mm/s)	Acceleration (G)
	0.2
0	30
240	30
300	30
360	24
420	14
450	5

Lead 10

Orientation	Horizontal	Orientation	Vertical
Speed (mm/s)	Acceleration (G)	Speed (mm/s)	Acceleration (G)
	0.2		0.2
0	60	0	36.5
150	60	88	36.5
200	45	100	29.5
240	36	110	24.5
		120	19.5
		130	16.5
		140	14.5
		150	11
		160	9.5
		170	5.5
		180	4.5
		190	2.5
		200	0.5

Lead 5

Orientation	Horizontal	Orientation	Vertical
Speed (mm/s)	Acceleration (G)	Speed (mm/s)	Acceleration (G)
	0.1		0.1
0	100	0	70
90	100	48	70
120	58	60	50
130	24	70	35
		80	25
		90	20
		100	13

RCP6 Series

WRA□R: Wide Radial Cylinder Type, Side-mounted Motor Specification

High-output Setting Enabled

Please refer to the RCP6 manual regarding dedicated tables of RCP6(S)-WRA10R/WRA12R/WRA14R with disabled high-output setting.

■ RCP6/RCP6S-WRA10R

Lead 16

Orientation	Horizontal					Vertical				
	Acceleration (G)									
Speed (mm/s)	0.1	0.3	0.5	0.7	1	0.1	0.3	0.5	0.7	1
0	4	3.5	2.5	0.5						
140	4	3.5	2.5	0.5						
280	4	3.5	2.5	0.5						
420	4	3.5	2.5	0.5						
560		2.5	2							
700			0.5							

Lead 10

Orientation	Horizontal					Vertical				
	Acceleration (G)									
Speed (mm/s)	0.1	0.3	0.5	0.7	1	0.1	0.3	0.5	0.7	1
0	11.5	11.5	8.5	8.5	6.5					
85	11.5	11.5	8.5	8.5	6.5					
175	11.5	11.5	8.5	8.5	3.5					
260	11.5	11.5	8.5	7.5	2.5					
350	11.5	11.5	8.5	6.5	2.5					
435	11.5	8.5	6.5	3.5	1.5					
525	10.5	6.5	2.5	0.5						

Lead 5

Orientation	Horizontal					Vertical				
	Acceleration (G)									
Speed (mm/s)	0.1	0.3	0.5	0.7	1	0.1	0.3	0.5	0.7	1
0	28	25	22	20	20	5	5	5		
40	28	25	22	20	20	5	5	5		
85	28	25	22	20	20	5	5	5		
130	28	25	22	20	20	5	5	5		
175	28	25	22	20	20	5	5	5		
215	28	25	22	20	13.5	3	3	3		
260	28	25	20.5	15.5	12.5	1	1	1		
305	28	17.5	12.5	10.5	7.5					
350	28	9.5	5.5	3.5	0.5					

Lead 2.5

Orientation	Horizontal					Vertical				
	Acceleration (G)									
Speed (mm/s)	0.1	0.3	0.5	0.7	1	0.1	0.3	0.5	0.7	1
0	40	40	40	35	30	10	10	10		
20	40	40	40	35	30	10	10	10		
40	40	40	40	35	30	10	10	10		
65	40	40	40	35	30	10	10	10		
85	40	40	40	35	30	10	10	10		
105	40	40	35	35	30	10	10	10		
130	40	40	35	30	30	3.5	3.5	3.5		
150	40	35	35	30	30	1.5	1.5	1.5		
175	40	33.5	29.5	25.5	17.5					

■ RCP6/RCP6S-WRA12R

Lead 20

Orientation	Horizontal					Vertical				
	Acceleration (G)									
Speed (mm/s)	0.1	0.3	0.5	0.7	1	0.1	0.3	0.5	0.7	1
0	7.5	7.5	5.5	5.5	5.5					
160	7.5	7.5	5.5	5.5	5.5					
320	7.5	7.5	4.5	2.5	1.5					
480	7.5	4.5	3.5	0.5	0.5					
640		4.5	3.5							
800		0.5	0.5							

Lead 12

Orientation	Horizontal					Vertical				
	Acceleration (G)									
Speed (mm/s)	0.1	0.3	0.5	0.7	1	0.1	0.3	0.5	0.7	1
0	30	25	18	16	10					
80	30	25	18	16	10					
200	30	25	18	16	10					
320	30	25	18	12	8					
440	25	20	13.5	10	6					
560		13.5	8	5.5	3.5					

Lead 6

Orientation	Horizontal					Vertical				
	Acceleration (G)									
Speed (mm/s)	0.1	0.3	0.5	0.7	1	0.1	0.3	0.5	0.7	1
0	55	40	35	30	25	7.5	7.5	7.5		
40	55	40	35	30	25	7.5	7.5	7.5		
100	55	40	35	30	25	7.5	7.5	7.5		
160	55	40	32.5	25	25	7.5	7.5	7.5		
220	55	40	27.5	25	19.5	7.5	7.5	6.5		
280	55	35	25	20	14	3.5	3.5	3.5		
340	55	25.5	14	12	10					
400	45	12.5	10	6	3.5					

Lead 3

Orientation	Horizontal					Vertical				
	Acceleration (G)									
Speed (mm/s)	0.1	0.3	0.5	0.7	1	0.1	0.3	0.5	0.7	1
0	70	60	50	45	40	17.5	17.5	17.5		
20	70	60	50	45	40	17.5	17.5	17.5		
50	70	60	50	45	40	17.5	17.5	17.5		
80	70	60	50	45	40	17.5	17.5	17.5		
110	70	60	50	45	40	17.5	17.5	17.5		
140	70	50	40	30	25	13.5	10	6		
170	70	40	35	25	20	3.5	3.5	3.5		
200	70	35	30	20	14	1	1	0.5		
225	50	16	16	10	6					

■ RCP6/RCP6S-WRA14R

Lead 24

Orientation	Horizontal					Vertical				
	Acceleration (G)									
Speed (mm/s)	0.1	0.3	0.5	0.7	1	0.1	0.3	0.5	0.7	1
0	25	22	14	12	8					
210	25	22	14	12	8					
420	25	18	14	6	3					
630		8	2							

Lead 16

Orientation	Horizontal					Vertical				
	Acceleration (G)									
Speed (mm/s)	0.1	0.3	0.5	0.7	1	0.1	0.3	0.5	0.7	1
0	50	50	40	35	30					
140	50	50	40	35	30					
280	50	46	31	22	18					
420	50	22	12	8	6					
560	10	2								

Lead 8

Orientation	Horizontal					Vertical				
	Acceleration (G)									
Speed (mm/s)	0.1	0.3	0.5	0.7	1	0.1	0.3	0.5	0.7	1
0	65	65	55	50	45	15	15	15		
70	65	65	55	50	45	15	15	15		
140	65	65	55	50	45	13	13	10		
210	65	65	40	30	23	5	5	4		
280	65	25	13	7	3					
350	35									

Lead 4

Orientation	Horizontal					Vertical				
	Acceleration (G)									
Speed (mm/s)	0.1	0.3	0.5	0.7	1	0.1	0.3	0.5	0.7	1
0	85	80	70	65	60	25	23	23		
35	85	80	70	65	60	25	23	23		
70	85	80	70	65	60	25	23	23		
105	85	80	60	50	40	19	17	17		
130	85	50	10	6	6	7	4			
175	45									

■ RCP6/RCP6S-WRA16R

Lead 20

Orientation	Horizontal
Speed (mm/s)	Acceleration (G)
	0.2
0	30
240	30
300	30
360	19
420	10.5

Lead 10

Orientation	Horizontal	Orientation	Vertical
Speed (mm/s)	Acceleration (G)	Speed (mm/s)	Acceleration (G)
	0.2		0.2
0	60	0	34.5
150	60	88	34.5
200	45	100	24.5
240	18	110	19.5
		120	16.5
		130	14.5
		140	11.5
		150	7.5
		160	5.5
		170	4.5
		180	2.5

Lead 5

Orientation	Horizontal	Orientation	Vertical
Speed (mm/s)	Acceleration (G)	Speed (mm/s)	Acceleration (G)
	0.1		0.1
0	100	0	63
90	100	48	63
120	58	60	33
		70	28
		80	18
		90	9
		100	2

Tables of Payload by Speed/Acceleration

RCP6 Series

RA□C: Rod Type, Motor Coupled Specification

High-output Setting Enabled

Please refer to the RCP6 manual regarding dedicated tables of RCP6(S)-RA4C/RA6C/RA7C with disabled high-output setting.

■ RCP6/RCP6S-RA4C

Lead 16

Orientation	Horizontal					Vertical				
	Acceleration (G)									
Speed (mm/s)	0.1	0.3	0.5	0.7	1	0.1	0.3	0.5	0.7	1
0	6	6	6	4	3.5	1.5	1.5	1.5	1.5	1.5
140	6	6	6	4	3.5	1.5	1.5	1.5	1.5	1.5
280	6	6	6	4	3.5	1.5	1.5	1.5	1.5	1.5
420	6	6	6	4	3	1	1	1	1	1
560		6	6	3	3					1
700		5.5	5	2	1.5					1
840			3	1	0.5					1

Lead 10

Orientation	Horizontal					Vertical				
	Acceleration (G)									
Speed (mm/s)	0.1	0.3	0.5	0.7	1	0.1	0.3	0.5	0.7	1
0	15	15	13	13	12	2.5	2.5	2.5	2.5	2.5
85	15	15	13	13	12	2.5	2.5	2.5	2.5	2.5
175	15	15	13	13	12	2.5	2.5	2.5	2.5	2.5
260	15	15	13	13	12	2.5	2.5	2.5	2.5	2.5
350	15	15	13	13	10	2.5	2.5	2.5	2.5	2.5
435	15	15	13	11	8	2.5	2.5	2.5	2.5	2.5
525		14	10	8	6					2.5
610		9	7	5	4					2
700		6	4	3	2					1.5

Lead 5

Orientation	Horizontal					Vertical				
	Acceleration (G)									
Speed (mm/s)	0.1	0.3	0.5	0.7	1	0.1	0.3	0.5	0.7	1
0	28	25	22	20	20	5	5	5	5	5
40	28	25	22	20	20	5	5	5	5	5
85	28	25	22	20	20	5	5	5	5	5
130	28	25	22	20	20	5	5	5	5	5
175	28	25	22	20	20	5	5	5	5	5
215	28	25	22	20	20	5	5	5	5	5
260	28	25	22	20	18	5	5	5	5	5
305	28	22	20	18	15	5	5	4.5	4.5	4.5
350	28	20	15	13	11	5	4	3.5	3.5	3.5

Lead 2.5

Orientation	Horizontal					Vertical				
	Acceleration (G)									
Speed (mm/s)	0.1	0.3	0.5	0.7	1	0.1	0.3	0.5	0.7	1
0	40	40	40	35	30	10	10	10	10	10
20	40	40	40	35	30	10	10	10	10	10
40	40	40	40	35	30	10	10	10	10	10
65	40	40	40	30	30	10	10	10	10	10
85	40	40	40	30	30	10	10	10	10	10
105	40	40	35	30	30	10	10	10	10	10
130	40	40	35	30	30	8	7.5	7	7	7
150	40	35	35	30	25	6	5.5	5	5	5
175	40	30	30	25	20	5	4.5	4	4	4

■ RCP6/RCP6S-RA6C

Lead 20

Orientation	Horizontal					Vertical				
	Acceleration (G)									
Speed (mm/s)	0.1	0.3	0.5	0.7	1	0.1	0.3	0.5	0.7	1
0	6	6	6	5	5	1.5	1.5	1.5	1.5	1.5
160	6	6	6	5	5	1.5	1.5	1.5	1.5	1.5
320	6	6	6	5	3	1.5	1.5	1.5	1.5	1.5
480	6	6	6	5	3	1.5	1.5	1.5	1.5	1.5
640		6	4	3	2					1.5
800		4	3							1

Lead 12

Orientation	Horizontal					Vertical				
	Acceleration (G)									
Speed (mm/s)	0.1	0.3	0.5	0.7	1	0.1	0.3	0.5	0.7	1
0	25	25	18	16	12	4	4	4	4	4
100	25	25	18	16	12	4	4	4	4	4
200	25	25	18	16	10	4	4	4	4	4
300	25	25	18	12	8	4	4	4	4	4
400	20	20	14	10	6	4	4	4	4	4
500	15	15	8	6	4	4	3.5	3	3	3
600		10	6	3	2					3
700		6	2							2

Lead 6

Orientation	Horizontal					Vertical				
	Acceleration (G)									
Speed (mm/s)	0.1	0.3	0.5	0.7	1	0.1	0.3	0.5	0.7	1
0	40	40	35	30	25	10	10	10	10	10
50	40	40	35	30	25	10	10	10	10	10
100	40	40	35	30	25	10	10	10	10	10
150	40	40	35	25	25	10	10	10	10	10
200	40	40	30	25	20	10	10	10	10	10
250	40	40	27.5	22.5	18	10	9	8	8	8
300	40	35	25	20	14	6	6	6	6	6
350	40	30	14	12	10	5	5	5	5	5
400	30	18	10	6	5	4	3	3	3	3
450	25	8	3			2	2	1	1	1

Lead 3

Orientation	Horizontal					Vertical				
	Acceleration (G)									
Speed (mm/s)	0.1	0.3	0.5	0.7	1	0.1	0.3	0.5	0.7	1
0	60	60	50	45	40	20	20	20	20	20
50	60	60	50	45	40	20	20	20	20	20
75	60	60	50	45	40	20	20	20	20	20
100	60	60	50	45	40	20	20	20	20	20
125	60	60	50	40	30	18	14	10	10	10
150	60	50	40	30	25	14	10	6	6	6
175	60	40	35	25	20	12	6	5	5	5
200	60	35	30	20	14	8	5	4.5	4.5	4.5
225	40	16	16	10	6	5	5	4	4	4

■ RCP6/RCP6S-RA7C

Lead 24

Orientation	Horizontal					Vertical				
	Acceleration (G)									
Speed (mm/s)	0.1	0.3	0.5	0.7	1	0.1	0.3	0.5	0.7	1
0	20	20	18	15	12	3	3	3	3	3
200	20	20	18	15	12	3	3	3	3	3
400	20	20	14	12	8	3	3	3	3	3
420	20	17	12	10	6	3	3	3	3	3
600		14	6	5	4					3
640		5	3	2	1.5					2
800		5	1	1						1
860		2	0.5							1

Lead 16

Orientation	Horizontal					Vertical				
	Acceleration (G)									
Speed (mm/s)	0.1	0.3	0.5	0.7	1	0.1	0.3	0.5	0.7	1
0	50	50	40	35	30	8	8	8	8	8
140	50	50	40	35	30	8	8	8	8	8
280	50	50	35	25	20	8	7	7	7	7
420	50	25	18	14	10	6	4.5	4	4	4
560		10	5	3	2					2
700		2								1

Lead 8

Orientation	Horizontal					Vertical				
	Acceleration (G)									
Speed (mm/s)	0.1	0.3	0.5	0.7	1	0.1	0.3	0.5	0.7	1
0	60	60	50	45	40	18	18	18	18	18
70	60	60	50	45	40	18	18	18	18	18
140	60	60	50	45	40	16	16	12	12	12
210	60	60	40	31	26	10	10	9	9	9
280	60	34	20	15	11	7	5	4	4	4
350	50	12	4	1		3	2	1	1	1
420	10									

Lead 4

Orientation	Horizontal					Vertical				
	Acceleration (G)									
Speed (mm/s)	0.1	0.3	0.5	0.7	1	0.1	0.3	0.5	0.7	1
0	80	80	70	65	60	28	28	28	28	28
35	80	80	70	65	60	28	28	28	28	28
70	80	80	70	65	60	28	28	28	28	28
105	80	80	60	50	40	22	22	18	18	18
140	80	50	30	20	15	14	12	10	10	10
175	50	15				5	2			
210	20									

■ RCP6/RCP6S-RA8C

Lead 20

Orientation	Horizontal		Orientation	Vertical	
	Acceleration (G)			Acceleration (G)	
Speed (mm/s)	0.2		Speed (mm/s)	0.2	
0	30		0	5	
240	30		50	5	
270	30		100	5	
300	30		150	5	
360	24		180	5	
420	16		200	5	
450	12		240	5	
480	10		300	5	
510	8		360	5	
540	6		400	3	
600	5		420	2.5	
			450	2	

Lead 10

Orientation	Horizontal		Orientation	Vertical	
	Acceleration (G)			Acceleration (G)	
Speed (mm/s)	0.2		Speed (mm/s)	0.2	
0	60		0	40	
150	60		88	40	
200	45		100	33	
240	40		110	28	
300	10		120	23	
			130	18	
			140	15	
			150	11	
			160	10	
			170	8	
			180	7	
			190	5	
			200	4	
			220	3	
			250	2	

Lead 5

RCP6 Series

RA□R: Rod Type, Side-mounted Motor Specification

High-output Setting Enabled

Please refer to the RCP6 manual regarding dedicated tables of RCP6(S)-RA4R/RA6R/RA7R with disabled high-output setting.

■ RCP6/RCP6S-RA4R

Lead 16

Orientation	Horizontal					Vertical				
	Acceleration (G)									
Speed (mm/s)	0.1	0.3	0.5	0.7	1	0.1	0.3	0.5	0.7	1
0	5	5	4.5	3	2.5	1	1	1	1	1
140	5	5	4.5	3	2.5	1	1	1	1	1
280	5	5	4.5	3	2	1	1	1	1	1
420	5	5	4.5	3	2	1	1	1	1	1
560	5	5	4.5	2.5	2	1	1	1	1	1
700	4.5	3.5	2	1.5	1	1	1	1	1	1
840			2.5	1	0.5					0.5

Lead 10

Orientation	Horizontal					Vertical				
	Acceleration (G)									
Speed (mm/s)	0.1	0.3	0.5	0.7	1	0.1	0.3	0.5	0.7	1
0	12	12	10	10	8	2.5	2.5	2.5	2.5	2.5
85	12	12	10	10	8	2.5	2.5	2.5	2.5	2.5
175	12	12	10	10	6	2.5	2.5	2.5	2.5	2.5
260	12	12	10	10	5	2.5	2.5	2.5	2.5	2.5
350	12	12	10	8	5	2.5	2.5	2.5	2.5	2.5
435	12	10	8	6	4	2.5	2.5	2.5	2.5	2.5
525		8	6	3	2					2.5
610		5	2							2

Lead 5

Orientation	Horizontal					Vertical				
	Acceleration (G)									
Speed (mm/s)	0.1	0.3	0.5	0.7	1	0.1	0.3	0.5	0.7	1
0	25	25	22	20	18	5	5	5	5	5
40	25	25	22	20	18	5	5	5	5	5
85	25	25	22	20	18	5	5	5	5	5
130	25	25	22	18	18	5	5	5	5	5
175	25	25	22	18	16	5	5	5	5	5
215	25	25	22	16	14	5	5	5	5	5
260	25	22	20	14	12	5	5	5	5	5
305	22	20	14	12	8	4	4	4	4	4
350	20	14	10	8	6	3	2.5	2.5	2.5	2.5

Lead 2.5

Orientation	Horizontal					Vertical				
	Acceleration (G)									
Speed (mm/s)	0.1	0.3	0.5	0.7	1	0.1	0.3	0.5	0.7	1
0	40	40	40	35	30	10	10	10	10	10
20	40	40	40	35	30	10	10	10	10	10
40	40	40	40	35	30	10	10	10	10	10
65	40	40	40	30	30	10	10	10	10	10
85	40	40	35	30	30	10	10	10	10	10
105	40	40	35	30	30	10	8	8	8	8
130	40	40	35	30	30	8	8	8	8	8
150	40	35	35	30	25	6	6	6	6	6
175	40	30	30	25	20	4	4	4	4	4

■ RCP6/RCP6S-RA6R

Lead 20

Orientation	Horizontal					Vertical				
	Acceleration (G)									
Speed (mm/s)	0.1	0.3	0.5	0.7	1	0.1	0.3	0.5	0.7	1
0	6	6	5	5	5	1.5	1.5	1.5	1.5	1.5
160	6	6	5	5	5	1.5	1.5	1.5	1.5	1.5
320	6	6	5	4	3	1.5	1.5	1.5	1.5	1.5
480	6	6	5	4	3	1.5	1.5	1.5	1.5	1.5
640	4	3	3	2	1	1.5	1.5	1.5	1.5	1.5
800		3	2	2	1					1

Lead 12

Orientation	Horizontal					Vertical				
	Acceleration (G)									
Speed (mm/s)	0.1	0.3	0.5	0.7	1	0.1	0.3	0.5	0.7	1
0	25	25	18	16	12	4	4	4	4	4
100	25	25	18	16	12	4	4	4	4	4
200	25	25	18	16	10	4	4	4	4	4
285	25	25	18	12	8	4	4	4	4	4
400	20	20	14	10	6	4	4	4	4	4
500	15	15	8	6	4	4	3.5	3	3	3
600		10	6	3	2					3
700		6	2							2

Lead 6

Orientation	Horizontal					Vertical				
	Acceleration (G)									
Speed (mm/s)	0.1	0.3	0.5	0.7	1	0.1	0.3	0.5	0.7	1
0	40	40	35	30	25	10	10	10	10	10
50	40	40	35	30	25	10	10	10	10	10
100	40	40	35	30	25	10	10	10	10	10
150	40	40	35	25	25	10	10	10	10	10
200	40	40	30	25	20	10	10	10	10	10
250	40	40	27.5	22.5	18	10	9	8	8	8
300	40	35	25	20	14	6	6	6	6	6
350	40	25	14	12	10	5	5	5	5	5
400	30	16	10	6	5	4	3	3	3	3
450	25	8	3			2	2	1	1	1

Lead 3

Orientation	Horizontal					Vertical				
	Acceleration (G)									
Speed (mm/s)	0.1	0.3	0.5	0.7	1	0.1	0.3	0.5	0.7	1
0	60	60	50	45	40	20	20	20	20	20
25	60	60	50	45	40	20	20	20	20	20
50	60	60	50	45	40	20	20	20	20	20
75	60	60	50	45	40	20	20	20	20	20
100	60	60	50	45	40	20	20	20	20	20
125	60	60	50	40	30	18	14	10	10	10
150	60	50	40	30	25	14	10	6	6	6
175	60	40	35	25	20	12	6	5	5	5
200	60	35	30	20	14	8	5	4.5	4.5	4.5
225	40	16	16	10	6	5	5	4	4	4

■ RCP6/RCP6S-RA7R

Lead 24

Orientation	Horizontal					Vertical				
	Acceleration (G)									
Speed (mm/s)	0.1	0.3	0.5	0.7	1	0.1	0.3	0.5	0.7	1
0	20	20	18	15	12	3	3	3	3	3
200	20	20	18	15	12	3	3	3	3	3
400	20	20	16	12	8	3	3	3	3	3
420	20	20	15	10	6	3	3	3	3	3
600		12	8	5	3					2
640		10	6	4	2					1
800			2							

Lead 16

Orientation	Horizontal					Vertical				
	Acceleration (G)									
Speed (mm/s)	0.1	0.3	0.5	0.7	1	0.1	0.3	0.5	0.7	1
0	50	50	40	35	30	8	8	8	8	8
140	50	50	40	35	30	8	8	8	8	8
280	50	50	35	23	20	8	7	7	7	7
420	50	25	18	13	10	4.5	4.5	4	4	4
560		10	5	3	2					1

Lead 8

Orientation	Horizontal					Vertical				
	Acceleration (G)									
Speed (mm/s)	0.1	0.3	0.5	0.7	1	0.1	0.3	0.5	0.7	1
0	60	60	50	45	40	18	18	18	18	18
70	60	60	50	45	40	18	18	18	18	18
140	60	60	50	45	40	16	16	12	12	12
210	60	60	40	31	26	10	10	9	9	9
280	60	26	16	10	8	8	4	3	3	3
350	30	3				2	0.5			
420	2									

Lead 4

Orientation	Horizontal					Vertical				
	Acceleration (G)									
Speed (mm/s)	0.1	0.3	0.5	0.7	1	0.1	0.3	0.5	0.7	1
0	80	80	70	65	60	28	28	28	28	28
35	80	80	70	65	60	28	28	28	28	28
70	80	80	70	65	60	28	28	28	28	28
105	80	80	60	50	40	22	20	18	18	18
140	80	50	10	6	6	12	8	3	3	3
175	40	5				4				

■ RCP6/RCP6S-RA8R

Lead 20

Orientation	Horizontal		Orientation	Vertical	
	Acceleration (G)			Acceleration (G)	
Speed (mm/s)	0.2		Speed (mm/s)	0.2	
0	30		0	5	
300	30		300	5	
350	14		330	3.5	
400	6		360	2	
			400	0.5	

Lead 10

Orientation	Horizontal		Orientation	Vertical	
	Acceleration (G)			Acceleration (G)	
Speed (mm/s)	0.2		Speed (mm/s)	0.2	
0	60		0	40	
160	60		80	40	
170	40		90	34	
180	25		100	28	
190	15		110	23	
200	12		120	18	
			130	15	
			140	12	
			150	10	
			160	8	
			170	6	
			180	4	
			190	3	
			200	2	

Lead 5

Orientation		
-------------	--	--

Tables of Payload by Speed/Acceleration

High-output Setting Enabled

Please refer to the RCP6 manual regarding dedicated tables of RCP6(S)-TA4C/TA6C/TA7C with disabled high-output setting.

RCP6 Series

TA□C: Table Type (Single Guide), Motor Coupled Specification

■ RCP6/RCP6S-TA4C

Lead 16

Orientation	Horizontal						Vertical		
	Acceleration (G)								
Speed (mm/s)	0.1	0.3	0.5	0.7	1	0.1	0.3	0.5	
0	3	3	3	3	3	1	1	1	
140	3	3	3	3	3	1	1	1	
280	3	3	3	3	3	1	1	1	
420	3	3	3	3	3	1	1	1	
560	3	3	3	3	3	1	1	1	
700		3	3	3				1	
840			3	3					
980				2					
1120									
1260									

Lead 10

Orientation	Horizontal						Vertical		
	Acceleration (G)								
Speed (mm/s)	0.1	0.3	0.5	0.7	1	0.1	0.3	0.5	
0	4	4	4	4	4	2.5	2.5	2	
85	4	4	4	4	4	2.5	2.5	2	
175	4	4	4	4	4	2.5	2.5	2	
260	4	4	4	4	4	2.5	2.5	2	
350	4	4	4	4	4	2.5	2.5	2	
435		4	4	4	4		2.5	2	
525			4	4	4			2	
610				4	4			1.5	
700					4	2.5		1	
785						2.5	2		

Lead 5

Orientation	Horizontal						Vertical		
	Acceleration (G)								
Speed (mm/s)	0.1	0.3	0.5	0.7	1	0.1	0.3	0.5	
0	5	5	5	5	5	5	5	5	
40	5	5	5	5	5	5	5	5	
85	5	5	5	5	5	5	5	5	
130	5	5	5	5	5	5	5	5	
175	5	5	5	5	5	5	5	5	
215	5	5	5	5	5	5	5	5	
260	5	5	5	5	4.5	5	5	5	
305	5	5	5	5	4	4.5	4.5	4.5	
350	5	5	5	4	3.5	4	3.5	3.5	
390		5	5	4	3		2.5	2.5	

Lead 2.5

Orientation	Horizontal						Vertical		
	Acceleration (G)								
Speed (mm/s)	0.1	0.3	0.5	0.7	1	0.1	0.3	0.5	
0	5	5	5	5	5	10	9	8	
20	5	5	5	5	5	10	9	8	
40	5	5	5	5	5	10	9	8	
65	5	5	5	5	5	10	9	8	
85	5	5	5	5	5	10	9	7	
105	5	5	5	5	5	10	8	7	
130	5	5	5	5	4.5	10	8	6	
150	5	5	5	5	4	9	7	6	
175	5	5	5	4	3.5	8	7	5	
195	5	5	5	4	3	6	5	5	

■ RCP6/RCP6S-TA6C

Lead 20

Orientation	Horizontal						Vertical		
	Acceleration (G)								
Speed (mm/s)	0.1	0.3	0.5	0.7	1	0.1	0.3	0.5	
0	5	5	5	5	5	1	1	1	
160	5	5	5	5	5	1	1	1	
320	5	5	5	5	5	1	1	1	
480	5	5	5	5	5	1	1	1	
640	5	5	5	5	5	1	1	1	
800		5	4.5	4				1	
960			3.5	2					
1120				1.5					

Lead 12

Orientation	Horizontal						Vertical			
	Acceleration (G)									
Speed (mm/s)	0.1	0.3	0.5	0.7	1	0.1	0.3	0.5		
0	8	8	8	7	6	3	3	3		
80	8	8	8	7	6	3	3	3		
200	8	8	8	7	6	3	3	3		
320	8	8	8	7	6	3	3	3		
440	8	8	8	7	6	3	3	3		
500		8	8	7	6		3	3		
560			8	8	6	4		3	2.5	
680				8	7	4	2.5		2	1.5
800					5	2	1			0.5

Lead 6

Orientation	Horizontal						Vertical		
	Acceleration (G)								
Speed (mm/s)	0.1	0.3	0.5	0.7	1	0.1	0.3	0.5	
0	10	10	9	8	7	6	6	6	
40	10	10	9	8	7	6	6	6	
100	10	10	9	8	7	6	6	6	
160	10	10	9	8	7	6	6	6	
220	10	10	9	8	7	6	6	6	
250	10	10	9	8	7	6	6	5.5	
280	10	10	9	8	7	6	5.5	5	
340	10	10	9	8	7	6	4.5	4	
400	10	9	8	7	6	4.5	3.5	3	

Lead 3

Orientation	Horizontal						Vertical		
	Acceleration (G)								
Speed (mm/s)	0.1	0.3	0.5	0.7	1	0.1	0.3	0.5	
0	10	10	10	10	8	7	12	12	10
20	10	10	10	10	8	7	12	12	10
50	10	10	10	10	8	7	12	12	10
80	10	10	10	10	8	7	12	12	10
110	10	10	10	10	8	7	12	12	10
125	10	10	10	10	8	7	12	12	10
140	10	10	10	10	8	7	12	12	10
170	10	10	10	8	7	6	12	10	9
200	10	8	7	6	4	10	8	8	

■ RCP6/RCP6S-TA7C

Lead 24

Orientation	Horizontal						Vertical		
	Acceleration (G)								
Speed (mm/s)	0.1	0.3	0.5	0.7	1	0.1	0.3	0.5	
0	10	10	10	10	8	8	3	3	3
200	10	10	10	10	8	8	3	3	3
420	10	10	10	10	8	8	3	3	3
640		10	10	8	7		3	3	
860			9	7	6	3		1.5	1
1080				3.5	2				

Lead 16

Orientation	Horizontal						Vertical		
	Acceleration (G)								
Speed (mm/s)	0.1	0.3	0.5	0.7	1	0.1	0.3	0.5	
0	12	12	12	10	10	7	7	7	
140	12	12	12	10	10	7	7	7	
280	12	12	12	10	10	7	7	6	
420	12	12	12	10	8	6	5	4	
560		12	10	8	5		3	2	
700			10	6	3	2			

Lead 8

Orientation	Horizontal						Vertical		
	Acceleration (G)								
Speed (mm/s)	0.1	0.3	0.5	0.7	1	0.1	0.3	0.5	
0	15	15	15	15	15	16	14	12	
70	15	15	15	15	15	16	14	12	
140	15	15	15	15	15	16	14	10	
210	15	15	15	15	12	10	12	10	8
280	15	15	12	10	8	9	8	6	
350	12	10	8			6			
420	8								

Lead 4

Orientation	Horizontal						Vertical		
	Acceleration (G)								
Speed (mm/s)	0.1	0.3	0.5	0.7	1	0.1	0.3	0.5	
0	15	15	15	15	15	20	20	20	
35	15	15	15	15	15	20	20	20	
70	15	15	15	15	15	20	18	14	
105	15	15	15	15	15	18	16	10	
140	15	15	15	15	12	10	16	12	6
175	15	12	10					10	6
210	10							6	

RCP6 Series

TA□C□DB: Table Type (Double Guide), Motor Coupled Specification

■ RCP6/RCP6S-TA4C□DB

Lead 10

Orientation	Horizontal						Vertical		
	Acceleration (G)								
Speed (mm/s)	0.1	0.3	0.5	0.7	1	0.1	0.3	0.5	
0	8	8	8	8	6	2.5	2.5	2	
85	8	8	8	8	6	2.5	2.5	2	
175	8	8	8	8	6	2.5	2.5	2	
260	8	8	8	8	6	2.5	2.5	2	
350	8	8	8	6	6	2.5	2.5	2	
435		8	8	6	5		2.5	2	
525			8	5	4.5			2	
610				6	4.5	4		1.5	
700					4	3.5	2.5	0.5	
785						2	2		

Lead 5

Orientation	Horizontal						Vertical		
	Acceleration (G)								
Speed (mm/s)	0.1	0.3	0.5	0.7	1	0.1	0.3	0.5	
0	10	10	9	8	6	5	5	5	
40	10	10	9	8	6	5	5	5	
85	10	10	9	8	6	5	5	5	
130	10	9	9	8	6	5	5	5	
175	10	9	8	6	6	5	5	5	
215	10	9	8	6	5	5	5	5	
260	9	8	7	5	4.5	5	5	5	
305	9	8	6	5	4	4.5	4.5	4.5	
350	8	7	6	4	3.5	3.5	3	3	
390		7	6	4	3		2	2	

Lead 2.5

Orientation	Horizontal						Vertical		
	Acceleration (G)								
Speed (mm/s)	0.1	0.3	0.5	0.7	1	0.1	0.3	0.5	
0	10	10	9	8	6	10	9	8	
20	10	10	9	8	6	10	9	8	
40	10	10	9	8	6	10	9	8	
65	10	9	9	8	6	10	9	8	
85	10	9	8	6	6	10	9	7	
105	10	9	8	6	5	10	8	7	
130	9	8	7	5	4.5	10	8	6	
150	9	8	6	5	4	9	7	6	
175	8	7	6	4	3.5	8	7	5	
195	8	7	6	4	3	6	5	5	

■ RCP6/RCP6S-TA6C□DB

Lead 12

High-output Setting Enabled

Please refer to the RCP6 manual regarding dedicated tables of RCP6(S)-TA4R/TA6R/TA7R with disabled high-output setting.

RCP6 Series

TA□R: Table Type (Single Guide), Side-mounted Specification

■ RCP6/RCP6S-TA4R

Lead 16

Orientation	Horizontal						Vertical		
	Acceleration (G)								
Speed (mm/s)	0.1	0.3	0.5	0.7	1	0.1	0.3	0.5	
0	3	3	3	3	3	1	1	1	
140	3	3	3	3	3	1	1	1	
280	3	3	3	3	3	1	1	1	
420	3	3	3	3	3	1	1	1	
560	3	3	3	3	3	1	1	1	
700		3	3	3				1	
840			3	2.5					
980				1.5					
1120									
1260									

Lead 10

Orientation	Horizontal						Vertical		
	Acceleration (G)								
Speed (mm/s)	0.1	0.3	0.5	0.7	1	0.1	0.3	0.5	
0	4	4	4	4	4	2.5	2.5	2	
85	4	4	4	4	4	2.5	2.5	2	
175	4	4	4	4	4	2.5	2.5	2	
260	4	4	4	4	4	2.5	2.5	2	
350	4	4	4	4	4	2.5	2.5	2	
435		4	4	4	4		2.5	2	
525			4	4	4			2	
610				4	4			1.5	
700					4	2.5		1	
785						2.5	2		

Lead 5

Orientation	Horizontal						Vertical		
	Acceleration (G)								
Speed (mm/s)	0.1	0.3	0.5	0.7	1	0.1	0.3	0.5	
0	5	5	5	5	5	5	5	5	
40	5	5	5	5	5	5	5	5	
85	5	5	5	5	5	5	5	5	
130	5	5	5	5	5	5	5	5	
175	5	5	5	5	5	5	5	5	
215	5	5	5	5	5	5	5	5	
260	5	5	5	5	4.5	5	5	5	
305	5	5	5	5	4	4.5	4.5	4.5	
350	5	5	5	4	3.5	4	2	2	
390		5	5	4	3		1.5	1	

Lead 2.5

Orientation	Horizontal						Vertical		
	Acceleration (G)								
Speed (mm/s)	0.1	0.3	0.5	0.7	1	0.1	0.3	0.5	
0	5	5	5	5	5	10	9	8	
20	5	5	5	5	5	10	9	8	
40	5	5	5	5	5	10	9	8	
65	5	5	5	5	5	10	9	8	
85	5	5	5	5	5	10	9	7	
105	5	5	5	5	5	10	8	7	
130	5	5	5	5	4.5	10	8	6	
150	5	5	5	5	4	9	7	6	
175	5	5	5	4	3.5	7.5	7	4.5	
195	5	5	5	4	3	5	4	4	

■ RCP6/RCP6S-TA6R

Lead 20

Orientation	Horizontal						Vertical		
	Acceleration (G)								
Speed (mm/s)	0.1	0.3	0.5	0.7	1	0.1	0.3	0.5	
0	5	5	5	5	5	1	1	1	
160	5	5	5	5	5	1	1	1	
320	5	5	5	5	5	1	1	1	
480	5	5	5	5	5	1	1	1	
640	5	5	5	5	5	1	1	1	
800		5	4.5	4				1	
960			3.5	2					
1120				1.5					

Lead 12

Orientation	Horizontal						Vertical		
	Acceleration (G)								
Speed (mm/s)	0.1	0.3	0.5	0.7	1	0.1	0.3	0.5	
0	8	8	8	7	6	3	3	3	
80	8	8	8	7	6	3	3	3	
200	8	8	8	7	6	3	3	3	
320	8	8	8	7	6	3	3	3	
440	8	8	8	7	6	3	3	3	
500		8	8	7	6		3	3	
560			8	8	6	4		3	
680				8	7	4	2.5	2	
800					5	2	1		

Lead 6

Orientation	Horizontal						Vertical		
	Acceleration (G)								
Speed (mm/s)	0.1	0.3	0.5	0.7	1	0.1	0.3	0.5	
0	10	10	9	8	7	6	6	6	
40	10	10	9	8	7	6	6	6	
100	10	10	9	8	7	6	6	6	
160	10	10	9	8	7	6	6	6	
220	10	10	9	8	7	6	6	6	
250	10	10	9	8	7	6	6	5.5	
280	10	10	9	8	7	6	5.5	5	
340	10	10	9	8	7	6	4.5	4	
400	10	9	8	7	6	4.5	3.5	3	

Lead 3

Orientation	Horizontal						Vertical		
	Acceleration (G)								
Speed (mm/s)	0.1	0.3	0.5	0.7	1	0.1	0.3	0.5	
0	10	10	10	10	8	7	12	12	10
20	10	10	10	10	8	7	12	12	10
50	10	10	10	10	8	7	12	12	10
80	10	10	10	10	8	7	12	12	10
110	10	10	10	10	8	7	12	12	10
125	10	10	10	10	8	7	12	12	10
140	10	10	10	10	8	7	12	12	10
170	10	10	8	7	6	5	5	5	
200	10	8	7	6	4	4	4	4	

■ RCP6/RCP6S-TA7R

Lead 24

Orientation	Horizontal						Vertical		
	Acceleration (G)								
Speed (mm/s)	0.1	0.3	0.5	0.7	1	0.1	0.3	0.5	
0	10	10	10	8	8	3	3	3	
200	10	10	10	8	8	3	3	3	
420	10	10	10	8	8	3	3	3	
640		10	10	7	6		3	2.5	
860			7	5	4	2		1	
1080				2	0.5				

Lead 16

Orientation	Horizontal						Vertical		
	Acceleration (G)								
Speed (mm/s)	0.1	0.3	0.5	0.7	1	0.1	0.3	0.5	
0	12	12	12	10	10	7	7	7	
140	12	12	12	10	10	7	7	7	
280	12	12	12	10	10	7	7	6	
420	12	12	12	10	8	6	5	4	
560		12	10	7	5		3	1.5	
700			9	4	1				

Lead 8

Orientation	Horizontal						Vertical		
	Acceleration (G)								
Speed (mm/s)	0.1	0.3	0.5	0.7	1	0.1	0.3	0.5	
0	15	15	15	15	15	16	14	12	
70	15	15	15	15	15	16	14	12	
140	15	15	15	15	15	16	14	10	
210	15	15	15	15	12	10	12	10	
280	15	15	15	12	10	8	9	7	
350	12	10	8			4			
420	8								

Lead 4

Orientation	Horizontal						Vertical		
	Acceleration (G)								
Speed (mm/s)	0.1	0.3	0.5	0.7	1	0.1	0.3	0.5	
0	15	15	15	15	15	20	20	20	
35	15	15	15	15	15	20	20	20	
70	15	15	15	15	15	20	18	14	
105	15	15	15	15	12	18	16	10	
140	15	15	15	12	10	16	12	6	
175	15	10	4			7	4		
210	4					2			

RCP6 Series

TA□R□DB: Table Type (Double Guide), Side-mounted Specification

■ RCP6/RCP6S-TA4R□DB

Lead 10

Orientation	Horizontal						Vertical		
	Acceleration (G)								
Speed (mm/s)	0.1	0.3	0.5	0.7	1	0.1	0.3	0.5	
0	8	8	8	8	6	2.5	2.5	2	
85	8	8	8	8	6	2.5	2.5	2	
175	8	8	8	8	6	2.5	2.5	2	
260	8	8	8	8	6	2.5	2.5	2	
350	8	8	8	6	6	2.5	2.5	2	
435		8	8	6	5		2.5	2	
525			8	5	4.5			1.5	
610				5	4	3.5			
700					3.5	2.5	2		
785									

Lead 5

Orientation	Horizontal						Vertical		
	Acceleration (G)								
Speed (mm/s)	0.1	0.3	0.5	0.7	1	0.1	0.3	0.5	
0	10	10	9	8	6	5	5	5	
40	10	10	9	8	6	5	5	5	
85	10	10	9	8	6	5	5	5	
130	10	9	9	8	6	5	5	5	
175	10	9	8	6	6	5	5	5	
215	10	9	8	6	5	5	5	5	
260	9	8	7	5	4.5	5	5	5	
305	9	8	6	5	4	4	4	4	
350	8	7	6	4	3.5	3.5	3	3	
390		7	6	3.5	3		2	2	

Lead 2.5

Orientation	Horizontal						Vertical		
	Acceleration (G)								
Speed (mm/s)	0.1	0.3	0.5	0.7	1	0.1	0.3	0.5	
0	10	10	9	8	6	10	9	8	
20	10	10	9	8	6	10	9	8	
40	10	10	9	8	6	10	9	8	
65	10	9	9	8	6	10	9	8	
85	10	9	8	6	6	10	9	7	
105	10	9	8	6	5	10	8	7	
130	9	8	7	5	4.5	10	8	6	
150	9	8	6	5	4	9	7	6	
175	8	7	6	4	3.5	5	5	4.5	
195	8	7	6	4	3	4.5	4	4	

■ RCP6/RCP6S-TA6R□DB

Lead 12

Orientation	Horizontal						Vertical		
	Acceleration (G)								
Speed (mm/s)	0.1	0.3							

Selection Guideline for Allowable Load Mass

The radial cylinder has a built-in guide, so loads up to a certain level can be applied to the rod without using an external guide. Refer to the graphs below for the allowable load mass. If the allowable load will be exceeded under the required operating conditions, add an external guide.

■ Allowable Load Mass for Horizontally Mounted RCP6-RRA Series

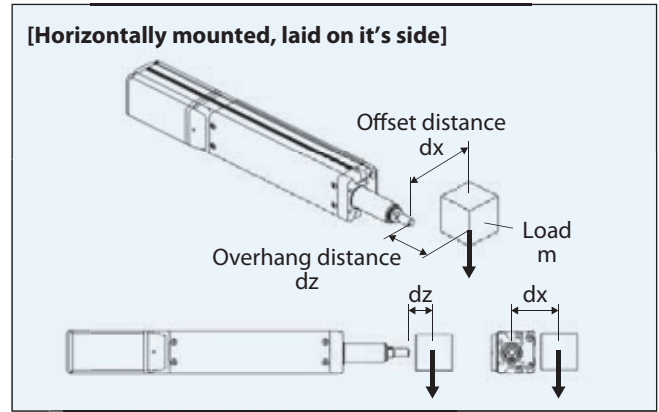
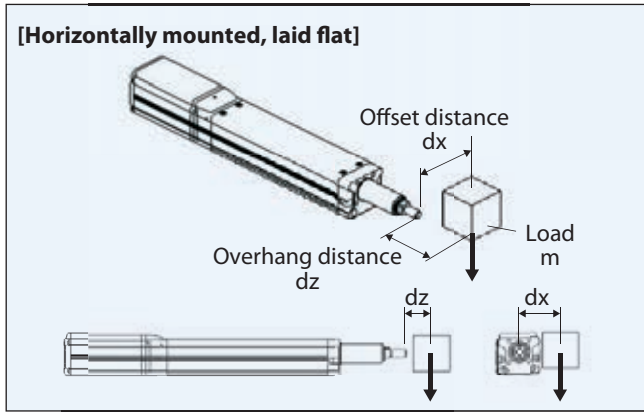

■ RCP6-RRA4/RRA6/RRA7/RRA8

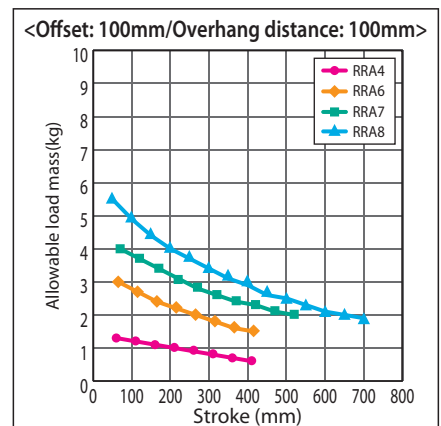
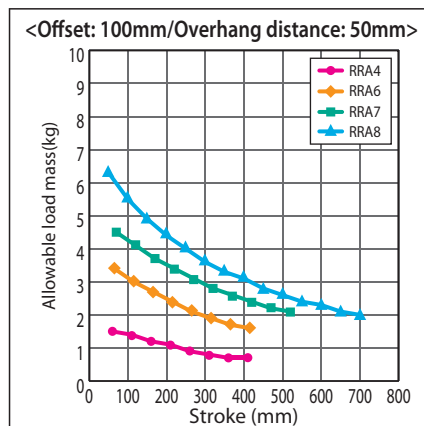
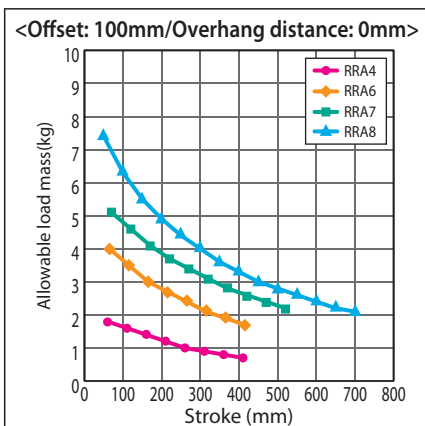
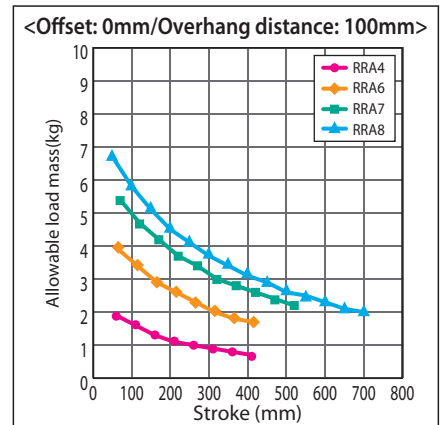
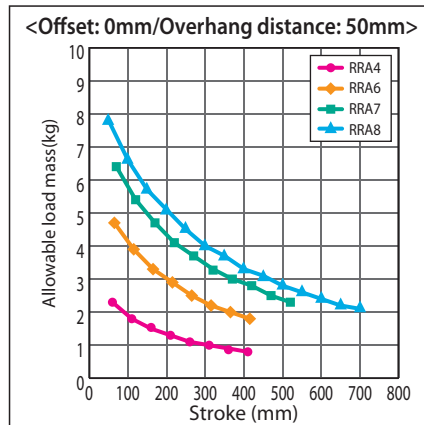
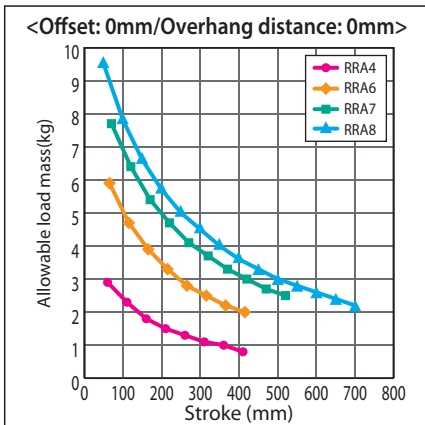

Allowable load calculation conditions.

Load mass corresponding to a product service life of 5000 km, considering moments generated by acceleration/deceleration. (Acc eleration: 1G, speed 500mm/s)

■ Allowable Load Mass for Vertically Mounted RCP6-RRA Series

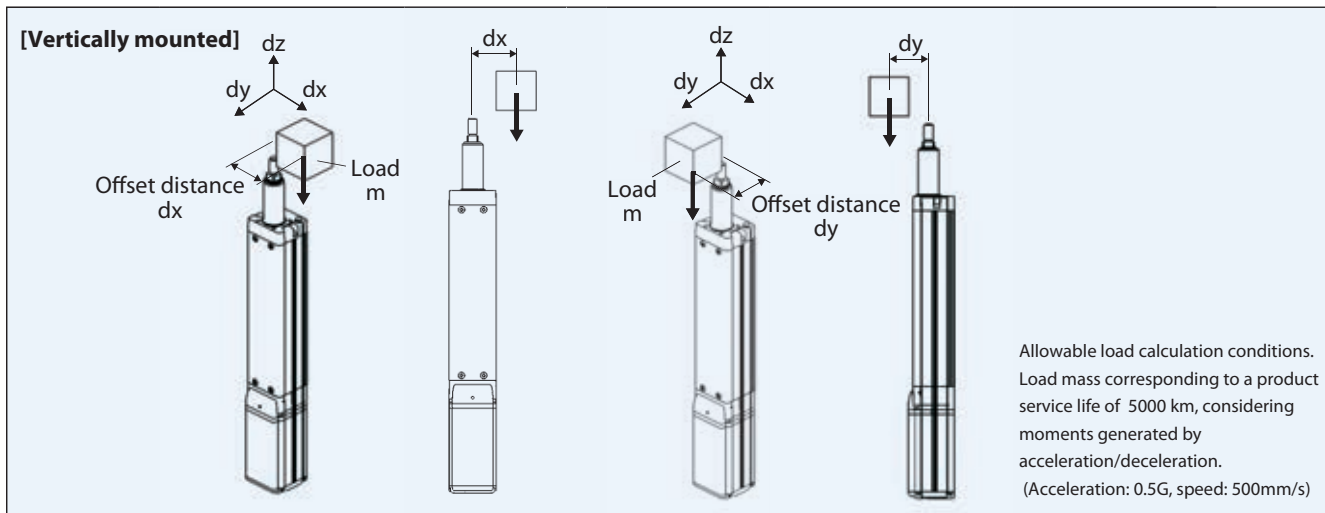

■ RCP6-RRA4

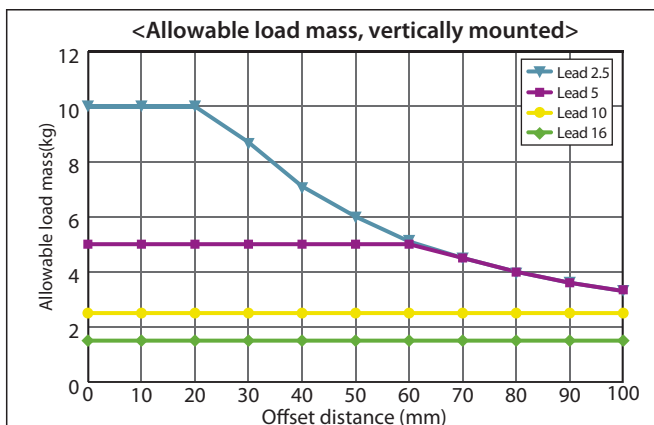

■ RCP6-RRA6

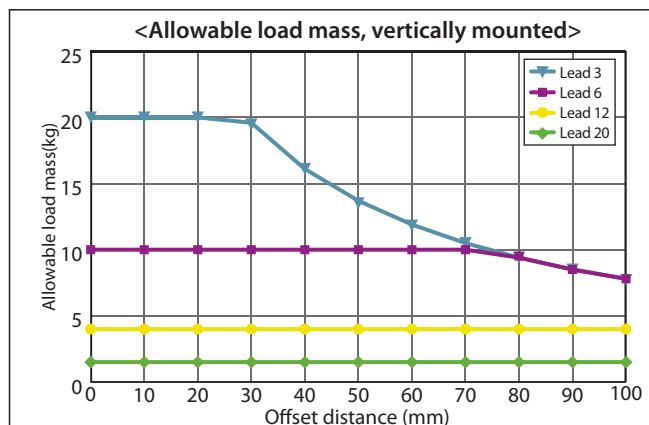

■ RCP6-RRA7

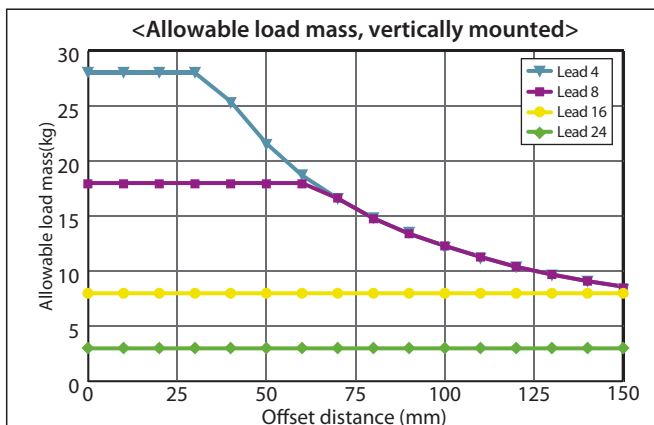

■ RCP6-RRA8

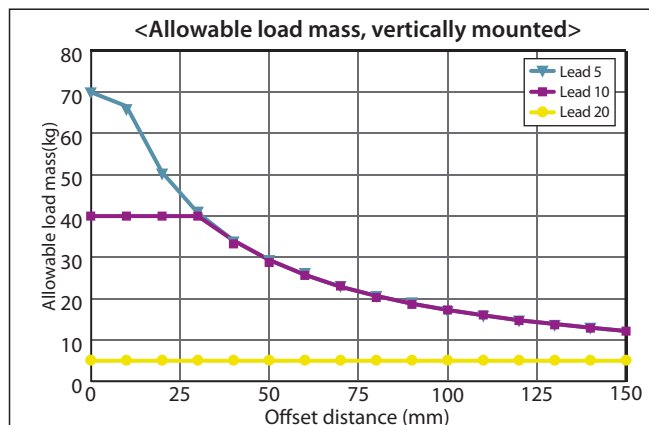

■ Allowable Load Mass for RCP6-WRA Series

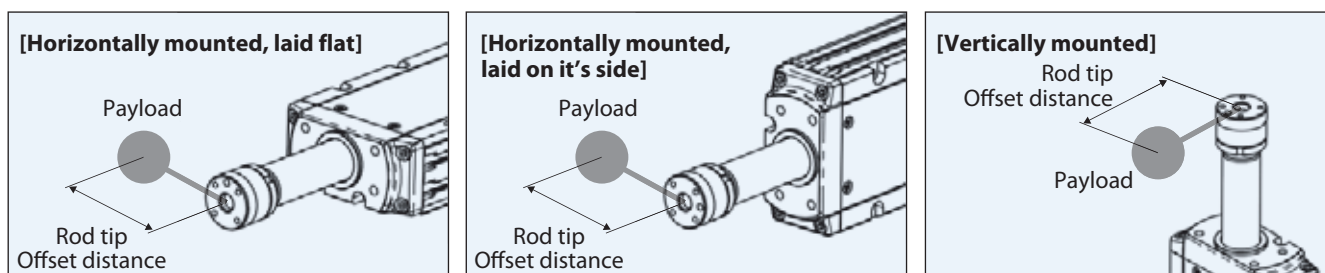

Selection Guideline for Allowable Load Mass

■ RCP6-WRA10/WRA12

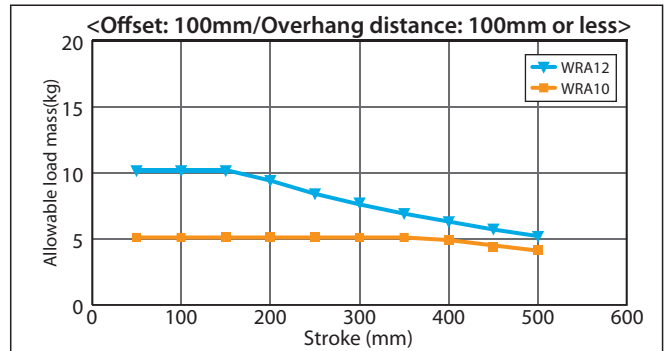
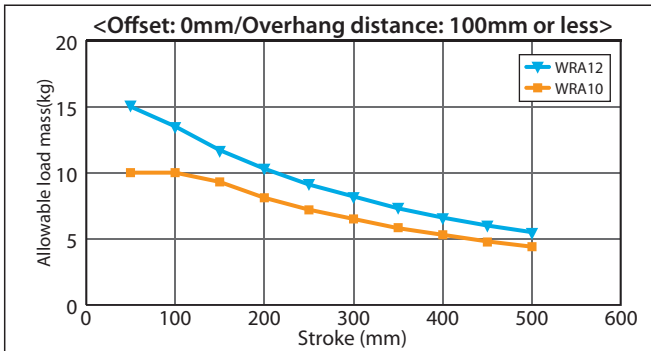

■ RCP6-WRA14/WRA16

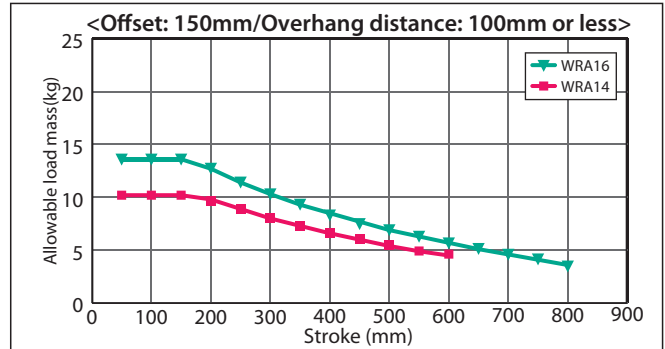
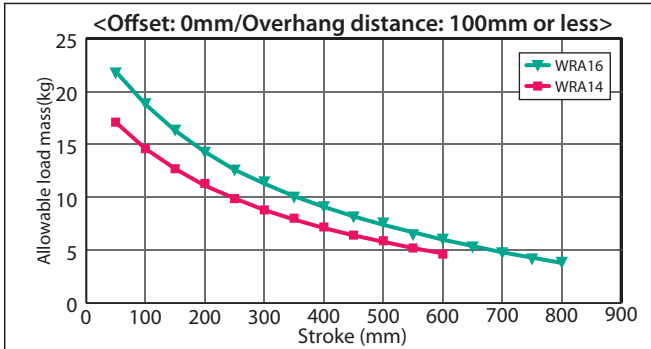

Allowable load calculation conditions: Load mass corresponding to a product service life of 5000km, considering moments generated by acceleration/deceleration. (Acceleration: 1G, speed: 500mm/s. *For WRA16 type, acceleration: 0.2G, speed: 500mm/s)

■ RCP6-WRA10

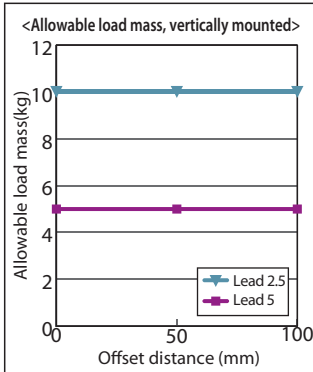

■ RCP6-WRA12

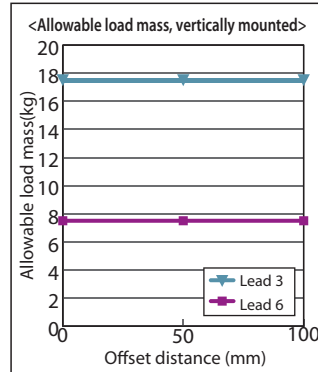

■ RCP6-WRA14

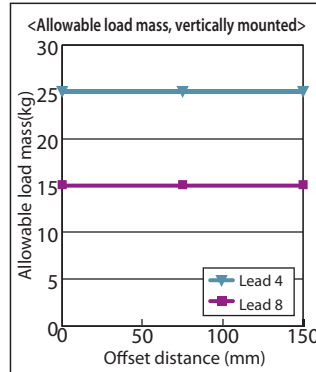

■ RCP6-WRA16

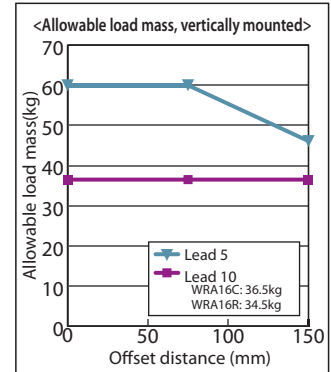

■ Allowable Load Mass for RCP6-TA Series (Table Type)

Due to the table type structure, longer stroke actuators result in lower allowable load mass.

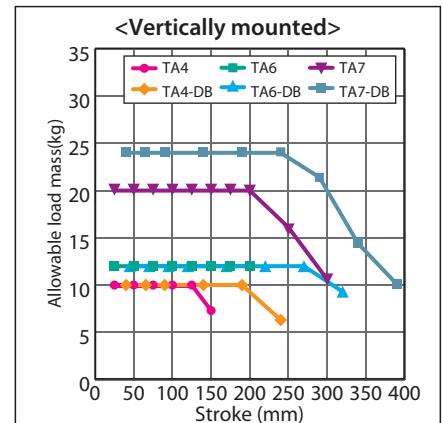
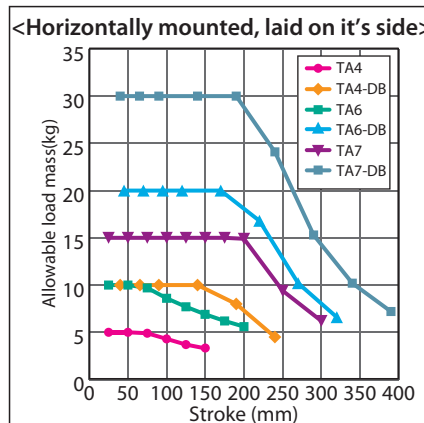
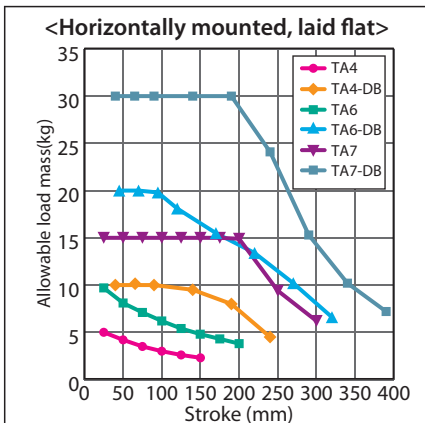

Allowable load calculation conditions: Load mass corresponding to a product service life of 5000km, considering moments generated by acceleration/deceleration (Acceleration: 0.5G, speed: 500mm/s).

Duty Cycle

Duty cycle is the percentage of the actuator's active operation time in each cycle.

Please note that the way to calculate duty cycle for the pulse motor and AC servo motor differs.

<Pulse Motor>

For pulse motor type, an actuator can be operated at 100% of its duty cycle.

RCP6S is the model that requires the duty cycle to be limited.

[Duty Cycle]

Duty cycle is the percentage of the actuator's active operation time in each cycle.

$$D = \frac{T_M}{T_M + T_R} \times 100 (\%)$$

D: Duty cycle
 T_M: Operation time
 (Includes push-motion operation)
 T_R: Stopping time

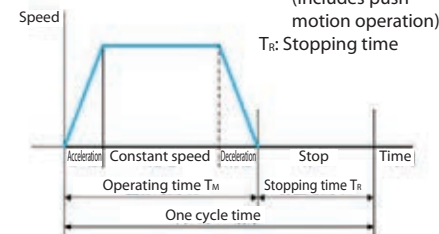

For RCP6S Series

Duty Cycle by Models

RCP6S Series	Duty Cycle
□35 pulse motor type SA4/RRA4/RA4/TA4/WSA10/WRA10 (Common to coupled motor/side-mounted motor)	100%
□42 pulse motor type SA6/RRA6/RA6/TA6/WSA12/WRA12 (Common to coupled motor/side-mounted motor)	Please see the graph below.
□56 pulse motor type SA7/RRA7/RA7/TA7/WSA14/WRA14 (Common to coupled motor/side-mounted motor)	Please see the graph below.
□56 high-thrust pulse motor type SA8/WSA16 (Common to coupled motor/side-mounted motor)	100%
□60 high-thrust pulse motor type RRA8/RA8/WRA16 (Common to coupled motor/side-mounted motor)	70%

■ Correlation diagram of ambient temperature and duty cycle for □42 pulse motor type.

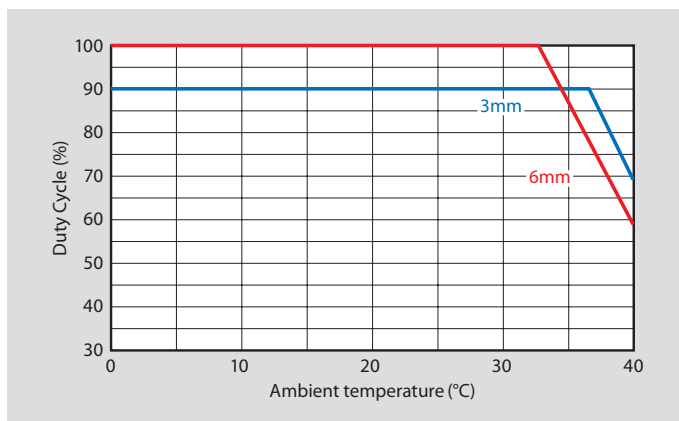

□42 pulse motor type

SA6/RRA6/RA6/TA6/WSA12/WRA12

(Common to coupled motor/side-mounted motor)

Lead	3mm	6mm	12mm/20mm
Duty Cycle Limit	90% at 37°C or below 70% or less at 40°C	100% at 33°C or below 60% or less at 40°C	100%

■ Correlation diagram of ambient temperature and duty cycle for □56 pulse motor type (Excludes the high-thrust motor)

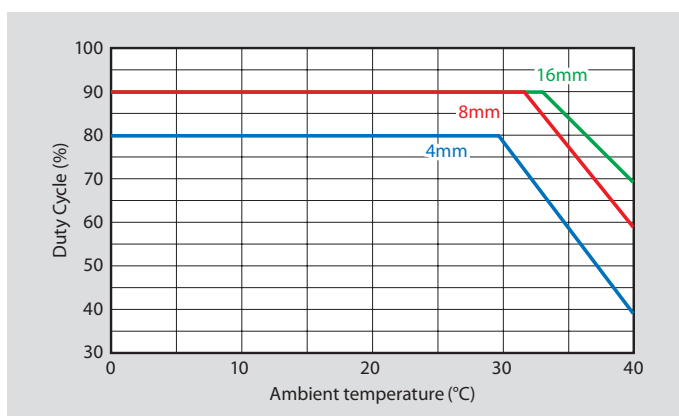

□56 pulse motor type

SA7/RRA7/RA7/TA7/WSA14/WRA14

(Common to coupled motor/side-mounted motor)

Lead	4mm	8mm	16mm	24mm
Duty Cycle Limit	80% at 30°C or below 40% or less at 40°C	90% at 32°C or below 60% or less at 40°C	90% at 33°C or below 70% or less at 40°C	100%

Selection Notes for Choosing the Double Slider

Please check the specification table and notes below when choosing the double slider.

RCP6(S) Specification Table for the Double Slider

Series	Model	Lead (mm)	Dynamic allowable moment						Overhang load length (mm)	(*1) Payload compensation mass A (kg)	(*1) Payload compensation mass B (kg)	(*1) Payload compensation speed (mm/s)	Slider length (mm)	Min. stroke when double slider is chosen (mm)
			Standard rated service life (km)	Slider span (mm)		Ma direction (N·m)	Mb direction (N·m)	Mc direction (N·m)						
				Actual slider span	Slider cover span				Ma direct. Mb, Mc direction					
RCP6(S)	SA4C(R)	10	5000	60	24	44.6	63.6	15.7	420	0.6	2	350	76	150
		5										215		
		2.5										105		
	SA6C(R)	12	5000	90	40	106	152	40	630	1.2	2	320	110	200
		6										280		
		3										140		
	SA7C(R)	16	5000	70	20	285	285	145	810	1.7	5	280	130	200
		8										140		
		4										70		
	SA8C(R)	20	5000	120	35	565	565	237	1200	7 (*2)	—	—	165	250
		10										—		
		5										—		

[Table of Unavailable Lead Model Types with Double Slider]

Series	Model	Lead (mm)	Double slider option cannot be chosen (*1)	
			Horizontal mount	Vertical mount
RCP6(S)	SA4C(R)	16	•	•
		10		•
	SA6C(R)	20	•	•
		12		•
	SA7C(R)	24	•	•
		16		•
	SA8C(R)	30	•	•
		20		•

[Diagram for Double Slider Span]

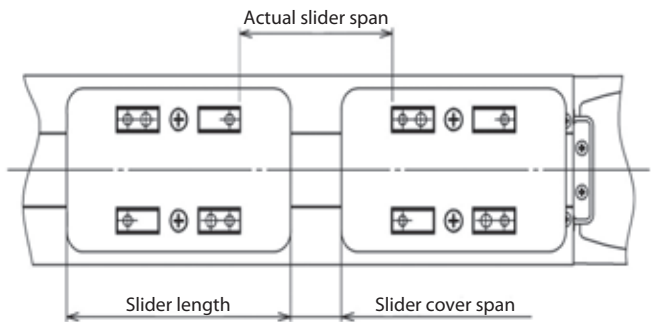

- (*1) For double slider specification (except RCP6-SA8):
 For slower speed than Payload Compensation Speed, the maximum payload is the payload for single slider minus Payload Compensation Mass A.
 For higher speed than Payload Compensation Speed, the maximum payload is the payload for single slider minus Payload Compensation Mass B.
 For finding the payload of single slider, consider maximum speed of the nominal stroke, not the effective stroke.
- (*2) For double slider specification of RCP6-SA8,
 its maximum payload is the payload of single axis minus Payload Compensation Mass A in all the speed range.
 For finding the payload of single slider, consider maximum speed of the nominal stroke, not the effective stroke.

(Note)

- For determining the payload of double slider, use the value in above table and [Table of payload by speed/acceleration] (p.115~). Based on the payload determined, check its maximum speed. Refer to the RCP6 manual for the details.
- Double slider cannot be chosen for some of lead sizes. Refer to [Table of Unavailable Lead Model Types with Double Slider].
- In case both double slider specification and non-motor end specification are selected, make sure to perform a homing by customer once the drive slider and free slider are linked.

PCON-CB/CFB

Position Controller for RCP6/RCP5/
RCP4 (PowerCon Applicable) /RCP3/RCP2



Features

1 High-resolution battery-less absolute encoder compatible

The RCP6 equipped with a high-resolution battery-less absolute encoder is supported. Since no battery is needed to retain position data, less space is required in the control panel, which in turn leads to lower cost of your equipment. The resolution is increased from 800 pulses/rev to 8192 pulses/rev.



2 PowerCon Equipped

PowerCon (high-output driver), which can enable the pulse motor to perform at its maximum capacity, is now installed on a small controller. By using PowerCon, the output of the pulse motor is increased by 50%. It contributes to cycle time reduction and productivity improvement.

3 Collision Detection Function Equipped

This function stops the operation immediately when the actuator comes into contact with an object. The actuator stops without crashing, so that damage to the actuator can be minimized.

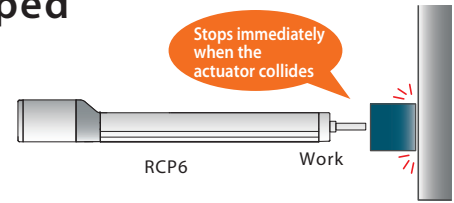

4 Enhanced Monitor Functions

The PC compatible software can display information about the actuator and controller in operation as waveforms. *Information that can be displayed: Command current value, current speed/position, and PIO signals (start, positioning completion, alarm, etc.) Using the trigger function, the end user can specify a particular moment, either a change in PIO signals or a designated moment during the actuator's operation time, to begin displaying the waveforms.

Monitor function screen (example)

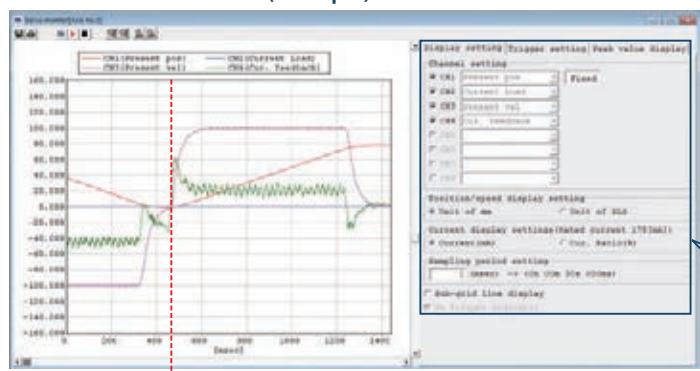

Signal: CSTR (start) turned ON

Display settings

* Items to be monitored can be selected.

Trigger settings

* Data acquiring starts from time of change of selected items.

List of Models

Model number		PCON-CB/CGB, CFB/CGFB								
External view										
I/O type	Positioner type	Pulse-train type	Field network type							
			DeviceNet	CC-Link	PROFIBUS-DP	CompoNet	EtherCAT	EtherNet/IP	PROFINET IO	
I/O type model number		NP/PN	PLN/PLP	DV	CC	PR	CN	EC	EP	PRT
PCON-CB/CGB	Battery-less absolute specification Incremental specification	○	○	○	○	○	○	○	○	○
	Simple absolute spec.	With absolute battery	○	—	○	○	○	○	○	○
		With absolute battery unit	○	—	○	○	○	○	○	○
		Without absolute battery	○	—	○	○	○	○	○	○
PCON-CFB/CGFB	Battery-less absolute specification Incremental specification	○	○	○	○	○	○	○	○	

Model Specification Items

< Controller >

PCON — [] — [] — [] — [] — [] — 0 — [] — []

Series Type Motor Type Encoder Type I/O Type I/O Cable Length Power Supply Voltage Simple Absolute Specification Controller Mounting Specification

CB	Standard	WAI Battery-less absolute specification Incremental specification SA Simple absolute specification	NP PIO (NPN) PLN Pulse train (NPN) PN PIO (PNP) PLP Pulse train (PNP) DV DeviceNet CC CC-Link PR PROFIBUS-DP CN CompoNet EC EtherCAT EP EtherNet/IP PRT PROFINET IO	20□ Pulse motor 20SP 20□ High-thrust pulse motor 28P 28□ Pulse motor 28SP 28□ High-thrust pulse motor 35P 35□ Pulse motor 42P 42□ Pulse motor 42SP 42□ High-thrust pulse motor 56P 56□ Pulse motor 56SP 56□ High-thrust pulse motor 60P 60□ High-thrust pulse motor 86P 86□ High-thrust pulse motor	0 No cable 2 2m 3 3m 5 5m	0 24VDC	(Blank) Battery-less absolute specification Incremental specification AB Simple absolute specification (With absolute battery. No battery unit included) ABU Simple absolute specification (With absolute battery and battery unit) ABUN Simple absolute specification (Without absolute battery and battery unit)	(Blank) Screw mounting specification DN DIN rail mounting specification
CGB	Safety category compliant type							
CFB	56SP/60P/86P motor-compatible type							
CGFB	Safety category compliant, 56SP/60P/86P motor-compliant type							

(e.g.) 20P : For 20□ pulse motor

Note
 In general, the model number for motor type will be the same as the model number of the actuator's motor, but there is a few exceptions which the model number of controller and actuator do not match. Below is the list of those models. Please be careful when these item(s) are selected.
 <28SP applicable actuator> • Controller Motor Type [28SP] RCP2-RA3C

* When a field network specification is selected, the I/O cable length is "0".

* PCON-CFB/CGFB does not support a simple absolute specification.

* The mounting type (screw or DIN rail) of the absolute battery unit and the controller must be the same.

System Configuration

PowerCON150 <PCON-CB/CGB>

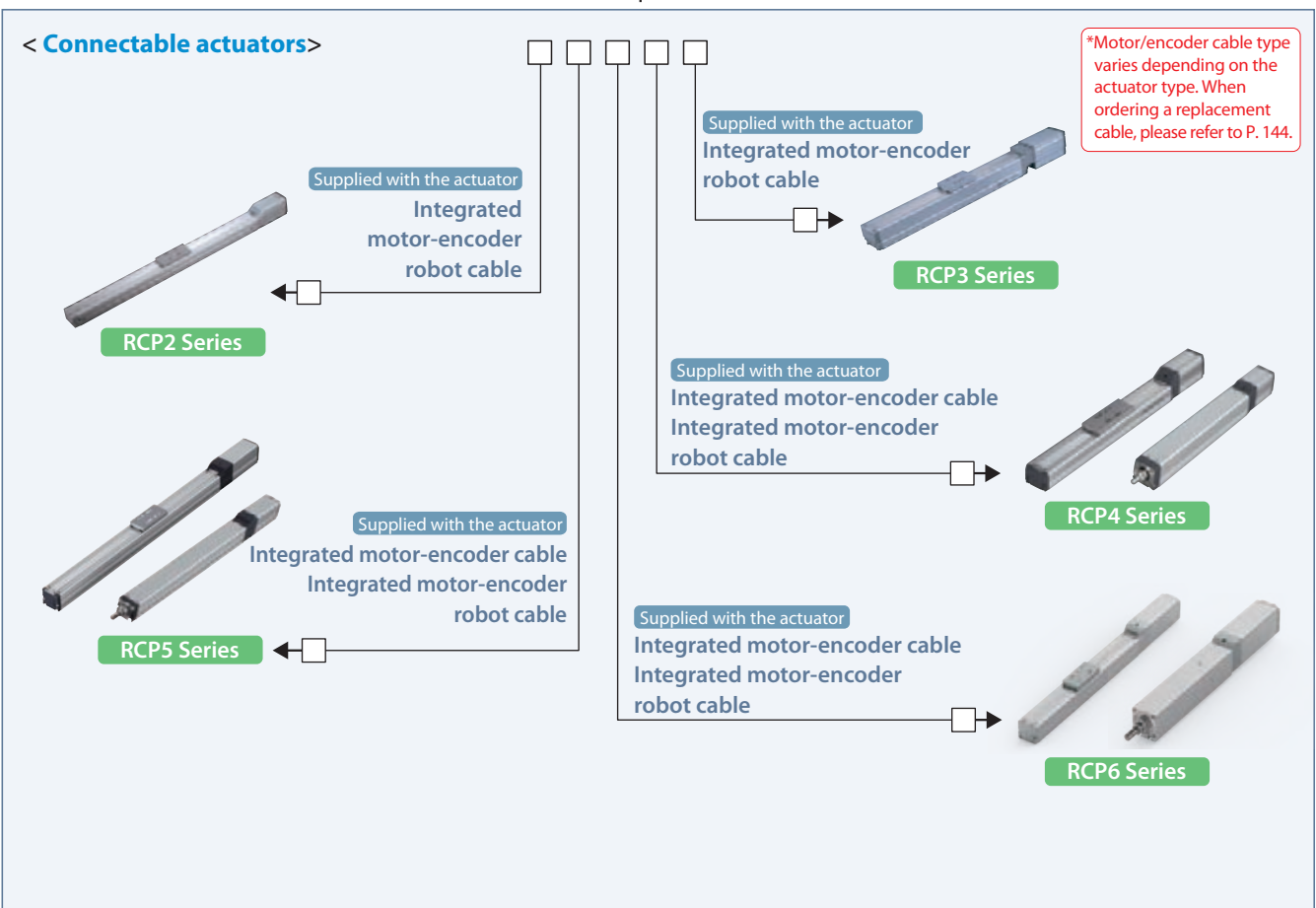
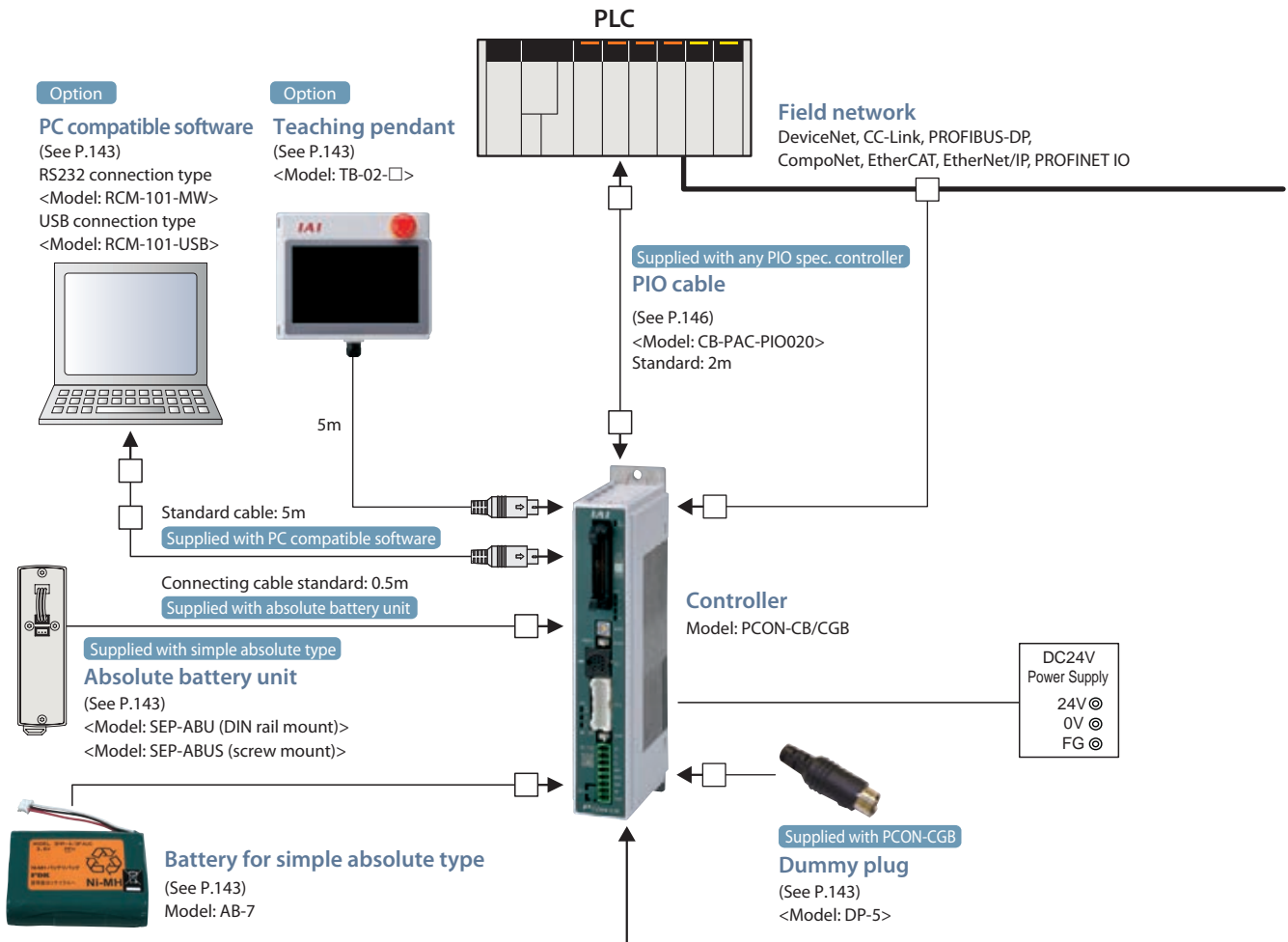

System Configuration

56SP/60P/86P Motor Compatible <PCON-CFB/CGFB>

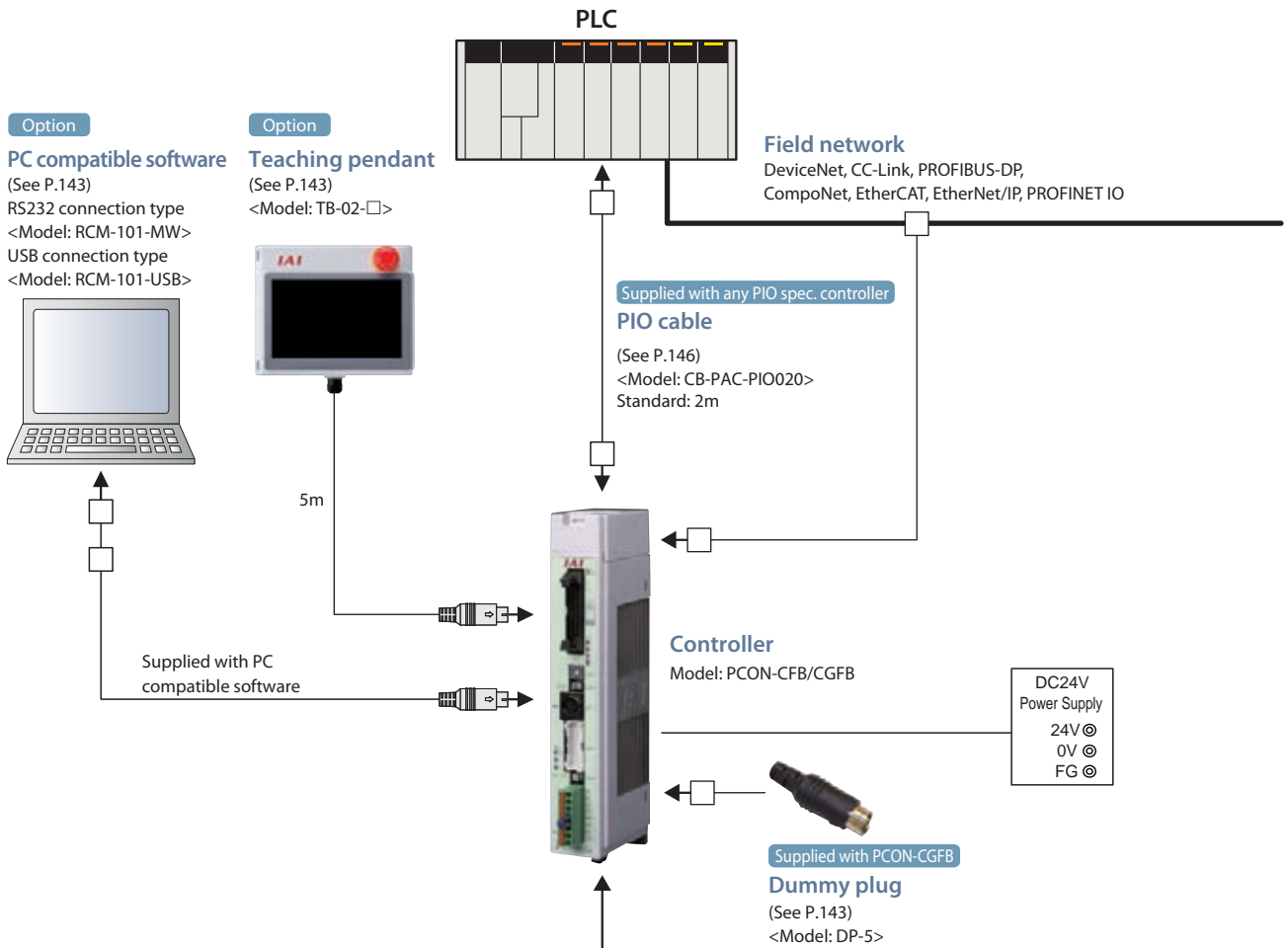

< Connectable actuators >

Supplied with the actuator

Integrated motor-encoder cable
Integrated motor-encoder robot cable

RCP2 Series



Supplied with the actuator

Integrated motor-encoder cable
Integrated motor-encoder robot cable

RCP4 Series



Supplied with the actuator

Integrated motor-encoder cable
Integrated motor-encoder robot cable

RCP5 Series



Supplied with the actuator

Integrated motor-encoder cable
Integrated motor-encoder robot cable

RCP6 Series



PIO I/O Interface

Input part External input specification

Item	Specification
Input voltage	24VDC ±10%
Input current	5mA, 1 circuit
ON/OFF voltage	ON voltage, 18VDC min. OFF voltage, 6VDC max.

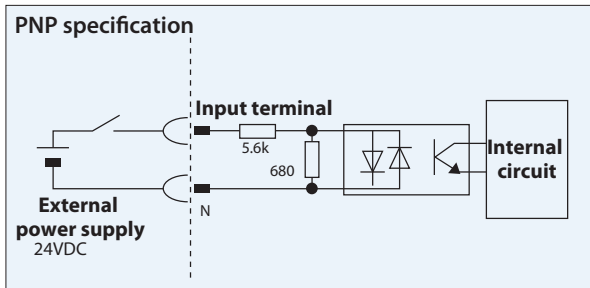
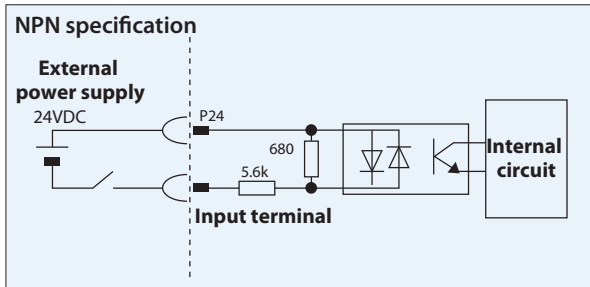

Output part External output specification

Item	Specification
Load voltage	24VDC
Maximum load current	50mA, 1 circuit
Leak current	2mA max. /point

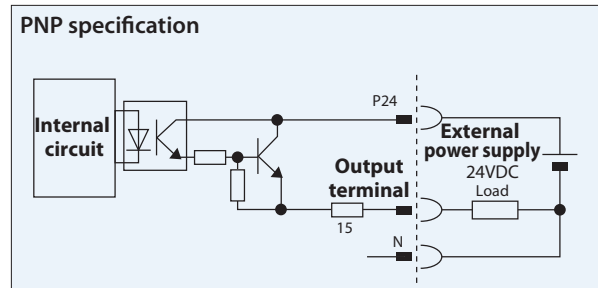
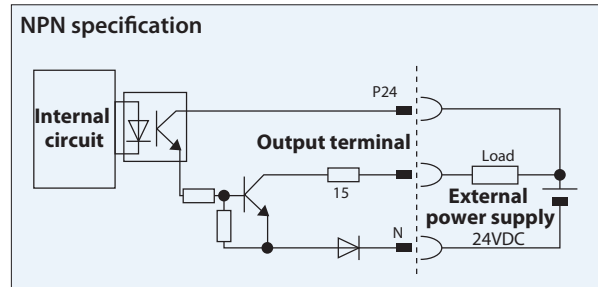

Types of PIO Patterns (Control Patterns)

This controller has eight different control methods.

Please select the PIO pattern that best suits your application in Parameter No.25, "PIO Pattern Selection".

Type	Set value of parameter No.25	Mode	Overview
PIO Pattern 0	0 (Factory setting)	Positioning mode (Standard type)	<ul style="list-style-type: none"> Number of positioning points: 64 points Position number command: Binary Coded Decimal (BCD) Zone signal output^{*1}: 1 point Position zone signal output^{*2}: 1 point
PIO Pattern 1	1	Teaching mode (Teaching type)	<ul style="list-style-type: none"> Number of positioning points: 64 points Position number command; Binary Coded Decimal (BCD) Position zone signal output^{*2}: 1 point Jog (inching) operation using PIO signals is supported. Current position data can be written to the position table using PIO signals.
PIO Pattern 2	2	256-point mode (256 positioning points)	<ul style="list-style-type: none"> Number of positioning points: 256 points Position number command: Binary Coded Decimal (BCD) Position zone signal output^{*2}: 1 point
PIO Pattern 3	3	512-point mode (512 positioning points)	<ul style="list-style-type: none"> Number of positioning points: 512 points Position number command: Binary Coded Decimal (BCD) No zone signal output
PIO Pattern 4	4	Solenoid valve mode 1 (7-point type)	<ul style="list-style-type: none"> Number of positioning points: 7 points Zone signal output^{*1}: 1 point Position number command: Individual number signal ON Position zone signal output^{*2}: 1 point
PIO Pattern 5	5	Solenoid valve mode 2 (3-point type)	<ul style="list-style-type: none"> Number of positioning points: 3 points Position number command: Individual number signal ON Completion signal: A signal equivalent to a LS (limit switch) signal can be output. Zone signal output^{*1}: 1 point Position zone signal output^{*2}: 1 point
PIO Pattern 6 (Note 1)	6	Pulse-train control mode for incremental	<ul style="list-style-type: none"> Differential pulse input (200 kpps max.) Home return function Zone signal output^{*1}: 2 points No feedback pulse output
PIO Pattern 7 (Note 1)	7	Pulse-train control mode for absolute	<ul style="list-style-type: none"> Reference point setting (1 point) Home return function Differential pulse input (200 kpps max.) No feedback pulse output Zone signal output^{*1}: 2 points

*1 Zone signal output: Please set the desired zone range in Parameter No.1/2 or 23/24, and it will remain effective once home return is completed.

*2 Position zone signal output: This command function relates to the position number. Set the desired zone range in the position table, and this function will only become enabled when the corresponding position is specified; it will be disabled for all other position commands.

(Note 1) Pulse train control mode is available only the pulse train control type is specified (PCON-CB-PLN and PLP) at the time of purchase.

PIO Patterns and Signal Assignments

The table below lists the signal assignments for the I/O flat cable under different PIO patterns. Connect an external device (such as a PLC) according to this table.

Pin No.	Category	PIO function	Parameter No.25, "PIO Pattern Selection"					
			0	1	2	3	4	5
			Positioning mode	Teaching mode	256-point mode	512-point mode	Solenoid valve mode 1	Solenoid valve mode 2
	Input	Number of positioning points	64 points	64 points	256 points	512 points	7 points	3 points
		Home return signal	○	○	○	○	○	—
		Jog signal	—	○	—	—	—	—
		Teaching signal (writing of current position)	—	○	—	—	—	—
	Output	Brake release	○	—	○	○	○	○
		Moving signal	○	○	—	—	—	—
		Zone signal	○	△ (Note 1)	△ (Note 1)	—	○	○
		Position zone signal	○	○	○	—	○	○
1A	24V	P24						
2A	24V	P24						
3A	Pulse Input							-
4A								-
5A	Input	IN0	PC1	PC1	PC1	PC1	ST0	ST0
6A		IN1	PC2	PC2	PC2	PC2	ST1	ST1(JOG+)
7A		IN2	PC4	PC4	PC4	PC4	ST2	ST2 (Non-Functional)
8A		IN3	PC8	PC8	PC8	PC8	ST3	-
9A		IN4	PC16	PC16	PC16	PC16	ST4	-
10A		IN5	PC32	PC32	PC32	PC32	ST5	-
11A		IN6	-	MODE	PC64	PC64	ST6	-
12A		IN7	-	JISL	PC128	PC128	-	-
13A		IN8	-	JOG+	-	PC256	-	-
14A		IN9	BKRL	JOG-	BKRL	BKRL	BKRL	BKRL
15A		IN10	RMOD	RMOD	RMOD	RMOD	RMOD	RMOD
16A		IN11	HOME	HOME	HOME	HOME	HOME	-
17A		IN12	*STP	*STP	*STP	*STP	*STP	-
18A		IN13	CSTR	CSTR/PWRT	CSTR	CSTR	-	-
19A		IN14	RES	RES	RES	RES	RES	RES
20A	IN15	SON	SON	SON	SON	SON	SON	
1B	Output	OUT0	PM1 (ALM1)	PM1 (ALM1)	PM1 (ALM1)	PM1 (ALM1)	PE0	LSO
2B		OUT1	PM2 (ALM2)	PM2 (ALM2)	PM2 (ALM2)	PM2 (ALM2)	PE1	LS1(TRQS)
3B		OUT2	PM4 (ALM4)	PM4 (ALM4)	PM4 (ALM4)	PM4 (ALM4)	PE2	LS2 (Note2)
4B		OUT3	PM8 (ALM8)	PM8 (ALM8)	PM8 (ALM8)	PM8 (ALM8)	PE3	-
5B		OUT4	PM16	PM16	PM16	PM16	PE4	-
6B		OUT5	PM32	PM32	PM32	PM32	PE5	-
7B		OUT6	MOVE	MOVE	PM64	PM64	PE6	-
8B		OUT7	ZONE1	MODES	PM128	PM128	ZONE1	ZONE1
9B		OUT8	PZONE/ZONE2	PZONE/ZONE1	PZONE/ZONE1	PM256	PZONE/ZONE2	PZONE/ZONE2
10B		OUT9	RMDS	RMDS	RMDS	RMDS	RMDS	RMDS
11B		OUT10	HEND	HEND	HEND	HEND	HEND	HEND
12B		OUT11	PEND	PEND/WEND	PEND	PEND	PEND	-
13B		OUT12	SV	SV	SV	SV	SV	SV
14B		OUT13	*EMGS	*EMGS	*EMGS	*EMGS	*EMGS	*EMGS
15B		OUT14	*ALM	*ALM	*ALM	*ALM	*ALM	*ALM
16B	OUT15	LOAD/TRQS *ALML	*ALML	LOAD/TRQS *ALML	LOAD/TRQS *ALML	LOAD/TRQS *ALML	*ALML	
17B	Pulse Input							-
18B								-
19B	0V							N
20B	0V							N

(Note) In the table above, asterisk * symbol accompanying each code indicates a negative logic signal. PM1~PM8 are alarm binary code output signals that are used when an alarm generates.

(Note 1) In all PIO patterns other than 3, this signal can be switched with PZONE by setting Parameter No. 149 accordingly.

(Note 2) The setting will not become effective until the home return is completed.

Reference) Negative logic signal

Signals denoted by * are negative logic signals. Negative logic input signals are processed when turned OFF. Negative logic output signals normally remain ON while the power is supplied, and turn OFF when the signal is output.

Pulse-train Control Circuit

■ Host Unit = Differential Type

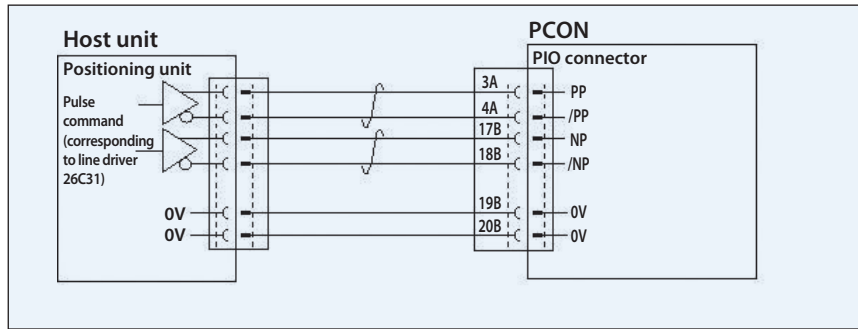

■ Host Unit = Open Collector Type

The AK-04 (optional) is needed to input pulses.

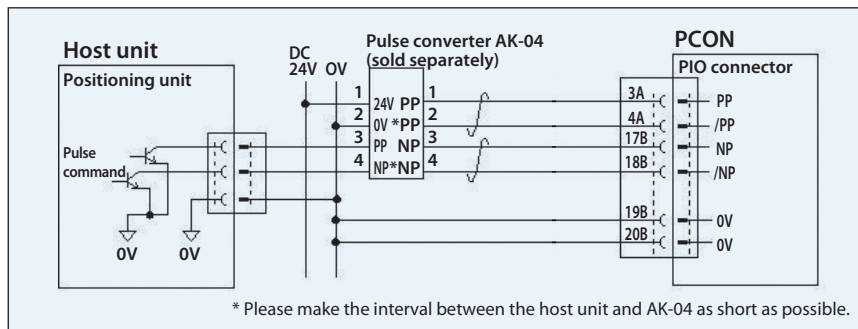

⚠ Caution: Use the same power supply for open collector input/output to/from the host and for the AK-04.

Command Pulse Input Patterns

		Command pulse-train pattern	Input terminal	Forward	Reverse	
Negative logic	Forward pulse-train		PP-/PP			
	Reverse pulse-train		NP-/NP			
	A forward pulse-train indicates the amount of motor rotation in the forward direction, while a reverse pulse-train indicates the amount of motor rotation in the reverse direction.					
	Pulse-train		PP-/PP			
	Sign		NP-/NP	Low	High	
The command pulses indicate the amount of motor rotation, while the sign indicates the rotating direction.						
Positive logic	Phase A/B pulse-train		PP-/PP			
			NP-/NP			
	Command phases A and B having a 90° phase difference (multiplier is 4) indicate the amount of rotation and the rotating direction.					
	Forward pulse-train		PP-/PP			
	Reverse pulse-train		NP-/NP			
Positive logic	Pulse-train		PP-/PP			
	Sign		NP-/NP	High	Low	
	Phase A/B pulse-train		PP-/PP			
			NP-/NP			

I/O Signals in Pulse-train Control Mode

The table below lists the signal assignments for the flat cable in the pulse-train control mode. Connect an external device (such as PLC) according to this table.

Pin number	Category	I/O number	Signal abbreviation	Signal name	Parameter No.25, "PIO pattern 6/7"
1A	24V		P24	Power supply	I/O power supply +24V
2A	24V		P24	Power supply	I/O power supply +24V
3A	Pulse Input		PP	Differential pulse-train input (+)	Differential pulses are input from the host. Up to 200kpps can be input.
4A			/PP	Differential pulse-train input (-)	
5A	Input	IN0	SON	Servo ON	The servo is ON while this signal is ON, and OFF while the signal is OFF.
6A		IN1	RES	Reset	Present alarms are reset when this signal is turned ON.
7A		IN2	HOME	Home return	Home return operation is performed when this signal is turned ON.
8A		IN3	TL	Torque limit selection	When this signal is turned ON, the motor torque is limited to the value set by the parameter.
9A		IN4	CSTP	Forced stop	The actuator is forcibly stopped when this signal has remained ON for 16ms or more. The actuator decelerates to a stop at the torque set in the controller and the servo turns OFF.
10A		IN5	DCLR	Deviation counter clear	This signal clears the deviation counter.
11A		IN6	BKRL	Forced brake release	The brake is forcibly released.
12A		IN7	RMOD	Operation mode switching	The operation mode can be switched when the MODE switch on the controller is set to AUTO. (AUTO when this signal is OFF, and to MANU when the signal is ON.)
13A		IN8	RSTR*1	Reference position movement command	When this signal turns on, the actuator moves to the reference position set in parameter No.167. *1: Used only in PIO Pattern 7.
14A		IN9	NC	-	Not used
15A		IN10	NC	-	Not used
16A		IN11	NC	-	Not used
17A		IN12	NC	-	Not used
18A		IN13	NC	-	Not used
19A		IN14	NC	-	Not used
20A	IN15	NC	-	Not used	
1B	Output	OUT0	PWR	System ready	This signal turns ON when the controller becomes ready after the main power supply has been turned on.
2B		OUT1	SV	Servo ON status	This signal turns ON when the servo is ON.
3B		OUT2	INP	Positioning complete	This signal turns ON when the amount of remaining travel pulses in the deviation counter falls within the in-position band.
4B		OUT3	HEND	Home return complete	This signal turns ON upon completion of home return.
5B		OUT4	TLR	Torque limited	This signal turns ON upon reaching the torque limit while the torque is limited.
6B		OUT5	#ALM	Controller alarm status	This signal turns ON when the controller is normal, and turns OFF when an alarm generates.
7B		OUT6	#EMGS	Emergency stop status	This signal turns ON when the emergency stop of the controller is cancelled, and turns OFF when an emergency stop is actuated.
8B		OUT7	RMD5	Operation mode status	The operation mode status is output. This signal turns ON when the controller is in the manual mode.
9B		OUT8	ALM1	Alarm code output signal	An alarm code is output when an alarm generates. For details, refer to the operation manual.
10B		OUT9	ALM2		
11B		OUT10	ALM4		
12B		OUT11	ALM8		
13B		OUT12	#ALML		
14B		OUT13	REND*1	Reference position movement complete	This signal turns ON when movement to the reference point set in parameter No. 167 is completed. *1: Used only in PIO Pattern 7.
15B		OUT14	ZONE1	Zone signal 1	This signal turns ON when the current position of the actuator falls within the parameter-set range.
16B	OUT15	ZONE2	Zone signal 2		
17B	Pulse Input		NP	Differential pulse-train input (+)	Differential pulses are input from the host. Up to 200kpps can be input.
18B			/NP	Differential pulse-train input (-)	
19B	0V		N	Power supply	I/O power supply 0V
20B	0V		N	Power supply	I/O power supply 0V

Note) # indicates a negative logic signal. Negative logic signals are normally ON while the power is supplied, and turn OFF when the signal is output.

Field Network Specification: Explanation of Operation Modes

If the PCON-CB is controlled via a field network, you can select one of the following five modes to operate the actuator. Please note that the data areas required on the PLC side will vary depending on the mode.

■ Mode Description

	Mode	Description
0	Remote I/O mode	Similarly to the PIO specification, this mode operates by directing bytes to ON/OFF via a network. The number of positioning points and functions will vary depending on the operation patterns (PIO patterns) set by the controller's parameters.
1	Position/simple direct value mode	The target position value is directly input, while all other operational conditions (speed, acceleration, etc) are set by indicating the position number corresponding to the desired operating conditions from the position data table.
2	Half direct value mode	The actuator is operated by directly inputting values for speed, acceleration rate and push current, as well as the target position.
3	Full direct value mode	The actuator is operated by directly inputting values for the target position, speed, acceleration rate and push current, etc. In addition, you are able to read the current position, current speed, and the specified current, etc.
4	Remote I/O mode 2	This mode is the same as the remote I/O mode above, with the added functionality of reading current position and the command motor current.

■ Required Data Size for Each Network

		DeviceNet	CC-Link	PROFIBUS-DP	CompoNet	EtherCAT	EtherNet/IP	PROFINET IO
0	Remote I/O mode	2 bytes	1 station	2 bytes	2 bytes	2 bytes	2 bytes	2 bytes
1	Position/simple direct value mode	8 bytes	1 station	8 bytes	8 bytes	8 bytes	8 bytes	8 bytes
2	Half direct value mode	16 bytes	2 stations	16 bytes	16 bytes	16 bytes	16 bytes	16 bytes
3	Full direct value mode	32 bytes	4 stations	32 bytes	32 bytes	32 bytes	32 bytes	32 bytes
4	Remote I/O mode 2	12 bytes	1 station	12 bytes	12 bytes	12 bytes	12 bytes	12 bytes

■ List of Functions by Operation Mode

	Remote I/O mode	Position/simple direct value mode	Half direct value mode	Full direct value mode	Remote I/O mode 2
Number of positioning points	512 points	768 points	Unlimited	Unlimited	512 points
Operation by direct position data input	—	○	○	○	—
Direct speed/acceleration input	—	—	○	○	—
Push-motion operation	○	○	○	○	○
Current position read	—	○	○	○	○
Current speed read	—	—	○	○	—
Operation by position number input	○	○	—	—	○
Completed position number read	○	○	—	—	○

* ○ indicates that the operation is supported, and — indicates that it is not supported.

External Dimensions

<PCON-CB/CGB>

Battery-less Absolute/Incremental Specifications Screw Mounting Spec.

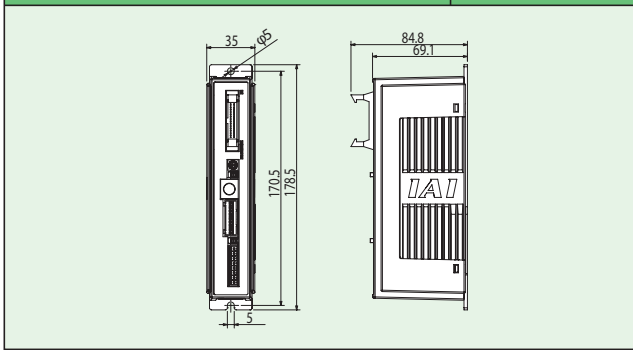

Battery-less Absolute/Incremental Specifications DIN Rail Mounting Spec.

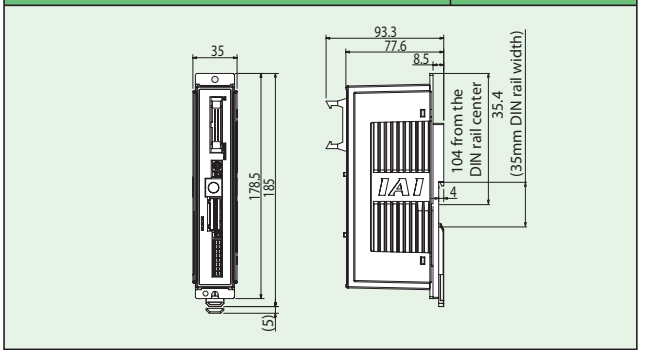

Simple Absolute Specification w/ Absolute Battery Screw Mounting Spec.

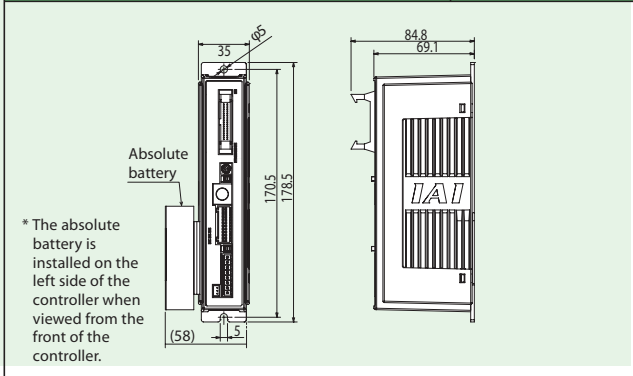

Simple Absolute Specification w/ Absolute Battery DIN Rail Mounting Spec.

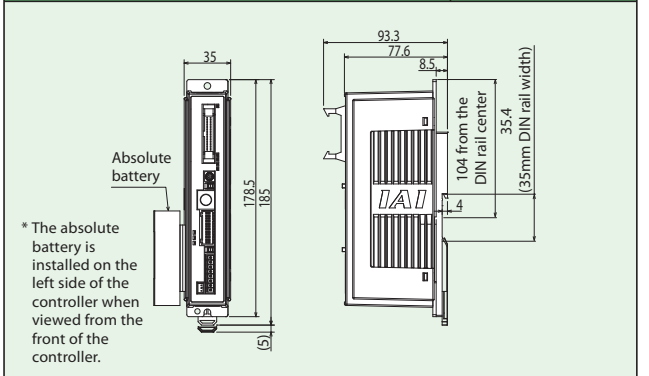

Simple Absolute Specification w/ Absolute Battery Unit Screw Mounting Spec.

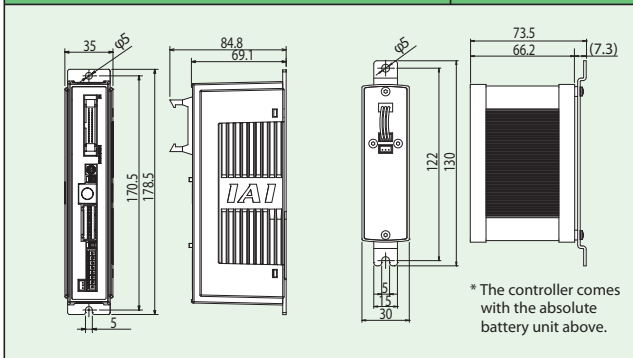

Simple Absolute Specification w/ Absolute Battery Unit DIN Rail Mounting Spec.

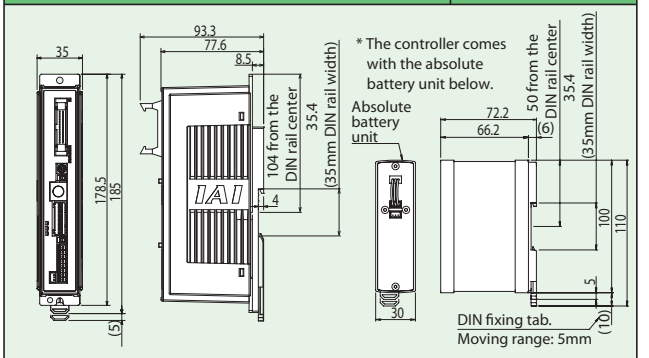

<PCON-CFB/CGFB>

Battery-less Absolute/Incremental Specifications Screw Mounting Spec.

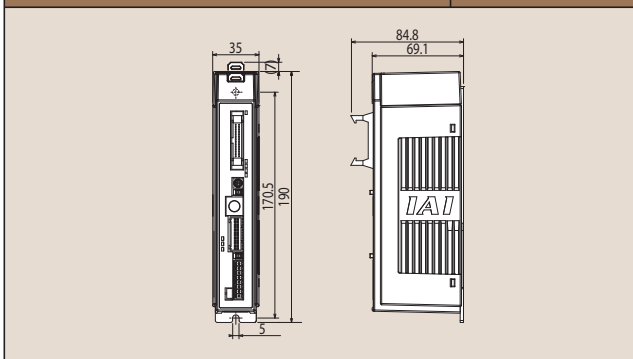

Battery-less Absolute/Incremental Specifications DIN Rail Mounting Spec.

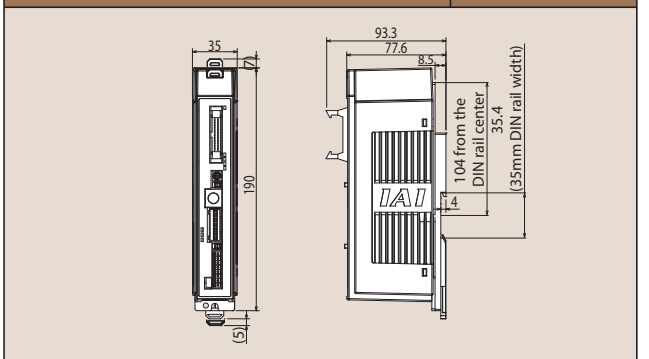

Specification List

Item		Description				
		PCON-CB/CGB	PCON-CFB/CGFB			
Number of controlled axes		1 axis				
Power supply voltage		24VDC±10%				
Load current (including control-side current consumption) (Note 1)	RCP2 RCP3	Motor type	20P, 28P, 28SP	1A max.		
			35P, 42P, 56P	2.2A max.		
			60P, 86P		6A max.	
	RCP4 RCP5	Motor type	28P, 35P, 42P, 42SP, 56P	High-output setting disabled: 2.2A max.		
			56SP, 60P, 86P	High-output setting enabled: 3.5A rated/4.2A max.		6A max.
	RCP6	Motor type	28P, 35P, 42P, 56P	High-output setting disabled: 2.2A max.		
			56SP, 60P	High-output setting enabled: 3.5A rated/4.2A max.		5.7A max.
Electromagnetic brake power (for actuator with brake)		24VDC±10% 0.15A max.		24VDC±10% 0.5A max.		
Inrush current (Note 2)		8.3A		10A		
Momentary power failure resistance		500µs max.				
Compatible encoder		High-resolution battery-less absolute encoder: Resolution 8192 pulses/rev				
		Battery-less absolute encoder: Resolution 800 pulses/rev				
		Incremental encoder: Resolution 800 pulses/rev				
Actuator cable length		20m max.				
External interface	PIO specification		Dedicated 24VDC signal input/output (NPN/PNP selection) ... Input max. of 16 points, output max. of 16 points, cable length max. of 10m			
	Field network specification		DeviceNet, CC-Link, PROFIBUS-DP, CompoNet, EtherCAT, EtherNet/IP, PROFINET IO			
Data setting, input method		PC compatible software, touch panel teaching pendant				
Data retention memory		Position data and parameters are saved in non-volatile memory. (No limit to rewrite)				
Operation mode		Positioner mode / pulse-train control mode (selectable by parameter setting)				
Number of positioner-mode positions		Up to 512 points for positioner type or up to 768 points for network type *The total number of positioning points varies depending on which PIO pattern is selected.				
Pulse-train interface	Input pulse		Differential type (line-driver type): 200kpps max., cable length up to 10m			
			Open-collector method: Not supported * If the host uses open-collector outputs, use AK-04 (optional, sold separately) to change them to differential outputs.			
	Command pulse magnification (Electronic gear: A/B)		1/50 < A/B < 50/1 Setting range of A and B (set by parameters): 1~4,096			
Feedback pulse output		None				
Insulation resistance		Not less than 10MΩ at 500VDC				
Electric shock protection mechanism		Class I, basic insulation				
Mass (Note 3)	Battery-less absolute specification/ Incremental specification		Screw mounting type: Not more than 250g DIN rail mounting type: Not more than 285g	Screw mounting type: Not more than 270g DIN rail mounting type: Not more than 305g		
	Simple absolute specification (including 190g for battery)		Screw mounting type: Not more than 450g DIN rail mounting type: Not more than 485g			
Cooling method		Natural air cooling		Forced air cooling		
Environment	Ambient operating temperature		0~40°C			
	Ambient operating humidity		Not more than 85% RH (non-condensing)			
	Operating ambience		Free from corrosive gases			
	Degree of protection		IP20			

Note 1) 0.3A higher for the field network specification.

Note 2) Inrush current flows for approx. 5msec after the power is input (at 40°C). Please note that the inrush current value varies depending on the impedance of the power line.

Note 3) 30g heavier for the field network specification.

Options

Touch panel teaching pendant

■ **Features** A teaching device equipped with functions such as position teaching, trial operation, and monitoring.

■ **Model** **TB-02-C**

■ **Configuration**

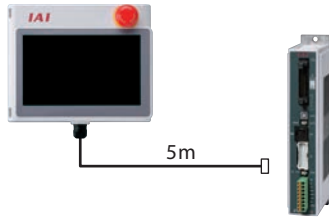

■ **Specifications**

Rated voltage	24VDC
Power consumption	3.6W or less (150mA or less)
Ambient operating temperature	0~40°C
Ambient operating humidity	20~80% RH (Non-condensing)
Environmental resistance	IP20
Weight	470g (TB-02 unit only)

PC compatible software (Windows only)

■ **Features** The start-up support software which comes equipped with functions such as position teaching, trial operation, and monitoring. A complete range of functions needed for making adjustments contributes to a reduced start-up time.

■ **Model** **RCM-101-MW** (with an external device communication cable + RS232 conversion unit)

Please contact IAI for the current supported versions.

■ **Configuration**

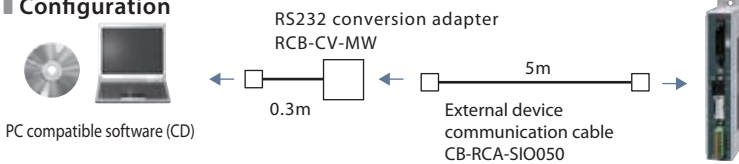

Supported Windows versions:
XP SP2 or later / Vista / 7 / 8



■ **Model** **RCM-101-USB** (with an external device communication cable + USB conversion adapter + USB cable)

Please contact IAI for the current supported versions.

■ **Configuration**

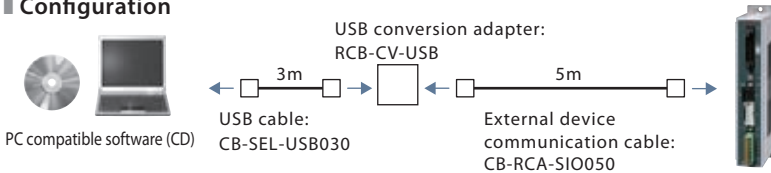

Absolute battery unit

■ **Overview** A battery unit, supplied as an accessory for the simple absolute specification, which serves to back up the current position of the controller.

■ **Model** **SEP-ABU** (DIN rail mounting specification)
SEP-ABUS (Screw mounting specification)

■ **Specification**

Item	Specification
Ambient operating temp. & humidity	0~40°C (around 20°C is desirable), 95% RH or less (non-condensing)
Operating ambience	Free from corrosive gases
Absolute battery	Model: AB-7 (Ni-MH battery/Life: approx. 3 years)
Absolute battery unit connecting cable	Model: CB-APSEP-AB005 (length: 0.5m)
Weight	Standard type: approx.230g/Dust-proof type: approx.260g

Replacement battery

■ **Overview** Replacement battery used with the absolute battery box.

■ **Model** **AB-7**

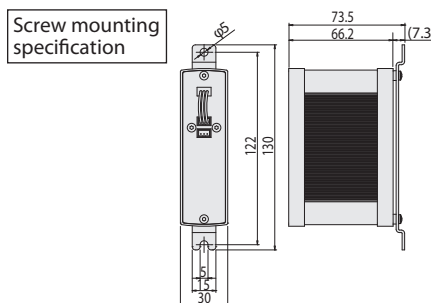
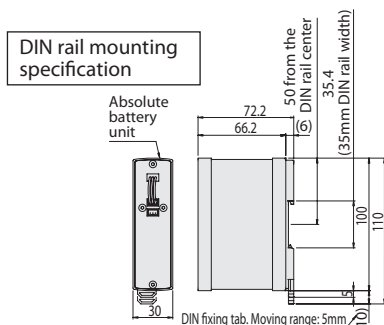

Dummy plug

■ **Overview** This plug is required when the safety category specification (PCON-CGB/CGFB) is used.

■ **Model** **DP-5**



Maintenance Parts

When placing an order for the replacement cable, please use the model number shown below.

Table of Applicable Cables

Model Number		Integrated Motor-encoder Cable	Integrated Motor-encoder Robot Cable
①	RCP6/RCP5/RCP5CR/RCP5W (Models other than ③)	CB-CAN-MPA□□□	CB-CAN-MPA□□□-RB
②	RCP4 SA3/RA3/GR		
③	RCP6 SA8/RRA8 RCP5 RA7 (High-thrust specification)/RA8/RA10 RCP5W WSA16/WRA16	CB-CFA3-MPA□□□	CB-CFA3-MPA□□□-RB
④	RCP4/RCP4CR/RCP4W (Models other than ②, ⑤, ⑥)	CB-CA-MPA□□□	CB-CA-MPA□□□-RB
⑤	RCP4 RA6C (High-thrust specification)	CB-CFA2-MPA□□□	CB-CFA2-MPA□□□-RB
⑥	RCP4W RA7C (High-thrust specification)		
⑦	RCP3	-	CB-APSEP-MPA□□□
⑧	RCP2 GRSS/GRLS/GRST/GRHM/GRHB SRA4R/SRGS4R/SRGD4R	-	CB-RPSEP-MPA□□□
⑨		RTBS/RTBSL RTCS/RTCSL	
⑩	RCP2CR RCP2W GRS/GRM GR3SS/GR3SM	CB-CAN-MPA□□□	CB-CAN-MPA□□□-RB
⑪			
⑫	RCP2 RCP2CR RCP2W RA10/HS8 RA8	CB-CFA-MPA□□□	CB-CFA-MPA□□□-RB
⑬	RCP2W SA16C	-	CB-PSEP-MPA□□□
⑭	RCP2 (Models other than ⑧ ~ ⑬)	-	CB-PSEP-MPA□□□

Model Number	PIO Flat Cable
⑮	PCON-CB/CGB, CFB/CGFB CB-PAC-PIO□□□

Model Number **CB-CAN-MPA□□□/CB-CAN-MPA□□□-RB**

* Please indicate the cable length (L) in □□□, maximum 20m, e.g.) 080 = 8m

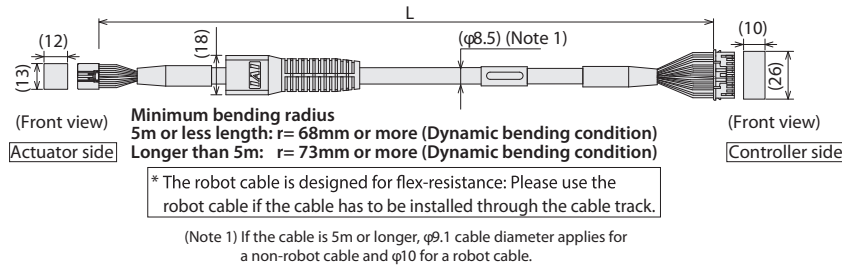

Pin No	Signal name	Pin No	Signal name
3	φA	1	φA
5	VMM	2	VMM
10	φB	3	φB
9	VMM	4	VMM
4	φ A	5	φ A
15	φ B	6	φ B
8	LS+	7	LS+
14	LS-	8	LS-
12	SA(mABS)	11	SA(mABS)
17	SB(mABS)	12	SB(mABS)
1	A+	13	A+
6	A-	14	A-
11	B+	15	B+
16	B-	16	B-
20	BK+	9	BK+
2	BK-	10	BK-
21	VCC	17	VCC
7	GND	19	GND
18	VPS	18	VPS
13	LS_GND	20	LS_GND
19	-	22	-
22	-(CFVcc)	21	-(CFVcc)
23	-	23	-
24	FG	24	FG

Model Number **CB-CFA3-MPA□□□/ CB-CFA3-MPA□□□-RB**

* Please indicate the cable length (L) in □□□, maximum 20m, e.g.) 080 = 8m

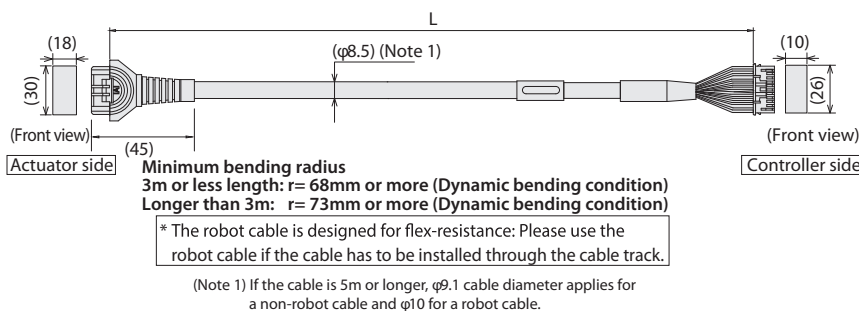

Pin No	Signal name	Pin No	Signal name
A1	φA	1	φA
B1	VMM	2	VMM
A2	φ A	5	φ A
B2	φB	3	φB
A3	VMM	4	VMM
B3	φ B	6	φ B
A4	LS+	7	LS+
B4	LS-	8	LS-
A6	SA(mABS)	11	SA(mABS)
B6	SB(mABS)	12	SB(mABS)
A7	A+	13	A+
B7	A-	14	A-
A8	B+	15	B+
B8	B-	16	B-
A5	BK+	9	BK+
B5	BK-	10	BK-
A9	LS_GND	20	LS_GND
B9	VPS	18	VPS
A10	VCC	21	VCC
B10	GND	19	GND
A11	-	22	-
-	-	23	-
-	-	24	FG

Maintenance Parts

When placing an order for the replacement cable, please use the model number shown below.

Model Number **CB-CA-MPA**□□□/ **CB-CA-MPA**□□□-**RB**

* Please indicate the cable length (L) in □□□, maximum 20m, e.g.) 080 = 8m

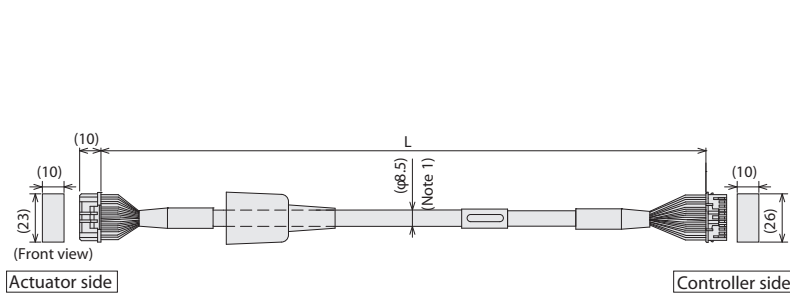

Minimum bending radius $r = 80\text{mm}$ or more (Dynamic bending condition)

* The robot cable is designed for flex-resistance: Please use the robot cable if the cable has to be installed through the cable track.

(Note 1) If the cable is 5m or longer, φ9.1 cable diameter applies for a non-robot cable and φ10 for a robot cable.

Actuator side 1-1827863-1 (AMP)			Controller side PADP-24V-1-S (J.S.T.MFG.CO.,LTD.)		
Pin No	Signal name	Color	Pin No	Signal name	Color
A1	φA/U	Blue (Black)	1	φA/U	Blue (Black)
B1	VMM/V	Orange (White)	2	VMM/V	Orange (White)
A2	φ A/W	Green (Brown)	5	φ A/W	Green (Brown)
B2	φB/-	Brown (Green)	3	φB/-	Brown (Green)
A3	VMM/-	Gray (Yellow)	4	VMM/-	Gray (Yellow)
B3	φ B/+	Red (Red)	6	φ B/+	Red (Red)
A4	LS+/BK+	Black (Orange)	7	LS+/BK+	Black (Orange)
B4	LS-/BK-	Yellow (Gray)	8	LS-/BK-	Yellow (Gray)
A6	-/A+	Blue (White)	11	-/A+	Blue (White)
B6	-/A-	Orange (Yellow)	12	-/A-	Orange (Yellow)
A7	A+/B+	Green (Red)	13	A+/B+	Green (Red)
B7	A-/B-	Brown (Green)	14	A-/B-	Brown (Green)
A8	B+/Z+	Gray (Black)	15	B+/Z+	Gray (Black)
B8	B-/Z-	Red (Brown)	16	B-/Z-	Red (Brown)
A5	BK+/LS+	Blue (Black)	9	BK+/LS+	Blue (Black)
B5	BK-/LS-	Orange (Brown)	10	BK-/LS-	Orange (Brown)
A9	LS_GND	Green (Green)	20	LS_GND	Green (Green)
B9	VPS	Red (Red)	18	VPS	Brown (Red)
A10	VCC	Gray (White)	17	VCC	Gray (White)
B10	GND	Red (Yellow)	19	GND	Red (Yellow)
A11	-	-	21	-	-
B11	FG	Black (-)	22	-	-
			23	-	-
			24	FG	Black (-)

* () indicates the color of the robot cable.

Model Number **CB-CFA-MPA**□□□/ **CB-CFA-MPA**□□□-**RB**

* Please indicate the cable length (L) in □□□, maximum 20m, e.g.) 080 = 8m

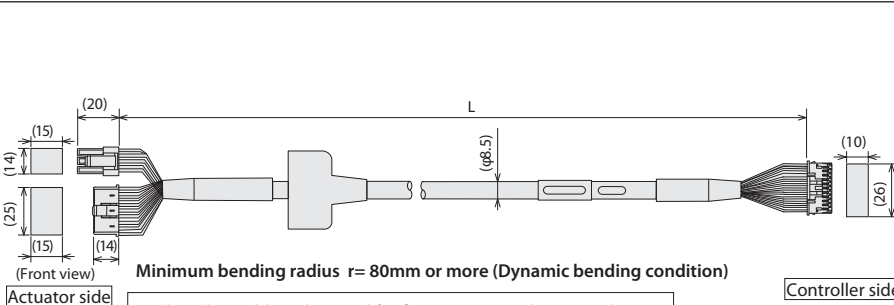

Minimum bending radius $r = 80\text{mm}$ or more (Dynamic bending condition)

* The robot cable is designed for flex-resistance: Please use the robot cable if the cable has to be installed through the cable track.

(Note 1) If the cable is 3m or longer, φ9.1 cable diameter applies for a non-robot cable and φ10 for a robot cable.

Actuator side SLP-06V (NICHATSU)		Controller side PADP-24V-1-S (J.S.T.MFG.CO.,LTD.)	
Pin No	Signal name	Pin No	Signal name
1	φA	1	φA
2	VMM	2	VMM
3	φB	3	φB
4	VMM	4	VMM
5	φA	5	φA
6	φB	6	φB
5	NC	11	NC
6	NC	12	NC
13	LS+	7	LS+
14	LS-	8	LS-
1	A+	13	A+
2	A-	14	A-
3	B+	15	B+
4	B-	16	B-
16	BK+	9	BK+
17	BK-	10	BK-
12	VCC	21	VCC
9	GND	18	GND
10	NC	20	NC
18	FG	24	FG
15	NC	17	NC
8	NC	23	NC

Model Number **CB-CFA2-MPA**□□□/ **CB-CFA2-MPA**□□□-**RB**

* Please indicate the cable length (L) in □□□, maximum 20m, e.g.) 080 = 8m

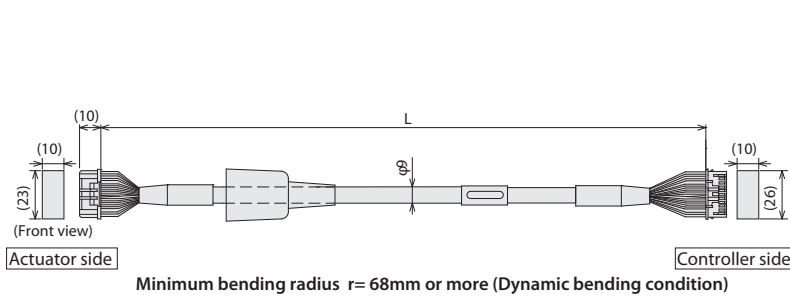

Minimum bending radius $r = 68\text{mm}$ or more (Dynamic bending condition)

* The robot cable is designed for flex-resistance: Please use the robot cable if the cable has to be installed through the cable track.

Actuator side 1-1827863-1 (AMP)		Controller side PADP-24V-1-S (J.S.T.MFG.CO.,LTD.)	
Pin No	Signal name	Pin No	Signal name
A1	φA	1	φA
B1	VMM	2	VMM
A2	φ A	5	φ A
B2	φB	3	φB
A3	VMM	4	VMM
B3	φ B	6	φ B
A4	LS+	7	LS+
B4	LS-	8	LS-
A6	-	11	-
B6	-	12	-
A7	A+	13	A+
B7	A-	14	A-
A8	B+	15	B+
B8	B-	16	B-
A5	BK+	9	BK+
B5	BK-	10	BK-
A9	LS_GND	20	LS_GND
B9	VPS	18	VPS
A10	VCC	17	VCC
B10	GND	19	GND
A11	-	21	-
B11	FG	22	-
		23	-
		24	FG

Model Number **CB-APSEP-MPA**□□□

* Please indicate the cable length (L) in □□□, maximum 20m, e.g.) 080 = 8m

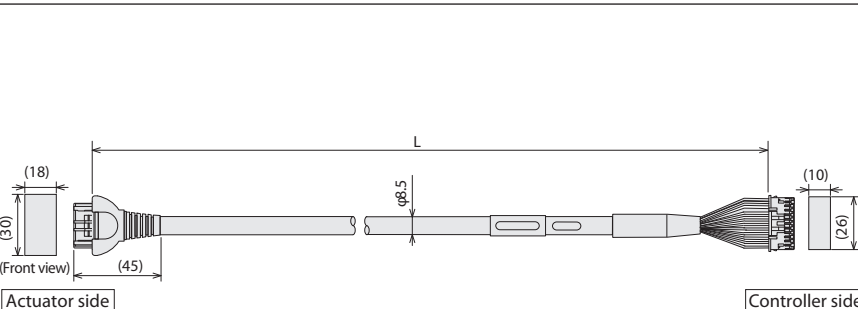

Minimum bending radius $r = 68\text{mm}$ or more (Dynamic bending condition)

* Only robot cable is available for this model.

Actuator side Terminal number	(PCON) (ACON)	Controller side Terminal number
A1	Black (φA) (U)	1
B1	White (VMM) (V)	2
A2	Brown (φA) (W)	5
B2	Green (φB) (-)	3
A3	Yellow (VMM) (-)	4
B3	Red (φB) (+)	6
A4	Orange (LS+) (BK+)	7
B4	Gray (LS-) (BK-)	8
A6	White (A+) (A+)	11
B6	Yellow (A-) (A-)	12
A7	Red (A+) (B+)	13
B7	Green (A-) (B-)	14
A8	Black (B+) (Z+)	15
B8	Brown (B-) (Z-)	16
A5	Black (identification tape) (BK+) (LS+)	9
B5	Brown (identification tape) (BK-) (LS-)	10
A9	Green (identification tape) (GND.S) (GND.S)	20
B9	Red (identification tape) (VPS) (VPS)	18
A10	White (identification tape) (VCC) (VCC)	17
B10	Yellow (identification tape) (GND) (GND)	19
A11	NC	21
B11	Shield (FG) (FG)	22
	NC	23

Maintenance Parts

Model Number **CB-PSEP-MPA**□□□

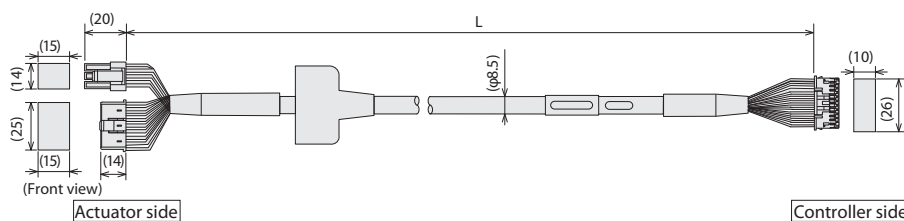

Minimum bending radius $r = 68\text{mm}$ or more (Dynamic bending condition)
 * Only robot cable is available for this model.

* Please indicate the cable length (L) in □□□, maximum 20m, e.g.) 080 = 8m

Actuator side Terminal number		Controller side Terminal number
1	Black (qA)	1
2	White (VMM)	2
4	Red (qB)	3
5	Green (VMM)	4
3	Brown (qA)	5
6	Yellow (qB)	6
16	Orange (BK-)	9
17	Gray (BK-)	10
5	NC	11
6	NC	12
13	Black (LS-)	7
14	Brown (LS-)	8
1	White (A+)	13
2	Yellow (A+)	14
9	Red (identification tape) (GND)	19
4	Green (B-)	15
10	White (identification tape) (VCC)	17
11	Yellow (identification tape) (VPS)	18
12	Red (identification tape) (GND)	20
12	Green (identification tape) (reserve)	20
15	NC	21
8	NC	22
18	Shield (FG)	23
		24

Model Number **CB-RPSEP-MPA**□□□

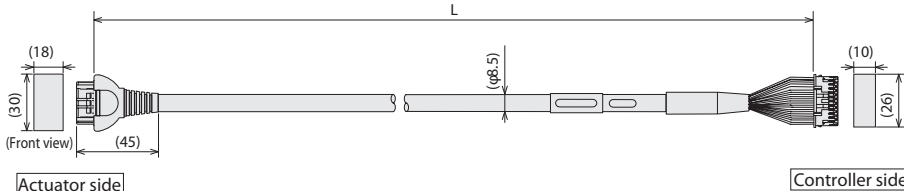

Minimum bending radius $r = 68\text{mm}$ or more (Dynamic bending condition)
 * Only robot cable is available for this model.

* Please indicate the cable length (L) in □□□, maximum 20m, e.g.) 080 = 8m

Actuator side Terminal number		Controller side Terminal number
A1	Black (qA)	1
B1	White (VMM)	2
A2	Brown (qA)	3
B2	Green (qB)	4
A3	Yellow (VMM)	5
B3	Red (qB)	6
A6	Orange (LS-)	7
B6	Gray (LS-)	8
A7	Red (A+)	13
B7	Green (A-)	14
A8	Black (B+)	15
B8	Brown (B-)	16
A4	NC	-
B4	NC	-
A5	Black (identification tape) (BK-)	9
B5	Brown (identification tape) (BK-)	10
A9	Green (identification tape) (GNDLS)	20
B9	Red (identification tape) (VPS)	18
A10	White (identification tape) (VCC)	17
B10	Yellow (identification tape) (GND)	19
A11	NC	21
B11	Shield (FG) (FG)	24
	NC	23
	NC	23

Model Number **CB-PAC-PIO**□□□

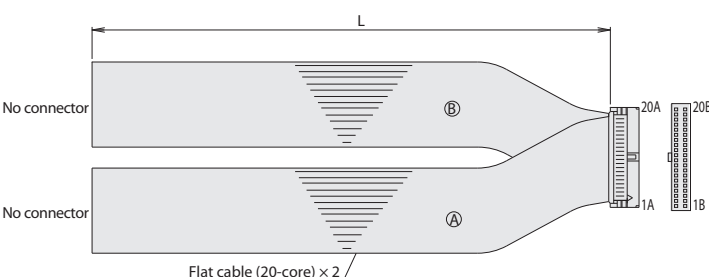

* Please indicate the cable length (L) in □□□, maximum 10m, e.g.) 080 = 8m

No.	Signal name	Cable color	Wiring	No.	Signal name	Cable color	Wiring
1A	24V	Brown-1		1B	OUT0	Brown-3	
2A	24V	Red-1		2B	OUT1	Red-3	
3A	Pulse	Orange-1		3B	OUT2	Orange-3	
4A	Input	Yellow-1		4B	OUT3	Yellow-3	
5A	IN0	Green-1		5B	OUT4	Green-3	
6A	IN1	Blue-1		6B	OUT5	Blue-3	
7A	IN2	Purple-1		7B	OUT6	Purple-3	
8A	IN3	Gray-1		8B	OUT7	Gray-3	
9A	IN4	White-1		9B	OUT8	White-3	
10A	IN5	Black-1		10B	OUT9	Black-3	
11A	IN6	Brown-2		11B	OUT10	Brown-4	
12A	IN7	Red-2		12B	OUT11	Red-4	
13A	IN8	Orange-2		13B	OUT12	Orange-4	
14A	IN9	Yellow-2		14B	OUT13	Yellow-4	
15A	IN10	Green-2		15B	OUT14	Green-4	
16A	IN11	Blue-2		16B	OUT15	Blue-4	
17A	IN12	Purple-2		17B	Pulse	Purple-4	
18A	IN13	Gray-2		18B	input	Gray-4	
19A	IN14	White-2		19B	0V	White-4	
20A	IN15	Black-2		20B	0V	Black-4	

RCP6S with Built-in Controller

Built-in controller for RCP6S

Features

By using the gateway unit, a maximum of 16 axes* of RCP6S (relayed through a hub unit) can be operated via a field network with less wiring.

Hub unit allows us to keep the cable connected to the actuator of each axis short, and motor power supply and control signal lines can be connected as one cable between the hub unit and the RCP6S.

*The number of connectable axes will vary depending on the type of field network and its mode. Please refer to P. 149 for more information.

Control Panel for the RCP6S Built-in Controller Actuator

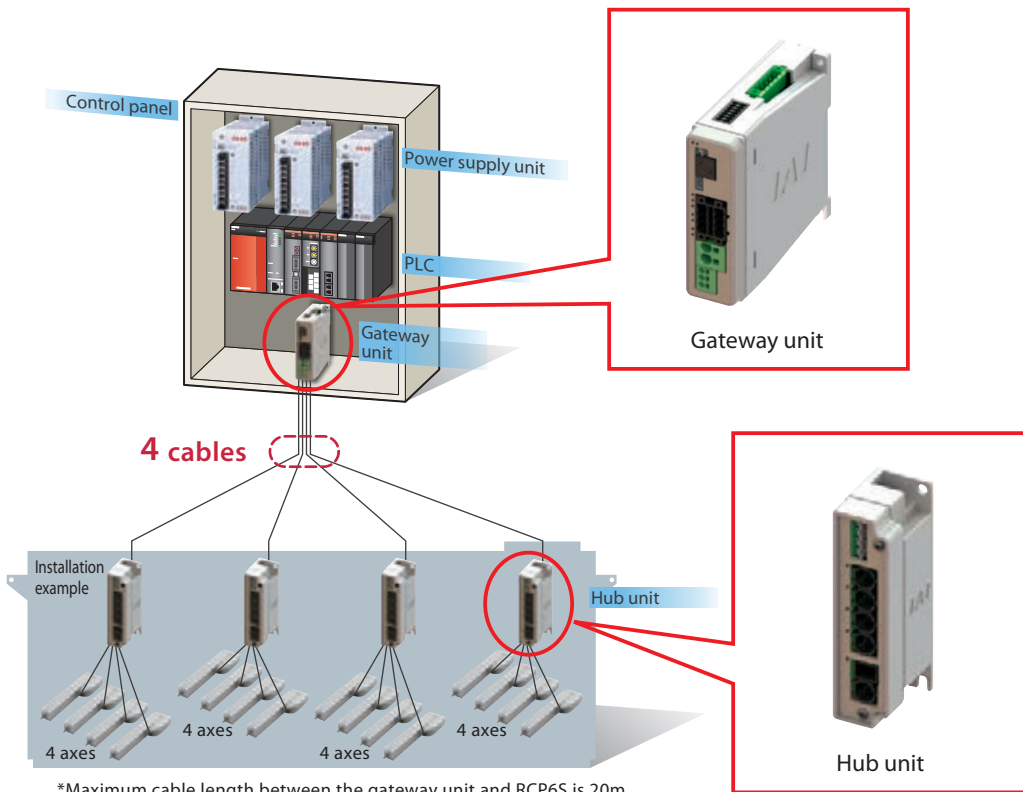

*Maximum cable length between the gateway unit and RCP6S is 20m.
If there is a hub unit in between, the maximum length is still 20m.
The cable length from the gateway unit to the hub unit needs to be 10m or less.

RCP6S Peripheral Equipment

Gateway unit is required in order to operate RCP6S.

- Gateway unit: This unit is used in order to connect RCP6S to the field network. See P. 149
- Hub unit: This unit can expand the number of axes connected to the gateway unit. See P. 152
- PLC connection unit: This unit is used to connect RCP6S directly to the PLC using Modbus serial communication. See P. 153

Basic Controller Specification List

Specification		Specification Description	
Number of controlled axes		1 axis	
Power supply voltage		24VDC±10%	
Control power capacity		0.3A (Built-in controller only)	
Load current (including control-side current consumption)	Motor type	28P, 35P, 42P, 56P	3.2A max. (High-output enabled) 1.7A max. (High-output disabled)
		56SP, 60P	5.7A max.
Electromagnetic brake power (for actuator with brake)		24VDC±10% 0.15A (Note) For releasing brake, 0.7A for 0.2 sec is required.	
Heat output		5W (Motor type 28P, 35P, 42P, 56P) 19.2W (Motor type 56SP, 60P)	
Inrush current (Note 1)	Motor type	28P, 35P, 42P, 56P	8.3A (With inrush current protection circuitry)
		56SP, 60P	10A (With inrush current protection circuitry)
Motor control method		Weak field vector control	
Compatible encoder		Resolution of battery-less absolute encoder: 8192 pulses/rev	
Actuator cable length		20m max.	
Serial communication interface (SIO port)		RS485: 1CH (Modbus protocol RTU/ASCII compliant) Speed: 9.6~230.4Kbps 1CH (Modbus protocol RTU)	
External interface		Field bus connection: DeviceNet, CC-Link, PROFIBUS-DP, EtherCAT, EtherNet/IP, PROFINET-IO. (Note) Additional gateway unit connection is required.	
Data setting, input method		PC compatible software, touch panel teaching pendant	
Data retention memory		Position data and parameters are saved in non-volatile memory. (No limit to rewrite)	
LED display		SV (green) / ALM (red): Servo ON / Alarm triggered and emergency stop	
Insulation resistance		Not less than 10MΩ at 500VDC	
Electric shock protection mechanism		Class I basic insulation	
Cooling method		Natural air cooling	

Note1: Inrush current will flow for approximately 5msec after the power is turned on (at 40°C).

Inrush current value differs depending on the impedance on the power supply line.

<The Calculation of Number of Connectable Axes and Power Capacity>

To calculate the number of axes connectable to one gateway unit and the current amperage of 24VDC, figure out (1) to (5) below and follow (6).

(1) The Calculation of Number of Connectable Axes, and Motor Current Consumption

Condition 1: Sum of motor current consumption connectable to one hub unit: 12.8A or less

Condition 2: Number of controlled axes connectable to corresponding 1 unit: 4 axes or less

* By adjusting the number of connected axes or motor type, select the connected axes so each hub unit satisfies the formulas below.

● Sum of motor current consumption for hub unit = Motor current consumption of 1st axis + Motor current consumption of 2nd axis (if connected)
+ Motor current consumption of 3rd axis (if connected)
+ Motor current consumption of 4th axis (if connected) ≤ 12.8A.....①

● Sum of motor current consumption = Motor current consumption of hub unit 1st unit
+ Motor current consumption of 2nd hub unit (if connected)
+ Motor current consumption of 3rd hub unit (if connected)
+ Motor current consumption of 4th hub unit (if connected)②

(2) Control Power Current Consumption: 0.3A × Number of actuator + 0.6A (gateway unit) + 0.3A × Number of hub unit③

(3) Consumption current when excited phase detected: The maximum current value of the total motor consumption current when servos are turned on at the same time ④

(4) Inrush Current: 8.3A (Motor type 28P, 35P, 42P, 56P) 10A (Motor type 56SP, 60P)⑤

(5) Current Consumption of Brake Release: Number of actuators with brake × 0.7A⑥

* When servo is on, it should be 0.5sec or less, after that retaining of released status should be 0.1A / axis.

(6) Selection of Power Supply:

Usually, the rated current is to be approximately 1.2 times higher than the total of Control Power ② + ③ + ⑥ above considering approximately 20% of margin to the load current.

However, although it is for a short time, current of ④ and ⑤ will flow, so please take this into account and select a "peak load support" specification or select a power supply that has sufficient headroom. Avoid having all of the current from ④ and ⑤ from flowing at the same time by turning the servos on at different times from each other (Note 1).

If a power supply with insufficient headroom is selected, voltage may drop instantaneously. Be careful especially when selecting a power source equipped with remote sensing.

Note 1: The timing to turn the servo on can be tuned in Parameter No. 165 [Latency after Shutdown Release].

(Note) Ensure motor and control power supplies reference the same potential when using multiple power supplies.

Gateway Unit (RCM-P6GW)

Features:

This unit is used in order to connect RCP6S to the field network.

Details:

- Compatible with many field networks.
(Applicable networks: CC-Link, DeviceNet, PROFIBUS-DP, EtherCAT, EtherNet/IP, PROFINET-IO)
- Motor power and control power for all of the connected axes can be supplied through the gateway unit.
- Monitoring during AUTO is possible.
- A mini-USB connection comes standard.
- Each channel has MPO/MPI for drive source cutoff.
- Brake can be forcibly released by supplying power to the brake release input terminal for each channel. (In the case that the actuator is directly connected)
- When RCP6S is directly connected to the gateway unit, the communication time is 10msec. When RCP6S is connected to the gateway unit through the hub unit, the communication time is 40msec. The communication time does not become longer even if the connected axes increase.



Model Configuration

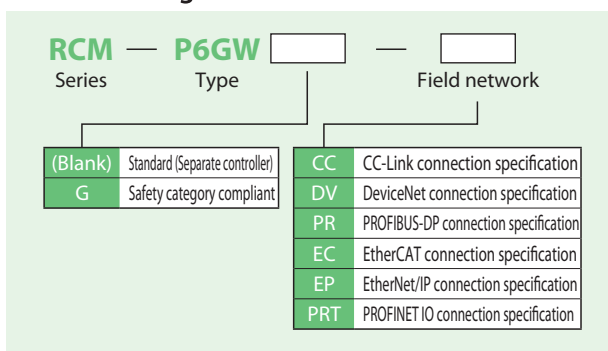

Available Models

Models
CC-Link specification
DeviceNet specification
PROFIBUS specification
EtherCAT specification
EtherNet/IP specification
PROFINET IO specification
Safety category CC-Link specification
Safety category DeviceNet specification
Safety category PROFIBUS-DP specification
Safety category EtherCAT specification
Safety category EtherNet/IP specification
Safety category PROFINET IO specification

*For safety category compliant specification, DP-5 will be included.

Connection Image

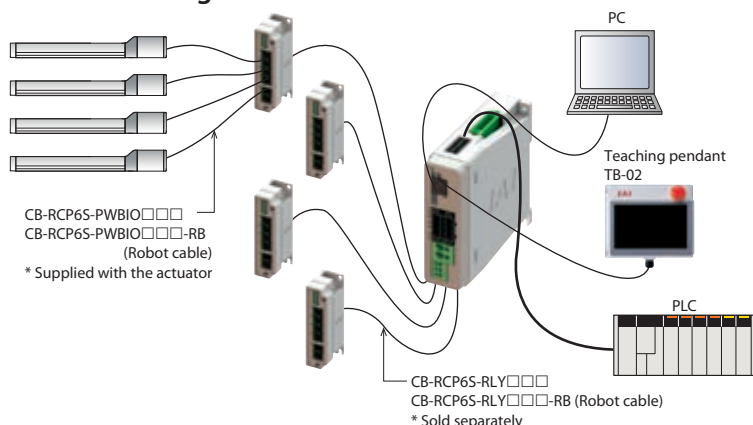

Up to 16 axes^(*) of RCP6S can be connected per gateway unit with hub units.^(**)
 Because both the motor power and control power for all the axes connected to the gateway unit can be supplied together, the required wiring for RCP6S can be connected as one cable between the hub and RCP6S.

Also RCP6S can be directly connected to the gateway unit.

(*1) Number of connectable axes varies depending on the type of the field network. Please see "Number of connectable axes" table for details.
 (*2) Hub unit: Refer to P. 152 for the details.

The Number of Connectable Axes:

Maximum connectable axes for RCM-P6GW are as shown below.

	Direct value mode	Simple direct value mode	Positioner 1	Positioner 2	Positioner 3	Positioner 5
CC-Link	16	16	16	16	16	16
DeviceNet	8	16	16	16	16	16
PROFIBUS	8	16	16	16	16	16
EtherCAT	8	16	16	16	16	16
EtherNet/IP	8	16	16	16	16	16
PROFINET IO	8	16	16	16	16	16

Field Network Control Operation Mode

These control modes are available to choose from when using the RCP6S via field network. Data required for operation (target position, speed, acceleration, push current value, etc.) are written by a PLC or other host controller into the specified addresses.

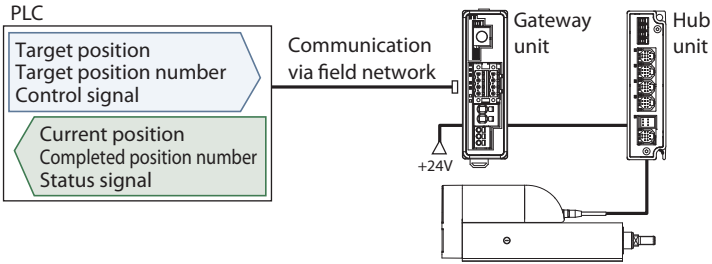
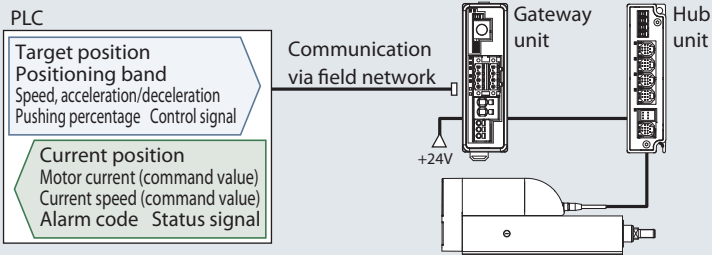
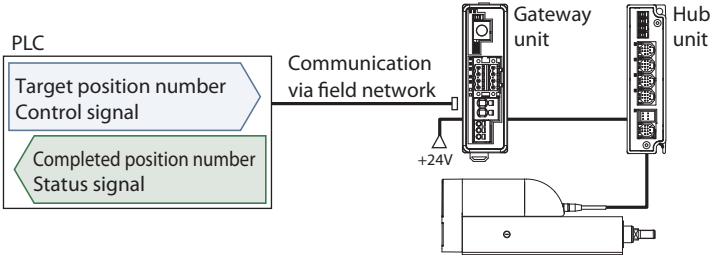
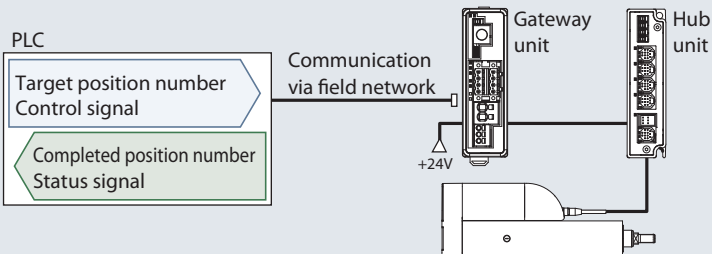
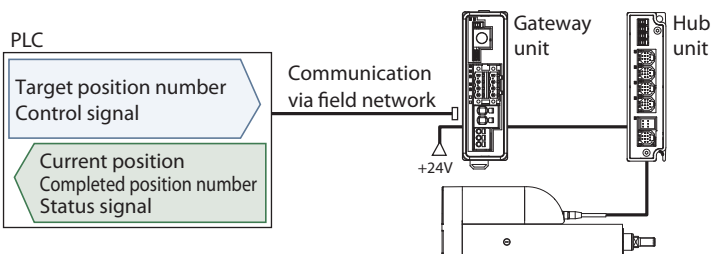
Operation mode	Description	Overview
<p>Positioner 1/ Simple direct numerical value mode (Simple direct mode)</p>	<p>Positioner 1 mode can store up to 256 points of position data, and can move to the stored position. Both modes allow monitoring the current position numerically with 0.01mm increments. The simple direct numerical value mode can modify any of the stored target positions by numerical value. Both modes allow monitoring the current position numerically with 0.01mm increments.</p>	
<p>Direct numerical control mode (Direct indication/ Full mode)</p>	<p>This mode allows designating the target position, speed, acceleration/deceleration, and motor current percentage for pushing numerically. Also, it is capable of monitoring the current position, current speed, and the motor current command value with 0.01mm increments.</p>	
<p>Positioner 2 mode</p>	<p>Positioner 2 mode can store up to 256 points of position data, and can move to the stored position. This mode does not allow monitoring of the current position. This is a mode that has less in/out data transfer volume than the Positioner 1 mode.</p>	
<p>Positioner 3 mode</p>	<p>Positioner 3 mode can store up to 256 points of position data, and can move to the stored position. This mode does not allow monitoring of the current position. This is a mode that has less in/out data transfer volume than the Positioner 2 mode, and operates with a minimum number of signals.</p>	
<p>Positioner 5 mode</p>	<p>Positioner 5 mode can store up to 16 points of position data, and can move to the stored position. This is a mode that has less in/out data transfer volume than the Positioner 2 mode, and allows monitoring the current position numerically with 0.01mm increments.</p>	

List of Functions by Operation Mode

	Simple direct value mode	Positioner 1 mode	Direct numerical control mode (Direct indication/Full mode)	Positioner 2 mode	Positioner 3 mode	Positioner 5 mode
Number of positioning points	256 points	256 points	Unlimited	256 points	256 points	16 points
Home return operation	○	○	○	○	○	○
Positioning operation	○	△	○	△	△	△
Speed, acceleration/deceleration settings	△	△	○	△	△	△
Different acceleration and deceleration settings	△	△	—	△	△	△
Pitch Feed (Incremental)	△	△	○	△	—	△
Push-motion operation	△	△	○	△	△	△
Speed changes while moving	△	△	○	△	△	△
Pausing	○	○	○	○	○	○
Zone signal output	△	△	△	△	△	△
Position zone signal output	△	△	—	△	—	—
Current position reading (Resolution)	○ (0.01mm)	○ (0.01mm)	○ (0.01mm)	—	—	○ (0.1mm)

* ○ indicates that direct setting is possible, △ indicates position data or parameter input is required, — indicates the operation is not supported.

Names and Functions of Each Part

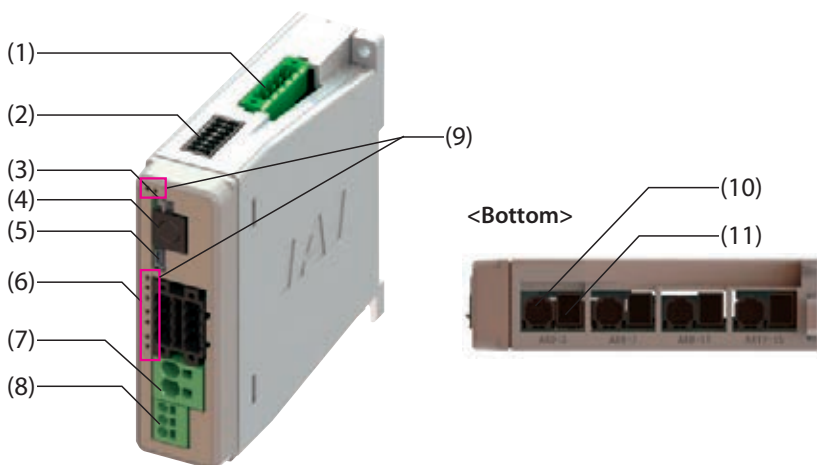

- (1) Field network connector
The connector used to connect to the field network.
- (2) System I/O connector
The connector for emergency stop input, external AUTO/MANU switchover input, and brake release input in case of directly connecting RCP6S to a gateway unit.
- (3) Operation mode setting switch
For switching the operation mode between automatic (AUTO) and manual (MANU).
- (4) SIO connector
The connector used to connect a teaching pendant or PC software.
- (5) USB connector
The connector used to connect the PC software.
- (6) Drive power cut-off connector
The connector used to connect an external drive power cut-off relay to the 24VDC power supply from the motor power connector.
- (7) Motor power supply connector
For 24VDC motor power supply for a gateway unit.
- (8) Control power supply connector
The connector for the gateway unit 24VDC control power supply and the frame ground (FG).
- (9) Status display LED
Displays the status of the gateway unit.

Code	LED	Display color and operating status.
LED1	SYS	System status Ready (Green) Alarm (Red)
LED2	AUTO	Operation mode (AUTO/MANU) status Automatic operation mode (Green)
LED3	EMG	Emergency stop (EMG) status Emergency stop (EMG)(Red)
LED4	T. ERR	Bus communication error in the controller T.ERR (Orange)
LED5	C. ERR	Field bus network communication error C.ERR (Orange)

- (10) Axis control connector
The connector used to supply power and control signals (24VDC control power, 24VDC motor power, communication line, brake release signal, emergency stop status, etc.) from the gateway unit to the hub unit or RCP6S.
- (11) Axis power supply connector
The connector used to supply 24VDC motor power via gateway unit to either a RCP6S or a hub unit.

External Dimensions

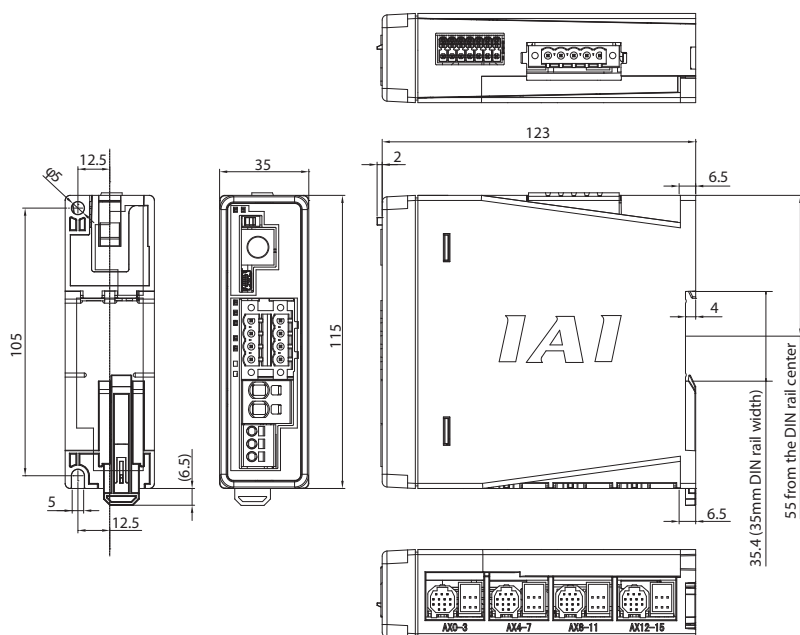

Gateway Unit Basic Specifications

Specification	Description
Number of controlled axes	16 axes max. (4 axes with a single gateway unit)
Power supply voltage	24VDC±10%
Control power capacity	0.6A (0.3A with a single gateway unit + field bus module 0.3A)
Motor power capacity	External 24V power supply Consumption current 56.6A (40A effective)*
Cooling method	Natural air cooling
Emergency stop input	B contact input
Enable input	None
T.P. enable input	Yes
Enable operation	Servo OFF
Backup memory	FRAM (256kbit), No. of overwrites: Unlimited
Calendar function	Yes (retains data for 10 days after power off)
Gateway board LED display	SYS LED × 1 (RUN/ALM), EMG LED × 1, MODE LED × 1 (AUTO/MANU), T.ERR LED × 1, C.ERR LED × 1 Field bus module status LED × 2
Tool connection	T/P connector: RS485 1ch (Modbus protocol compliant) USB connector: USB 1ch
Electromagnetic braking forced release mechanism	System I/O connector: External brake release signal input (24VDC) *Only used when an RCP6S unit is directly connected to the gateway unit. Disabled when a hub is connected.
Electric shock protection mechanism	Class 1, basic insulation
Insulation withstanding voltage	500VDC 10MΩ
Weight	250g
External dimensions	35W × 115H × 123D

*The amount limited by the connectors rated current and PCB trace widths through to the actual 40A value. $40 \times \sqrt{2} = 56.6A$

Options

Hub Unit (RCM-P6HUB)

The hub unit cannot be used alone.
It must be used with a gateway unit.

Features:

The connection between gateway unit - hub unit and hub unit - RCP6S can be established using serial communication. By using a gateway unit with hub units, up to 16 axes can be controlled.

* The number of connectable axes will vary depending on the type of field networks and its mode. Please see P. 149 for the details.

Model Configuration

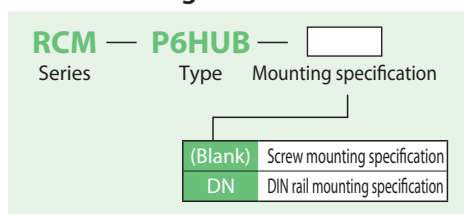

External Dimensions

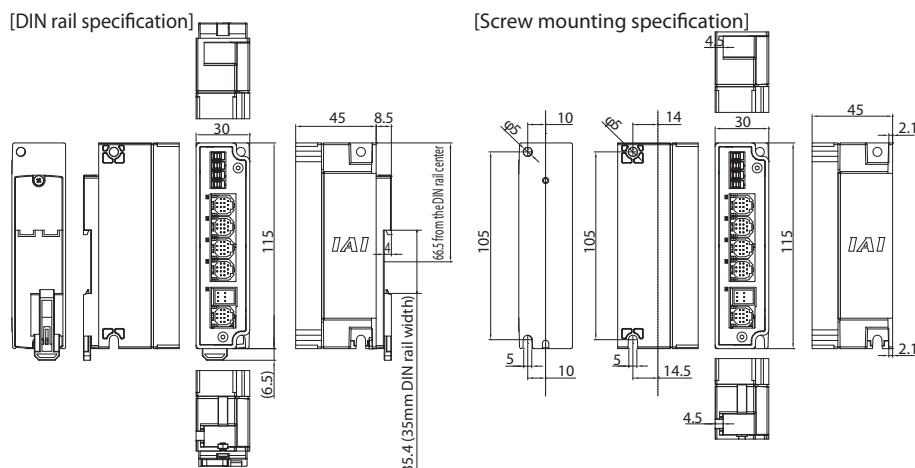

Specification

Specification	Description
Number of controlled axes	4 axes max.
Power supply voltage	24VDC±10%
Control power capacity	0.3A (single hub unit)
Motor power capacity	12.8A max. from connected axes
Emergency stop input	None
Enable input	None
LED display	SYS LED × 1 (RUN/ALM) AXIS LED × 4 (RUN/ALM)
Electromagnetic braking forced release mechanism	External brake release switch × 4
Electric shock protection mechanism	Class 1, basic insulation
Insulation withstanding voltage	500VDC 10MΩ
Contamination	Contamination 2
Weight	80g
External dimensions	35W × 115H × 45D

PLC Connection Unit (RCB-P6PLC)

Features:

This is a terminal block used to connect the RCP6S and the PLC using serial communication. The RCP6S and the PLC connection unit can be easily connected with a cable.

* The gateway unit and the hub unit cannot be connected to this PLC connection unit.

Model Configuration

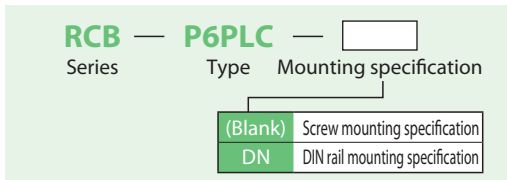

Connection Image

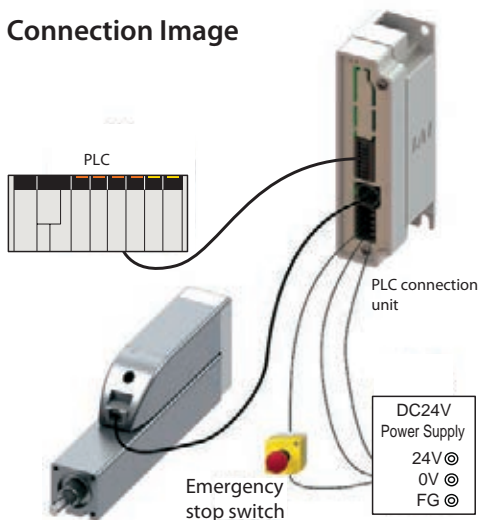

Specification

Specification	Description
Number of controlled axes	1 axis
Power supply voltage	24VDC±10%
Control power capacity	0A for single PLC connection unit 0.3A for connected PLC units + RCP6S built-in driver • For brake type, 0.7A for 0.2 sec is required for releasing brake
Motor power capacity	Depending on RCP6S built-in driver
Emergency stop input	B contact input
Enable input	None
LED display	None
Electromagnetic braking forced release mechanism	External brake release signal input (24VDC)
Electric shock protection mechanism	Class 1, basic insulation
Insulation withstanding voltage	500VDC 10MΩ
Contamination	Contamination 2
Weight	65g
External Dimensions	35W × 115H × 45D

External Dimensions

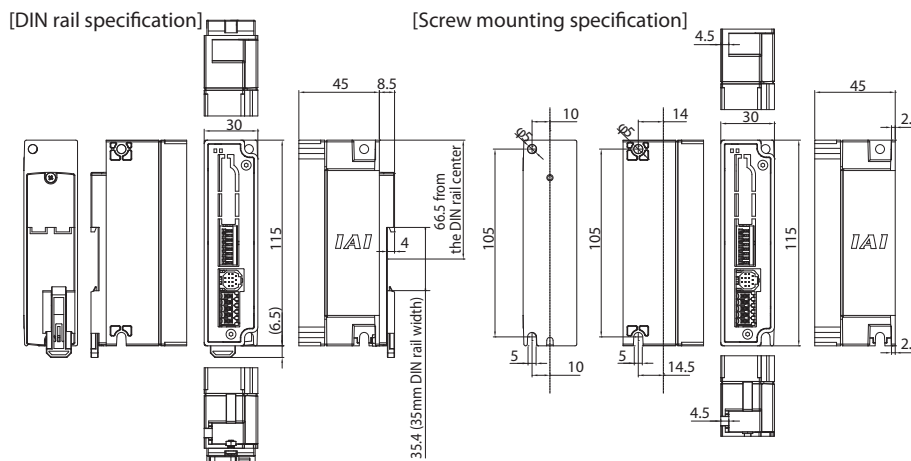

Touch Panel Teaching Pendant

Features

A teaching device equipped with functions such as position teaching, trial operation, and monitoring.

Model **TB-02-C** (See P.143)

PC Compatible Software (for Windows)

Features

This is start-up support software which comes equipped with functions such as position input, trial operation, monitoring, etc. A complete range of functions needed for making adjustments contributes to a reduced start-up time.

Model **RCM-101-MW** (See P.143)
(with an external device communication cable + RS232 conversion unit)

Model **RCM-101-USB** (See P.143)
(with an external device communication cable + USB conversion adapter + USB cable)

Maintenance Parts

When placing an order for the replacement cable, please use the model number shown below. *There are restrictions on the total cable length. Please check with the [Notes] on P. 2.

For connecting RCP6S to gateway unit, hub unit, or PLC connection unit.

Model number **CB-RCP6S-PWBIO** / **CB-RCP6S-PWBIO** -**RB**
 Standard cable Robot cable

* Please indicate the cable length (L) in , maximum 20m, e.g.) 080 = 8m

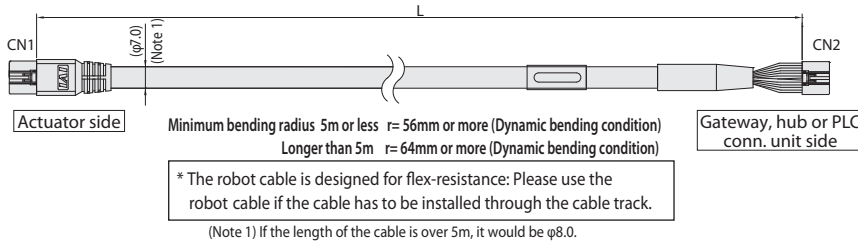

CN1			CN2		
Color	Signal name	Pin No.	Pin No.	Signal name	Color
Gray (AWG22/19)	CP	1	1	CP	Gray (AWG22/19)
Blue (AWG22/19)	MP	8	8	MP	Blue (AWG22/19)
Orange (AWG22/19)	MP	9	9	MP	Orange (AWG22/19)
Green (AWG22/19)	GND	10	10	GND	Green (AWG22/19)
Brown (AWG22/19)	GND	11	11	GND	Brown (AWG22/19)
Orange (AWG26)	AM_SDI+	6	6	AM_SDI+	Orange (AWG26)
Light blue (AWG26)	AM_SDI-	2	2	AM_SDI-	Light blue (AWG26)
Red (AWG26)	CT_SDI+	7	7	CT_SDI+	Red (AWG26)
Gray (AWG26)	CT_SDI-	3	3	CT_SDI-	Gray (AWG26)
Green (AWG26)	BK	4	4	BK	Green (AWG26)
Brown (AWG26)	EMGS	5	5	EMGS	Brown (AWG26)
Black (AWG26)	NC	13	13	NC	Black (AWG26)
Black (AWG26)	FG	12	12	FG	Black (AWG26)

For connecting a gateway unit and a hub unit

Model number **CB-RCP6S-RLY** / **CB-RCP6S-RLY** -**RB**
 Standard cable Robot cable

* Please indicate the cable length (L) in , maximum 10m, e.g.) 030 = 3m
 Available standard lengths: 1m/3m/5m/10m

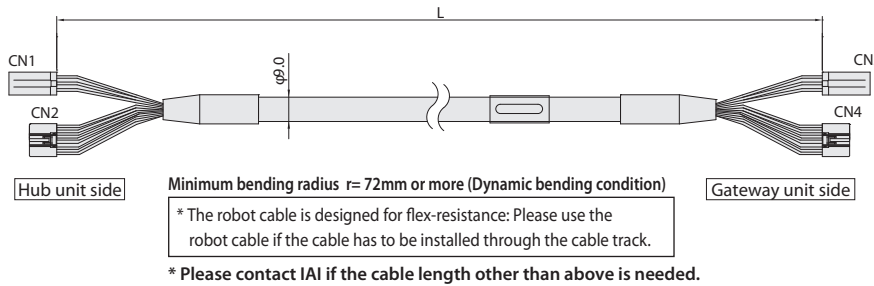

CN1			CN3		
Color	Signal name	Pin No.	Pin No.	Signal name	Color
Brown (AWG18)	MP	B1	B1	MP	Brown (AWG18)
Gray (AWG18)	MP	B2	B2	MP	Gray (AWG18)
Red (AWG18)	MP	B3	B3	MP	Red (AWG18)
Blue (AWG18)	GND	A1	A1	GND	Blue (AWG18)
Orange (AWG18)	GND	A2	A2	GND	Orange (AWG18)
Green (AWG18)	GND	A3	A3	GND	Green (AWG18)

CN2			CN4		
Color	Signal name	Pin No.	Pin No.	Signal name	Color
Blue (AWG22)	CP	1	1	CP	Blue (AWG22)
-	NC	8	8	NC	-
-	NC	9	9	NC	-
Orange (AWG22)	GND	10	10	GND	Orange (AWG22)
Green (AWG22)	GND	11	11	GND	Green (AWG22)
Brown (AWG26)	AM_SDI+	6	6	AM_SDI+	Brown (AWG26)
Green (AWG26)	AM_SDI-	2	2	AM_SDI-	Green (AWG26)
Red (AWG26)	CT_SDI+	7	7	CT_SDI+	Red (AWG26)
Gray (AWG26)	CT_SDI-	3	3	CT_SDI-	Gray (AWG26)
Light blue (AWG26)	NC	4	4	NC	Light blue (AWG26)
Orange (AWG26)	EMGS	5	5	EMGS	Orange (AWG26)
-	NC	13	13	NC	-
Black (AWG26)	FG	12	12	FG	Black (AWG26)

Extension cable for connecting RCP6S to gateway unit, hub unit, or PLC connection unit.

Model number **CB-RCP6S-PWBIO** -**JY1** / **CB-RCP6S-PWBIO** -**JY1-RB**
 Standard cable Robot cable

* Please indicate the cable length (L) in , maximum 20m minus basic cable length, e.g.) 030 = 3m
 Available standard lengths: 1m/3m/5m

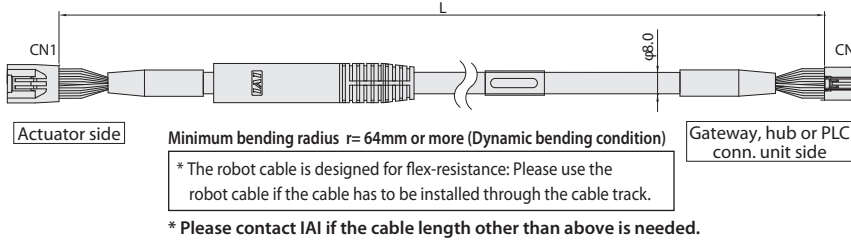

CN1			CN2		
Color	Signal name	Pin No.	Pin No.	Signal name	Color
Gray (AWG18)	CP	1	1	CP	Gray (AWG18)
Blue (AWG18)	MP	8	8	MP	Blue (AWG18)
Orange (AWG18)	MP	9	9	MP	Orange (AWG18)
Green (AWG18)	GND	10	10	GND	Green (AWG18)
Brown (AWG18)	GND	11	11	GND	Brown (AWG18)
Orange (AWG26)	AM_SDI+	6	6	AM_SDI+	Orange (AWG26)
Light blue (AWG26)	AM_SDI-	2	2	AM_SDI-	Light blue (AWG26)
Red (AWG26)	CT_SDI+	7	7	CT_SDI+	Red (AWG26)
Gray (AWG26)	CT_SDI-	3	3	CT_SDI-	Gray (AWG26)
Green (AWG26)	BK	4	4	BK	Green (AWG26)
Brown (AWG26)	EMGS	5	5	EMGS	Brown (AWG26)
Black (AWG26)	NC	13	13	NC	Black (AWG26)
Black (AWG26)	FG	12	12	FG	Black (AWG26)

Extension cable for connecting a gateway unit and a hub unit.

Model number **CB-RCP6S-RLY** -**JY1** / **CB-RCP6S-RLY** -**JY1-RB**
 Standard cable Robot cable

* Please indicate the cable length (L) in , maximum 10m minus basic cable length, e.g.) 030 = 3m
 Available standard lengths: 1m/3m/5m

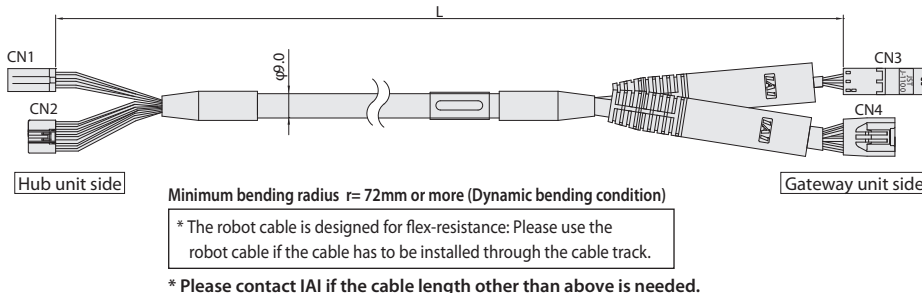

CN1			CN3		
Color	Signal name	Pin No.	Pin No.	Signal name	Color
Brown (AWG18)	MP	B1	B1	MP	Brown (AWG18)
Gray (AWG18)	MP	B2	B2	MP	Gray (AWG18)
Red (AWG18)	MP	B3	B3	MP	Red (AWG18)
Blue (AWG18)	GND	A1	A1	GND	Blue (AWG18)
Orange (AWG18)	GND	A2	A2	GND	Orange (AWG18)
Green (AWG18)	GND	A3	A3	GND	Green (AWG18)

CN2			CN4		
Color	Signal name	Pin No.	Pin No.	Signal name	Color
Blue (AWG22)	CP	1	1	CP	Blue (AWG22)
-	NC	8	8	NC	-
-	NC	9	9	NC	-
Orange (AWG22)	GND	10	10	GND	Orange (AWG22)
Green (AWG22)	GND	11	11	GND	Green (AWG22)
Brown (AWG26)	AM_SDI+	6	6	AM_SDI+	Brown (AWG26)
Green (AWG26)	AM_SDI-	2	2	AM_SDI-	Green (AWG26)
Red (AWG26)	CT_SDI+	7	7	CT_SDI+	Red (AWG26)
Gray (AWG26)	CT_SDI-	3	3	CT_SDI-	Gray (AWG26)
Light blue (AWG26)	NC	4	4	NC	Light blue (AWG26)
Orange (AWG26)	EMGS	5	5	EMGS	Orange (AWG26)
-	NC	13	13	NC	-
Black (AWG26)	FG	12	12	FG	Black (AWG26)

**RCP6/RCP6S Series V1b
Slider / Rod / Table Type
Catalogue No. 0816-E**



The information contained in this catalog is subject to change without notice for the purpose of product improvement



IAI Industrieroboter GmbH

Ober der Röth 4

D-65824 Schwalbach / Frankfurt

Germany

Tel.: +49-6196-8895-0

Fax: +49-6196-8895-24

E-Mail: info@IAI-GmbH.de

Internet: <http://www.eu.IAI-GmbH.de>

IAI America, Inc.

2690 W. 237th Street, Torrance, CA 90505, U.S.A

Phone: +1-310-891-6015, Fax: +1-310-891-0815

IAI (Shanghai) Co., Ltd

Shanghai Jiahua Business Center A8-303, 808,

Hongqiao Rd., Shanghai 200030, China

Phone: +86-21-6448-4753, Fax: +86-21-6448-3992

IAI CORPORATION

577-1 Obane, Shimizu-Ku, Shizuoka, 424-0103 Japan

Phone: +81-543-64-5105, Fax: +81-543-64-5192

IAI Robot (Thailand) Co., Ltd

825 PhairojKijja Tower 12th Floor, Bangna-Trad RD.,

Bangna, Bangna, Bangkok 10260, Thailand

Phone: +66-2-361-4457, Fax: +66-2-361-4456