

**RoboCylinder Standard & Cleanroom Slider  
Types with Battery-less Absolute Encoder**

**PowerCon Controller for RoboCylinder  
High-function Standard & Global Type**

# RCS4/RCS4CR Series SCON-CB/CGB

 **Battery-less Absolute Encoder**  
No Battery,  
No Maintenance, No Homing,  
No Going Back to Incremental.



 **ROBO  
CYLINDER**

# RCS4 BENEFITS

## The advantages of using an absolute encoder

[For incremental encoder]

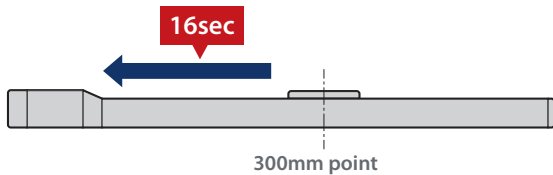

It takes 16 seconds from the 300mm point until home return is completed.

## Home return not required

[For absolute encoder]

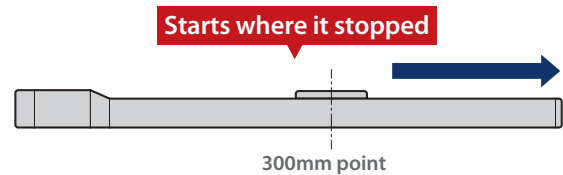

Since the position information is held by the battery, it is unnecessary to perform home return each time.

Normally, in emergency stops...

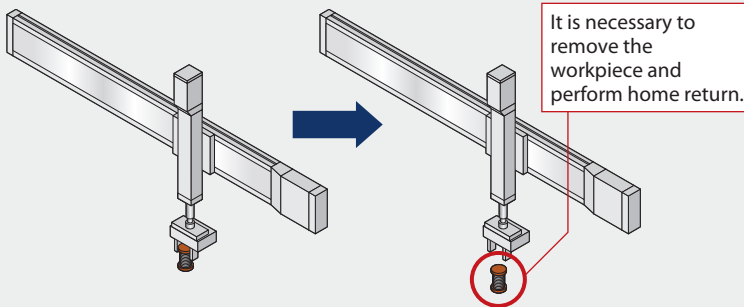

### With absolute encoder

Since home return is unnecessary, there is no need to remove the workpiece and perform home return.

- MERIT 1** The recovery time after device shutdown can be shortened.
- MERIT 2** This reduces the production costs.



## The advantages of battery-less

## Battery replacement not required

- MERIT 1** The battery replacement processes and purchase costs can be reduced.



Replacement guidelines:  
Every 3 years

- MERIT 2** Battery-related trouble such as "voltage drop" will not occur.



The advantages of using an absolute encoder.



The advantages of battery-less



**Battery-less Absolute Encoder**

## An abundant lineup of 54 models



### Slider Type **SA**

The slider on the top of the body actuates. Since it uses a base integrated ball circulating type with a built-in linear guide, it will be able to deal with moments in the pitching, yawing, and rolling directions.



### Wide Slider Type **WSA**

The slider on the top of the body actuates. The ball circulating linear guide is built into the wide body. External guides are not required, even for applications with large overhangs.



### Rod Type **RA**

The rod actuates in the same manner as the rod type air cylinder. This actuator type has no built-in linear guide and costs the least among the RCS4 rod types.



### Radial Cylinder **RRA**

The rod actuates in the same manner as the rod type air cylinder. Since ball circulating type linear guides are built in, it can take moment loads. External guides are not required.



### Wide Radial Cylinder **WRA**

The rod actuates in the same manner as the rod type air cylinder. Due to a wide body and high rigidity rod, it can deal with up to four times the allowable torque on rod tip compared to a radial cylinder.



### Table Type **TA**

The table actuates on top of the main body. A ball circulating type linear guide is built into the table. Double block can be selected as an option, so that the two guide blocks increase the allowable dynamic moment.

### Radial Cylinder **RRA**

You may not believe it, but...

## A guide is not required!

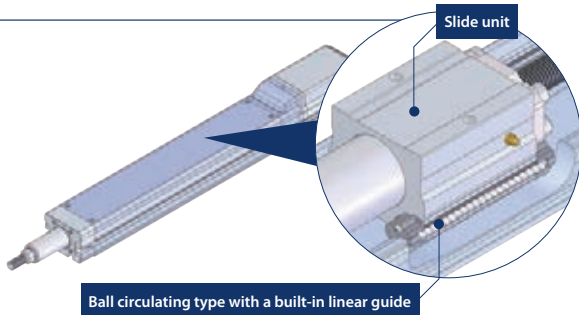

Since ball circulating type linear guides are built into the rod type body, it can take radial loads and moment loads. The equipment will be compact since an external guide is unnecessary.

### Wide Slider Type **WSA**

Since it uses a built-in ball circulating type with a built-in linear guide inside its wide body, it will be able to deal with high load moments in the pitching, yawing, and rolling directions. Since it is flat, it is ideal when the space in the height direction is limited.

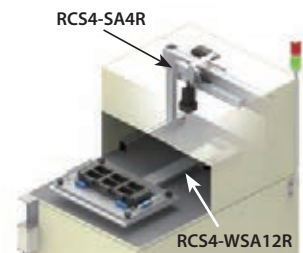

Device using an air cylinder

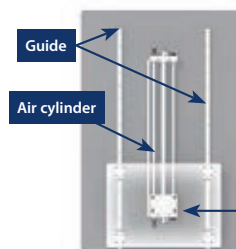

Device using RoboCylinder

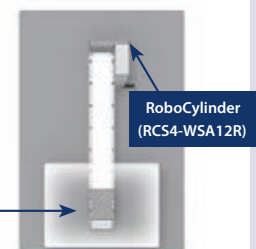

# Product Lineup

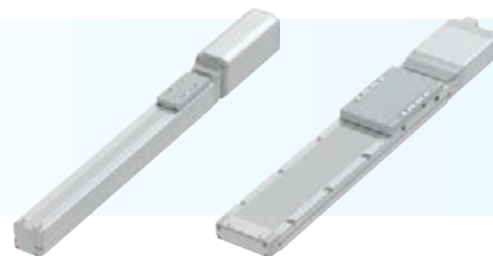

## Slider Type: SA

Motor	Type	External view	Body width (mm)	Motor wattage (W)	Lead (mm)	Positioning repeatability (mm)	Stroke (mm)	Max speed (mm/s)	Rated thrust (N)	Max. payload (kg)		Reference page
										Horizontal	Vertical	
Coupled Motor	SA4C		40mm	60	16	±0.01 [±0.005]	50~500 (50mm increments)	960	53	10	3	p11
					10			600	85	14	5	
					5			300	170	17	8	
					2.5			150	340	20	12	
	SA6C		60mm	100	30	±0.01	50~800 (50mm increments)	1600	57	11	3.5	p13
					20			1200	85	18	6	
					12			720	142	30	11	
					6			360	283	45	15	
	SA7C		70mm	200	36	±0.01	50~800 (50mm increments)	1800	95	7	4	p15
					24			1500	142	30	7	
					16			1000	214	40	12	
					8			500	427	45	20	
	SA8C		90mm	400	48	±0.01	50~1100 (50mm increments)	2200	141	8	-	p17
					30			1800	226	30	12	
					20			1200	339	60	20	
					10			600	678	80	35	
Side-mounted Motor	SA4R		40mm	60	16	±0.01	50~500 (50mm increments)	960	53	10	2.5	p19
					10			600	85	14	4.5	
					5			300	170	17	8	
					2.5			150	340	20	12	
	SA6R		60mm	100	30	±0.01	50~800 (50mm increments)	1600	57	11	3	p21
					20			1200	85	18	5	
					12			720	142	30	9	
					6			360	283	45	15	
	SA7R		70mm	200	36	±0.01	50~800 (50mm increments)	1800	95	7	4	p23
					24			1500	142	30	6	
					16			1000	214	38	12	
					8			500	427	45	18	
	SA8R		90mm	400	48	±0.01	50~1100 (50mm increments)	2100	141	8	-	p25
					30			1800	226	30	12	
					20			1200	339	60	20	
					10			600	678	80	35	
					5		300	1357	90	45		

Values in [ ] are for high-precision specification.

## Wide Slider Type: WSA

Motor	Type	External view	Body width (mm)	Motor wattage (W)	Lead (mm)	Positioning repeatability (mm)	Stroke (mm)	Max speed (mm/s)	Rated thrust (N)	Max. payload (kg)		Reference page
										Horizontal	Vertical	
Coupled Motor	WSA10C		100mm	60	16	±0.01 [±0.005]	50~500 (50mm increments)	960	53	7	-	p27
					10			600	85	16	3	
					5			300	170	27	5	
					2.5			150	340	40	10	
	WSA12C		120mm	100	30	±0.01	50~800 (50mm increments)	1600	57	5	-	p29
					20			1200	85	15	3	
					12			720	142	25	8	
					6			360	283	45	15	
	WSA14C		140mm	200	36	±0.01	50~800 (50mm increments)	1800	95	7	-	p31
					24			1440	142	20	2.5	
					16			960	214	45	8	
					8			480	427	65	10	
	WSA16C		160mm	400	48	±0.01	50~1100 (50mm increments)	2400	141	8	-	p33
					30			1800	226	30	12	
					20			1200	339	60	20	
					10			600	678	80	35	
Side-mounted Motor	WSA10R		100mm	60	16	±0.01	50~500 (50mm increments)	960	53	7	-	p35
					10			600	85	16	3	
					5			300	170	27	5	
					2.5			150	340	40	10	
	WSA12R		120mm	100	30	±0.01	50~800 (50mm increments)	1600	57	5	-	p37
					20			1200	85	13	3	
					12			720	142	23	8	
					6			360	283	43	15	
	WSA14R		140mm	200	36	±0.01	50~800 (50mm increments)	1800	95	7	-	p39
					24			1440	142	20	2.5	
					16			960	214	45	8	
					8			480	427	65	10	
	WSA16R		160mm	400	48	±0.01	50~1100 (50mm increments)	2400	141	8	-	p41
					30			1800	226	30	12	
					20			1200	339	60	18	
					10			600	678	80	35	
					5		300	1357	100	50		

Values in [ ] are for high-precision specification.

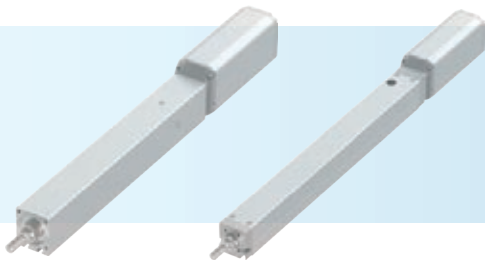

## Rod Type: RA

Motor	Type	External view	Body width (mm)	Motor wattage (W)	Lead (mm)	Positioning repeatability (mm)	Stroke (mm)	Max speed (mm/s)	Rated thrust (N)	Max. payload (kg)		Reference page
										Horizontal	Vertical	
Coupled Motor	RA4C		40mm	60	16	±0.01	50~200 (50mm increments)	800	53	8	2	p43
					10			500	85	18	4	
					5			250	170	30	6	
					2.5			125	340	40	10	
	RA6C		60mm	100	20	±0.01	50~300 (50mm increments)	1000	85	15	4	p45
					12			600	142	25	10	
					6			300	283	50	20	
					3			150	566	60	20	
	RA7C		70mm	200	24	±0.01	50~300 (50mm increments)	1200	142	20	6	p47
					16			800	214	45	12	
					8			400	427	60	25	
					4			200	855	80	35	
RA8C		90mm	400	20	±0.01	50~300 (50mm increments)	1000	399	60	20	p49	
				10			500	678	80	40		
				5			250	1357	100	72		
Side-mounted Motor	RA4R		40mm	60	16	±0.01	50~200 (50mm increments)	800	53	8	2	p51
					10			500	85	18	4	
					5			250	170	30	6	
					2.5			125	340	40	10	
	RA6R		60mm	100	20	±0.01	50~300 (50mm increments)	1000	85	15	4	p53
					12			600	142	25	9	
					6			300	283	50	19	
					3			150	566	60	20	
	RA7R		70mm	200	24	±0.01	50~300 (50mm increments)	1200	142	20	6	p55
					16			800	214	45	12	
					8			400	427	60	25	
					4			200	855	80	35	
RA8R		90mm	400	20	±0.01	50~300 (50mm increments)	1000	339	60	20	p57	
				10			500	678	80	40		
				5			250	1357	100	72		

## Radial Cylinder: RRA

Motor	Type	External view	Body width (mm)	Motor wattage (W)	Lead (mm)	Positioning repeatability (mm)	Stroke (mm)	Max speed (mm/s)	Rated thrust (N)	Max. payload (kg)		Reference page
										Horizontal	Vertical	
Coupled Motor	RRA4C		40mm	60	16	±0.01	60~410 (50mm increments)	960	53	8	2	p59
					10			600	85	18	4	
					5			300	170	30	6	
					2.5			150	340	40	10	
	RRA6C		60mm	100	20	±0.01	65~415 (50mm increments)	1200	85	15	4	p61
					12			720	142	25	10	
					6			360	283	50	20	
					3			180	566	60	20	
	RRA7C		70mm	200	24	±0.01	70~520 (50mm increments)	1440	142	20	6	p63
					16			960	214	45	12	
					8			480	427	60	25	
					4			240	855	80	35	
RRA8C		90mm	400	30	±0.01	50~700 (50mm increments)	1500	226	30	8	p65	
				20			1100	339	60	20		
				10			550	678	80	40		
				5			275	1357	100	72		
Side-mounted Motor	RRA4R		40mm	60	16	±0.01	60~410 (50mm increments)	960	53	8	2	p67
					10			600	85	18	4	
					5			300	170	30	6	
					2.5			150	340	40	10	
	RRA6R		60mm	100	20	±0.01	65~415 (50mm increments)	1200	85	15	4	p69
					12			720	142	25	9	
					6			360	283	50	19	
					3			180	566	60	20	
	RRA7R		70mm	200	24	±0.01	70~520 (50mm increments)	1440	142	20	6	p71
					16			960	214	45	12	
					8			480	427	60	25	
					4			240	855	80	35	
RRA8R		90mm	400	30	±0.01	50~700 (50mm increments)	1300	226	30	8	p73	
				20			1000	339	60	17		
				10			550	678	80	34		
				5			275	1357	100	72		

Foreword  
Slider Type  
Wide Slider Type  
Rod Type  
Radial Cylinder  
Wide Radial Cylinder  
Table Type  
Cleanroom Slider  
Cleanroom Wide Slider  
Options  
Reference Data  
Controller

# Product Lineup



## Wide Radial Cylinder: WRA

Motor	Type	External view	Body width (mm)	Motor wattage (W)	Lead (mm)	Positioning repeatability (mm)	Stroke (mm)	Max speed (mm/s)	Rated thrust (N)	Max. payload (kg)		Reference page
										Horizontal	Vertical	
Coupled Motor	WRA10C		100mm	60	16	±0.01	50~500 (50mm increments)	800	53	5	-	p75
					10			600	85	16	3	
					5			300	170	25	5	
					2.5			150	340	40	10	
	WRA12C		120mm	100	20	±0.01	50~500 (50mm increments)	1000	85	12	2	p77
					12			720	142	25	6	
					6			360	283	40	15	
					3			180	566	60	20	
	WRA14C		140mm	200	24	±0.01	50~600 (50mm increments)	1200	142	25	3	p79
					16			800	214	50	8	
					8			480	427	65	20	
					4			240	855	85	30	
WRA16C		160mm	400	30	±0.01	50~800 (50mm increments)	1300	226	30	6	p81	
				20			1000	339	60	12		
				10			500	678	80	35		
				5			250	1357	100	50		
Side-mounted Motor	WRA10R		100mm	60	16	±0.01	50~500 (50mm increments)	800	53	5	-	p83
					10			600	85	13	2.5	
					5			300	170	25	5	
					2.5			150	340	40	10	
	WRA12R		120mm	100	20	±0.01	50~500 (50mm increments)	1000	85	12	2	p85
					12			720	142	25	6	
					6			360	283	40	15	
					3			180	566	60	20	
	WRA14R		140mm	200	24	±0.01	50~600 (50mm increments)	1200	142	25	3	p87
					16			800	214	50	8	
					8			480	427	65	20	
					4			240	855	85	30	
WRA16R		160mm	400	30	±0.01	50~800 (50mm increments)	1300	226	30	6	p89	
				20			1000	339	60	12		
				10			500	678	80	35		
				5			250	1357	100	50		

## Table Type: TA

Motor	Type	External view	Body width (mm)	Motor wattage (W)	Lead (mm)	Positioning repeatability (mm)	Stroke (mm)	Max speed (mm/s)	Rated thrust (N)	Max. payload (kg)		Reference page
										4[-]	1.5[-]	
Coupled Motor	TA4C		40mm	60	16(*)	±0.01	Single-block 25~150 (25mm increments) Double-block 40~90 (25mm increments) 140, 190, 240	900[-]	53[-]	4[-]	1.5[-]	p91 p93
					10			600	85	5[8]	3	
					5			300	170	5[10]	6	
					2.5			150	340	5[10]	9	
	TA6C		60mm	100	20(*)	±0.01	Single-block 25~200 (25mm increments) Double-block 45~120 (25mm increments) 170~320 (50mm increments)	1100[-]	85[-]	8[-]	4[-]	p95 p97
					12			720	142	8[14]	6	
					6			360	283	8[20]	10	
					3			180	566	10[20]	12	
	TA7C		70mm	200	24(*)	±0.01	Single-block 25~200 (25mm increments) 250, 300 Double-block 40~90 (25mm increments) 140~390 (50mm increments)	1300[-]	142[-]	12[-]	5[-]	p99 p101
					16			960	214	15[25]	10[8]	
					8			480	427	15[30]	18	
					4			240	855	15[30]	20[24]	
Side-mounted Motor	TA4R		40mm	60	16(*)	±0.01	Single-block 25~150 (25mm increments) Double-block 40~90 (25mm increments) 140, 190, 240	800[-]	53[-]	4[-]	1.5[-]	p103 p105
					10			600	85	5[8]	3	
					5			300	170	5[10]	6	
					2.5			150	340	5[10]	9	
	TA6R		60mm	100	20(*)	±0.01	Single-block 25~200 (25mm increments) Double-block 45~120 (25mm increments) 170~320 (50mm increments)	1000[-]	85[-]	8[-]	4[-]	p107 p109
					12			720	142	8[14]	6	
					6			360	283	8[20]	10	
					3			180	566	10[20]	10[12]	
	TA7R		70mm	200	24(*)	±0.01	Single-block 25~200 (25mm increments) 250, 300 Double-block 40~90 (25mm increments) 140~390 (50mm increments)	1200[-]	142[-]	12[-]	5[-]	p111 p113
					16			960	214	15[25]	10[8]	
					8			480	427	15[30]	18	
					4			240	855	15[30]	20[24]	

(\*) Single-block (SB) specification only. Values in brackets [ ] are for the double-block (DB) specification.

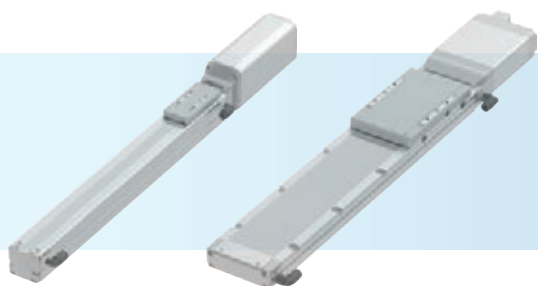

## Slider Type SA <Cleanroom Specification>

Motor	Type	External view	Body width (mm)	Motor wattage (W)	Lead (mm)	Positioning repeatability (mm)	Stroke (mm)	Max Speed (mm/s)	Rated thrust (N)	Max. payload (kg)		Cleanliness	Reference page	
										Horizontal	Vertical			
Coupled Motor	SA4C		40mm	60	16	±0.01 [±0.005]	50~500 (50mm increments)	960	53	10	3	ISO Class 2.5 Equivalent (ISO Std. 14644-1:2015)	p115	
					10			600	85	14	5			
					5			300	170	17	8			
					2.5			150	340	20	12			
	SA6C		60mm	100	20	±0.01 [±0.005]	50~800 (50mm increments)	1200	85	18	6		p117	
					12			720	142	30	11			
					6			360	283	45	15			
					3			180	566	45	15			
	SA7C		70mm	200	24	±0.01 [±0.005]	50~800 (50mm increments)	1500	142	30	7		US FED Class 10 (Fed. Std. 209D)	p119
					16			1000	214	40	12			
					8			500	427	45	20			
					4			240	855	50	25			
	SA8C		90mm	400	20	±0.01 [±0.005]	50~1100 (50mm increments)	1200	339	60	20		p121	
					10			600	678	80	35			
					5			300	1357	90	45			

Values in [ ] are for high-precision specification.

## Wide Slider Type WSA <Cleanroom Specification>

Motor	Type	External view	Body width (mm)	Motor wattage (W)	Lead (mm)	Positioning repeatability (mm)	Stroke (mm)	Max Speed (mm/s)	Rated thrust (N)	Max. payload (kg)		Cleanliness	Reference page	
										Horizontal	Vertical			
Coupled Motor	WSA10C		100mm	60	16	±0.01 [±0.005]	50~500 (50mm increments)	960	53	7	-	ISO Class 2.5 Equivalent (ISO Std. 14644-1:2015)	p123	
					10			600	85	16	3			
					5			300	170	27	5			
					2.5			150	340	40	10			
	WSA12C		120mm	100	20	±0.01 [±0.005]	50~800 (50mm increments)	1200	85	15	3		p125	
					12			720	142	25	8			
					6			360	283	45	15			
					3			180	566	55	15			
	WSA14C		140mm	200	24	±0.01 [±0.005]	50~800 (50mm increments)	1440	142	20	2.5		US FED Class 10 (Fed. Std. 209D)	p127
					16			960	214	45	8			
					8			480	427	65	10			
					4			240	855	80	25			
	WSA16C		160mm	400	20	±0.01 [±0.005]	50~1100 (50mm increments)	1200	339	60	20		p129	
					10			600	678	80	35			
					5			300	1357	100	50			

Values in [ ] are for high-precision specification.

Foreword

Slider Type

Wide Slider Type

Rod Type

Radial Cylinder

Wide Radial Cylinder

Table Type

Cleanroom Slider

Cleanroom Wide Slider

Options

Reference Data

Controller

# Model Specification Items

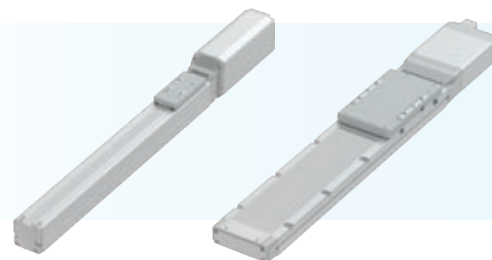

## Slider Type: SA

**RCS4** — [ ] — **WA** — [ ] — [ ] — [ ] — [ ] — [ ] — [ ] — [ ]

Series      Type      Encoder Type      Motor Type      Ball Screw Lead      Stroke      Applicable Controllers      Cable Length      Options

Encoder Type	Motor Type
<b>WA</b> Battery-less Absolute	
<b>60</b> 60W	
<b>100</b> 100W	
<b>200</b> 200W	
<b>400</b> 400W	

Ball Screw Lead	Stroke
<b>2.5</b> 2.5mm	<b>50</b> 50mm
<b>3</b> 3mm	?
<b>4</b> 4mm	?
<b>5</b> 5mm	<b>1100</b> 1100mm
<b>6</b> 6mm	(50mm increments)
<b>8</b> 8mm	
<b>10</b> 10mm	
<b>12</b> 12mm	
<b>16</b> 16mm	
<b>20</b> 20mm	
<b>24</b> 24mm	
<b>30</b> 30mm	
<b>36</b> 36mm	
<b>48</b> 48mm	

Applicable Controllers
<b>T2</b> SCON, MSCON, SSEL, XSEL-P/Q, XSEL-RA/SA

Options
<b>N</b> None
<b>P</b> 1m
<b>S</b> 3m
<b>M</b> 5m
<b>X</b> <input type="checkbox"/> Specified length (Standard cable)
<b>R</b> <input type="checkbox"/> Robot cable
<b>B</b> Brake
<b>CJT</b> Cable exit direction (Top)
<b>CJR</b> Cable exit direction (Right)
<b>CJL</b> Cable exit direction (Left)
<b>CJO</b> Cable exit direction (Outside)
<b>CJB</b> Cable exit direction (Bottom)
<b>HPR</b> High-precision Specification
<b>ML</b> Motor side-mounted to left (standard)
<b>MR</b> Motor side-mounted to right
<b>NM</b> Non-motor End Specification
<b>RP</b> Back mounting plate
<b>SS</b> Slider spacer
<b>SR</b> Slider Roller Specification
<b>W</b> Double Slider Specification
<b>EU</b> Round cable joint connector

Series	Type
<b>SA4C</b>	Body width 40mm Coupled motor type
<b>SA6C</b>	Body width 60mm Coupled motor type
<b>SA7C</b>	Body width 70mm Coupled motor type
<b>SA8C</b>	Body width 90mm Coupled motor type
<b>SA4R</b>	Body width 40mm Side-mounted motor type
<b>SA6R</b>	Body width 60mm Side-mounted motor type
<b>SA7R</b>	Body width 70mm Side-mounted motor type
<b>SA8R</b>	Body width 90mm Side-mounted motor type

\*The type of motor, ball screw lead, stroke, and selection options vary depending on the actuator type. Please refer to the pages of each type for details.

## Wide Slider Type: WSA

**RCS4** — [ ] — **WA** — [ ] — [ ] — [ ] — [ ] — [ ] — [ ] — [ ]

Series      Type      Encoder Type      Motor Type      Ball Screw Lead      Stroke      Applicable Controllers      Cable Length      Options

Encoder Type	Motor Type
<b>WA</b> Battery-less Absolute	
<b>60</b> 60W	
<b>100</b> 100W	
<b>200</b> 200W	
<b>400</b> 400W	

Ball Screw Lead	Stroke
<b>2.5</b> 2.5mm	<b>50</b> 50mm
<b>3</b> 3mm	?
<b>4</b> 4mm	?
<b>5</b> 5mm	<b>1100</b> 1100mm
<b>6</b> 6mm	(50mm increments)
<b>8</b> 8mm	
<b>10</b> 10mm	
<b>12</b> 12mm	
<b>16</b> 16mm	
<b>20</b> 20mm	
<b>24</b> 24mm	
<b>30</b> 30mm	
<b>36</b> 36mm	

Applicable Controllers
<b>T2</b> SCON, MSCON, SSEL, XSEL-P/Q, XSEL-RA/SA

Options
<b>N</b> None
<b>P</b> 1m
<b>S</b> 3m
<b>M</b> 5m
<b>X</b> <input type="checkbox"/> Specified length (Standard cable)
<b>R</b> <input type="checkbox"/> Robot cable
<b>B</b> Brake
<b>CJT</b> Cable exit direction (Top)
<b>CJR</b> Cable exit direction (Right)
<b>CJL</b> Cable exit direction (Left)
<b>CJO</b> Cable exit direction (Outside)
<b>CJB</b> Cable exit direction (Bottom)
<b>HPR</b> High-precision Specification
<b>ML</b> Motor side-mounted to left (standard)
<b>MR</b> Motor side-mounted to right
<b>NM</b> Non-motor End Specification
<b>SS</b> Slider spacer
<b>SR</b> Slider Roller Specification
<b>EU</b> Round cable joint connector

Series	Type
<b>WSA10C</b>	Body width 100mm Coupled motor type
<b>WSA12C</b>	Body width 120mm Coupled motor type
<b>WSA14C</b>	Body width 140mm Coupled motor type
<b>WSA16C</b>	Body width 160mm Coupled motor type
<b>WSA10R</b>	Body width 100mm Side-mounted motor type
<b>WSA12R</b>	Body width 120mm Side-mounted motor type
<b>WSA14R</b>	Body width 140mm Side-mounted motor type
<b>WSA16R</b>	Body width 160mm Side-mounted motor type

\*The type of motor, ball screw lead, stroke, and selection options vary depending on the actuator type. Please refer to the pages of each type for details.



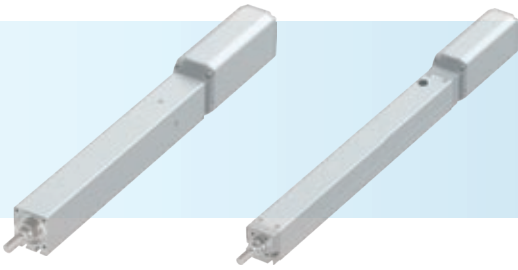

## Rod Type: RA

**RCS4** — [ ] — **WA** — [ ] — [ ] — [ ] — [ ] — [ ] — [ ] — [ ]

Series      Type      Encoder Type      Motor Type      Ball Screw Lead      Stroke      Applicable Controllers      Cable Length      Options

Series	Type	Encoder Type	Motor Type	Ball Screw Lead	Stroke	Applicable Controllers	Cable Length	Options
<b>RA4C</b>	Body width 40mm Coupled motor type	<b>WA</b> Battery-less Absolute	<b>60</b> 60W <b>100</b> 100W <b>200</b> 200W <b>400</b> 400W	<b>2.5</b> 2.5mm <b>3</b> 3mm <b>4</b> 4mm <b>5</b> 5mm <b>6</b> 6mm <b>8</b> 8mm <b>10</b> 10mm <b>12</b> 12mm <b>16</b> 16mm <b>20</b> 20mm <b>24</b> 24mm	<b>50</b> 50mm ? ? <b>300</b> 300mm (50mm increments)	<b>T2</b> SCON MSCON SSEL XSEL-P/Q XSEL-RA/SA	<b>N</b> None <b>P</b> 1m <b>S</b> 3m <b>M</b> 5m <b>X</b> <input type="checkbox"/> Specified length (Standard cable) <b>R</b> <input type="checkbox"/> Robot cable	<b>B</b> Brake <b>CJT</b> Cable exit direction (Top) <b>CJR</b> Cable exit direction (Right) <b>CJL</b> Cable exit direction (Left) <b>CJO</b> Cable exit direction (Outside) <b>CJB</b> Cable exit direction (Bottom) <b>FL</b> Flange <b>FT</b> Foot bracket <b>ML</b> Motor side-mounted to left (standard) <b>MR</b> Motor side-mounted to right <b>NFA</b> Tip adapter (Internal thread) <b>NM</b> Non-motor End Specification <b>NTB</b> T-slot nut bar <b>RP</b> Back mounting plate <b>EU</b> Round cable joint connector
<b>RA6C</b>	Body width 60mm Coupled motor type							
<b>RA7C</b>	Body width 70mm Coupled motor type							
<b>RA8C</b>	Body width 90mm Coupled motor type							
<b>RA4R</b>	Body width 40mm Side-mounted motor type							
<b>RA6R</b>	Body width 60mm Side-mounted motor type							
<b>RA7R</b>	Body width 70mm Side-mounted motor type							
<b>RA8R</b>	Body width 90mm Side-mounted motor type							

\*The type of motor, ball screw lead, stroke, and selection options vary depending on the actuator type. Please refer to the pages of each type for details.

## Radial Cylinder: RRA

**RCS4** — [ ] — **WA** — [ ] — [ ] — [ ] — [ ] — [ ] — [ ] — [ ]

Series      Type      Encoder Type      Motor Type      Ball Screw Lead      Stroke      Applicable Controllers      Cable Length      Options

Series	Type	Encoder Type	Motor Type	Ball Screw Lead	Stroke	Applicable Controllers	Cable Length	Options
<b>RRA4C</b>	Body width 40mm Coupled motor type	<b>WA</b> Battery-less Absolute	<b>60</b> 60W <b>100</b> 100W <b>200</b> 200W <b>400</b> 400W	<b>2.5</b> 2.5mm <b>3</b> 3mm <b>4</b> 4mm <b>5</b> 5mm <b>6</b> 6mm <b>8</b> 8mm <b>10</b> 10mm <b>16</b> 16mm <b>20</b> 20mm <b>24</b> 24mm <b>30</b> 30mm	<b>60</b> 60mm ? ? <b>700</b> 700mm (50mm increments)	<b>T2</b> SCON MSCON SSEL XSEL-P/Q XSEL-RA/SA	<b>N</b> None <b>P</b> 1m <b>S</b> 3m <b>M</b> 5m <b>X</b> <input type="checkbox"/> Specified length (Standard cable) <b>R</b> <input type="checkbox"/> Robot cable	<b>B</b> Brake <b>CJT</b> Cable exit direction (Top) <b>CJR</b> Cable exit direction (Right) <b>CJL</b> Cable exit direction (Left) <b>CJO</b> Cable exit direction (Outside) <b>CJB</b> Cable exit direction (Bottom) <b>FL</b> Flange <b>FFA</b> Tip adapter (Flange) <b>NFA</b> Tip adapter (Internal thread) <b>KFA</b> Tip adapter (Keyway) <b>ML</b> Motor side-mounted to left (standard) <b>MR</b> Motor side-mounted to right <b>NM</b> Non-motor End Specification <b>RP</b> Back mounting plate <b>EU</b> Round cable joint connector
<b>RRA6C</b>	Body width 60mm Coupled motor type							
<b>RRA7C</b>	Body width 70mm Coupled motor type							
<b>RRA8C</b>	Body width 90mm Coupled motor type							
<b>RRA4R</b>	Body width 40mm Side-mounted motor type							
<b>RRA6R</b>	Body width 60mm Side-mounted motor type							
<b>RRA7R</b>	Body width 70mm Side-mounted motor type							
<b>RRA8R</b>	Body width 90mm Side-mounted motor type							

\*The type of motor, ball screw lead, stroke, and selection options vary depending on the actuator type. Please refer to the pages of each type for details.

Foreword  
Slider Type  
Wide Slider Type  
Rod Type  
Radial Cylinder  
Wide Radial Cylinder  
Table Type  
Cleanroom Slider  
Cleanroom Wide Slider  
Options  
Reference Data  
Controller

# Model Specification Items

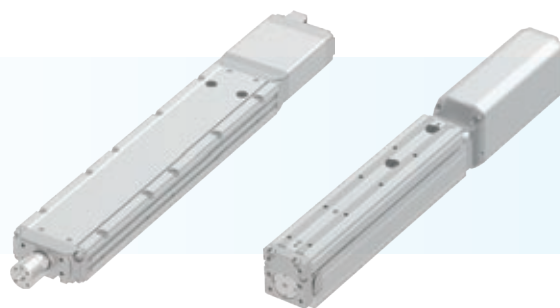

## Wide Radial Cylinder: WRA

**RCS4** — [ ] — **WA** — [ ] — [ ] — [ ] — [ ] — [ ] — [ ]

Series      Type      Encoder Type      Motor Type      Ball Screw Lead      Stroke      Applicable Controllers      Cable Length      Options

Encoder Type	Motor Type
<b>WA</b> Battery-less Absolute	
<b>60</b> 60W	
<b>100</b> 100W	
<b>200</b> 200W	
<b>400</b> 400W	

Ball Screw Lead	Stroke
<b>2.5</b> 2.5mm	<b>50</b> 50mm
<b>3</b> 3mm	?
<b>4</b> 4mm	?
<b>5</b> 5mm	<b>800</b> 800mm
<b>6</b> 6mm	(50mm increments)
<b>8</b> 8mm	
<b>10</b> 10mm	
<b>12</b> 12mm	
<b>16</b> 16mm	
<b>20</b> 20mm	
<b>24</b> 24mm	
<b>30</b> 30mm	

Applicable Controllers	Cable Length
<b>T2</b> SCON MSCON SSEL XSEL-P/Q XSEL-RA/SA	<b>N</b> None
	<b>P</b> 1m
	<b>S</b> 3m
	<b>M</b> 5m
	<input checked="" type="checkbox"/> Specified length (Standard cable)
	<input type="checkbox"/> Robot cable

Options
<b>B</b> Brake
<b>CJT</b> Cable exit direction (Top)
<b>CJR</b> Cable exit direction (Right)
<b>CJL</b> Cable exit direction (Left)
<b>CJO</b> Cable exit direction (Outside)
<b>CJB</b> Cable exit direction (Bottom)
<b>FL</b> Flange
<b>ML</b> Motor side-mounted to left (standard)
<b>MR</b> Motor side-mounted to right
<b>NM</b> Non-motor End Specification
<b>NTBL</b> T-slot nut bar (Left)
<b>NTBR</b> T-slot nut bar (Right)
<b>EU</b> Round cable joint connector

Type	Body width	Motor type
<b>WRA10C</b>	100mm	Coupled motor type
<b>WRA12C</b>	120mm	Coupled motor type
<b>WRA14C</b>	140mm	Coupled motor type
<b>WRA16C</b>	160mm	Coupled motor type
<b>WRA10R</b>	100mm	Side-mounted motor type
<b>WRA12R</b>	120mm	Side-mounted motor type
<b>WRA14R</b>	140mm	Side-mounted motor type
<b>WRA16R</b>	160mm	Side-mounted motor type

\*The type of motor, ball screw lead, stroke, and selection options vary depending on the actuator type. Please refer to the pages of each type for details.

## Table Type: TA

**RCS4** — [ ] — **WA** — [ ] — [ ] — [ ] — [ ] — [ ] — [ ]

Series      Type      Encoder Type      Motor Type      Ball Screw Lead      Stroke      Applicable Controllers      Cable Length      Options

Encoder Type	Motor Type
<b>WA</b> Battery-less Absolute	
<b>60</b> 60W	
<b>100</b> 100W	
<b>200</b> 200W	
<b>400</b> 400W	

Ball Screw Lead	Stroke
<b>2.5</b> 2.5mm	<b>25</b> 25mm
<b>3</b> 3mm	?
<b>4</b> 4mm	?
<b>5</b> 5mm	<b>390</b> 390mm
<b>6</b> 6mm	
<b>8</b> 8mm	
<b>10</b> 10mm	
<b>12</b> 12mm	
<b>16</b> 16mm	
<b>20</b> 20mm	
<b>24</b> 24mm	

Applicable Controllers	Cable Length
<b>T2</b> SCON MSCON SSEL XSEL-P/Q XSEL-RA/SA	<b>N</b> None
	<b>P</b> 1m
	<b>S</b> 3m
	<b>M</b> 5m
	<input checked="" type="checkbox"/> Specified length (Standard cable)
	<input type="checkbox"/> Robot cable

Options
<b>B</b> Brake
<b>CJT</b> Cable exit direction (Top)
<b>CJR</b> Cable exit direction (Right)
<b>CJL</b> Cable exit direction (Left)
<b>CJO</b> Cable exit direction (Outside)
<b>CJB</b> Cable exit direction (Bottom)
<b>DB</b> High Rigidity Specification (Double-block guide)
<b>ML</b> Motor side-mounted to left (standard)
<b>MR</b> Motor side-mounted to right
<b>NM</b> Non-motor End Specification
<b>RP</b> Back mounting plate
<b>EU</b> Round cable joint connector

Type	Body width	Motor type
<b>TA4C</b>	40mm	Coupled motor type
<b>TA6C</b>	60mm	Coupled motor type
<b>TA7C</b>	70mm	Coupled motor type
<b>TA4R</b>	40mm	Side-mounted motor type
<b>TA6R</b>	60mm	Side-mounted motor type
<b>TA7R</b>	70mm	Side-mounted motor type

\*The type of motor, ball screw lead, stroke, and selection options vary depending on the actuator type. Please refer to the pages of each type for details.

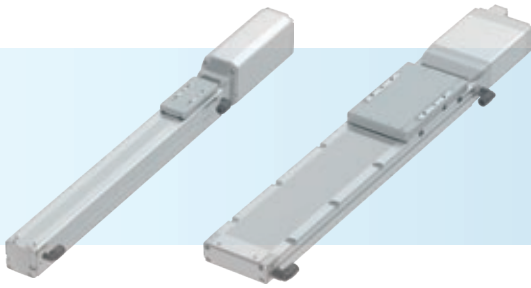

## Slider Type SA <Cleanroom Specification>

**RCS4CR** — [ ] — **WA** — [ ] — [ ] — [ ] — [ ] — [ ] — [ ]

Series      Type      Encoder Type      Motor Type      Ball Screw Lead      Stroke      Applicable Controllers      Cable Length      Options

<b>SA4C</b>	Body width 40mm Coupled motor type	<b>WA</b> Battery-less Absolute	<b>60</b> 60W	<b>50</b> 50mm ? ? <b>1100</b> 1100mm (50mm increments)	<b>T2</b> SCON MSCON SSEL XSEL-P/Q XSEL-RA/SA	<b>N</b> None <b>P</b> 1m <b>S</b> 3m <b>M</b> 5m <b>X</b> <input type="checkbox"/> Specified length (Standard cable) <b>R</b> <input type="checkbox"/> Robot cable	<b>B</b> Brake <b>CJT</b> Cable exit direction (Top) <b>CJR</b> Cable exit direction (Right) <b>CJL</b> Cable exit direction (Left) <b>CJB</b> Cable exit direction (Bottom) <b>HPR</b> High-precision Specification <b>NM</b> Non-motor End Specification <b>VR</b> Air suction joint in opposite position <b>W</b> Double Slider Specification <b>EU</b> Round cable joint connector
<b>SA6C</b>	Body width 60mm Coupled motor type		<b>100</b> 100W				
<b>SA7C</b>	Body width 70mm Coupled motor type		<b>200</b> 200W				
<b>SA8C</b>	Body width 90mm Coupled motor type		<b>400</b> 400W				

<b>2.5</b>	2.5mm
<b>3</b>	3mm
<b>4</b>	4mm
<b>5</b>	5mm
<b>6</b>	6mm
<b>8</b>	8mm
<b>10</b>	10mm
<b>12</b>	12mm
<b>16</b>	16mm
<b>20</b>	20mm
<b>24</b>	24mm

\*The type of motor, ball screw lead, stroke, and selection options vary depending on the actuator type. Please refer to the pages of each type for details.

## Wide Slider Type WSA <Cleanroom Specification>

**RCS4CR** — [ ] — **WA** — [ ] — [ ] — [ ] — [ ] — [ ] — [ ]

Series      Type      Encoder Type      Motor Type      Ball Screw Lead      Stroke      Applicable Controllers      Cable Length      Options

<b>WSA10C</b>	Body width 100mm Coupled motor type	<b>WA</b> Battery-less Absolute	<b>60</b> 60W	<b>50</b> 50mm ? ? <b>1100</b> 1100mm (50mm increments)	<b>T2</b> SCON MSCON SSEL XSEL-P/Q XSEL-RA/SA	<b>N</b> None <b>P</b> 1m <b>S</b> 3m <b>M</b> 5m <b>X</b> <input type="checkbox"/> Specified length (Standard cable) <b>R</b> <input type="checkbox"/> Robot cable	<b>B</b> Brake <b>CJT</b> Cable exit direction (Top) <b>CJR</b> Cable exit direction (Right) <b>CJL</b> Cable exit direction (Left) <b>CJB</b> Cable exit direction (Bottom) <b>HPR</b> High-precision Specification <b>NM</b> Non-motor End Specification <b>VR</b> Air suction joint in opposite position <b>EU</b> Round cable joint connector
<b>WSA12C</b>	Body width 120mm Coupled motor type		<b>100</b> 100W				
<b>WSA14C</b>	Body width 140mm Coupled motor type		<b>200</b> 200W				
<b>WSA16C</b>	Body width 160mm Coupled motor type		<b>400</b> 400W				

<b>2.5</b>	2.5mm
<b>3</b>	3mm
<b>4</b>	4mm
<b>5</b>	5mm
<b>6</b>	6mm
<b>8</b>	8mm
<b>10</b>	10mm
<b>12</b>	12mm
<b>16</b>	16mm
<b>20</b>	20mm
<b>24</b>	24mm

\*The type of motor, ball screw lead, stroke, and selection options vary depending on the actuator type. Please refer to the pages of each type for details.

Foreword  
Slider Type  
Wide Slider Type  
Rod Type  
Radial Cylinder  
Wide Radial Cylinder  
Table Type  
Cleanroom Slider  
Cleanroom Wide Slider  
Options  
Reference Data  
Controller

# RCS4-SA4C

±10μm  
Standard

±5μm  
Optional

Simple  
Dust-proof

Battery-less  
Absolute

Motor  
Unit  
Coupled

Straight  
Motor

Body Width  
**40  
mm**

**230v**  
AC Servo  
Motor

<b>Model Specification Items</b>	<b>RCS4</b>	<b>SA4C</b>	<b>WA</b>	<b>60</b>				<b>T2</b>		
	Series	Type	Encoder Type	Motor Type	Lead	Stroke	Applicable Controllers	Cable Length	Options	
			WA: Battery-less Absolute	60: Servo motor 60W	16: 16mm 10: 10mm 5: 5mm 2.5: 2.5mm	50: 50mm 500: 500mm (50mm increments)	T2: SCON MSCON SSEL XSEL-P/Q XSEL-RA/SA	N: None P: 1m S: 3m M: 5m X□□: Specified Length R□□: Robot Cable	Refer to Options table below.	

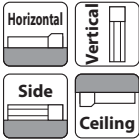

\* Depending on the model, there may be some limitations to using the vertical, side, and ceiling mount positions. Please refer to the Selection Notes on P.138 for more information.



- (1) Longer strokes may cause the maximum speed to decrease due to resonance of the ball screw. Be sure to check the maximum speed of the desired stroke in the Actuator Specifications table, which can be found below.
- (2) Both the horizontal and vertical payloads assume operation at an acceleration of 0.3G.
- (3) When the acceleration is increased, the payload will be reduced. Please refer to "Table of Payload by Acceleration" on P.139 for more details.
- (4) Estimated allowable duty varies depending on operating conditions (payload, acceleration/deceleration, etc.). Please refer to P. 149 for more information.

## Actuator Specifications

### Lead and Payload

Model Number	Motor wattage (W)	Lead (mm)	Max. payload		Rated thrust (N)	Stroke (mm)
			Horizontal (kg)	Vertical (kg)		
RCS4-SA4C-WA-60-16-①-T2-②-③	60	16	10	3	53	50~500 (50mm increments)
RCS4-SA4C-WA-60-10-①-T2-②-③		10	14	5	85	
RCS4-SA4C-WA-60-5-①-T2-②-③		5	17	8	170	
RCS4-SA4C-WA-60-2.5-①-T2-②-③		2.5	20	12	340	

Legend: ① Stroke ② Cable Length ③ Option

### Stroke and Max Speed (Unit: mm/s)

Lead	Stroke	Max Speed	
		50~450 (50mm increments)	500 (mm)
16		960	875
10		600	555
5		300	275
2.5		150	135

## Cable Length

Type	Cable Code
Standard	P (1m)
	S (3m)
	M (5m)
Specified length (Standard cable)	X06 (6m) ~ X10 (10m)
	X11 (11m) ~ X15 (15m)
	X16 (16m) ~ X20 (20m)
	R01 (1m) ~ R03 (3m)
Robot cable	R04 (4m) ~ R05 (5m)
	R06 (6m) ~ R10 (10m)
	R11 (11m) ~ R15 (15m)
	R16 (16m) ~ R20 (20m)

## Options

Name	Option Code	Reference Page
Brake	B	See P.131
Cable exit direction (Top)	CJT	See P.131
Cable exit direction (Right)	CJR	See P.131
Cable exit direction (Left)	CJL	See P.131
Cable exit direction (Bottom)	CJB	See P.131
High-Precision specification (*1)	HPR	See P.134
Non-motor end specification	NM	See P.136
Slider roller specification	SR	See P.137
Double slider (*2)	W	See P.137

## Actuator Specifications

Item	Description
Drive system	Ball screw ø8mm, rolled C10
Positioning repeatability (*1)	±0.01mm [±0.005mm]
Lost motion	0.1mm or less
Base	Material: Aluminum with white alumite treatment
Allowable static moment	Ma direction: 13.0N·m, Mb direction: 18.6N·m, Mc direction: 25.3N·m
Allowable dynamic moment (*2)	Ma direction: 5.0N·m, Mb direction: 7.1N·m, Mc direction: 9.7N·m
Ambient operating temp. & humidity	0~40°C, 85% RH or less (Non-condensing)

(\*1) Values in [ ] are for high-precision specification.  
 (\*2) Assumes a standard rated life of 5000km. The service life will vary depending on operation and installation conditions. Please contact IAI for details of the running life.

• Reference for overhang load length: Ma: 150mm or less, Mb, Mc: 150mm or less

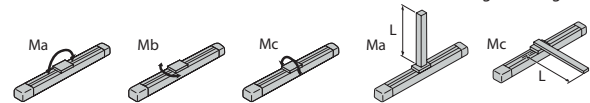

If the load moments in Ma/Mb/Mc direction are within the allowable ranges, there is no overhang load length limit.

Round cable joint connector with screw locking (*3)	<b>EU</b>	See P.131
---	-----------	-----------

(\*1) Double slider cannot be selected. (\*2) Some leads cannot be selected. (Please see P. 150) (\*3) EU option will be available soon.

## Dimensions

CAD drawings can be downloaded from our website.  
[www.robocylinder.de](http://www.robocylinder.de)



\*1 When the slider is returning to its home position, please be careful of interference from surrounding objects, as it will travel until it reaches the M.E.  
 M.E: Mechanical end S.E: Stroke end

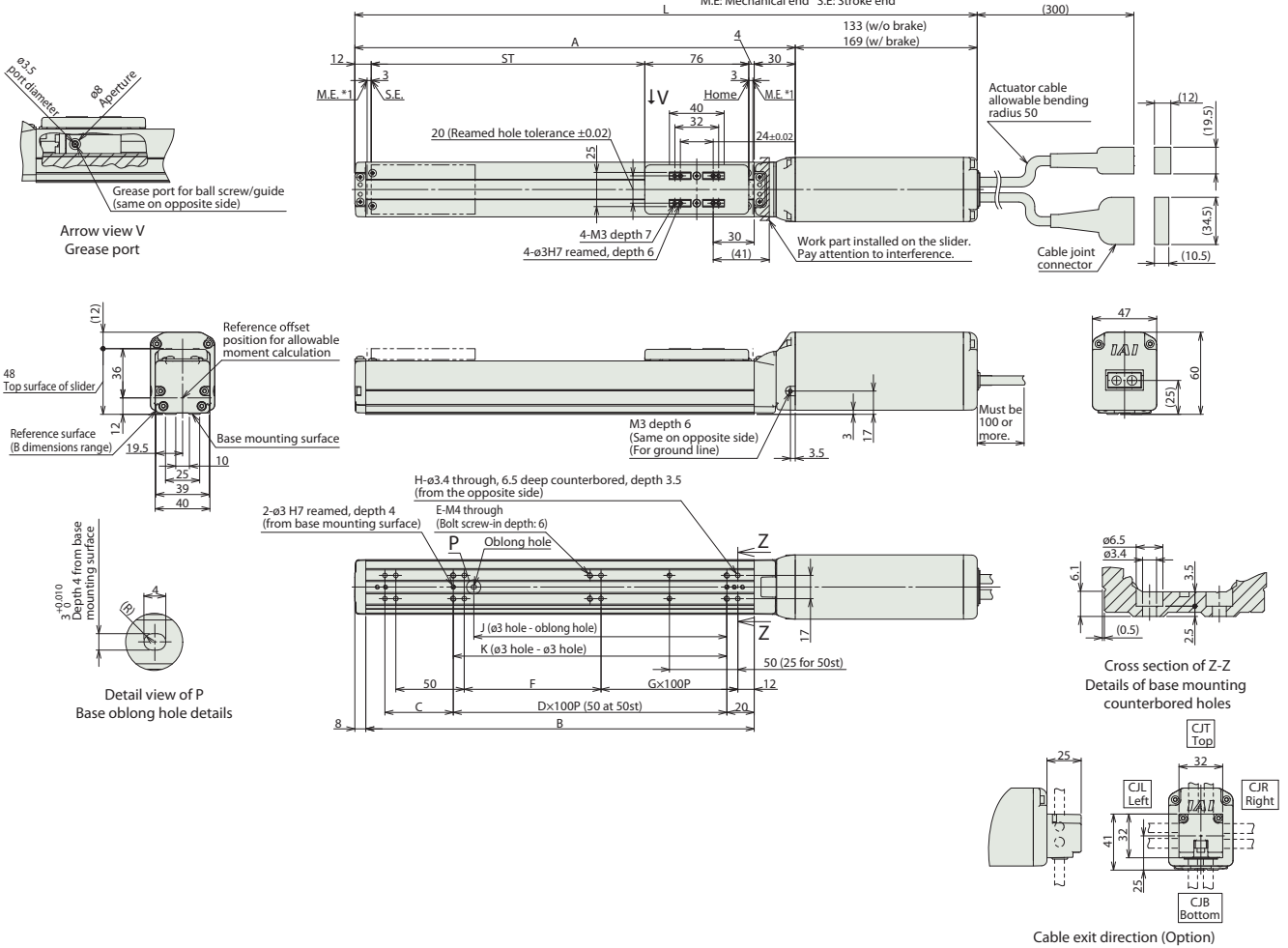

## Dimensions and Mass by Stroke

L	Stroke	50	100	150	200	250	300	350	400	450	500
	W/o brake	305	355	405	455	505	555	605	655	705	755
W/ brake	341	391	441	491	541	591	641	691	741	791	
A	172	222	272	322	372	422	472	522	572	622	
B	134	184	234	284	334	384	434	484	534	584	
C	50	50	100	50	100	50	100	50	100	50	
D	-	1	1	2	2	3	3	4	4	5	
E	6	6	6	8	8	10	10	12	12	14	
F	50	100	50	100	50	100	50	100	50	100	
G	0	0	1	1	2	2	3	3	4	4	
H	8	8	10	10	12	12	14	14	16	16	
J	35	85	85	185	185	285	285	385	385	485	
K	50	100	100	200	200	300	300	400	400	500	
Mass (kg)	W/o brake	1.2	1.3	1.4	1.5	1.5	1.6	1.7	1.8	1.9	2.0
	W/ brake	1.4	1.5	1.6	1.7	1.7	1.8	1.9	2.0	2.1	2.2

## Applicable Controllers

The RCS4 series actuators can be operated by the controllers indicated below. Please select the type depending on your intended use.

Name	External view	Max. number of connectable axes	Input power	Control method				Maximum number of positioning points	Reference page	
				Positioner	Pulse train	Program	Network * Option			
SCON-CB/CGB		1	Single phase 115V/230VAC	●	●	-	DeviceNet CC-Link PROFINET CompoNet EtherCAT EtherNet/IP	512 (768 for network spec.)	Please see the dedicated controller catalog or manual.	
SCON-LC/LCG (*)		1		-	-	●		512 (768 for network spec.)		
SCON-CAL/CGAL		1		●	-	-		512 (768 for network spec.)		
MSCON-C		6		This model is network-compatible only.				256		
SSEL-CS		2		●	-	●		20000		
XSEL-P/Q or XSEL-RA/SA (*)		6 or 8 (Depending on the type)		Single phase 230VAC Three-phase 230VAC	-	-		●		20000 or 55000 (Depending on the type)

Note: The type of compatible networks will vary depending on the controller. Please refer to the reference page for more information.

(\*) Coming soon

Foreword  
 Slider Type  
 Wide Slider Type  
 Rod Type  
 Radial Cylinder  
 Wide Radial Cylinder  
 Table Type  
 Cleanroom Slider  
 Cleanroom Wide Slider  
 Options  
 Reference Data  
 Controller

# RCS4-SA6C

±10μm  
Standard

±5μm  
Optional

Simple  
Dust-  
proof

Battery-  
less  
Absolute

Motor  
Unit  
Coupled

Straight  
Motor

Body Width  
**60  
mm**

**230v**  
AC Servo  
Motor

<b>Model Specification Items</b>	<b>RCS4</b> — <b>SA6C</b> — <b>WA</b> — <b>100</b> — [ ] — [ ] — [ ] — [ ]	<b>Series</b> — <b>Type</b> — <b>Encoder Type</b> — <b>Motor Type</b> — <b>Lead</b> — <b>Stroke</b> — <b>Applicable Controllers</b> — <b>Cable Length</b> — <b>Options</b>
	WA: Battery-less Absolute      100: Servo motor 100W      30:30mm 20:20mm 12:12mm 6: 6mm 3: 3mm      50:50mm 800:800mm (50mm increments)      T2:SCON MSCON SSEL XSEL-P/Q XSEL-RA/SA      N : None P : 1m S : 3m M : 5m X□□ : Specified Length R□□ : Robot Cable      Refer to Options table below.	

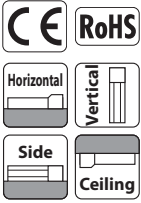

\* Depending on the model, there may be some limitations to using the vertical, side, and ceiling mount positions. Please refer to the Selection Notes on P.138 for more information.



POINT Selection Notes

- (1) Longer strokes may cause the maximum speed to decrease due to resonance of the ball screw. Be sure to check the maximum speed of the desired stroke in the Actuator Specifications table, which can be found below.
- (2) Both the horizontal and vertical payloads assume operation at an acceleration of 0.3G.
- (3) When the acceleration is increased, the payload will be reduced. Please refer to "Table of Payload by Acceleration" on P.139 for more details.
- (4) Estimated allowable duty varies depending on operating conditions (payload, acceleration/deceleration, etc.). Please refer to P. 149 for more information.

## Actuator Specifications

### Lead and Payload

Model Number	Motor wattage (W)	Lead (mm)	Max. payload	Rated thrust (N)	Stroke (mm)	
			Horizontal (kg)	Vertical (kg)		
RCS4-SA6C-WA-100-30-①-T2-②-③	100	30	11	3.5	50~800 (50mm increments)	
RCS4-SA6C-WA-100-20-①-T2-②-③		20	18	6		85
RCS4-SA6C-WA-100-12-①-T2-②-③		12	30	11		142
RCS4-SA6C-WA-100-6-①-T2-②-③		6	45	15		283
RCS4-SA6C-WA-100-3-①-T2-②-③		3	45	15		566

Legend: ① Stroke ② Cable Length ③ Option

### Stroke and Max Speed

(Unit: mm/s)

Stroke / Lead	50~500 (50mm increments)	550 (mm)	600 (mm)	650 (mm)	700 (mm)	750 (mm)	800 (mm)
	30	1600	1450	1260	1100	970	860
20	1200	1130	970	840	735	650	575
12	720	620	535	460	405	355	315
6	360	305	265	230	200	175	155
3	180	150	130	115	100	85	75

## Cable Length

Type	Cable Code
Standard	<b>P</b> (1m)
	<b>S</b> (3m)
	<b>M</b> (5m)
Specified length (Standard cable)	<b>X06</b> (6m) ~ <b>X10</b> (10m)
	<b>X11</b> (11m) ~ <b>X15</b> (15m)
	<b>X16</b> (16m) ~ <b>X20</b> (20m)
	<b>R01</b> (1m) ~ <b>R03</b> (3m)
Robot cable	<b>R04</b> (4m) ~ <b>R05</b> (5m)
	<b>R06</b> (6m) ~ <b>R10</b> (10m)
	<b>R11</b> (11m) ~ <b>R15</b> (15m)
	<b>R16</b> (16m) ~ <b>R20</b> (20m)

## Options

Name	Option Code	Reference Page
Brake	<b>B</b>	See P.131
Cable exit direction (Top)	<b>CJT</b>	See P.131
Cable exit direction (Right)	<b>CJR</b>	See P.131
Cable exit direction (Left)	<b>CJL</b>	See P.131
Cable exit direction (Bottom)	<b>CJB</b>	See P.131
High-Precision specification (*1)	<b>HPR</b>	See P.134
Non-motor end specification	<b>NM</b>	See P.136
Slider roller specification	<b>SR</b>	See P.137
Double slider (*2)	<b>W</b>	See P.137

(\*1) When the lead is 30, it cannot be selected. Double slider cannot be selected. (\*2) Some leads cannot be selected. (Please see P. 150)  
(\*3) EU option will be available soon.

## Actuator Specifications

Item	Description
Drive system	Ball screw ø10mm, rolled C10
Positioning repeatability (*1)	±0.01mm [±0.005mm]
Lost motion	0.1mm or less
Base	Material: Aluminum with white alumite treatment
Allowable static moment	Ma direction: 48.5N·m, Mb direction: 69.3N·m, Mc direction: 103N·m
Allowable dynamic moment (*2)	Ma direction: 11.6N·m, Mb direction: 16.6N·m, Mc direction: 24.6N·m
Ambient operating temp. & humidity	0~40°C, 85% RH or less (Non-condensing)

(\*1) Values in [ ] are for high-precision (for lead 3/6/12/20) specification.  
(\*2) Assumes a standard rated life of 5000km. The service life will vary depending on operation and installation conditions. Please contact IAI for details of the running life.

• Reference for overhang load length: Ma: 220mm or less, Mb, Mc: 220mm or less  
Allowable load moment directions      Overhang load lengths

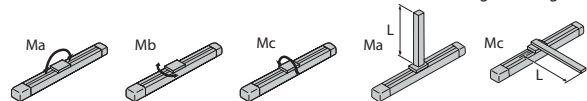

If the load moments in Ma/Mb/Mc direction are within the allowable ranges, there is no overhang load length limit.

Round cable joint connector with screw locking (*3)	<b>EU</b>	See P.131
---	-----------	-----------

## Dimensions

CAD drawings can be downloaded from our website.  
www.robocylinder.de



\*1 When the slider is returning to its home position, please be careful of interference from surrounding objects, as it will travel until it reaches the M.E.  
M.E: Mechanical end S.E: Stroke end

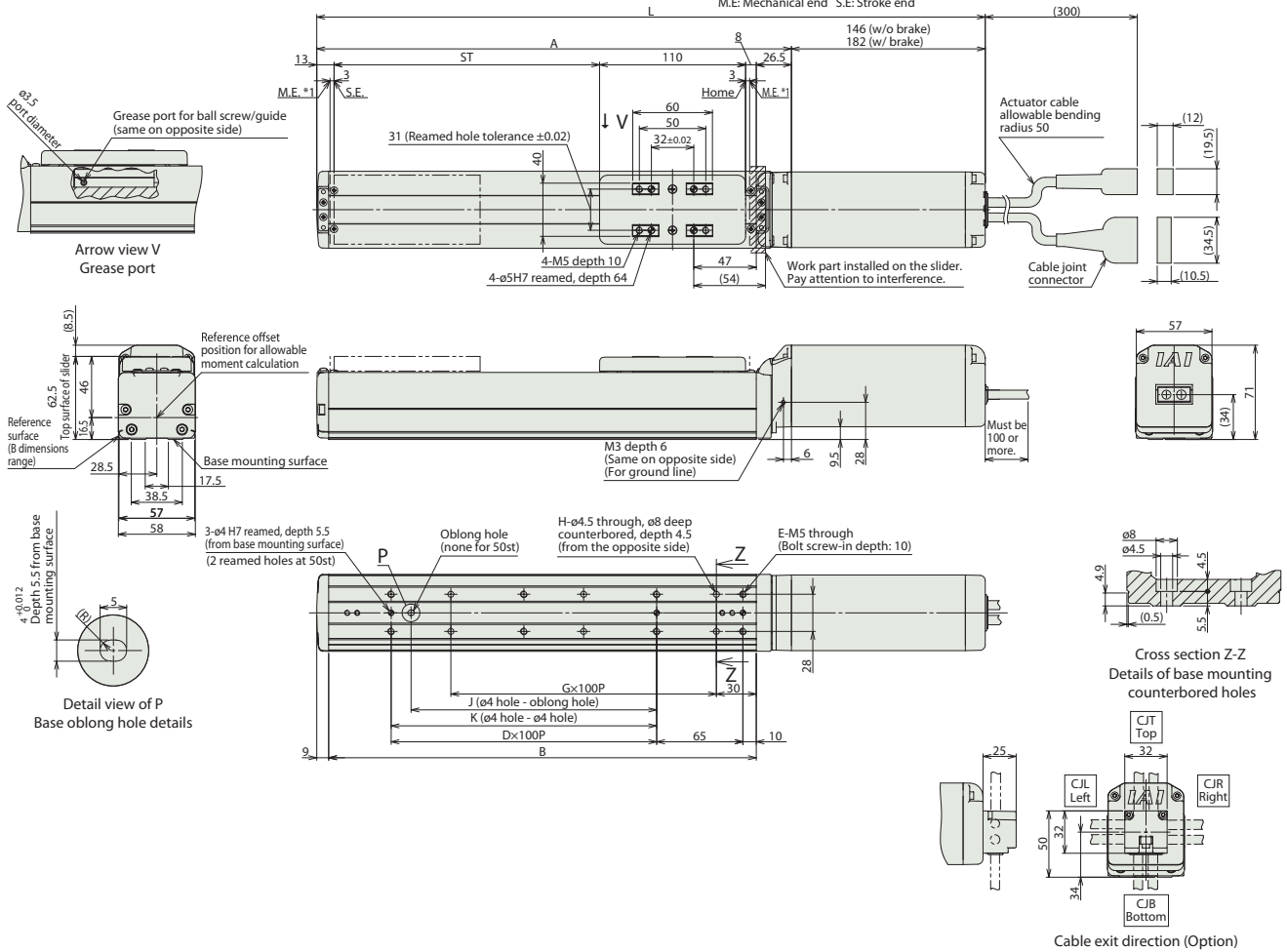

## Dimensions and Mass by Stroke

L	Stroke	50	100	150	200	250	300	350	400	450	500	550	600	650	700	750	800
	W/o brake	353.5	403.5	453.5	503.5	553.5	603.5	653.5	703.5	753.5	803.5	853.5	903.5	953.5	1003.5	1053.5	1103.5
W/ brake	389.5	439.5	489.5	539.5	589.5	639.5	689.5	739.5	789.5	839.5	889.5	939.5	989.5	1039.5	1089.5	1139.5	
A	207.5	257.5	307.5	357.5	407.5	457.5	507.5	557.5	607.5	657.5	707.5	757.5	807.5	857.5	907.5	957.5	
B	172	222	272	322	372	422	472	522	572	622	672	722	772	822	872	922	
D	0	1	1	2	2	3	3	4	4	5	5	6	6	7	7	8	
E	4	6	6	8	8	10	10	12	12	14	14	16	16	18	18	20	
G	1	1	2	2	3	3	4	4	5	5	6	6	7	7	8	8	
H	4	4	6	6	8	8	10	10	12	12	14	14	16	16	18	18	
J	0	85	85	185	185	285	285	385	385	485	485	585	585	685	685	785	
K	0	100	100	200	200	300	300	400	400	500	500	600	600	700	700	800	
Mass (kg)	W/o brake	2.0	2.2	2.4	2.6	2.7	2.9	3.1	3.3	3.4	3.6	3.8	4.0	4.2	4.3	4.5	4.7
	W/ brake	2.3	2.5	2.7	2.9	3.0	3.2	3.4	3.6	3.7	3.9	4.1	4.3	4.5	4.6	4.8	5.0

## Applicable Controllers

The RCS4 series actuators can be operated by the controllers indicated below. Please select the type depending on your intended use.

Name	External view	Max. number of connectable axes	Input power	Control method				Maximum number of positioning points	Reference page	
				Positioner	Pulse train	Program	Network + Option			
SCON-CB/CGB		1	Single phase 115V/230VAC	●	●	—	DeviceNet CC-Link CompoNet EtherCAT EtherNet/IP Note: The type of compatible networks will vary depending on the controller. Please refer to the reference page for more information.	512 (768 for network spec.)	Please see the dedicated controller catalog or manual.	
SCON-LC/LCG (*)		1		—	—	●		512 (768 for network spec.)		
SCON-CAL/CGAL		1		●	—	—		512 (768 for network spec.)		
MSCON-C		6		This model is network-compatible only.				256		
SSEL-CS		2		●	—	●		20000		
XSEL-P/Q or XSEL-RA/SA (*)		6 or 8 (Depending on the type)	Single phase 230VAC Three-phase 230VAC	—	—	●	20000 or 55000 (Depending on the type)			

(\*) Coming soon

Foreword  
Slider Type  
Wide Slider Type  
Rod Type  
Radial Cylinder  
Wide Radial Cylinder  
Table Type  
Cleanroom Slider  
Cleanroom Wide Slider  
Options  
Reference Data  
Controller

# RCS4-SA7C

$\pm 10\mu\text{m}$ Standard	$\pm 5\mu\text{m}$ Optional	Simple Dust- proof	Battery- less Absolute	Motor Unit Coupled	Straight Motor	Body Width <b>70 mm</b>	<b>230v</b> AC Servo Motor
---------------------------------	--------------------------------	--------------------------	------------------------------	--------------------------	-------------------	--------------------------------	----------------------------------

Model Specification Items	<b>RCS4</b> — <b>SA7C</b> — <b>WA</b> — <b>200</b> — [ ] — [ ] — [ ] — [ ] — [ ]
	Series — Type — Encoder Type — Motor Type — Lead — Stroke — Applicable Controllers — Cable Length — Options
	WA: Battery-less Absolute      200: Servo motor 200W      36:36mm 24:24mm 16:16mm 8: 8mm 4: 4mm      50:50mm 800:800mm (50mm increments)      T2:SCON MSCON SSEL XSEL-P/Q XSEL-RA/SA      N : None P : 1m S : 3m M : 5m X□□ : Specified Length R□□ : Robot Cable      Refer to Options table below.

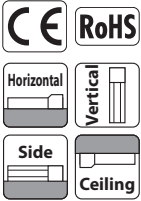

\* Depending on the model, there may be some limitations to using the vertical, side, and ceiling mount positions. Please refer to the Selection Notes on P.138 for more information.



- (1) Longer strokes may cause the maximum speed to decrease due to resonance of the ball screw. Be sure to check the maximum speed of the desired stroke in the Actuator Specifications table, which can be found below.
- (2) Both the horizontal and vertical payloads assume operation at an acceleration of 0.3G.
- (3) When the acceleration is increased, the payload will be reduced. Please refer to "Table of Payload by Acceleration" on P.139 for more details.
- (4) Estimated allowable duty varies depending on operating conditions (payload, acceleration/deceleration, etc.). Please refer to P. 149 for more information.

## Actuator Specifications

### Lead and Payload

Model Number	Motor wattage (W)	Lead (mm)	Max. payload (kg)	Rated thrust (N)	Stroke (mm)
RCS4-SA7C-WA-200-36-①-T2-②-③	200	36	7	4	50-800 (50mm increments)
RCS4-SA7C-WA-200-24-①-T2-②-③		24	30	7	
RCS4-SA7C-WA-200-16-①-T2-②-③		16	40	12	
RCS4-SA7C-WA-200-8-①-T2-②-③		8	45	20	
RCS4-SA7C-WA-200-4-①-T2-②-③		4	50	25	

Legend: ① Stroke ② Cable Length ③ Option

### Stroke and Max Speed

(Unit: mm/s)

Stroke / Lead	Stroke (mm)						
	50-500 (50mm increments)	550 (mm)	600 (mm)	650 (mm)	700 (mm)	750 (mm)	800 (mm)
36	1800			1620	1420	1260	1120
24	1500	1440	1240	1095	965	850	760
16	1000	965	830	720	635	560	500
8	500	475	410	355	315	275	245
4	240	235	205	175	155	135	120

## Cable Length

Type	Cable Code
Standard	<b>P</b> (1m)
	<b>S</b> (3m)
	<b>M</b> (5m)
Specified length (Standard cable)	<b>X06</b> (6m) ~ <b>X10</b> (10m)
	<b>X11</b> (11m) ~ <b>X15</b> (15m)
	<b>X16</b> (16m) ~ <b>X20</b> (20m)
Robot cable	<b>R01</b> (1m) ~ <b>R03</b> (3m)
	<b>R04</b> (4m) ~ <b>R05</b> (5m)
	<b>R06</b> (6m) ~ <b>R10</b> (10m)
	<b>R11</b> (11m) ~ <b>R15</b> (15m)
	<b>R16</b> (16m) ~ <b>R20</b> (20m)

## Options

Name	Option Code	Reference Page
Brake	<b>B</b>	See P.131
Cable exit direction (Top)	<b>CJT</b>	See P.131
Cable exit direction (Right)	<b>CJR</b>	See P.131
Cable exit direction (Left)	<b>CJL</b>	See P.131
Cable exit direction (Bottom)	<b>CJB</b>	See P.131
High-Precision specification (*1)	<b>HPR</b>	See P.134
Non-motor end specification	<b>NM</b>	See P.136
Slider roller specification	<b>SR</b>	See P.137
Double slider (*2)	<b>W</b>	See P.137

(\*1) When the lead is 24/36, it cannot be selected. Double slider cannot be selected. (\*2) Some leads cannot be selected. (Please see P. 150)  
(\*3) EU option will be available soon.

## Actuator Specifications

Item	Description
Drive system	Ball screw $\phi 12\text{mm}$ , rolled C10
Positioning repeatability (*1)	$\pm 0.01\text{mm}$ [ $\pm 0.005\text{mm}$ ]
Lost motion	0.1mm or less
Base	Material: Aluminum with white alumite treatment
Allowable static moment	Ma direction 115N·m, Mb direction 115N·m, Mc direction 229N·m
Allowable dynamic moment (*2)	Ma direction 44.7N·m, Mb direction 44.7N·m, Mc direction 89.1N·m
Ambient operating temp. & humidity	0~40°C, 85% RH or less (Non-condensing)

(\*1) Values in [ ] are for high-precision (for lead 4/8/16) specification.  
(\*2) Assumes a standard rated life of 5000km. The service life will vary depending on operation and installation conditions. Please contact IAI for details of the running life.

- Reference for overhang load length: Ma: 300mm or less, Mb, Mc: 300mm or less

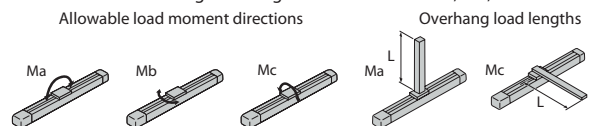

If the load moments in Ma/Mb/Mc direction are within the allowable ranges, there is no overhang load length limit.

Round cable joint connector with screw locking (*3)	<b>EU</b>	See P.131
---	-----------	-----------



## Dimensions

CAD drawings can be downloaded from our website.  
www.robocylinder.de



\*1 When the slider is returning to its home position, please be careful of interference from surrounding objects, as it will travel until it reaches the M.E.  
M.E: Mechanical end S.E: Stroke end

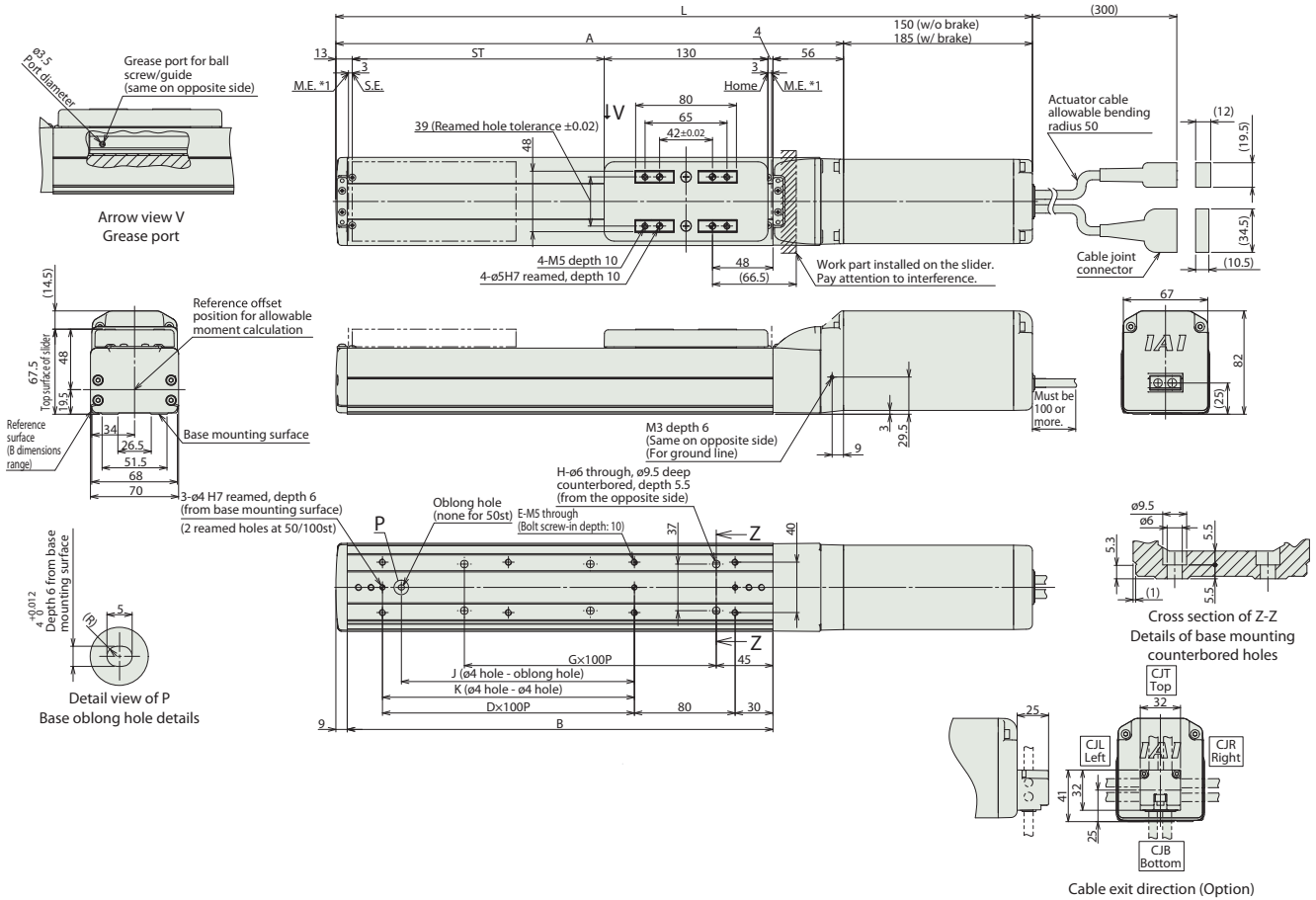

## Dimensions and Mass by Stroke

L	Stroke	50	100	150	200	250	300	350	400	450	500	550	600	650	700	750	800
	W/o brake	403	453	503	553	603	653	703	753	803	853	903	953	1003	1053	1103	1153
W/ brake	438	488	538	588	638	688	738	788	838	888	938	988	1038	1088	1138	1188	
A	253	303	353	403	453	503	553	603	653	703	753	803	853	903	953	1003	
B	188	238	288	338	388	438	488	538	588	638	688	738	788	838	888	938	
D	0	1	1	2	2	3	3	4	4	5	5	6	6	7	7	8	
E	4	6	6	8	8	10	10	12	12	14	14	16	16	18	18	20	
G	1	1	2	2	3	3	4	4	5	5	6	6	7	7	8	8	
H	4	4	6	6	8	8	10	10	12	12	14	14	16	16	18	18	
J	0	85	85	185	185	285	285	385	385	485	485	585	585	685	685	785	
K	0	0	100	200	200	300	300	400	400	500	500	600	600	700	700	800	
Mass (kg)	W/o brake	3.5	3.8	4.0	4.3	4.5	4.7	5.0	5.2	5.4	5.7	5.9	6.1	6.4	6.6	6.8	7.1
	W/ brake	4.0	4.3	4.5	4.8	5.0	5.2	5.5	5.7	5.9	6.2	6.4	6.6	6.9	7.1	7.3	7.6

## Applicable Controllers

The RCS4 series actuators can be operated by the controllers indicated below. Please select the type depending on your intended use.

Name	External view	Max. number of connectable axes	Input power	Control method				Maximum number of positioning points	Reference page	
				Positioner	Pulse train	Program	Network * Option			
SCON-CB/CGB		1	Single phase 115V/230VAC	●	●	—	DeviceNet CClink Profinet Compovet EtherCAT EtherNet/IP	512 (768 for network spec.)	Please see the dedicated controller catalog or manual.	
SCON-LC/LCG (*)		1		—	—	●		512 (768 for network spec.)		
SCON-CAL/CGAL		1		●	—	—		512 (768 for network spec.)		
MSCON-C		6		This model is network-compatible only.				256		
SSEL-CS		2		●	—	●		20000		
XSEL-P/Q or XSEL-RA/SA (*)		6 or 8 (Depending on the type)	Single phase 230VAC Three-phase 230VAC	—	—	●	20000 or 55000 (Depending on the type)			

(\*) Coming soon

Foreword  
Slider Type  
Wide Slider Type  
Rod Type  
Radial Cylinder  
Wide Radial Cylinder  
Table Type  
Cleanroom Slider  
Cleanroom Wide Slider  
Options  
Reference Data  
Controller

# RCS4-SA8C

$\pm 10\mu\text{m}$ Standard	$\pm 5\mu\text{m}$ Optional	Simple Dust- proof	Battery- less Absolute	Motor Unit Coupled	Straight Motor	Body Width <b>90 mm</b>	<b>230v</b> AC Servo Motor
---------------------------------	--------------------------------	--------------------------	------------------------------	--------------------------	-------------------	--------------------------------	----------------------------------

Model Specification Items	<b>RCS4</b> — <b>SA8C</b> — <b>WA</b> — <b>400</b> — [ ] — [ ] — [ ] — [ ] — [ ]
	Series — Type — Encoder Type — Motor Type — Lead — Stroke — Applicable Controllers — Cable Length — Options
	WA: Battery-less Absolute      400: Servo motor 400W      48:48mm 30:30mm 20:20mm 10:10mm 5: 5mm      50:50mm 1100:1100mm (50mm increments)      T2:SCON SSEL XSEL-P/Q XSEL-RA/SA      N : None P : 1m S : 3m M : 5m      Refer to Options table below.      X□□ : Specified Length R□□ : Robot Cable

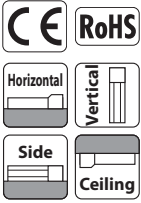

\* Depending on the model, there may be some limitations to using the vertical, side, and ceiling mount positions. Please refer to the Selection Notes on P.138 for more information.



- (1) Longer strokes may cause the maximum speed to decrease due to resonance of the ball screw. Be sure to check the maximum speed of the desired stroke in the Actuator Specifications table, which can be found below.
- (2) Both the horizontal and vertical payloads assume operation at an acceleration of 0.3G.
- (3) When the acceleration is increased, the payload will be reduced. Please refer to "Table of Payload by Acceleration" on P.139 for more details.
- (4) Estimated allowable duty varies depending on operating conditions (payload, acceleration/deceleration, etc.). Please refer to P. 149 for more information.

## Actuator Specifications

### Lead and Payload

Model Number	Motor wattage (W)	Lead (mm)		Rated thrust (N)	Stroke (mm)
		Horizontal (kg)	Vertical (kg)		
RCS4-SA8C-WA-400-48-①-T2-②-③	400	48	8	141	50~1100 (50mm increments)
RCS4-SA8C-WA-400-30-①-T2-②-③		30	30	226	
RCS4-SA8C-WA-400-20-①-T2-②-③		20	60	339	
RCS4-SA8C-WA-400-10-①-T2-②-③		10	80	678	
RCS4-SA8C-WA-400-5-①-T2-②-③		5	90	1357	

Legend: ① Stroke ② Cable Length ③ Option

### Stroke and Max Speed

(Unit: mm/s)

Stroke	Lead										
	50-600 (50mm increments)	650 (mm)	700 (mm)	750 (mm)	800 (mm)	850 (mm)	900 (mm)	950 (mm)	1000 (mm)	1050 (mm)	1100 (mm)
48	2200			2180	1950	1760	1590	1450	1320	1210	1110
30	1800	1640	1440	1280	1155	1040	940	855	780	715	660
20	1200	1090	960	860	770	695	630	570	520	480	440
10	600	540	480	430	385	345	310	285	260	235	220
5	300	270	240	215	190	175	155	140	130	120	110

## Cable Length

Type	Cable Code
Standard	P (1m)
	S (3m)
	M (5m)
Specified length (Standard cable)	X06 (6m) ~ X10 (10m)
	X11 (11m) ~ X15 (15m)
	X16 (16m) ~ X20 (20m)
Robot cable	R01 (1m) ~ R03 (3m)
	R04 (4m) ~ R05 (5m)
	R06 (6m) ~ R10 (10m)
	R11 (11m) ~ R15 (15m)
	R16 (16m) ~ R20 (20m)

## Actuator Specifications

Item	Description
Drive system	Ball screw $\phi 16\text{mm}$ , rolled C10
Positioning repeatability (*1)	$\pm 0.01\text{mm}$ [ $\pm 0.005\text{mm}$ ]
Lost motion	0.1mm or less
Base	Material: Aluminum with white alumite treatment
Allowable static moment	Ma direction 219N·m, Mb direction 219N·m, Mc direction 414N·m
Allowable dynamic moment (*2)	Ma direction 77.0N·m, Mb direction 77.0N·m, Mc direction 146N·m
Ambient operating temp. & humidity	0~40°C, 85% RH or less (Non-condensing)

(\*1) Values in [ ] are for high-precision (for lead 5/10/20) specification.  
 (\*2) Assumes a standard rated life of 5000km. The service life will vary depending on operation and installation conditions. Please contact IAI for details of the running life.

- Reference for overhang load length: Ma: 400mm or less, Mb, Mc: 400mm or less

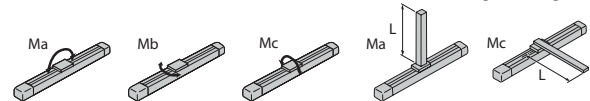

If the load moments in Ma/Mb/Mc direction are within the allowable ranges, there is no overhang load length limit.

Round cable joint connector with screw locking (*3)	<b>EU</b>	See P.131
---	-----------	-----------

## Options

Name	Option Code	Reference Page
Brake	<b>B</b>	See P.131
Cable exit direction (Top)	<b>CJT</b>	See P.131
Cable exit direction (Right)	<b>CJR</b>	See P.131
Cable exit direction (Left)	<b>CJL</b>	See P.131
Cable exit direction (Bottom)	<b>CJB</b>	See P.131
High-Precision specification (*1)	<b>HPR</b>	See P.134
Non-motor end specification	<b>NM</b>	See P.136
Slider roller specification	<b>SR</b>	See P.137
Double slider (*2)	<b>W</b>	See P.137

(\*1) When the lead is 30/48, it cannot be selected. Double slider cannot be selected. (\*2) Some leads cannot be selected. (Please see P. 150)

(\*3) EU option will be available soon.

## Dimensions

CAD drawings can be downloaded from our website.  
www.robocylinder.de



\*1 When the slider is returning to its home position, please be careful of interference from surrounding objects, as it will travel until it reaches the M.E.  
M.E: Mechanical end S.E: Stroke end

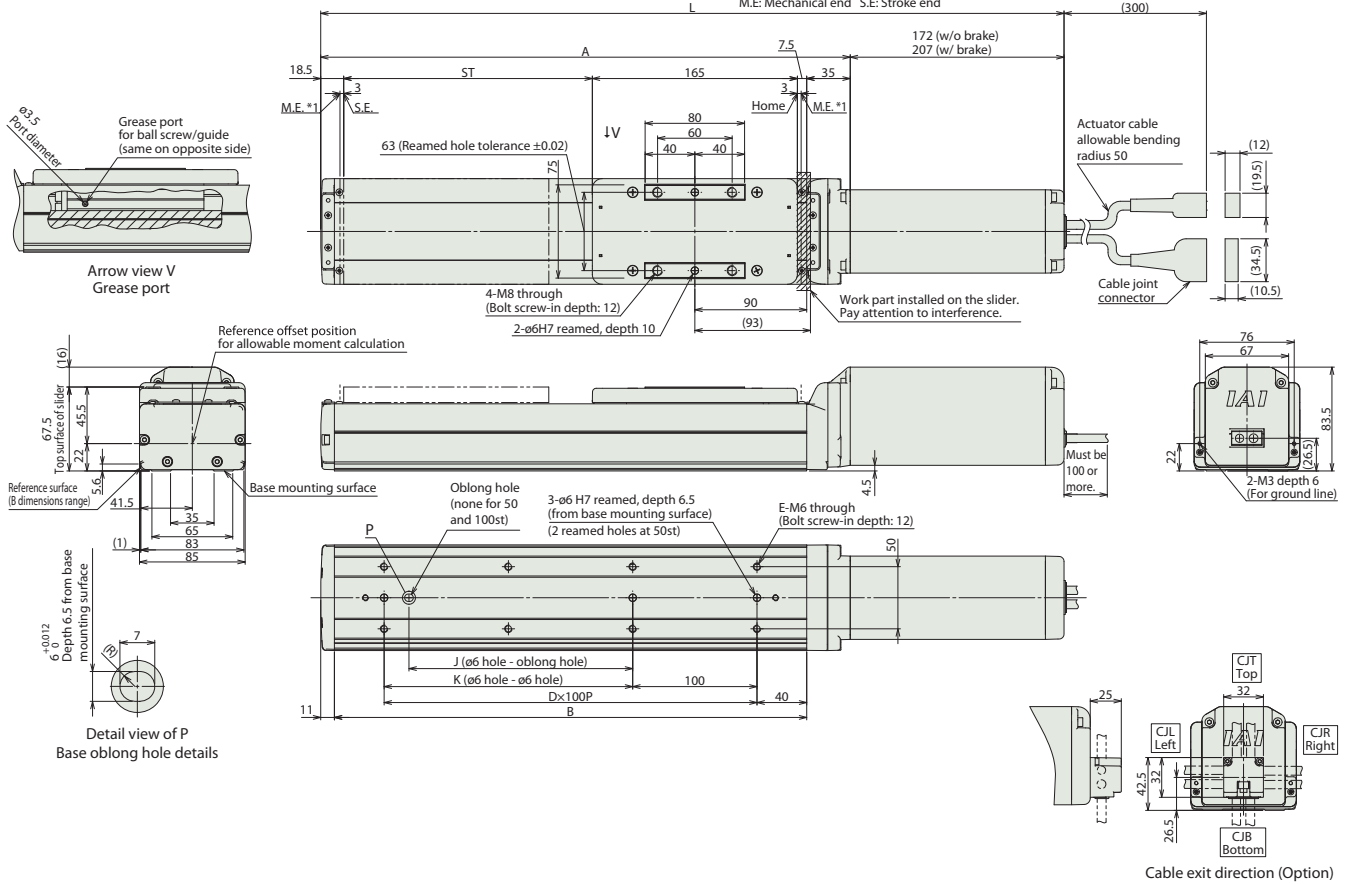

## Dimensions and Mass by Stroke

L	Stroke	50	100	150	200	250	300	350	400	450	500	550	600	650	700	750	800	850	900	950	1000	1050	1100
	W/o brake	448	498	548	598	648	698	748	798	848	898	948	998	1048	1098	1148	1198	1248	1298	1348	1398	1448	1498
W/ brake	483	533	583	633	683	733	783	833	883	933	983	1033	1083	1133	1183	1233	1283	1333	1383	1433	1483	1533	
A	276	326	376	426	476	526	576	626	676	726	776	826	876	926	976	1026	1076	1126	1176	1226	1276	1326	
B	230	280	330	380	430	480	530	580	630	680	730	780	830	880	930	980	1030	1080	1130	1180	1230	1280	
D	1	2	2	3	3	4	4	5	5	6	6	7	7	8	8	9	9	10	10	11	11	12	
E	4	6	6	8	8	10	10	12	12	14	14	16	16	18	18	20	20	22	22	24	24	26	
J	0	0	80	180	180	280	280	380	380	480	480	580	580	680	680	780	780	880	880	980	980	1080	
K	0	100	100	200	200	300	300	400	400	500	500	600	600	700	700	800	800	900	900	1000	1000	1100	
Mass (kg)	W/o brake	4.7	5.0	5.3	5.6	5.9	6.2	6.5	6.8	7.1	7.4	7.6	7.9	8.2	8.5	8.8	9.1	9.4	9.7	10.0	10.3	10.6	10.8
	W/ brake	5.2	5.5	5.8	6.1	6.4	6.7	7.0	7.3	7.6	7.9	8.1	8.4	8.7	9.0	9.3	9.6	9.9	10.2	10.5	10.8	11.1	11.3

## Applicable Controllers

The RCS4 series actuators can be operated by the controllers indicated below. Please select the type depending on your intended use.

Name	External view	Max. number of connectable axes	Input power	Control method				Maximum number of positioning points	Reference page
				Positioner	Pulse train	Program	Network * Option		
SCON-CB/CGB		1	Single phase 230VAC	●	●	—	DeviceNet CC-Link CANopen CompoNet EtherCAT EtherNet/IP	512 (768 for network spec.)	Please see P.151
SCON-LC/LCG (*)		1		—	—	●		512 (768 for network spec.)	
SSEL-CS		2	Single phase 115V/230VAC	●	—	●	Note: The type of compatible networks will vary depending on the controller. Please refer to the reference page for more information.	20000	Please see the dedicated controller catalog or manual.
XSEL-P/Q or XSEL-RA/SA (*)		6 or 8 (Depending on the type)	Single phase 230VAC Three-phase 230VAC	—	—	●		20000 or 55000 (Depending on the type)	

(\*) Coming soon

Foreword  
Slider Type  
Wide Slider Type  
Rod Type  
Radial Cylinder  
Wide Radial Cylinder  
Table Type  
Cleanroom Slider  
Cleanroom Wide Slider  
Options  
Reference Data  
Controller

# RCS4-SA4R



±10µm  
Standard



Simple  
Dust-proof



Battery-less  
Absolute



Motor Unit  
Coupled



Side-mounted  
Motor



Body Width  
40mm



230v  
AC Servo  
Motor

<b>Model Specification Items</b>	<b>RCS4</b>	<b>SA4R</b>	<b>WA</b>	<b>60</b>			<b>T2</b>			* Body width does not include the width of the side-mounted motor.
	Series	Type	Encoder Type	Motor Type	Lead	Stroke	Applicable Controllers	Cable Length	Options	
			WA: Battery-less Absolute	60: Servo motor 60W	16:16mm 10:10mm 5: 5mm 2.5:2.5mm	50:50mm ? 500:500mm (50mm increments)	T2:S:CON M:SCON S:SEL X:SEL-P/Q X:SEL-RA/SA	N : None P : 1m S : 3m M : 5m X□□ : Specified Length R□□ : Robot Cable	Refer to Options table below.	

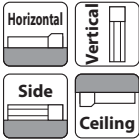

\* Depending on the model, there may be some limitations to using the vertical, side, and ceiling mount positions. Please refer to the Selection Notes on P.138 for more information.

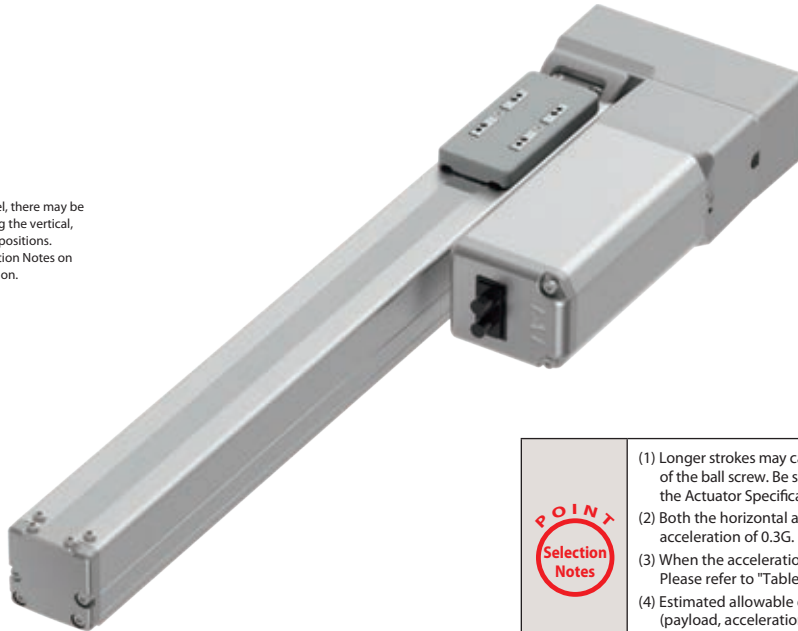

POINT Selection Notes

- (1) Longer strokes may cause the maximum speed to decrease due to resonance of the ball screw. Be sure to check the maximum speed of the desired stroke in the Actuator Specifications table, which can be found below.
- (2) Both the horizontal and vertical payloads assume operation at an acceleration of 0.3G.
- (3) When the acceleration is increased, the payload will be reduced. Please refer to "Table of Payload by Acceleration" on P.139 for more details.
- (4) Estimated allowable duty varies depending on operating conditions (payload, acceleration/deceleration, etc.). Please refer to P. 149 for more information.

## Actuator Specifications

### Lead and Payload

Model Number	Motor wattage (W)	Lead (mm)	Max. payload		Rated thrust (N)	Stroke (mm)
			Horizontal (kg)	Vertical (kg)		
RCS4-SA4R-WA-60-16-①-T2-②-③	60	16	10	2.5	53	50~500 (50mm increments)
RCS4-SA4R-WA-60-10-①-T2-②-③		10	14	4.5	85	
RCS4-SA4R-WA-60-5-①-T2-②-③		5	17	8	170	
RCS4-SA4R-WA-60-2.5-①-T2-②-③		2.5	20	12	340	

Legend: ① Stroke ② Cable Length ③ Option

### Stroke and Max Speed (Unit: mm/s)

Lead	Stroke	50~450 (50mm increments)		500 (mm)
		50~450 (50mm increments)	500 (mm)	
16		960		875
10		600		555
5		300		275
2.5		150		135

## Cable Length

Type	Cable Code
Standard	P (1m)
	S (3m)
	M (5m)
Specified length (Standard cable)	X06 (6m) ~ X10 (10m)
	X11 (11m) ~ X15 (15m)
	X16 (16m) ~ X20 (20m)
	R01 (1m) ~ R03 (3m)
Robot cable	R04 (4m) ~ R05 (5m)
	R06 (6m) ~ R10 (10m)
	R11 (11m) ~ R15 (15m)
	R16 (16m) ~ R20 (20m)

## Options

Name	Option Code	Reference Page
Brake	B	See P.131
Cable exit direction (Top)	CJT	See P.131
Cable exit direction (Bottom)	CJB	See P.131
Cable exit direction (Outside)	CJO	See P.131
Motor side-mounted to left (standard)	ML	See P.135
Motor side-mounted to right	MR	See P.135
Non-motor end specification	NM	See P.136
Back mounting plate	RP	See P.137
Slider roller specification	SR	See P.137
Slider spacer	SS	See P.137
Double slider (*1)	W	See P.137

(\*1) Some leads cannot be selected. (Please see P. 150) (\*2) EU option will be available soon.

## Actuator Specifications

Item	Description
Drive system	Ball screw ø8mm, rolled C10
Positioning repeatability	±0.01mm
Lost motion	0.1mm or less
Base	Material: Aluminum with white alumite treatment
Allowable static moment	Ma direction 13.0N·m, Mb direction 18.6N·m, Mc direction 25.3N·m
Allowable dynamic moment (*1)	Ma direction 5.0N·m, Mb direction 7.1N·m, Mc direction 9.7N·m
Ambient operating temp. & humidity	0~40°C, 85% RH or less (Non-condensing)

(\*1) Assumes a standard rated life of 5000km. The service life will vary depending on operation and installation conditions. Please contact IAI for details of the running life.

• Reference for overhang load length: Ma: 150mm or less, Mb, Mc: 150mm or less

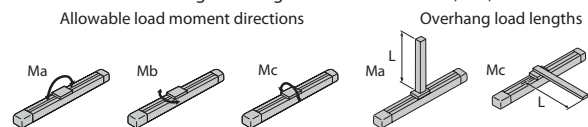

If the load moments in Ma/Mb/Mc direction are within the allowable ranges, there is no overhang load length limit.

Round cable joint connector with screw locking (*2)	EU	See P.131
---	----	-----------

## Dimensions

CAD drawings can be downloaded from our website.  
www.robocylinder.de



\*1 When the slider is returning to its home position, please be careful of interference from surrounding objects, as it will travel until it reaches the M.E.  
M.E: Mechanical end S.E: Stroke end

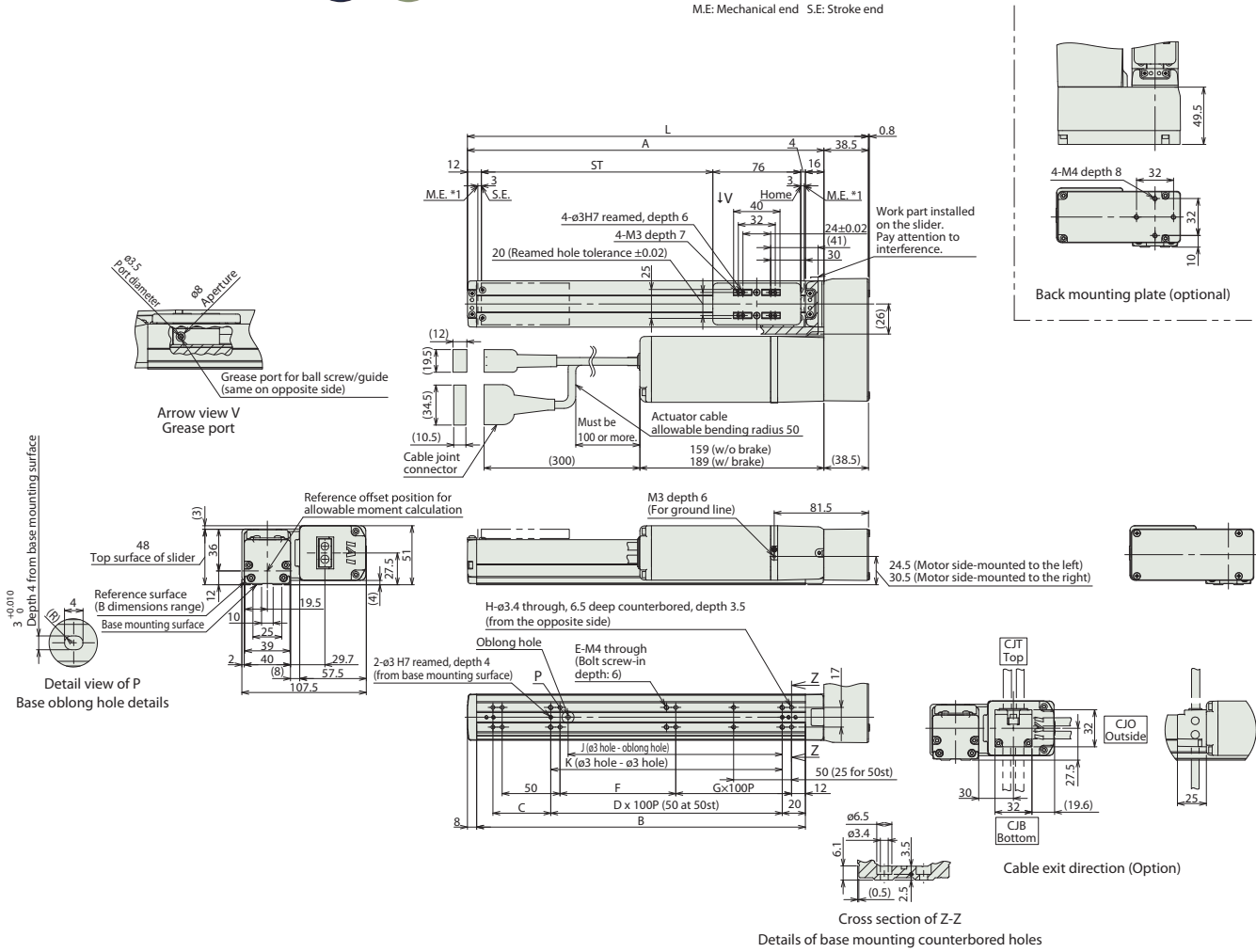

### ■ Dimensions and Mass by Stroke

Stroke	50	100	150	200	250	300	350	400	450	500	
L	196.5	246.5	296.5	346.5	396.5	446.5	496.5	546.5	596.5	646.5	
A	158	208	258	308	358	408	458	508	558	608	
B	134	184	234	284	334	384	434	484	534	584	
C	50	50	100	50	100	50	100	50	100	50	
D	-	1	1	2	2	3	3	4	4	5	
E	6	6	6	8	8	10	10	12	12	14	
F	50	100	50	100	50	100	50	100	50	100	
G	0	0	1	1	2	2	3	3	4	4	
H	8	8	10	10	12	12	14	14	16	16	
J	35	85	85	185	185	285	285	385	385	485	
K	50	100	100	200	200	300	300	400	400	500	
Mass (kg)	W/o brake	1.5	1.6	1.7	1.7	1.8	1.9	2.0	2.1	2.2	2.3
	W/ brake	1.7	1.8	1.9	1.9	2.0	2.1	2.2	2.3	2.4	2.5

### Applicable Controllers

The RCS4 series actuators can be operated by the controllers indicated below. Please select the type depending on your intended use.

Name	External view	Max. number of connectable axes	Input power	Control method				Maximum number of positioning points	Reference page
				Positioner	Pulse train	Program	Network * Option		
SCON-CB/CGB		1	Single phase 115V/230VAC	●	●	-	DeviceNet CC-Link PROFINET CompoNet EtherCAT EtherNet/IP	512 (768 for network spec.)	Please see P.151
SCON-LC/LCG (*)		1		-	-	●		512 (768 for network spec.)	
SCON-CAL/CGAL		1		●	-	-		512 (768 for network spec.)	
MSCON-C		6		This model is network-compatible only.				256	
SSEL-CS		2		●	-	●	20000		
XSEL-P/Q or XSEL-RA/SA (*)		6 or 8 (Depending on the type)	Single phase 230VAC Three-phase 230VAC	-	-	●	20000 or 55000 (Depending on the type)	Please see the dedicated controller catalog or manual.	
Note: The type of compatible networks will vary depending on the controller. Please refer to the reference page for more information.									

(\*) Coming soon

Foreword  
Slider Type  
Wide Slider Type  
Rod Type  
Radial Cylinder  
Wide Radial Cylinder  
Table Type  
Cleanroom Slider  
Cleanroom Wide Slider  
Options  
Reference Data  
Controller

# RCS4-SA6R



±10µm  
Standard



Simple  
Dust-proof



Battery-less  
Absolute



Motor  
Unit  
Coupled



Side-mounted  
Motor



Body Width  
60mm\*



230v  
AC Servo  
Motor

<b>Model Specification Items</b>	<b>RCS4</b> — <b>SA6R</b> — <b>WA</b> — <b>100</b> — <span style="border: 1px solid black; display: inline-block; width: 15px; height: 15px;"></span> — <span style="border: 1px solid black; display: inline-block; width: 15px; height: 15px;"></span> — <b>T2</b> — <span style="border: 1px solid black; display: inline-block; width: 15px; height: 15px;"></span> — <span style="border: 1px solid black; display: inline-block; width: 15px; height: 15px;"></span>	* Body width does not include the width of the side-mounted motor.	
	Series — Type — Encoder Type — Motor Type — Lead — Stroke — Applicable Controllers — Cable Length — Options	WA: Battery-less Absolute      100: Servo motor 100W	30:30mm 20:20mm 12:12mm 6: 6mm 3: 3mm
	T2:SCON MSCON SSEL XSEL-P/Q XSEL-RA/SA	N : None P : 1m S : 3m M : 5m X□□ : Specified Length R□□ : Robot Cable	Refer to Options table below.

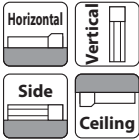

\* Depending on the model, there may be some limitations to using the vertical, side, and ceiling mount positions. Please refer to the Selection Notes on P.138 for more information.



- (1) Longer strokes may cause the maximum speed to decrease due to resonance of the ball screw. Be sure to check the maximum speed of the desired stroke in the Actuator Specifications table, which can be found below.
- (2) Both the horizontal and vertical payloads assume operation at an acceleration of 0.3G.
- (3) When the acceleration is increased, the payload will be reduced. Please refer to "Table of Payload by Acceleration" on P.139 for more details.
- (4) Estimated allowable duty varies depending on operating conditions (payload, acceleration/deceleration, etc.). Please refer to P. 149 for more information.

## Actuator Specifications

### Lead and Payload

Model Number	Motor wattage (W)	Lead (mm)	Max. payload (kg)	Rated thrust (N)	Stroke (mm)
RCS4-SA6R-WA-100-30-①-T2-②-③	100	30	11	3	50-800 (50mm increments)
RCS4-SA6R-WA-100-20-①-T2-②-③		20	18	5	
RCS4-SA6R-WA-100-12-①-T2-②-③		12	30	9	
RCS4-SA6R-WA-100-6-①-T2-②-③		6	45	15	
RCS4-SA6R-WA-100-3-①-T2-②-③		3	45	15	

Legend: ① Stroke ② Cable Length ③ Option

### Stroke and Max Speed

(Unit: mm/s)

Stroke / Lead	50-500 (50mm increments)	550 (mm)	600 (mm)	650 (mm)	700 (mm)	750 (mm)	800 (mm)
	30	1600	1450	1260	1100	970	860
20	1200	1130	970	840	735	650	
12	720	620	535	460	405	355	
6	360	305	265	230	200	175	
3	180	150	130	115	100	85	

## Cable Length

Type	Cable Code
Standard	<b>P</b> (1m)
	<b>S</b> (3m)
	<b>M</b> (5m)
Specified length (Standard cable)	<b>X06</b> (6m) ~ <b>X10</b> (10m)
	<b>X11</b> (11m) ~ <b>X15</b> (15m)
	<b>X16</b> (16m) ~ <b>X20</b> (20m)
	<b>R01</b> (1m) ~ <b>R03</b> (3m)
Robot cable	<b>R04</b> (4m) ~ <b>R05</b> (5m)
	<b>R06</b> (6m) ~ <b>R10</b> (10m)
	<b>R11</b> (11m) ~ <b>R15</b> (15m)
	<b>R16</b> (16m) ~ <b>R20</b> (20m)

## Options

Name	Option Code	Reference Page
Brake	<b>B</b>	See P.131
Cable exit direction (Top)	<b>CJT</b>	See P.131
Cable exit direction (Bottom)	<b>CJB</b>	See P.131
Cable exit direction (Outside)	<b>CJO</b>	See P.131
Motor side-mounted to left (standard)	<b>ML</b>	See P.135
Motor side-mounted to right	<b>MR</b>	See P.135
Non-motor end specification	<b>NM</b>	See P.136
Slider roller specification	<b>SR</b>	See P.137
Double slider (*1)	<b>W</b>	See P.137

(\*1) Some leads cannot be selected. (Please see P. 150) (\*2) EU option will be available soon.

## Actuator Specifications

Item	Description
Drive system	Ball screw ø10mm, rolled C10
Positioning repeatability	±0.01mm
Lost motion	0.1mm or less
Base	Material: Aluminum with white alumite treatment
Allowable static moment	Ma direction: 48.5N·m, Mb direction: 69.3N·m, Mc direction: 103N·m
Allowable dynamic moment (*1)	Ma direction: 11.6N·m, Mb direction: 16.6N·m, Mc direction: 24.6N·m
Ambient operating temp. & humidity	0~40°C, 85% RH or less (Non-condensing)

(\*1) Assumes a standard rated life of 5000km. The service life will vary depending on operation and installation conditions. Please contact IAI for details of the running life.

- Reference for overhang load length: Ma: 220mm or less, Mb, Mc: 220mm or less

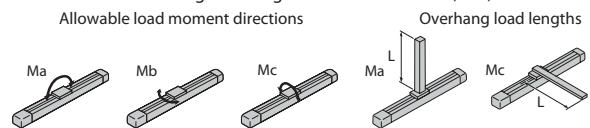

If the load moments in Ma/Mb/Mc direction are within the allowable ranges, there is no overhang load length limit.

Round cable joint connector with screw locking (*2)	<b>EU</b>	See P.131
---	-----------	-----------

## Dimensions

CAD drawings can be downloaded from our website.  
www.robocylinder.de



\*1 When the slider is returning to its home position, please be careful of interference from surrounding objects, as it will travel until it reaches the M.E.  
M.E: Mechanical end S.E: Stroke end

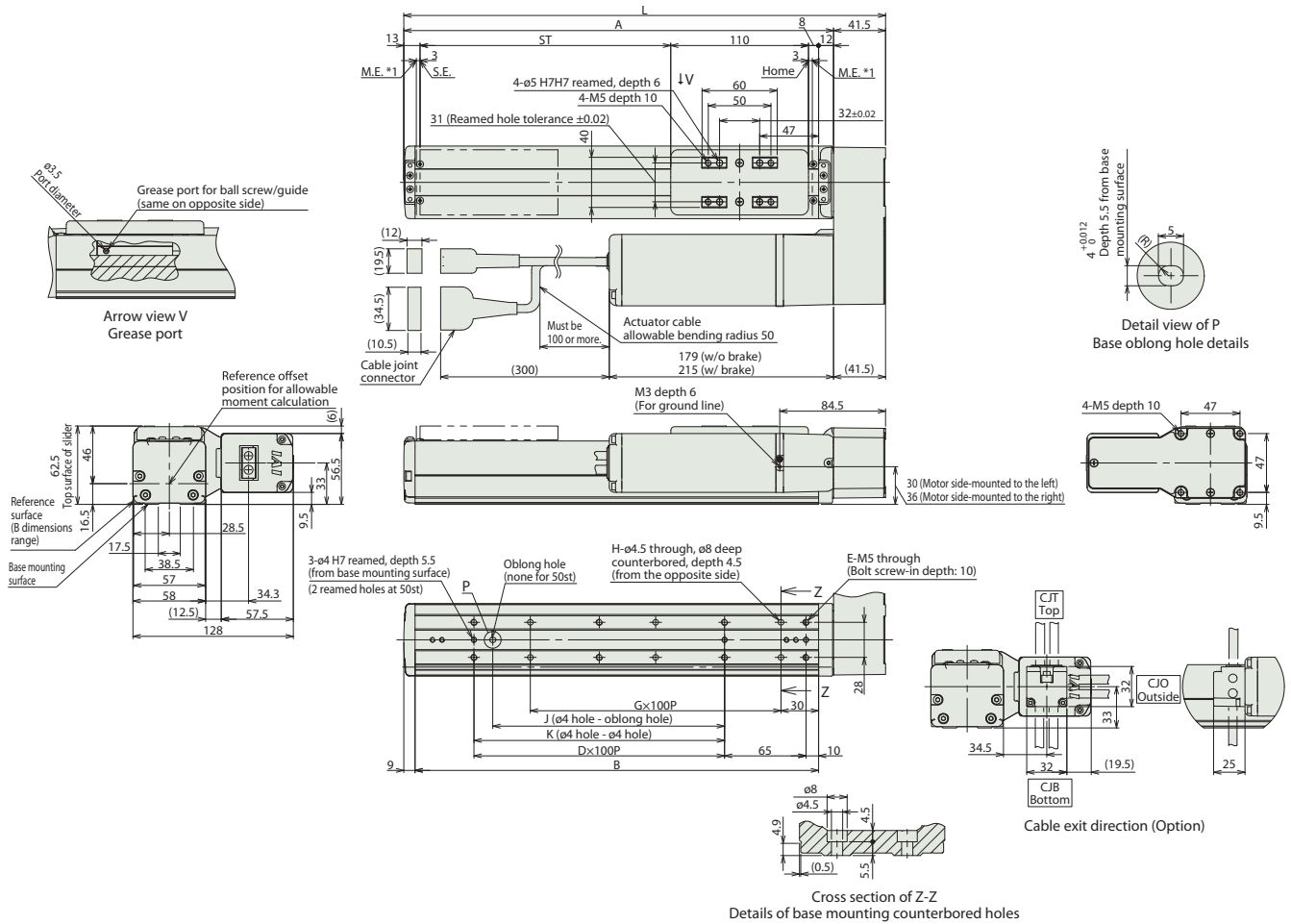

## Dimensions and Mass by Stroke

Stroke	50	100	150	200	250	300	350	400	450	500	550	600	650	700	750	800
L	234.5	284.5	334.5	384.5	434.5	484.5	534.5	584.5	634.5	684.5	734.5	784.5	834.5	884.5	934.5	984.5
A	193	243	293	343	393	443	493	543	593	643	693	743	793	843	893	943
B	172	222	272	322	372	422	472	522	572	622	672	722	772	822	872	922
D	0	1	1	2	2	3	3	4	4	5	5	6	6	7	7	8
E	4	6	6	8	8	10	10	12	12	14	14	16	16	18	18	20
G	1	1	2	2	3	3	4	4	5	5	6	6	7	7	8	8
H	4	4	6	6	8	8	10	10	12	12	14	14	16	16	18	18
J	0	85	85	185	185	285	285	385	385	485	485	585	585	685	685	785
K	0	100	100	200	200	300	300	400	400	500	500	600	600	700	700	800
Mass (kg)																
W/o brake	2.4	2.5	2.7	2.9	3.1	3.2	3.4	3.6	3.8	4.0	4.1	4.3	4.5	4.7	4.9	5.0
W/brake	2.7	2.8	3.0	3.2	3.4	3.5	3.7	3.9	4.1	4.3	4.4	4.6	4.8	5.0	5.2	5.3

## Applicable Controllers

The RCS4 series actuators can be operated by the controllers indicated below. Please select the type depending on your intended use.

Name	External view	Max. number of connectable axes	Input power	Control method				Maximum number of positioning points	Reference page
				Positioner	Pulse train	Program	Network * Option		
SCON-CB/CGB		1	Single phase 115V/230VAC	●	●	—	DeviceNet CC-Link CC-Link IE CompoNet EtherCAT EtherNet/IP	512 (768 for network spec.)	Please see the dedicated controller catalog or manual.
SCON-LC/LCG (*)		1		—	—	●		512 (768 for network spec.)	
SCON-CAL/CGAL		1		●	—	—		512 (768 for network spec.)	
MSCON-C		6		This model is network-compatible only.				256	
SSEL-CS		2		●	—	●	20000		
XSEL-P/Q or XSEL-RA/SA (*)		6 or 8 (Depending on the type)		Single phase 230VAC Three-phase 230VAC	—	—	●	20000 or 55000 (Depending on the type)	

Note: The type of compatible networks will vary depending on the controller. Please refer to the reference page for more information.

(\*) Coming soon

Foreword  
Slider Type  
Wide Slider Type  
Rod Type  
Radial Cylinder  
Wide Radial Cylinder  
Table Type  
Cleanroom Slider  
Cleanroom Wide Slider  
Options  
Reference Data  
Controller

# RCS4-SA7R



±10µm  
Standard



Simple  
Dust-proof



Battery-less  
Absolute



Motor Unit  
Coupled



Side-mounted  
Motor



Body Width  
70\*  
mm



230v  
AC Servo  
Motor

<b>Model Specification Items</b>	<b>RCS4</b>	<b>SA7R</b>	<b>WA</b>	<b>200</b>								* Body width does not include the width of the side-mounted motor.
	Series	Type	Encoder Type	Motor Type	Lead	Stroke	Applicable Controllers	Cable Length	Options			
			WA: Battery-less Absolute	200: Servo motor 200W	36:36mm 24:24mm 16:16mm 8: 8mm 4: 4mm	50:50mm + 800:800mm (50mm increments)	T2:SCON MSCON SSEL XSEL-P/Q XSEL-RA/SA	N : None P : 1m S : 3m M : 5m X□□ : Specified Length R□□ : Robot Cable	Refer to Options table below.			

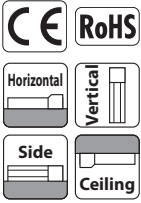

\* Depending on the model, there may be some limitations to using the vertical, side, and ceiling mount positions. Please refer to the Selection Notes on P.138 for more information.

**POINT**  
Selection  
Notes

- (1) Longer strokes may cause the maximum speed to decrease due to resonance of the ball screw. Be sure to check the maximum speed of the desired stroke in the Actuator Specifications table, which can be found below.
- (2) Both the horizontal and vertical payloads assume operation at an acceleration of 0.3G.
- (3) When the acceleration is increased, the payload will be reduced. Please refer to "Table of Payload by Acceleration" on P.139 for more details.
- (4) Estimated allowable duty varies depending on operating conditions (payload, acceleration/deceleration, etc.). Please refer to P. 149 for more information.

## Actuator Specifications

### Lead and Payload

Model Number	Motor wattage (W)	Lead (mm)	Max. payload Horizontal (kg)	Max. payload Vertical (kg)	Rated thrust (N)	Stroke (mm)
RCS4-SA7R-WA-200-36-①-T2-②-③	200	36	7	4	95	50~800 (50mm increments)
RCS4-SA7R-WA-200-24-①-T2-②-③		24	30	6	142	
RCS4-SA7R-WA-200-16-①-T2-②-③		16	38	12	214	
RCS4-SA7R-WA-200-8-①-T2-②-③		8	45	18	427	
RCS4-SA7R-WA-200-4-①-T2-②-③		4	50	25	855	

Legend: ① Stroke ② Cable Length ③ Option

### Stroke and Max Speed

(Unit: mm/s)

Stroke Lead	Stroke (mm)						
	50~500 (50mm increments)	550	600	650	700	750	800
36	1800			1620	1420	1260	1120
24	1500	1440	1240	1095	965	850	760
16	1000	965	830	720	635	560	500
8	500	475	410	355	315	275	245
4	240	235	205	175	155	135	120

## Cable Length

Type	Cable Code
Standard	<b>P</b> (1m)
	<b>S</b> (3m)
	<b>M</b> (5m)
Specified length (Standard cable)	<b>X06</b> (6m) ~ <b>X10</b> (10m)
	<b>X11</b> (11m) ~ <b>X15</b> (15m)
	<b>X16</b> (16m) ~ <b>X20</b> (20m)
	<b>R01</b> (1m) ~ <b>R03</b> (3m)
Robot cable	<b>R04</b> (4m) ~ <b>R05</b> (5m)
	<b>R06</b> (6m) ~ <b>R10</b> (10m)
	<b>R11</b> (11m) ~ <b>R15</b> (15m)
	<b>R16</b> (16m) ~ <b>R20</b> (20m)

## Options

Name	Option Code	Reference Page
Brake	<b>B</b>	See P.131
Cable exit direction (Top)	<b>CJT</b>	See P.131
Cable exit direction (Bottom)	<b>CJB</b>	See P.131
Cable exit direction (Outside)	<b>CJO</b>	See P.131
Motor side-mounted to left (standard)	<b>ML</b>	See P.135
Motor side-mounted to right	<b>MR</b>	See P.135
Non-motor end specification	<b>NM</b>	See P.136
Slider roller specification	<b>SR</b>	See P.137
Slider spacer	<b>SS</b>	See P.137
Double slider (*1)	<b>W</b>	See P.137

(\*1) Some leads cannot be selected. (Please see P. 150) (\*2) EU option will be available soon.

## Actuator Specifications

Item	Description
Drive system	Ball screw ø12mm, rolled C10
Positioning repeatability	±0.01mm
Lost motion	0.1mm or less
Base	Material: Aluminum with white alumite treatment
Allowable static moment	Ma direction 115N·m, Mb direction 115N·m, Mc direction 229N·m
Allowable dynamic moment (*1)	Ma direction 44.7N·m, Mb direction 44.7N·m, Mc direction 89.1N·m
Ambient operating temp. & humidity	0~40°C, 85% RH or less (Non-condensing)

(\*1) Assumes a standard rated life of 5000km. The service life will vary depending on operation and installation conditions. Please contact IAI for details of the running life.

- Reference for overhang load length: Ma: 300mm or less, Mb, Mc: 300mm or less

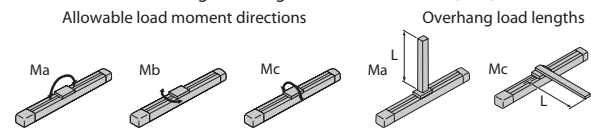

If the load moments in Ma/Mb/Mc direction are within the allowable ranges, there is no overhang load length limit.

Round cable joint connector with screw locking (*2)	<b>EU</b>	See P.131
---	-----------	-----------



## Dimensions

CAD drawings can be downloaded from our website.  
www.robocylinder.de



\*1 When the slider is returning to its home position, please be careful of interference from surrounding objects, as it will travel until it reaches the M.E.  
M.E: Mechanical end S.E: Stroke end

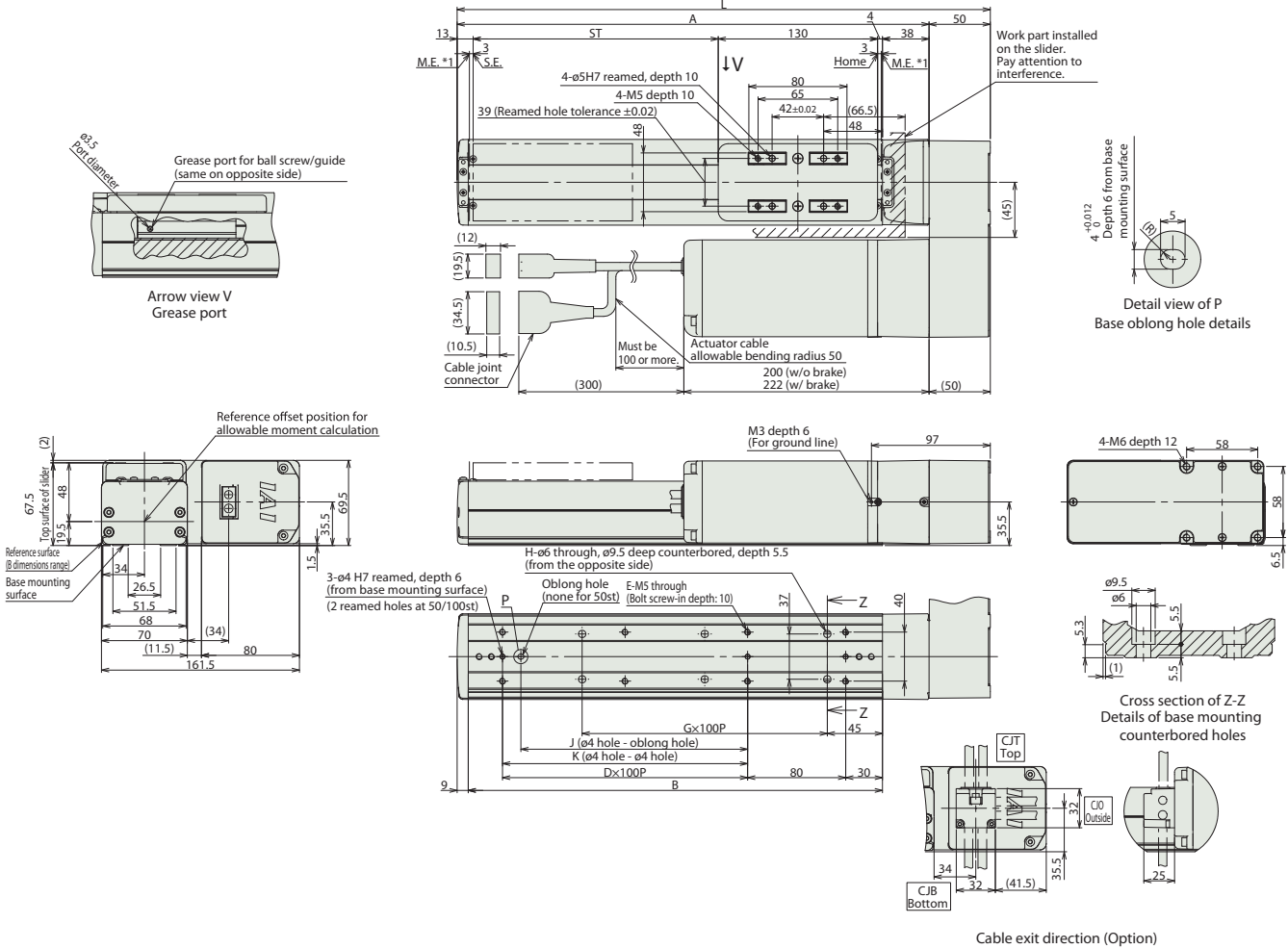

## Dimensions and Mass by Stroke

Stroke	50	100	150	200	250	300	350	400	450	500	550	600	650	700	750	800
L	285	335	385	435	485	535	585	635	685	735	785	835	885	935	985	1035
A	235	285	335	385	435	485	535	585	635	685	735	785	835	885	935	985
B	188	238	288	338	388	438	488	538	588	638	688	738	788	838	888	938
D	0	1	1	2	2	3	3	4	4	5	5	6	6	7	7	8
E	4	6	6	8	8	10	10	12	12	14	14	16	16	18	18	20
G	1	1	2	2	3	3	4	4	5	5	6	6	7	7	8	8
H	4	4	6	6	8	8	10	10	12	12	14	14	16	16	18	18
J	0	85	85	185	185	285	285	385	385	485	485	585	585	685	685	785
K	0	0	100	200	200	300	300	400	400	500	500	600	600	700	700	800
Mass (kg)	W/o brake	4.3	4.6	4.8	5.0	5.3	5.5	5.8	6.0	6.2	6.5	6.7	6.9	7.2	7.4	7.9
	W/brake	4.8	5.1	5.3	5.5	5.8	6.0	6.3	6.5	6.7	7.0	7.2	7.4	7.7	7.9	8.4

## Applicable Controllers

The RCS4 series actuators can be operated by the controllers indicated below. Please select the type depending on your intended use.

Name	External view	Max. number of connectable axes	Input power	Control method				Maximum number of positioning points	Reference page	
				Positioner	Pulse train	Program	Network * Option			
SCON-CB/CGB		1	Single phase 115V/230VAC	●	●	—	DeviceNet CC-Link CANopen CompoNet EtherCAT EtherNet/IP Note: The type of compatible networks will vary depending on the controller. Please refer to the reference page for more information.	512 (768 for network spec.)	Please see the dedicated controller catalog or manual.	
SCON-LC/LCG (*)		1		—	—	●		512 (768 for network spec.)		
SCON-CAL/CGAL		1		●	—	—		512 (768 for network spec.)		
MSCON-C		6		This model is network-compatible only.				256		
SSEL-CS		2		●	—	●		20000		
XSEL-P/Q or XSEL-RA/SA (*)		6 or 8 (Depending on the type)	Single phase 230VAC Three-phase 230VAC	—	—	●	20000 or 55000 (Depending on the type)			

(\*) Coming soon

Foreword  
Slider Type  
Wide Slider Type  
Rod Type  
Radial Cylinder  
Wide Radial Cylinder  
Table Type  
Cleanroom Slider  
Cleanroom Wide Slider  
Options  
Reference Data  
Controller

# RCS4-SA8R

±10μm  
Standard

Simple  
Dust-proof

Battery-less  
Absolute

Motor  
Unit  
Coupled

Side-mounted  
Motor

Body Width  
**90\***  
mm

**230v**  
AC Servo  
Motor

<b>Model Specification Items</b>	<b>RCS4</b> — <b>SA8R</b> — <b>WA</b> — <b>400</b> — <span style="border: 1px solid black; display: inline-block; width: 15px; height: 15px;"></span> — <span style="border: 1px solid black; display: inline-block; width: 15px; height: 15px;"></span> — <b>T2</b> — <span style="border: 1px solid black; display: inline-block; width: 15px; height: 15px;"></span> — <span style="border: 1px solid black; display: inline-block; width: 15px; height: 15px;"></span>	* Body width does not include the width of the side-mounted motor.	
	Series — Type — Encoder Type — Motor Type — Lead — Stroke — Applicable Controllers — Cable Length — Options		
	WA: Battery-less Absolute      400: Servo motor 400W	48:48mm 30:30mm 20:20mm 10:10mm 5: 5mm	50:50mm 1100:1100mm (50mm increments)
		T2:SCON SSEL XSEL-P/Q XSEL-RA/SA	N : None P : 1m S : 3m M : 5m X□□ : Specified Length R□□ : Robot Cable

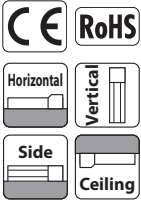

\* Depending on the model, there may be some limitations to using the vertical, side, and ceiling mount positions. Please refer to the Selection Notes on P.138 for more information.

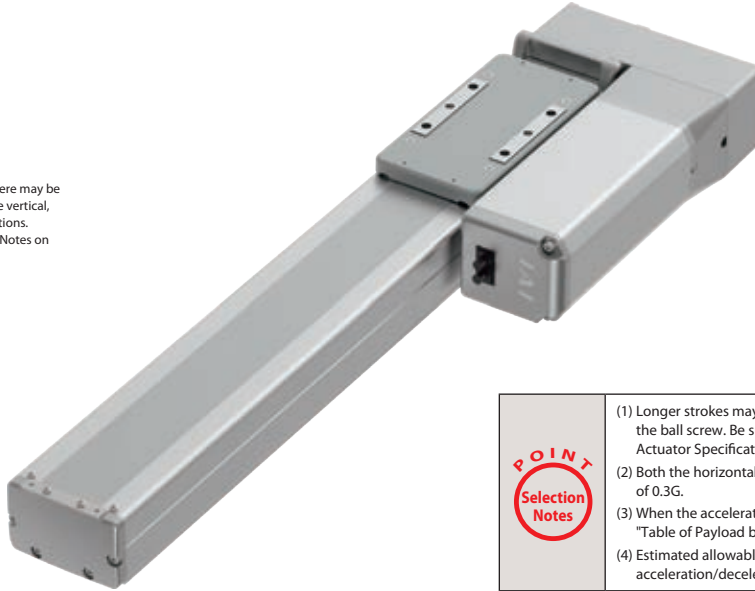

- (1) Longer strokes may cause the maximum speed to decrease due to resonance of the ball screw. Be sure to check the maximum speed of the desired stroke in the Actuator Specifications table, which can be found below.
- (2) Both the horizontal and vertical payloads assume operation at an acceleration of 0.3G.
- (3) When the acceleration is increased, the payload will be reduced. Please refer to "Table of Payload by Acceleration" on P.139 for more details.
- (4) Estimated allowable duty varies depending on operating conditions (payload, acceleration/deceleration, etc.). Please refer to P. 149 for more information.

## Actuator Specifications

### Lead and Payload

Model Number	Motor wattage (W)	Lead (mm)		Rated thrust (N)	Stroke (mm)
		Horizontal (kg)	Vertical (kg)		
RCS4-SA8R-WA-400-48-①-T2-②-③	400	48	8	141	50~1100 (50mm increments)
RCS4-SA8R-WA-400-30-①-T2-②-③		30	30	226	
RCS4-SA8R-WA-400-20-①-T2-②-③		20	60	339	
RCS4-SA8R-WA-400-10-①-T2-②-③		10	80	678	
RCS4-SA8R-WA-400-5-①-T2-②-③		5	90	1357	

Legend: ① Stroke ② Cable Length ③ Option

### Stroke and Max Speed

(Unit: mm/s)

Stroke / Lead	Stroke (mm)										
	50-600 (50mm increments)	650 (mm)	700 (mm)	750 (mm)	800 (mm)	850 (mm)	900 (mm)	950 (mm)	1000 (mm)	1050 (mm)	1100 (mm)
48	2100			1950	1760	1590	1450	1320	1210	1110	
30	1800	1640	1440	1280	1155	1040	940	855	780	715	660
20	1200	1090	960	860	770	695	630	570	520	480	440
10	600	540	480	430	385	345	310	285	260	235	220
5	300	270	240	215	190	175	155	140	130	120	110

## Cable Length

Type	Cable Code
Standard	<b>P</b> (1m)
	<b>S</b> (3m)
	<b>M</b> (5m)
Specified length (Standard cable)	<b>X06</b> (6m) ~ <b>X10</b> (10m)
	<b>X11</b> (11m) ~ <b>X15</b> (15m)
	<b>X16</b> (16m) ~ <b>X20</b> (20m)
	<b>R01</b> (1m) ~ <b>R03</b> (3m)
Robot cable	<b>R04</b> (4m) ~ <b>R05</b> (5m)
	<b>R06</b> (6m) ~ <b>R10</b> (10m)
	<b>R11</b> (11m) ~ <b>R15</b> (15m)
	<b>R16</b> (16m) ~ <b>R20</b> (20m)

## Options

Name	Option Code	Reference Page
Brake	<b>B</b>	See P.131
Cable exit direction (Top)	<b>CJT</b>	See P.131
Cable exit direction (Bottom)	<b>CJB</b>	See P.131
Cable exit direction (Outside)	<b>CJO</b>	See P.131
Motor side-mounted to left (standard)	<b>ML</b>	See P.135
Motor side-mounted to right	<b>MR</b>	See P.135
Non-motor end specification	<b>NM</b>	See P.136
Slider roller specification	<b>SR</b>	See P.137
Slider spacer	<b>SS</b>	See P.137
Double slider (*1)	<b>W</b>	See P.137

(\*1) Some leads cannot be selected. (Please see P. 150) (\*2) EU option will be available soon.

## Actuator Specifications

Item	Description
Drive system	Ball screw ø16mm, rolled C10
Positioning repeatability	±0.01mm
Lost motion	0.1mm or less
Base	Material: Aluminum with white alumite treatment
Allowable static moment	Ma direction 219N·m, Mb direction 219N·m, Mc direction 414N·m
Allowable dynamic moment (*1)	Ma direction 77.0N·m, Mb direction 77.0N·m, Mc direction 146N·m
Ambient operating temp. & humidity	0~40°C, 85% RH or less (Non-condensing)

(\*1) Assumes a standard rated life of 5000km. The service life will vary depending on operation and installation conditions. Please contact IAI for details of the running life.

- Reference for overhang load length: Ma: 400mm or less, Mb, Mc: 400mm or less

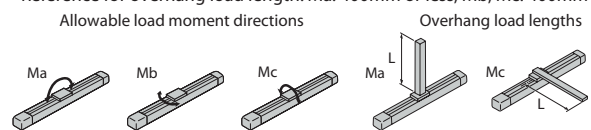

If the load moments in Ma/Mb/Mc direction are within the allowable ranges, there is no overhang load length limit.

Round cable joint connector with screw locking (*2)	<b>EU</b>	See P.131
---	-----------	-----------

## Dimensions

CAD drawings can be downloaded from our website.  
www.robocylinder.de



\*1 When the slider is returning to its home position, please be careful of interference from surrounding objects, as it will travel until it reaches the M.E.  
M.E: Mechanical end S.E: Stroke end

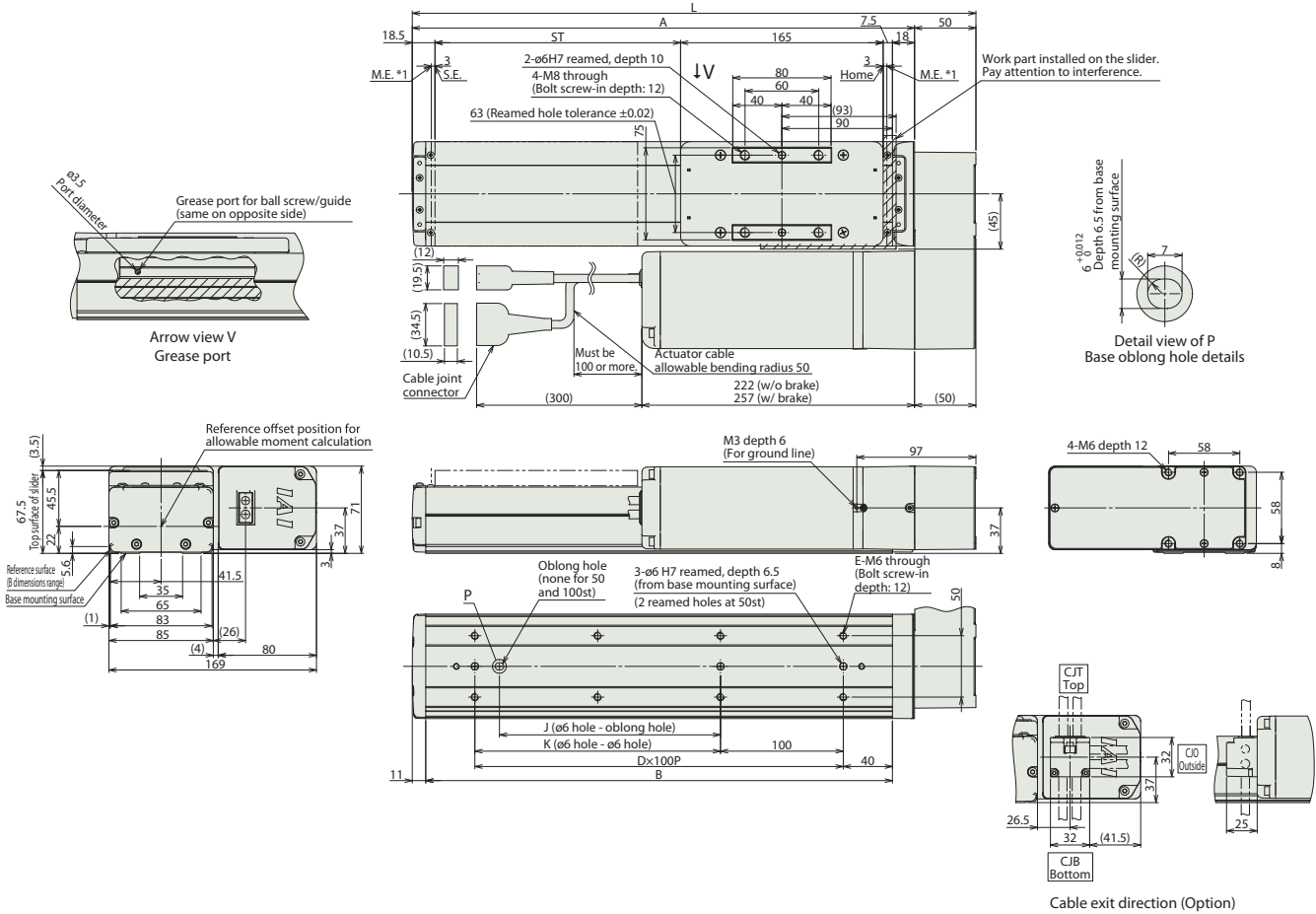

## Dimensions and Mass by Stroke

Stroke	50	100	150	200	250	300	350	400	450	500	550	600	650	700	750	800	850	900	950	1000	1050	1100	
L	309	359	409	459	509	559	609	659	709	759	809	859	909	959	1009	1059	1109	1159	1209	1259	1309	1359	
A	259	309	359	409	459	509	559	609	659	709	759	809	859	909	959	1009	1059	1109	1159	1209	1259	1309	
B	230	280	330	380	430	480	530	580	630	680	730	780	830	880	930	980	1030	1080	1130	1180	1230	1280	
D	1	2	2	3	3	4	4	5	5	6	6	7	7	8	8	9	9	10	10	11	11	12	
E	4	6	6	8	8	10	10	12	12	14	14	16	16	18	18	20	20	22	22	24	24	26	
J	0	0	80	180	180	280	280	380	380	480	480	580	580	680	680	780	780	880	880	980	980	1080	
K	0	100	100	200	200	300	300	400	400	500	500	600	600	700	700	800	800	900	900	1000	1000	1100	
Mass (kg)	W/o brake	5.6	5.9	6.2	6.4	6.7	7.0	7.3	7.6	7.9	8.2	8.5	8.8	9.1	9.4	9.6	9.9	10.2	10.5	10.8	11.1	11.4	11.7
	W/ brake	6.1	6.4	6.7	6.9	7.2	7.5	7.8	8.1	8.4	8.7	9.0	9.3	9.6	9.9	10.1	10.4	10.7	11.0	11.3	11.6	11.9	12.2

## Applicable Controllers

The RCS4 series actuators can be operated by the controllers indicated below. Please select the type depending on your intended use.

Name	External view	Max. number of connectable axes	Input power	Control method				Maximum number of positioning points	Reference page
				Positioner	Pulse train	Program	Network * Option		
SCON-CB/CGB		1	Single phase 230VAC	●	●	—	DeviceNet CC-Link CompoNet EtherCAT EtherNet/IP	512 (768 for network spec.)	Please see P.151
SCON-LC/LCG (*)		1		—	—	●			
SSEL-CS		2	Single phase 115V/230VAC	●	—	●	Note: The type of compatible networks will vary depending on the controller. Please refer to the reference page for more information.	20000	Please see the dedicated controller catalog or manual.
XSEL-P/Q or XSEL-RA/SA (*)		6 or 8 (Depending on the type)	Single phase 230VAC Three-phase 230VAC	—	—	●		20000 or 55000 (Depending on the type)	

(\*) Coming soon

Foreword  
Slider Type  
Wide Slider Type  
Rod Type  
Radial Cylinder  
Wide Radial Cylinder  
Table Type  
Cleanroom Slider  
Cleanroom Wide Slider  
Options  
Reference Data  
Controller

# RCS4-WSA10C

±10μm  
Standard

±5μm  
Optional

Simple  
Dust-proof

Battery-  
less  
Absolute

Motor  
Unit  
Coupled

Straight  
Motor

Body Width  
**100  
mm**

**230v**  
AC Servo  
Motor

<b>Model Specification Items</b>	<b>RCS4</b>	<b>WSA10C</b>	<b>WA</b>	<b>60</b>			<b>T2</b>		
	Series	Type	Encoder Type	Motor Type	Lead	Stroke	Applicable Controllers	Cable Length	Options
			WA: Battery-less Absolute	60: Servo motor 60W	16: 16mm 10: 10mm 5: 5mm 2.5: 2.5mm	50: 50mm + 500: 500mm (50mm increments)	T2: SCON MSCON SSEL XSEL-P/Q XSEL-RA/SA	N: None P: 1m S: 3m M: 5m X□□: Specified Length R□□: Robot Cable	Refer to Options table below. * Be sure to select an option for the cable exit direction.

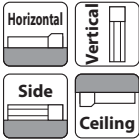

\* Depending on the model, there may be some limitations to using the vertical, side, and ceiling mount positions. Please refer to the Selection Notes on P.138 for more information.

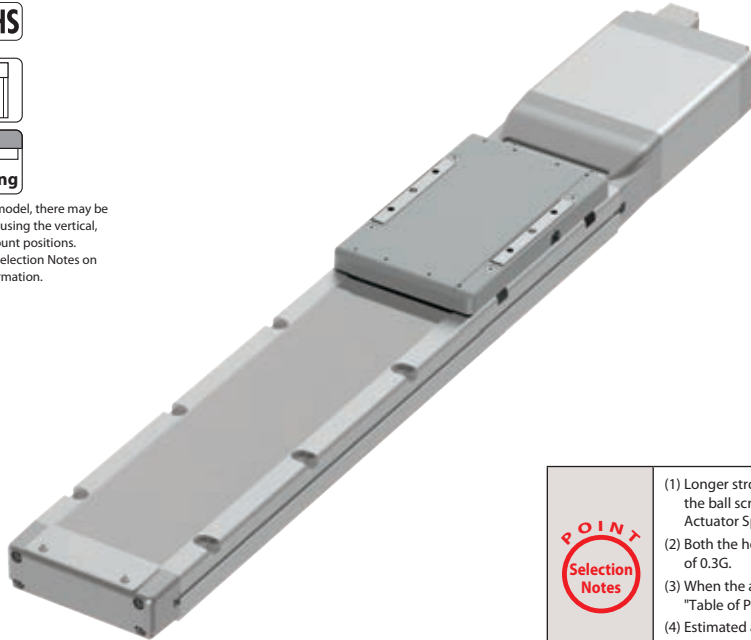

POINT Selection Notes

- (1) Longer strokes may cause the maximum speed to decrease due to resonance of the ball screw. Be sure to check the maximum speed of the desired stroke in the Actuator Specifications table, which can be found below.
- (2) Both the horizontal and vertical payloads assume operation at an acceleration of 0.3G.
- (3) When the acceleration is increased, the payload will be reduced. Please refer to "Table of Payload by Acceleration" on P.139 for more details.
- (4) Estimated allowable duty varies depending on operating conditions (payload, acceleration/deceleration, etc.). Please refer to P. 149 for more information.

## Actuator Specifications

### Lead and Payload

Model Number	Motor wattage (W)	Lead (mm)	Max. payload		Rated thrust (N)	Stroke (mm)
			Horizontal (kg)	Vertical (kg)		
RCS4-WSA10C-WA-60-16-①-T2-②-③	60	16	7	-	53	50~500 (50mm increments)
RCS4-WSA10C-WA-60-10-①-T2-②-③		10	16	3	85	
RCS4-WSA10C-WA-60-5-①-T2-②-③		5	27	5	170	
RCS4-WSA10C-WA-60-2.5-①-T2-②-③		2.5	40	10	340	

Legend: ① Stroke ② Cable Length ③ Option

### Stroke and Max Speed

Lead	Stroke (mm)	Max Speed (Unit: mm/s)			
		50~350 (50mm increments)	400 (mm)	450 (mm)	500 (mm)
16	16	960	930	775	660
10	10	600	590	490	415
5	5	300	290	245	205
2.5	2.5	150	145	120	100

## Cable Length

Type	Cable Code
Standard	P (1m)
	S (3m)
	M (5m)
Specified length (Standard cable)	X06 (6m) ~ X10 (10m)
	X11 (11m) ~ X15 (15m)
	X16 (16m) ~ X20 (20m)
	R01 (1m) ~ R03 (3m)
Robot cable	R04 (4m) ~ R05 (5m)
	R06 (6m) ~ R10 (10m)
	R11 (11m) ~ R15 (15m)
	R16 (16m) ~ R20 (20m)

## Actuator Specifications

Item	Description
Drive system	Ball screw ø8mm, rolled C10
Positioning repeatability (*1)	±0.01mm [±0.005mm]
Lost motion	0.1mm or less
Base	Material: Aluminum with white alumite treatment
Allowable static moment	Ma direction 271N·m, Mb direction 271N·m, Mc direction 553N·m
Allowable dynamic moment (*2)	Ma direction 65.4N·m, Mb direction 65.4N·m, Mc direction 134N·m
Ambient operating temp. & humidity	0~40°C, 85% RH or less (Non-condensing)

(\*1) Values in [ ] are for high-precision specification.

(\*2) Assumes a standard rated life of 5000km. The service life will vary depending on operation and installation conditions. Please contact IAI for details of the running life.

• Reference for overhang load length: Ma: 500mm or less, Mb, Mc: 500mm or less  
Allowable load moment directions Overhang load lengths

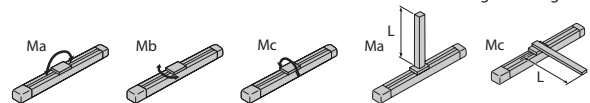

If the load moments in Ma/Mb/Mc direction are within the allowable ranges, there is no overhang load length limit.

Round cable joint connector with screw locking (*1)	<b>EU</b>	See P.131
---	-----------	-----------

## Options

Name	Option Code	Reference Page
Brake	<b>B</b>	See P.131
Cable exit direction (Top)	<b>CJT</b>	See P.131
Cable exit direction (Right)	<b>CJR</b>	See P.131
Cable exit direction (Left)	<b>CJL</b>	See P.131
Cable exit direction (Bottom)	<b>CJB</b>	See P.131
High-precision specification	<b>HPR</b>	See P.134
Non-motor end specification	<b>NM</b>	See P.136
Slider roller specification	<b>SR</b>	See P.137

(\*1) EU option will be available soon.

## Dimensions

CAD drawings can be downloaded from our website.  
www.robocylinder.de



\*1 When the slider is returning to its home position, please be careful of interference from surrounding objects, as it will travel until it reaches the M.E.  
M.E: Mechanical end S.E: Stroke end

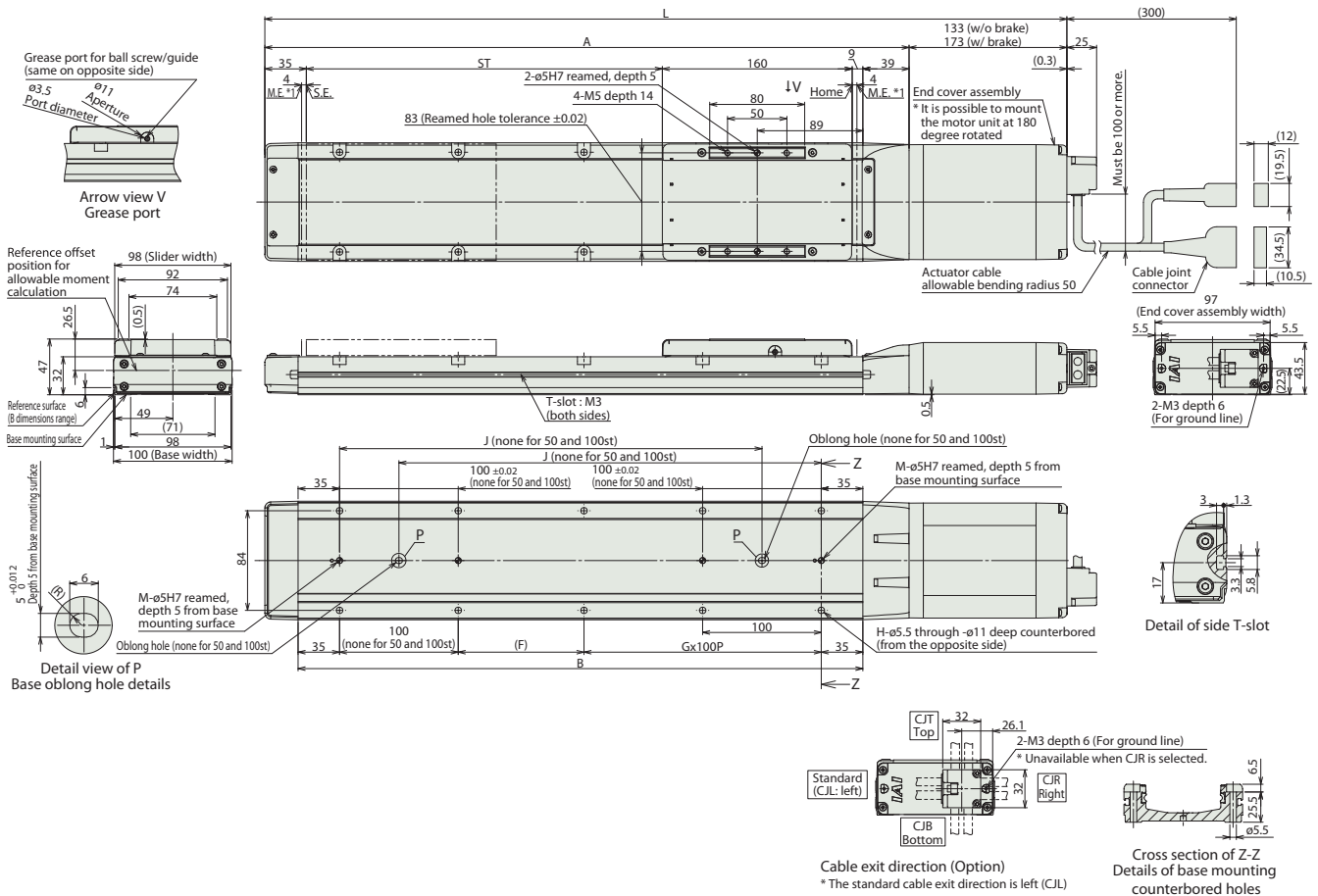

## Dimensions and Mass by Stroke

L	Stroke	50	100	150	200	250	300	350	400	450	500
	W/o brake	426	476	526	576	626	676	726	776	826	876
	W/ brake	466	516	566	616	666	716	766	816	866	916
	A	293	343	393	443	493	543	593	643	693	743
	B	226	276	326	376	426	476	526	576	626	676
	F	156	206	256	306	356	406	456	506	556	606
	G	0	0	1	1	2	2	3	3	4	4
	H	4	4	8	8	10	10	12	12	14	14
	J	-	-	206	256	306	356	406	456	506	556
	M	1	1	2	2	2	2	2	2	2	2
Mass (kg)	W/o brake	2.8	3.0	3.3	3.5	3.8	4.0	4.3	4.5	4.8	5.0
	W/ brake	3.1	3.3	3.6	3.8	4.1	4.3	4.6	4.8	5.1	5.3

## Applicable Controllers

The RCS4 series actuators can be operated by the controllers indicated below. Please select the type depending on your intended use.

Name	External view	Max. number of connectable axes	Input power	Control method				Maximum number of positioning points	Reference page	
				Positioner	Pulse train	Program	Network * Option			
SCON-CB/CGB		1	Single phase 115V/230VAC	●	●	-	DeviceNet CCLink CANopen EtherCAT EtherNet/IP Note: The type of compatible networks will vary depending on the controller. Please refer to the reference page for more information.	512 (768 for network spec.)	Please see the dedicated controller catalog or manual.	
SCON-LC/LCG (*)		1		-	-	●		512 (768 for network spec.)		
SCON-CAL/CGAL		1		●	-	-		512 (768 for network spec.)		
MSCON-C		6		This model is network-compatible only.				256		
SSEL-CS		2		●	-	●		20000		
XSEL-P/Q or XSEL-RA/SA (*)		6 or 8 (Depending on the type)	Single phase 230VAC Three-phase 230VAC	-	-	●	20000 or 55000 (Depending on the type)			

(\*) Coming soon

Foreword  
Slider Type  
Wide Slider Type  
Rod Type  
Radial Cylinder  
Wide Radial Cylinder  
Table Type  
Cleanroom Slider  
Cleanroom Wide Slider  
Options  
Reference Data  
Controller





# RCS4-WSA14C

$\pm 10\mu\text{m}$ Standard	$\pm 5\mu\text{m}$ Optional	Simple Dust-proof	Battery-less Absolute	Motor Unit Coupled	Straight Motor	Body Width <b>140mm</b>	<b>230v</b> AC Servo Motor
---------------------------------	--------------------------------	----------------------	--------------------------	-----------------------	-------------------	----------------------------	----------------------------------

Model Specification Items	<b>RCS4</b> — <b>WSA14C</b> — <b>WA</b> — <b>200</b>	Lead	Stroke	Applicable Controllers	Cable Length	Options		
Series	Type	Encoder Type	Motor Type	Lead	Stroke	Applicable Controllers	Cable Length	Options
	WA: Battery-less Absolute	200: Servo motor 200W	36:36mm 24:24mm 16:16mm 8: 8mm 4: 4mm	50:50mm 800:800mm (50mm increments)	T2:SCON MSCON SSEL XSEL-P/Q XSEL-RA/SA	N : None P : 1m S : 3m M : 5m X□□ : Specified Length R□□ : Robot Cable	Refer to Options table below. * Be sure to select an option for the cable exit direction.	

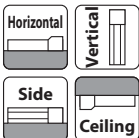

\* Depending on the model, there may be some limitations to using the vertical, side, and ceiling mount positions. Please refer to the Selection Notes on P.138 for more information.

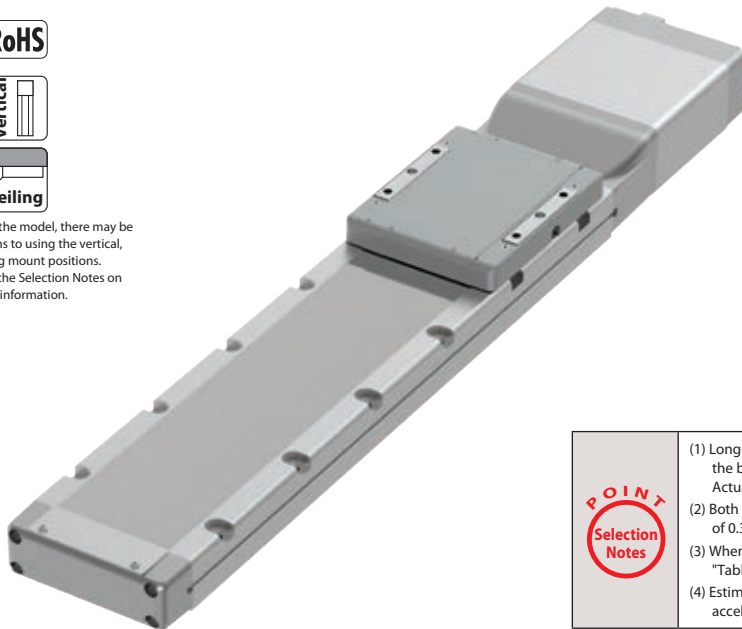

- (1) Longer strokes may cause the maximum speed to decrease due to resonance of the ball screw. Be sure to check the maximum speed of the desired stroke in the Actuator Specifications table, which can be found below.
- (2) Both the horizontal and vertical payloads assume operation at an acceleration of 0.3G.
- (3) When the acceleration is increased, the payload will be reduced. Please refer to "Table of Payload by Acceleration" on P.139 for more details.
- (4) Estimated allowable duty varies depending on operating conditions (payload, acceleration/deceleration, etc.). Please refer to P. 149 for more information.

## Actuator Specifications

### Lead and Payload

Model Number	Motor wattage (W)	Lead (mm)	Max. payload (kg)	Rated thrust (N)	Stroke (mm)	
RCS4-WSA14C-WA-200-36-①-T2-②-③	200	36	7	-	95 50~800 (50mm increments)	
RCS4-WSA14C-WA-200-24-①-T2-②-③		24	20	2.5		142
RCS4-WSA14C-WA-200-16-①-T2-②-③		16	45	8		214
RCS4-WSA14C-WA-200-8-①-T2-②-③		8	65	10		427
RCS4-WSA14C-WA-200-4-①-T2-②-③		4	80	25		855

Legend: ① Stroke ② Cable Length ③ Option

### Stroke and Max Speed

(Unit: mm/s)

Stroke	Lead							
	50~450 (50mm increments)	500 (mm)	550 (mm)	600 (mm)	650 (mm)	700 (mm)	750 (mm)	800 (mm)
36	1800			1590	1400	1240	1110	990
24	1440	1420	1220	1060	930	830	740	665
16	960	920	790	690	610	550	490	440
8	480	460	400	350	305	270	240	215
4	240	230	200	170	150	135	120	105

## Cable Length

Type	Cable Code
Standard	P (1m)
	S (3m)
	M (5m)
Specified length (Standard cable)	X06 (6m) ~ X10 (10m)
	X11 (11m) ~ X15 (15m)
	X16 (16m) ~ X20 (20m)
	R01 (1m) ~ R03 (3m)
Robot cable	R04 (4m) ~ R05 (5m)
	R06 (6m) ~ R10 (10m)
	R11 (11m) ~ R15 (15m)
	R16 (16m) ~ R20 (20m)

## Options

Name	Option Code	Reference Page
Brake	B	See P.131
Cable exit direction (Top)	CJT	See P.131
Cable exit direction (Right)	CJR	See P.131
Cable exit direction (Left)	CJL	See P.131
Cable exit direction (Bottom)	CJB	See P.131
High-precision specification (*1)	HPR	See P.134
Non-motor end specification	NM	See P.136
Slider roller specification	SR	See P.137

(\*1) When the lead is 24/36, it cannot be selected. (\*2) EU option will be available soon.

## Actuator Specifications

Item	Description
Drive system	Ball screw $\phi 12\text{mm}$ , rolled C10
Positioning repeatability (*1)	$\pm 0.01\text{mm}$ [ $\pm 0.005\text{mm}$ ]
Lost motion	0.1mm or less
Base	Material: Aluminum with white alumite treatment
Allowable static moment	Ma direction 462N·m, Mb direction 462N·m, Mc direction 1170N·m
Allowable dynamic moment (*2)	Ma direction 122N·m, Mb direction 122N·m, Mc direction 308N·m
Ambient operating temp. & humidity	0~40°C, 85% RH or less (Non-condensing)

(\*1) Values in [ ] are for high-precision (for lead 4/8/16) specification.  
(\*2) Assumes a standard rated life of 5000km. The service life will vary depending on operation and installation conditions. Please contact IAI for details of the running life.

- Reference for overhang load length: Ma: 550mm or less, Mb, Mc: 550mm or less

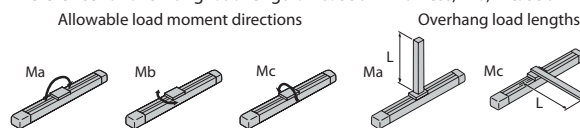

If the load moments in Ma/Mb/Mc direction are within the allowable ranges, there is no overhang load length limit.

Round cable joint connector with screw locking (*2)	EU	See P.131
---	----	-----------



## Dimensions

CAD drawings can be downloaded from our website.

www.robocylinder.de



\*1 When the slider is returning to its home position, please be careful of interference from surrounding objects, as it will travel until it reaches the M.E.  
M.E: Mechanical end S.E: Stroke end

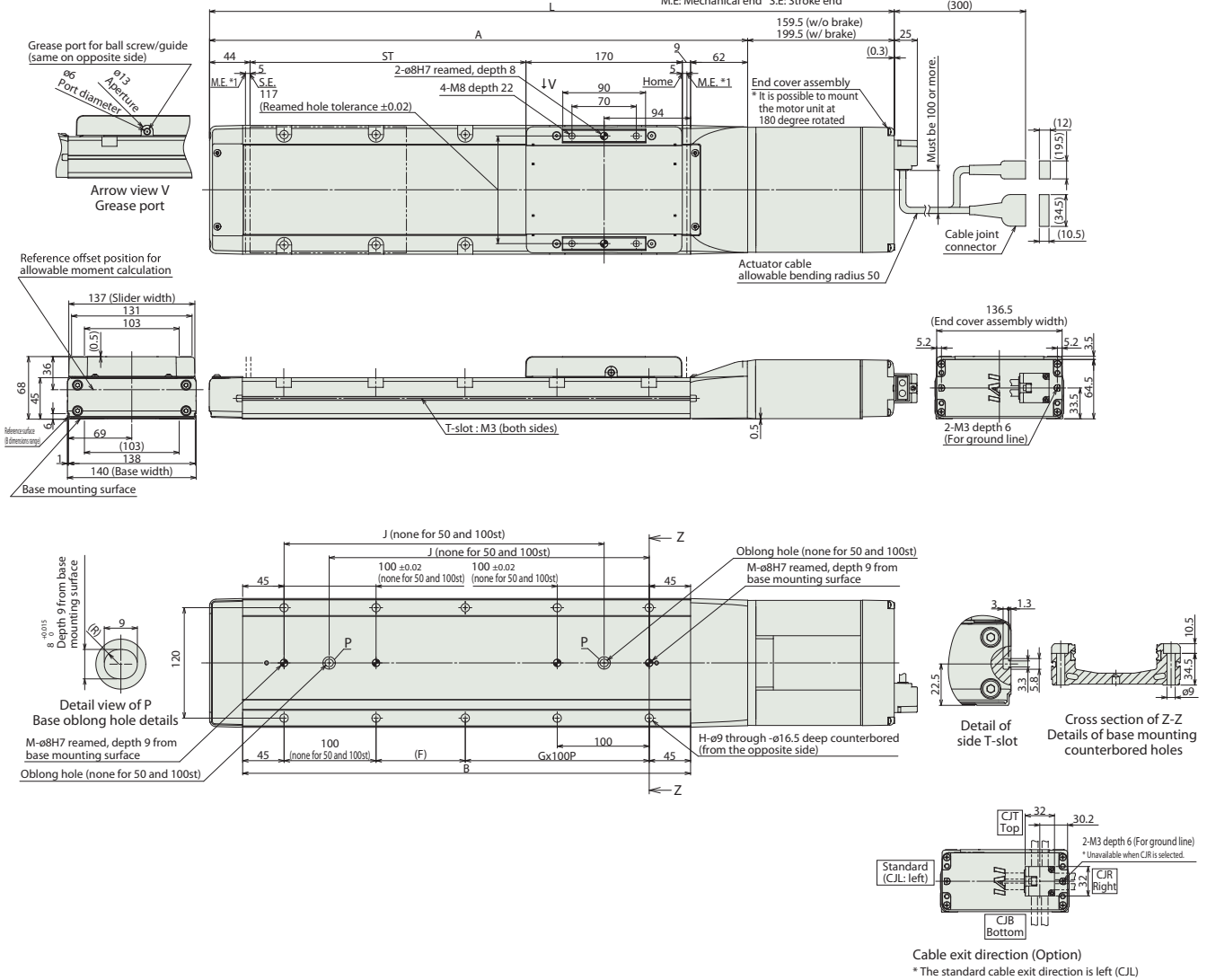

## Dimensions and Mass by Stroke

L	Stroke	50	100	150	200	250	300	350	400	450	500	550	600	650	700	750	800
	W/o brake	494.5	544.5	594.5	644.5	694.5	744.5	794.5	844.5	894.5	944.5	994.5	1044.5	1094.5	1144.5	1194.5	1244.5
W/brake	534.5	584.5	634.5	684.5	734.5	784.5	834.5	884.5	934.5	984.5	1034.5	1084.5	1134.5	1184.5	1234.5	1284.5	
A	335	385	435	485	535	585	635	685	735	785	835	885	935	985	1035	1085	
B	237	287	337	387	437	487	537	587	637	687	737	787	837	887	937	987	
F	147	197	247	297	347	397	447	497	547	597	647	697	747	797	847	897	
G	0	0	1	1	2	2	3	3	4	4	5	5	6	6	7	7	
H	4	4	8	8	10	10	12	12	14	14	16	16	18	18	20	20	
J	-	-	198	248	298	348	398	448	498	548	598	648	698	748	798	848	
M	1	1	2	2	2	2	2	2	2	2	2	2	2	2	2	2	
Mass (kg)	W/o brake	6.5	6.9	7.4	7.9	8.4	8.9	9.4	9.9	10.3	10.8	11.3	11.8	12.3	12.8	13.3	13.8
	W/brake	7.1	7.5	8.0	8.5	9.0	9.5	10.0	10.5	10.9	11.4	11.9	12.4	12.9	13.4	13.9	14.4

## Applicable Controllers

The RCS4 series actuators can be operated by the controllers indicated below. Please select the type depending on your intended use.

Name	External view	Max. number of connectable axes	Input power	Control method				Maximum number of positioning points	Reference page	
				Positioner	Pulse train	Program	Network * Option			
SCON-CB/CGB		1	Single phase 115V/230VAC	●	●	-	DeviceNet CCLink PROFINET EtherCAT EtherNet/IP	512 (768 for network spec.)	Please see P.151	
SCON-LC/LCG (*)		1		-	-	●		512 (768 for network spec.)		
SCON-CAL/CGAL		1		●	-	-		512 (768 for network spec.)		
MSCON-C		6		This model is network-compatible only.				256		
SSEL-CS		2		●	-	●		20000		
XSEL-P/Q or XSEL-RA/SA (*)		6 or 8 (Depending on the type)	Single phase 230VAC Three-phase 230VAC	-	-	●	20000 or 55000 (Depending on the type)	Please see the dedicated controller catalog or manual.		
Note: The type of compatible networks will vary depending on the controller. Please refer to the reference page for more information.										

(\*) Coming soon

Foreword  
 Slider Type  
 Wide Slider Type  
 Rod Type  
 Radial Cylinder  
 Wide Radial Cylinder  
 Table Type  
 Cleanroom Slider  
 Cleanroom Wide Slider  
 Options  
 Reference Data  
 Controller

# RCS4-WSA16C

$\pm 10\mu\text{m}$ Standard	$\pm 5\mu\text{m}$ Optional	Simple Dust-proof	Battery-less Absolute	Motor Unit Coupled	Straight Motor	Body Width <b>160</b> mm	<b>230v</b> AC Servo Motor
---------------------------------	--------------------------------	----------------------	--------------------------	-----------------------	-------------------	--------------------------------	----------------------------------

<b>Model Specification Items</b>	<b>RCS4</b> — <b>WSA16C</b> — <b>WA</b> — <b>400</b> — <b>T2</b>							
Series	Type	Encoder Type	Motor Type	Lead	Stroke	Applicable Controllers	Cable Length	Options
	WA: Battery-less Absolute	400: Servo motor 400W	30:30mm 20:20mm 10:10mm 5: 5mm	50:50mm 1100:1100mm (50mm increments)	T2:SCON SSEL XSEL-P/Q XSEL-RA/SA	N : None P : 1m S : 3m M : 5m	X□ : Specified Length R□ : Robot Cable	Refer to Options table below. * Be sure to select an option for the cable exit direction.

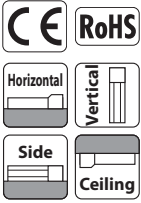

\* Depending on the model, there may be some limitations to using the vertical, side, and ceiling mount positions. Please refer to the Selection Notes on P.138 for more information.

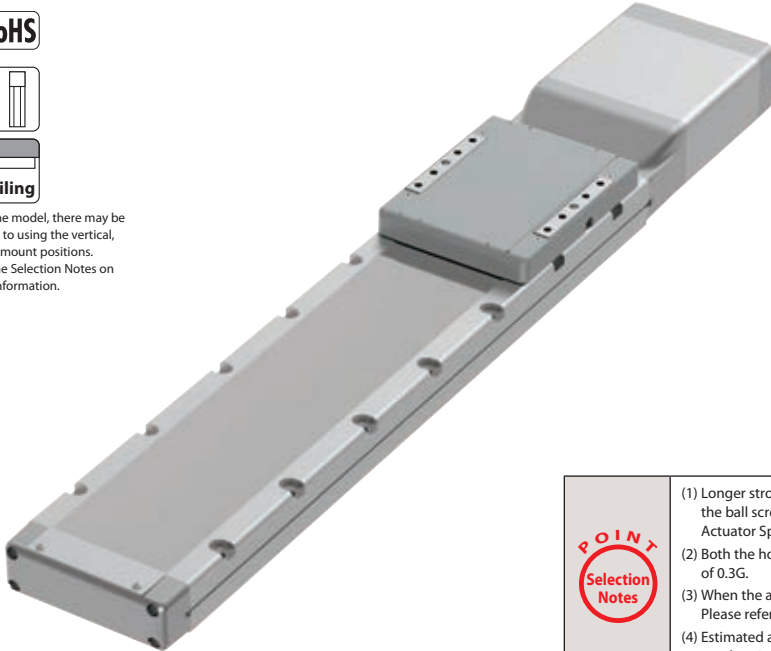

**POINT Selection Notes**

- (1) Longer strokes may cause the maximum speed to decrease due to resonance of the ball screw. Be sure to check the maximum speed of the desired stroke in the Actuator Specifications table, which can be found below.
- (2) Both the horizontal and vertical payloads assume operation at an acceleration of 0.3G.
- (3) When the acceleration is increased, the payload will be reduced. Please refer to "Table of Payload by Acceleration" on P.139 for more details.
- (4) Estimated allowable duty varies depending on operating conditions (payload, acceleration/deceleration, etc.). Please refer to P. 149 for more information.

## Actuator Specifications

### Lead and Payload

Model Number	Motor wattage (W)	Lead (mm)	Max. payload		Rated thrust (N)	Stroke (mm)
			Horizontal (kg)	Vertical (kg)		
RCS4-WSA16C-WA-400-30-①-T2-②-③	400	30	30	12	226	50~1100 (50mm increments)
RCS4-WSA16C-WA-400-20-①-T2-②-③		20	60	20	339	
RCS4-WSA16C-WA-400-10-①-T2-②-③		10	80	35	678	
RCS4-WSA16C-WA-400-5-①-T2-②-③		5	100	50	1357	

Legend: ① Stroke ② Cable Length ③ Option

### Stroke and Max Speed

Stroke	Max Speed (Unit: mm/s)											
	50~550 (50mm increments)	600	650	700	750	800	850	900	950	1000	1050	1100
30	1800	1680	1480	1320	1180	1060	960	870	790	730	670	620
20	1200	1120	990	880	780	715	645	590	535	490	450	415
10	600	560	490	440	395	355	320	290	265	240	225	205
5	300	280	240	220	195	175	160	145	130	120	110	100

## Cable Length

Type	Cable Code
Standard	P (1m)
	S (3m)
	M (5m)
Specified length (Standard cable)	X06 (6m) ~ X10 (10m)
	X11 (11m) ~ X15 (15m)
	X16 (16m) ~ X20 (20m)
	R01 (1m) ~ R03 (3m)
	R04 (4m) ~ R05 (5m)
Robot cable	R06 (6m) ~ R10 (10m)
	R11 (11m) ~ R15 (15m)
	R16 (16m) ~ R20 (20m)

## Options

Name	Option Code	Reference Page
Brake	B	See P.131
Cable exit direction (Top)	CJT	See P.131
Cable exit direction (Right)	CJR	See P.131
Cable exit direction (Left)	CJL	See P.131
Cable exit direction (Bottom)	CJB	See P.131
High-precision specification (*1)	HPR	See P.134
Non-motor end specification	NM	See P.136
Slider roller specification	SR	See P.137

(\*1) When the lead is 30, it cannot be selected. (\*2) EU option will be available soon.

## Actuator Specifications

Item	Description
Drive system	Ball screw $\phi 16\text{mm}$ , rolled C10
Positioning repeatability (*1)	$\pm 0.01\text{mm}$ [ $\pm 0.005\text{mm}$ ]
Lost motion	0.1mm or less
Base	Material: Aluminum with white alumite treatment
Allowable static moment	Ma direction 642N·m, Mb direction 642N·m, Mc direction 1610N·m
Allowable dynamic moment (*2)	Ma direction 161N·m, Mb direction 161N·m, Mc direction 404N·m
Ambient operating temp. & humidity	0~40°C, 85% RH or less (Non-condensing)

(\*1) Values in [ ] are for high-precision (for lead 5/10/20) specification.  
(\*2) Assumes a standard rated life of 5000km. The service life will vary depending on operation and installation conditions. Please contact IAI for details of the running life.

• Reference for overhang load length: Ma: 650mm or less, Mb, Mc: 650mm or less

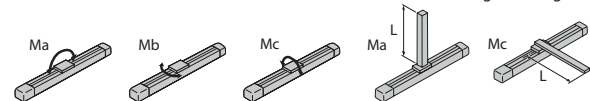

If the load moments in Ma/Mb/Mc direction are within the allowable ranges, there is no overhang load length limit.

Round cable joint connector with screw locking (*2)	EU	See P.131
---	----	-----------

## Dimensions

CAD drawings can be downloaded from our website.  
www.robocylinder.de



\*1 When the slider is returning to its home position, please be careful of interference from surrounding objects, as it will travel until it reaches the M.E.  
M.E: Mechanical end S.E: Stroke end

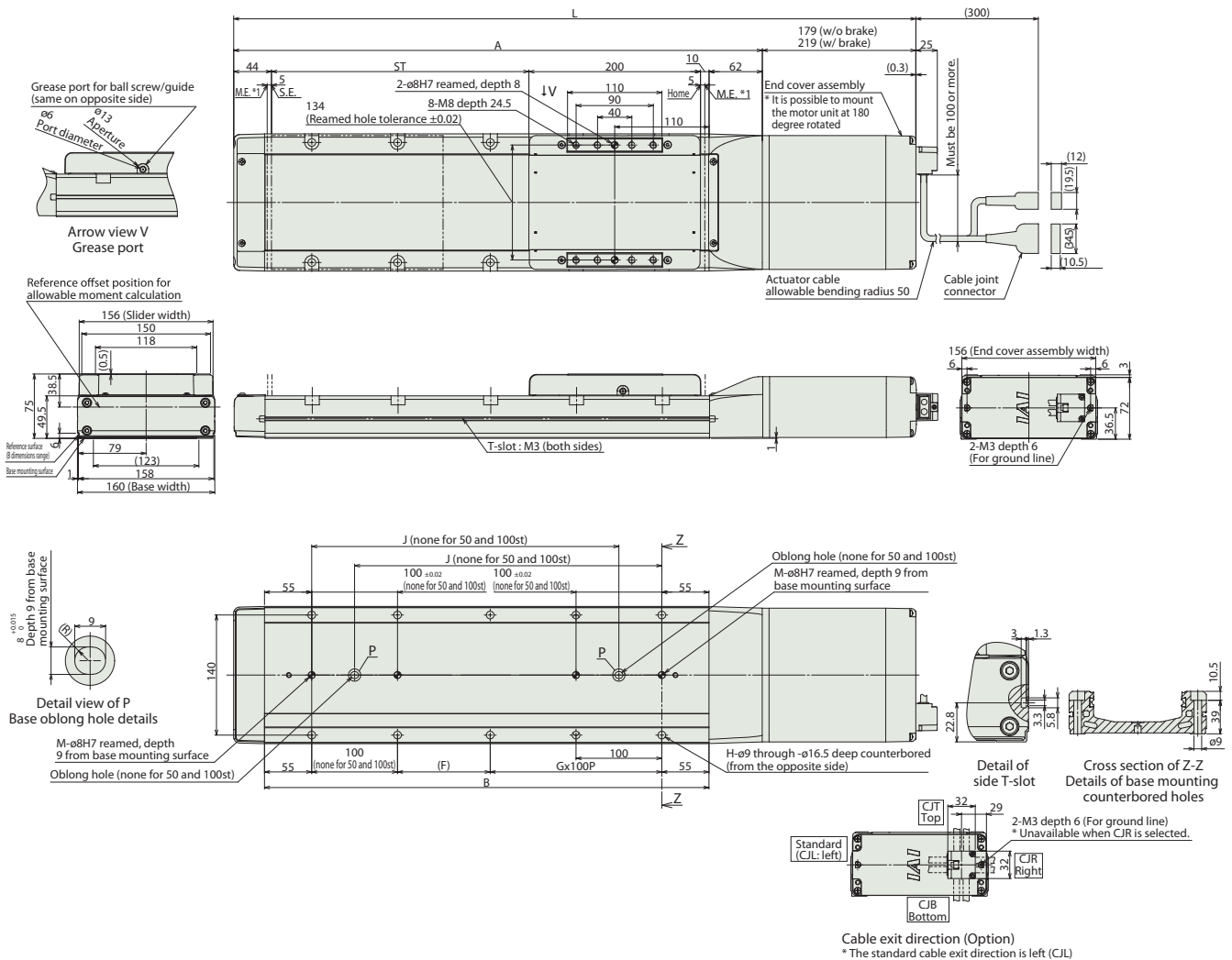

## Dimensions and Mass by Stroke

L	Stroke	50	100	150	200	250	300	350	400	450	500	550	600	650	700	750	800	850	900	950	1000	1050	1100
	W/o brake	545	595	645	695	745	795	845	895	945	995	1045	1095	1145	1195	1245	1295	1345	1395	1445	1495	1545	1595
W/ brake	585	635	685	735	785	835	885	935	985	1035	1085	1135	1185	1235	1285	1335	1385	1435	1485	1535	1585	1635	
A	366	416	466	516	566	616	666	716	766	816	866	916	966	1016	1066	1116	1166	1216	1266	1316	1366	1416	
B	268	318	368	418	468	518	568	618	668	718	768	818	868	918	968	1018	1068	1118	1168	1218	1268	1318	
F	158	208	258	308	358	408	458	508	558	608	658	708	758	808	858	908	958	1008	1058	1108	1158		
G	0	0	1	1	2	2	3	3	4	4	5	5	6	6	7	7	8	8	9	9	10	10	
H	4	4	8	8	10	10	12	12	14	14	16	16	18	18	20	20	22	22	24	24	26	26	
J	-	-	208	258	308	358	408	458	508	558	608	658	708	758	808	858	908	958	1008	1058	1108	1158	
M	1	1	2	2	2	2	2	2	2	2	2	2	2	2	2	2	2	2	2	2	2	2	
Mass (kg)	W/o brake	9.1	9.8	10.4	11.0	11.6	12.2	12.8	13.4	14.0	14.7	15.3	15.9	16.5	17.1	17.7	18.3	18.9	19.6	20.2	20.8	21.4	22.0
	W/ brake	9.7	10.4	11.0	11.6	12.2	12.8	13.4	14.0	14.6	15.3	15.9	16.5	17.1	17.7	18.3	18.9	19.5	20.2	20.8	21.4	22.0	22.6

## Applicable Controllers

The RCS4 series actuators can be operated by the controllers indicated below. Please select the type depending on your intended use.

Name	External view	Max. number of connectable axes	Input power	Control method				Maximum number of positioning points	Reference page
				Positioner	Pulse train	Program	Network * Option		
SCON-CB/CGB		1	Single phase 230VAC	●	●	-	DeviceNet CC-Link	512 (768 for network spec.)	Please see P.151
SCON-LC/LCG (*)		1		-	-	●	CompoNet EtherCAT EtherNet/IP		
SSEL-CS		2	Single phase 115V/230VAC	●	-	●	20000	Please see the dedicated controller catalog or manual.	
XSEL-P/Q or XSEL-RA/SA (*)		6 or 8 (Depending on the type)	Single phase 230VAC Three-phase 230VAC	-	-	●	20000 or 55000 (Depending on the type)		

Note: The type of compatible networks will vary depending on the controller. Please refer to the reference page for more information.

(\*) Coming soon

Foreword  
Slider Type  
Wide Slider Type  
Rod Type  
Radial Cylinder  
Wide Radial Cylinder  
Table Type  
Cleanroom Slider  
Cleanroom Wide Slider  
Options  
Reference Data  
Controller

# RCS4-WSA10R



±10μm  
Standard



Simple  
Dust-proof



Battery-less  
Absolute



Motor  
Unit  
Coupled



Side-mounted  
Motor



Body Width  
100\*  
mm



230v  
AC Servo  
Motor

<b>Model Specification Items</b>	<b>RCS4</b> — <b>WSA10R</b> — <b>WA</b> — <b>60</b> — <span style="border: 1px solid black; display: inline-block; width: 15px; height: 15px;"></span> — <span style="border: 1px solid black; display: inline-block; width: 15px; height: 15px;"></span> — <b>T2</b> — <span style="border: 1px solid black; display: inline-block; width: 15px; height: 15px;"></span> — <span style="border: 1px solid black; display: inline-block; width: 15px; height: 15px;"></span>	Series — Type — Encoder Type — Motor Type		Lead	Stroke	Applicable Controllers	Cable Length	Options	* Body width does not include the width of the side-mounted motor.
	WA: Battery-less Absolute	60: Servo motor 60W	16: 16mm 10: 10mm 5: 5mm 2.5: 2.5mm	50: 50mm + 500: 500mm (50mm increments)	T2: SCON MSCON SSEL XSEL-P/Q XSEL-RA/SA	N: None P: 1m S: 3m M: 5m X□□: Specified Length R□□: Robot Cable	Refer to Options table below.		

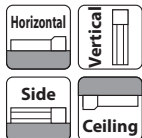

\* Depending on the model, there may be some limitations to using the vertical, side, and ceiling mount positions. Please refer to the Selection Notes on P.138 for more information.

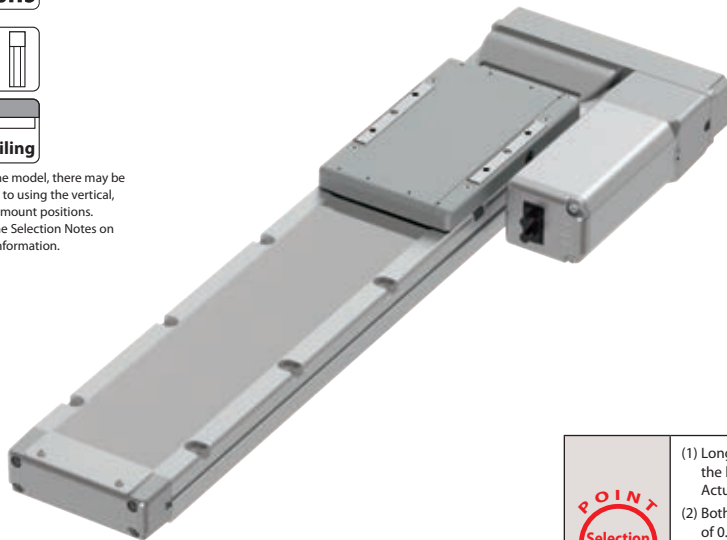

POINT Selection Notes

- (1) Longer strokes may cause the maximum speed to decrease due to resonance of the ball screw. Be sure to check the maximum speed of the desired stroke in the Actuator Specifications table, which can be found below.
- (2) Both the horizontal and vertical payloads assume operation at an acceleration of 0.3G.
- (3) When the acceleration is increased, the payload will be reduced. Please refer to "Table of Payload by Acceleration" on P.139 for more details.
- (4) Estimated allowable duty varies depending on operating conditions (payload, acceleration/deceleration, etc.). Please refer to P. 149 for more information.

## Actuator Specifications

### Lead and Payload

Model Number	Motor wattage (W)	Lead (mm)	Max. payload		Rated thrust (N)	Stroke (mm)
			Horizontal (kg)	Vertical (kg)		
RCS4-WSA10R-WA-60-16-①-T2-②-③	60	16	7	—	53	50~500 (50mm increments)
RCS4-WSA10R-WA-60-10-①-T2-②-③		10	16	3	85	
RCS4-WSA10R-WA-60-5-①-T2-②-③		5	27	5	170	
RCS4-WSA10R-WA-60-2.5-①-T2-②-③		2.5	40	10	340	

Legend: ① Stroke ② Cable Length ③ Option

### Stroke and Max Speed

Lead	Stroke (50mm increments)	Max Speed (Unit: mm/s)		
		400 (mm)	450 (mm)	500 (mm)
16	960	930	775	660
10	600	590	490	415
5	300	290	245	205
2.5	150	145	120	100

## Cable Length

Type	Cable Code
Standard	P (1m)
	S (3m)
	M (5m)
Specified length (Standard cable)	X06 (6m) ~ X10 (10m)
	X11 (11m) ~ X15 (15m)
	X16 (16m) ~ X20 (20m)
	R01 (1m) ~ R03 (3m)
Robot cable	R04 (4m) ~ R05 (5m)
	R06 (6m) ~ R10 (10m)
	R11 (11m) ~ R15 (15m)
	R16 (16m) ~ R20 (20m)
	R16 (16m) ~ R20 (20m)

## Actuator Specifications

Item	Description
Drive system	Ball screw ø8mm, rolled C10
Positioning repeatability	±0.01mm
Lost motion	0.1mm or less
Base	Material: Aluminum with white alumite treatment
Allowable static moment	Ma direction 271N-m, Mb direction 271N-m, Mc direction 553N-m
Allowable dynamic moment (*1)	Ma direction 65.4N-m, Mb direction 65.4N-m, Mc direction 134N-m
Ambient operating temp. & humidity	0~40°C, 85% RH or less (Non-condensing)

(\*1) Assumes a standard rated life of 5000km. The service life will vary depending on operation and installation conditions. Please contact IAI for details of the running life.

- Reference for overhang load length: Ma: 500mm or less, Mb, Mc: 500mm or less

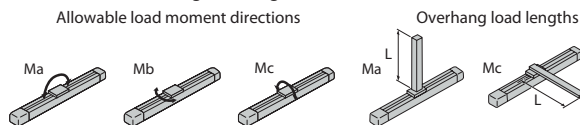

If the load moments in Ma/Mb/Mc direction are within the allowable ranges, there is no overhang load length limit.

## Options

Name	Option Code	Reference Page
Brake	B	See P.131
Cable exit direction (Top)	CJT	See P.131
Cable exit direction (Bottom)	CJB	See P.131
Cable exit direction (Outside)	CJO	See P.131
Motor side-mounted to left (standard)	ML	See P.135
Motor side-mounted to right	MR	See P.135
Non-motor end specification	NM	See P.136
Slider roller specification	SR	See P.137
Slider spacer	SS	See P.137

(\*1) EU option will be available soon.

Round cable joint connector with screw locking (*1)	<b>EU</b>	See P.131
---	-----------	-----------

## Dimensions

CAD drawings can be downloaded from our website.  
[www.robocylinder.de](http://www.robocylinder.de)



\*1 When the slider is returning to its home position, please be careful of interference from surrounding objects, as it will travel until it reaches the M.E.  
 M.E: Mechanical end S.E: Stroke end

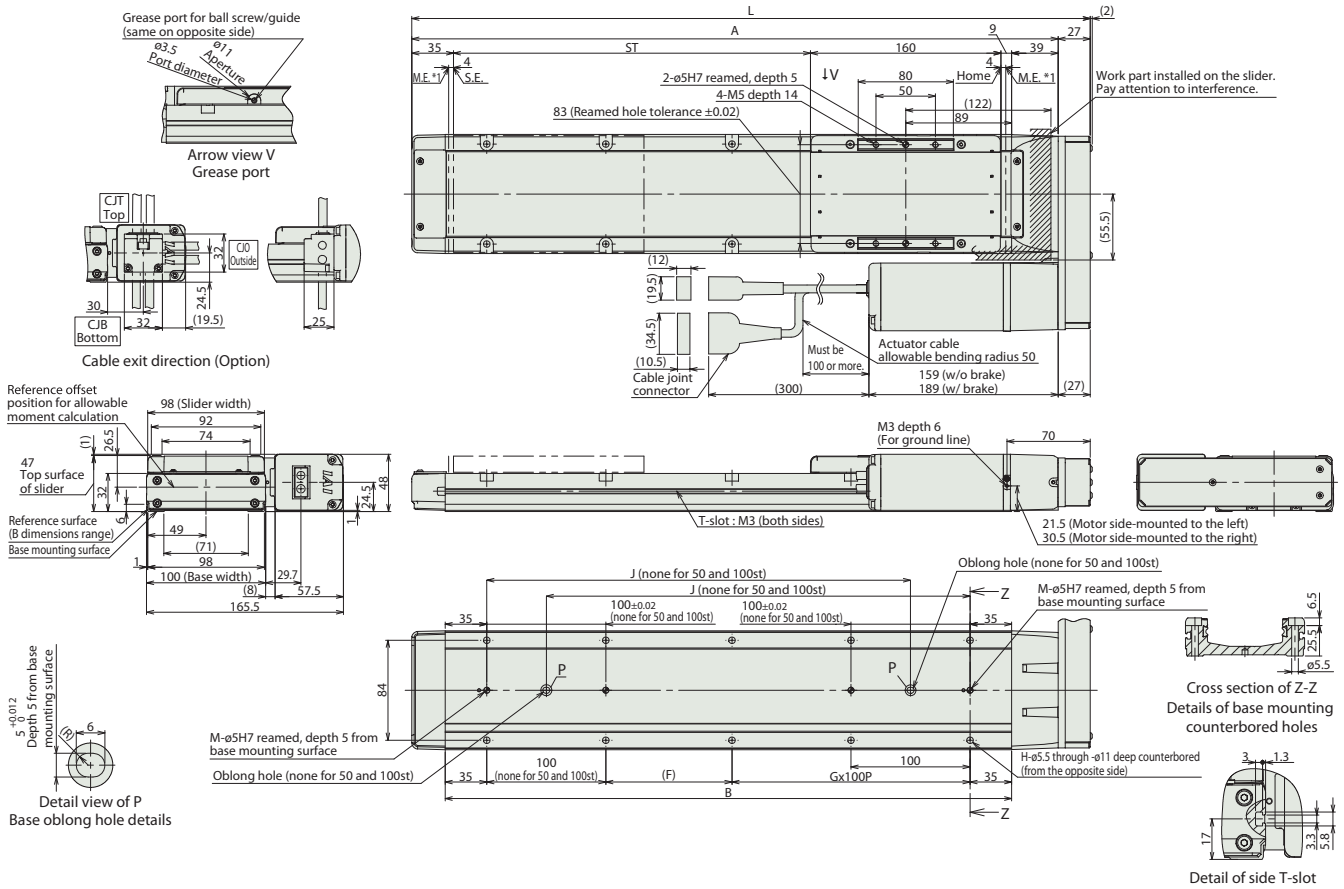

### Dimensions and Mass by Stroke

Stroke	50	100	150	200	250	300	350	400	450	500
L	320	370	420	470	520	570	620	670	720	770
A	293	343	393	443	493	543	593	643	693	743
B	226	276	326	376	426	476	526	576	626	676
F	156	206	256	306	356	406	456	506	556	606
G	0	0	1	1	2	2	3	3	4	4
H	4	4	8	8	10	10	12	12	14	14
J	-	-	206	256	306	356	406	456	506	556
M	1	1	2	2	2	2	2	2	2	2
Mass (kg)	W/o brake	3.2	3.5	3.7	4.0	4.2	4.5	4.7	4.9	5.2
	W/brake	3.5	3.8	4.0	4.3	4.5	4.8	5.0	5.2	5.5

### Applicable Controllers

The RCS4 series actuators can be operated by the controllers indicated below. Please select the type depending on your intended use.

Name	External view	Max. number of connectable axes	Input power	Control method				Maximum number of positioning points	Reference page	
				Positioner	Pulse train	Program	Network * Option			
SCON-CB/CGB		1	Single phase 115V/230VAC	●	●	-	DeviceNet CC-Link CANopen EtherCAT EtherNet/IP Note: The type of compatible networks will vary depending on the controller. Please refer to the reference page for more information.	512 (768 for network spec.)	Please see P.151	
SCON-LC/LCG (*)		1		-	-	●		512 (768 for network spec.)		
SCON-CAL/CGAL		1		●	-	-		512 (768 for network spec.)		
MSCON-C		6		This model is network-compatible only.				256		
SSEL-CS		2		●	-	●		20000		
XSEL-P/Q or XSEL-RA/SA (*)		6 or 8 (Depending on the type)	Single phase 230VAC Three-phase 230VAC	-	-	●	20000 or 55000 (Depending on the type)	Please see the dedicated controller catalog or manual.		

(\*) Coming soon

Foreword  
 Slider Type  
 Wide Slider Type  
 Rod Type  
 Radial Cylinder  
 Wide Radial Cylinder  
 Table Type  
 Cleanroom Slider  
 Cleanroom Wide Slider

Options

Reference Data

Controller

# RCS4-WSA12R

±10μm  
Standard

Simple  
Dust-  
proof

Battery-  
less  
Absolute

Motor  
Unit  
Coupled

Side-mounted  
Motor

Body Width  
**120\***  
mm

**230v**  
AC Servo  
Motor

<b>Model Specification Items</b>	<b>RCS4</b> — <b>WSA12R</b> — <b>WA</b> — <b>100</b> — <span style="border: 1px solid black; display: inline-block; width: 15px; height: 15px;"></span> — <span style="border: 1px solid black; display: inline-block; width: 15px; height: 15px;"></span> — <b>T2</b> — <span style="border: 1px solid black; display: inline-block; width: 15px; height: 15px;"></span> — <span style="border: 1px solid black; display: inline-block; width: 15px; height: 15px;"></span>	<b>Series</b> — <b>Type</b> — <b>Encoder Type</b> — <b>Motor Type</b> — <b>Lead</b> — <b>Stroke</b> — <b>Applicable Controllers</b> — <b>Cable Length</b> — <b>Options</b>		<b>* Body width does not include the width of the side-mounted motor.</b>		
	WA: Battery-less Absolute	100: Servo motor 100W	30:30mm 20:20mm 12:12mm 6: 6mm 3: 3mm	50:50mm + 800:800mm (50mm increments)	T2:SCON MSCON SSEL XSEL-P/Q XSEL-RA/SA	N : None P : 1m S : 3m M : 5m X□□ : Specified Length R□□ : Robot Cable

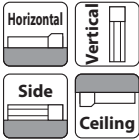

\* Depending on the model, there may be some limitations to using the vertical, side, and ceiling mount positions. Please refer to the Selection Notes on P.138 for more information.

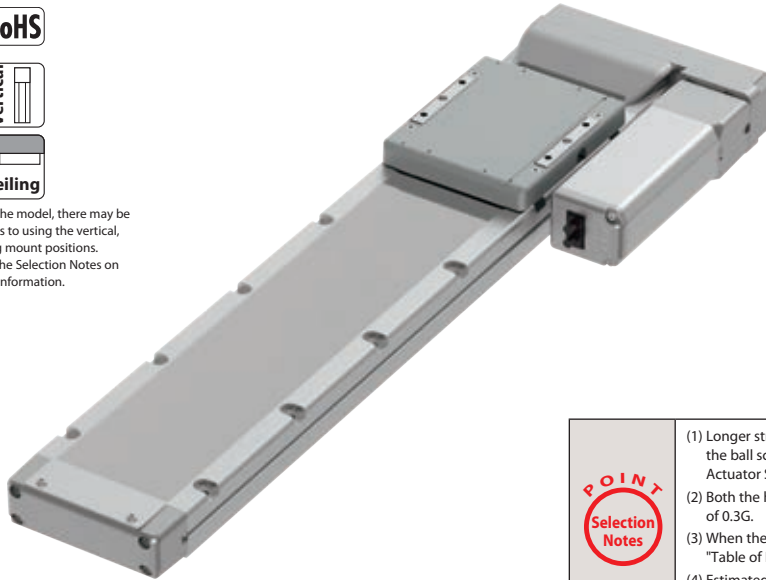

- (1) Longer strokes may cause the maximum speed to decrease due to resonance of the ball screw. Be sure to check the maximum speed of the desired stroke in the Actuator Specifications table, which can be found below.
- (2) Both the horizontal and vertical payloads assume operation at an acceleration of 0.3G.
- (3) When the acceleration is increased, the payload will be reduced. Please refer to "Table of Payload by Acceleration" on P.139 for more details.
- (4) Estimated allowable duty varies depending on operating conditions (payload, acceleration/deceleration, etc.). Please refer to P. 149 for more information.

## Actuator Specifications

### Lead and Payload

Model Number	Motor wattage (W)	Lead (mm)	Max. payload		Rated thrust (N)	Stroke (mm)
			Horizontal (kg)	Vertical (kg)		
RCS4-WSA12R-WA-100-30-①-T2-②-③	100	30	5	—	57	50~800 (50mm increments)
RCS4-WSA12R-WA-100-20-①-T2-②-③		20	13	3	85	
RCS4-WSA12R-WA-100-12-①-T2-②-③		12	23	8	142	
RCS4-WSA12R-WA-100-6-①-T2-②-③		6	43	15	283	
RCS4-WSA12R-WA-100-3-①-T2-②-③		3	55	15	566	

Legend: ① Stroke ② Cable Length ③ Option

### Stroke and Max Speed

(Unit: mm/s)

Stroke / Lead	50~450	500	550	600	650	700	750	800
	(50mm increments)	(mm)	(mm)	(mm)	(mm)	(mm)	(mm)	(mm)
30	1600	1450	1260	1100	970	860	770	
20	1200	1130	970	840	740	650	580	520
12	720	610	535	465	405	355	315	285
6	360	310	265	230	200	175	155	140
3	180	150	130	115	100	85	75	70

## Cable Length

Type	Cable Code
Standard	<b>P</b> (1m)
	<b>S</b> (3m)
	<b>M</b> (5m)
Specified length (Standard cable)	<b>X06</b> (6m) ~ <b>X10</b> (10m)
	<b>X11</b> (11m) ~ <b>X15</b> (15m)
	<b>X16</b> (16m) ~ <b>X20</b> (20m)
	<b>R01</b> (1m) ~ <b>R03</b> (3m)
Robot cable	<b>R04</b> (4m) ~ <b>R05</b> (5m)
	<b>R06</b> (6m) ~ <b>R10</b> (10m)
	<b>R11</b> (11m) ~ <b>R15</b> (15m)
	<b>R16</b> (16m) ~ <b>R20</b> (20m)

## Actuator Specifications

Item	Description
Drive system	Ball screw ø10mm, rolled C10
Positioning repeatability	±0.01mm
Lost motion	0.1mm or less
Base	Material: Aluminum with white alumite treatment
Allowable static moment	Ma direction 311N·m, Mb direction 311N·m, Mc direction 827N·m
Allowable dynamic moment (*1)	Ma direction 87.5N·m, Mb direction 87.5N·m, Mc direction 233N·m
Ambient operating temp. & humidity	0~40°C, 85% RH or less (Non-condensing)

(\*1) Assumes a standard rated life of 5000km. The service life will vary depending on operation and installation conditions. Please contact IAI for details of the running life.

• Reference for overhang load length: Ma: 450mm or less, Mb, Mc: 450mm or less

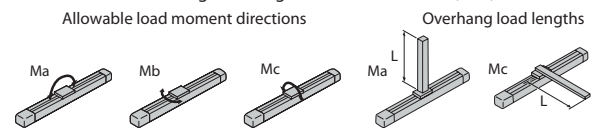

If the load moments in Ma/Mb/Mc direction are within the allowable ranges, there is no overhang load length limit.

## Options

Name	Option Code	Reference Page
Brake	<b>B</b>	See P.131
Cable exit direction (Top)	<b>CJT</b>	See P.131
Cable exit direction (Bottom)	<b>CJB</b>	See P.131
Cable exit direction (Outside)	<b>CJO</b>	See P.131
Motor side-mounted to left (standard)	<b>ML</b>	See P.135
Motor side-mounted to right	<b>MR</b>	See P.135
Non-motor end specification	<b>NM</b>	See P.136
Slider roller specification	<b>SR</b>	See P.137

(\*1) EU option will be available soon.

Round cable joint connector with screw locking (*1)	<b>EU</b>	See P.131
---	-----------	-----------

## Dimensions

CAD drawings can be downloaded from our website.  
[www.robocylinder.de](http://www.robocylinder.de)



\*1 When the slider is returning to its home position, please be careful of interference from surrounding objects, as it will travel until it reaches the M.E.  
 M.E: Mechanical end S.E: Stroke end

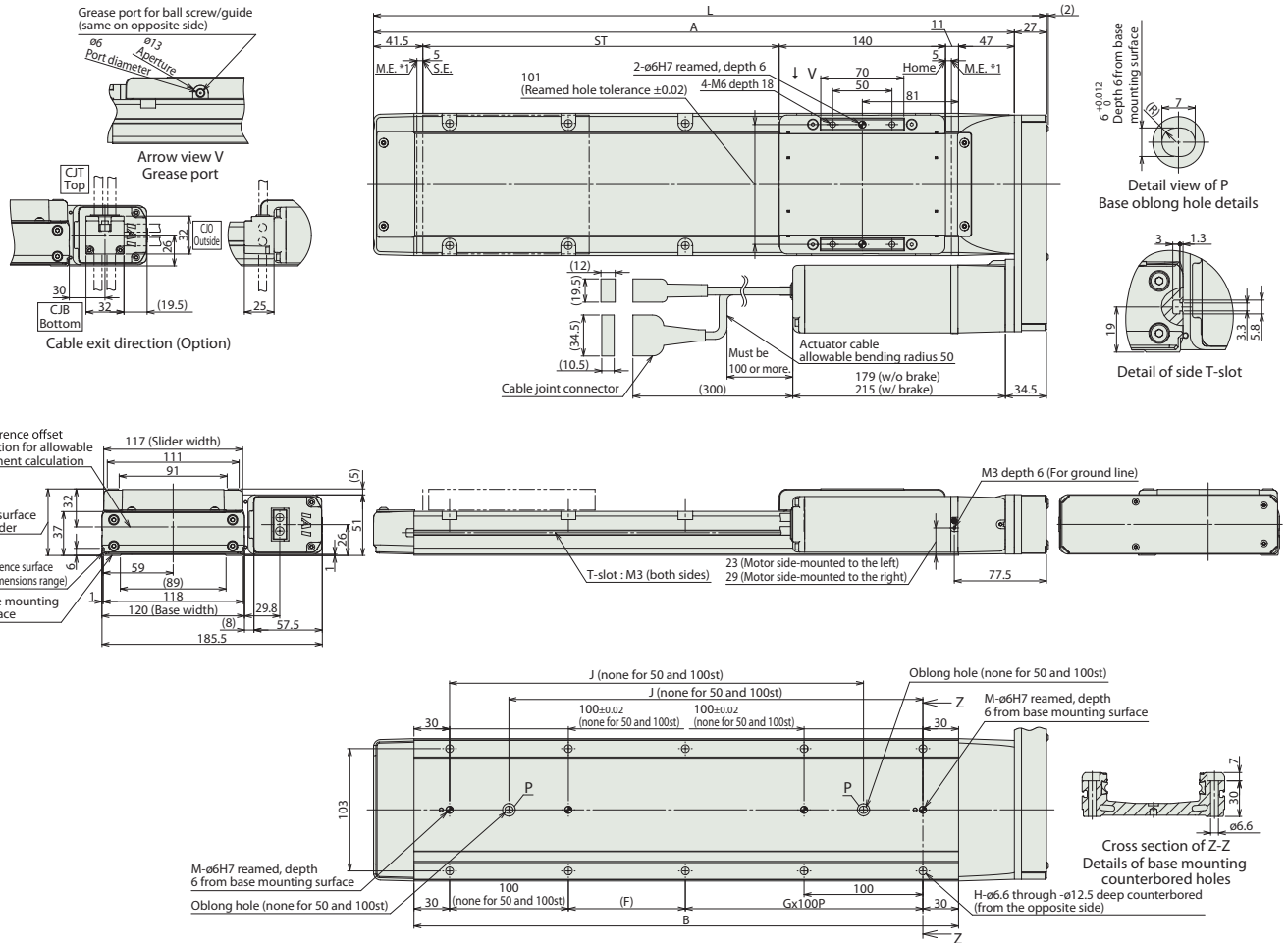

Foreword  
 Slider Type  
 Wide Slider Type  
 Rod Type  
 Radial Cylinder  
 Wide Radial Cylinder  
 Table Type  
 Cleanroom Slider  
 Cleanroom Wide Slider  
 Options  
 Reference Data  
 Controller

### ■ Dimensions and Mass by Stroke

Stroke	50	100	150	200	250	300	350	400	450	500	550	600	650	700	750	800
L	316.5	366.5	416.5	466.5	516.5	566.5	616.5	666.5	716.5	766.5	816.5	866.5	916.5	966.5	1016.5	1066.5
A	289.5	339.5	389.5	439.5	489.5	539.5	589.5	639.5	689.5	739.5	789.5	839.5	889.5	939.5	989.5	1039.5
B	208.5	258.5	308.5	358.5	408.5	458.5	508.5	558.5	608.5	658.5	708.5	758.5	808.5	858.5	908.5	958.5
F	148.5	198.5	248.5	298.5	348.5	398.5	448.5	498.5	548.5	598.5	648.5	698.5	748.5	798.5	848.5	898.5
G	0	0	1	1	2	2	3	3	4	4	5	5	6	6	7	7
H	4	4	8	8	10	10	12	12	14	14	16	16	18	18	20	20
J	-	-	198.5	248.5	298.5	348.5	398.5	448.5	498.5	548.5	598.5	648.5	698.5	748.5	798.5	848.5
M	1	1	2	2	2	2	2	2	2	2	2	2	2	2	2	2
Mass (kg)	W/o brake	4.2	4.5	4.9	5.2	5.6	5.9	6.2	6.6	6.9	7.2	7.6	7.9	8.3	8.6	8.9
	W/brake	4.5	4.8	5.2	5.5	5.9	6.2	6.5	6.9	7.2	7.5	7.9	8.2	8.6	8.9	9.2

### ■ Applicable Controllers

The RCS4 series actuators can be operated by the controllers indicated below. Please select the type depending on your intended use.

Name	External view	Max. number of connectable axes	Input power	Control method				Maximum number of positioning points	Reference page	
				Positioner	Pulse train	Program	Network * Option			
SCON-CB/CGB		1	Single phase 115V/230VAC	●	●	-	DeviceNet CC-Link CANopen EtherCAT EtherNet/IP	512 (768 for network spec.)	Please see the dedicated controller catalog or manual.	
SCON-LC/LCG (*)		1		-	-	●		512 (768 for network spec.)		
SCON-CAL/CGAL		1		●	-	-		512 (768 for network spec.)		
MSCON-C		6		This model is network-compatible only.				256		
SSEL-CS		2		●	-	●		20000		
XSEL-P/Q or XSEL-RA/SA (*)		6 or 8 (Depending on the type)	Single phase 230VAC Three-phase 230VAC	-	-	●	20000 or 55000 (Depending on the type)			

(\*) Coming soon

# RCS4-WSA14R

±10μm  
Standard

Simple  
Dust-  
proof

Battery-  
less  
Absolute

Motor  
Unit  
Coupled

Side-mounted  
Motor

Body Width  
**140\***  
mm

**230v**  
AC Servo  
Motor

<b>Model Specification Items</b>	<b>RCS4</b> — <b>WSA14R</b> — <b>WA</b> — <b>200</b> — <span style="border: 1px solid black; display: inline-block; width: 15px; height: 15px;"></span> — <span style="border: 1px solid black; display: inline-block; width: 15px; height: 15px;"></span> — <b>T2</b> — <span style="border: 1px solid black; display: inline-block; width: 15px; height: 15px;"></span> — <span style="border: 1px solid black; display: inline-block; width: 15px; height: 15px;"></span>	* Body width does not include the width of the side-mounted motor.	
	Series — Type — Encoder Type — Motor Type — Lead — Stroke — Applicable Controllers — Cable Length — Options	WA: Battery-less Absolute      200: Servo motor 200W      36:36mm 24:24mm 16:16mm 8: 8mm 4: 4mm	50:50mm + 800:800mm (50mm increments)

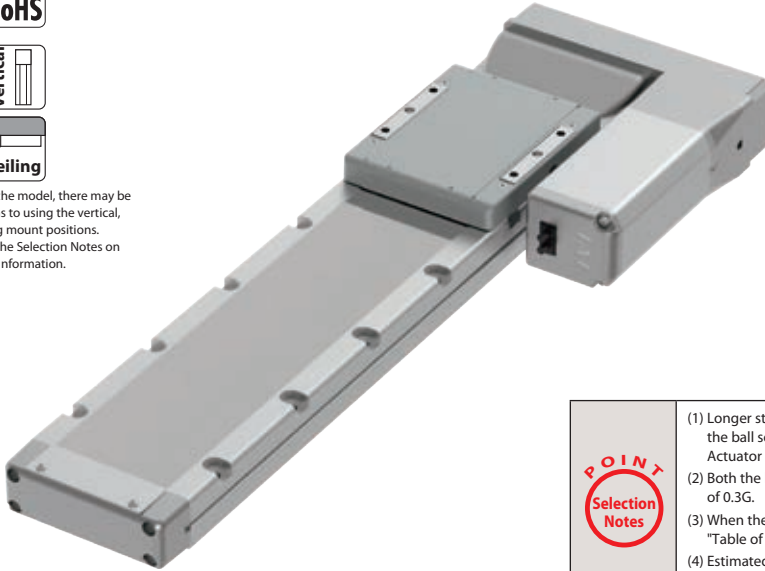
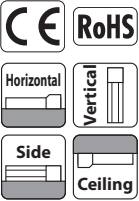

\* Depending on the model, there may be some limitations to using the vertical, side, and ceiling mount positions. Please refer to the Selection Notes on P.138 for more information.

POINT Selection Notes

- (1) Longer strokes may cause the maximum speed to decrease due to resonance of the ball screw. Be sure to check the maximum speed of the desired stroke in the Actuator Specifications table, which can be found below.
- (2) Both the horizontal and vertical payloads assume operation at an acceleration of 0.3G.
- (3) When the acceleration is increased, the payload will be reduced. Please refer to "Table of Payload by Acceleration" on P.139 for more details.
- (4) Estimated allowable duty varies depending on operating conditions (payload, acceleration/deceleration, etc.). Please refer to P. 149 for more information.

Actuator Specifications								
<b>Lead and Payload</b>								
Model Number	Motor wattage (W)	Lead (mm)	Max. payload	Rated thrust (N)	Stroke (mm)			
RCS4-WSA14R-WA-200-36-①-T2-②-③	200	36	7	—	95	50~800 (50mm increments)		
RCS4-WSA14R-WA-200-24-①-T2-②-③		24	20	2.5	142			
RCS4-WSA14R-WA-200-16-①-T2-②-③		16	45	8	214			
RCS4-WSA14R-WA-200-8-①-T2-②-③		8	65	10	427			
RCS4-WSA14R-WA-200-4-①-T2-②-③		4	75	25	855			
Legend: ① Stroke ② Cable Length ③ Option								
<b>Stroke and Max Speed</b> (Unit: mm/s)								
Stroke	50~450 (50mm increments)	500 (mm)	550 (mm)	600 (mm)	650 (mm)	700 (mm)	750 (mm)	800 (mm)
Lead	1710		1590	1400	1240	1110	990	
24	1440	1420	1220	1060	930	830	740	665
16	960	920	790	690	610	550	490	440
8	480	460	400	350	305	270	240	215
4	240	230	200	170	150	135	120	105

Cable Length	
Type	Cable Code
Standard	<b>P</b> (1m)
	<b>S</b> (3m)
	<b>M</b> (5m)
Specified length (Standard cable)	<b>X06</b> (6m) ~ <b>X10</b> (10m)
	<b>X11</b> (11m) ~ <b>X15</b> (15m)
	<b>X16</b> (16m) ~ <b>X20</b> (20m)
	<b>R01</b> (1m) ~ <b>R03</b> (3m)
Robot cable	<b>R04</b> (4m) ~ <b>R05</b> (5m)
	<b>R06</b> (6m) ~ <b>R10</b> (10m)
	<b>R11</b> (11m) ~ <b>R15</b> (15m)
	<b>R16</b> (16m) ~ <b>R20</b> (20m)

Actuator Specifications	
Item	Description
Drive system	Ball screw ø12mm, rolled C10
Positioning repeatability	±0.01mm
Lost motion	0.1mm or less
Base	Material: Aluminum with white alumite treatment
Allowable static moment	Ma direction 462N·m, Mb direction 462N·m, Mc direction 1170N·m
Allowable dynamic moment (*1)	Ma direction 122N·m, Mb direction 122N·m, Mc direction 308N·m
Ambient operating temp. & humidity	0~40°C, 85% RH or less (Non-condensing)

(\*1) Assumes a standard rated life of 5000km. The service life will vary depending on operation and installation conditions. Please contact IAI for details of the running life.

Options		
Name	Option Code	Reference Page
Brake	<b>B</b>	See P.131
Cable exit direction (Top)	<b>CJT</b>	See P.131
Cable exit direction (Bottom)	<b>CJB</b>	See P.131
Cable exit direction (Outside)	<b>CJO</b>	See P.131
Motor side-mounted to left (standard)	<b>ML</b>	See P.135
Motor side-mounted to right	<b>MR</b>	See P.135
Non-motor end specification	<b>NM</b>	See P.136
Slider roller specification	<b>SR</b>	See P.137
Slider spacer	<b>SS</b>	See P.137

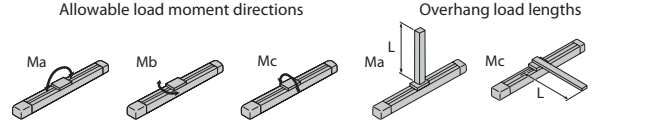

If the load moments in Ma/Mb/Mc direction are within the allowable ranges, there is no overhang load length limit.

Round cable joint connector with screw locking (*1)	<b>EU</b>	See P.131
---	-----------	-----------



## Dimensions

CAD drawings can be downloaded from our website.  
www.robocylinder.de



\*1 When the slider is returning to its home position, please be careful of interference from surrounding objects, as it will travel until it reaches the M.E.  
M.E: Mechanical end S.E: Stroke end

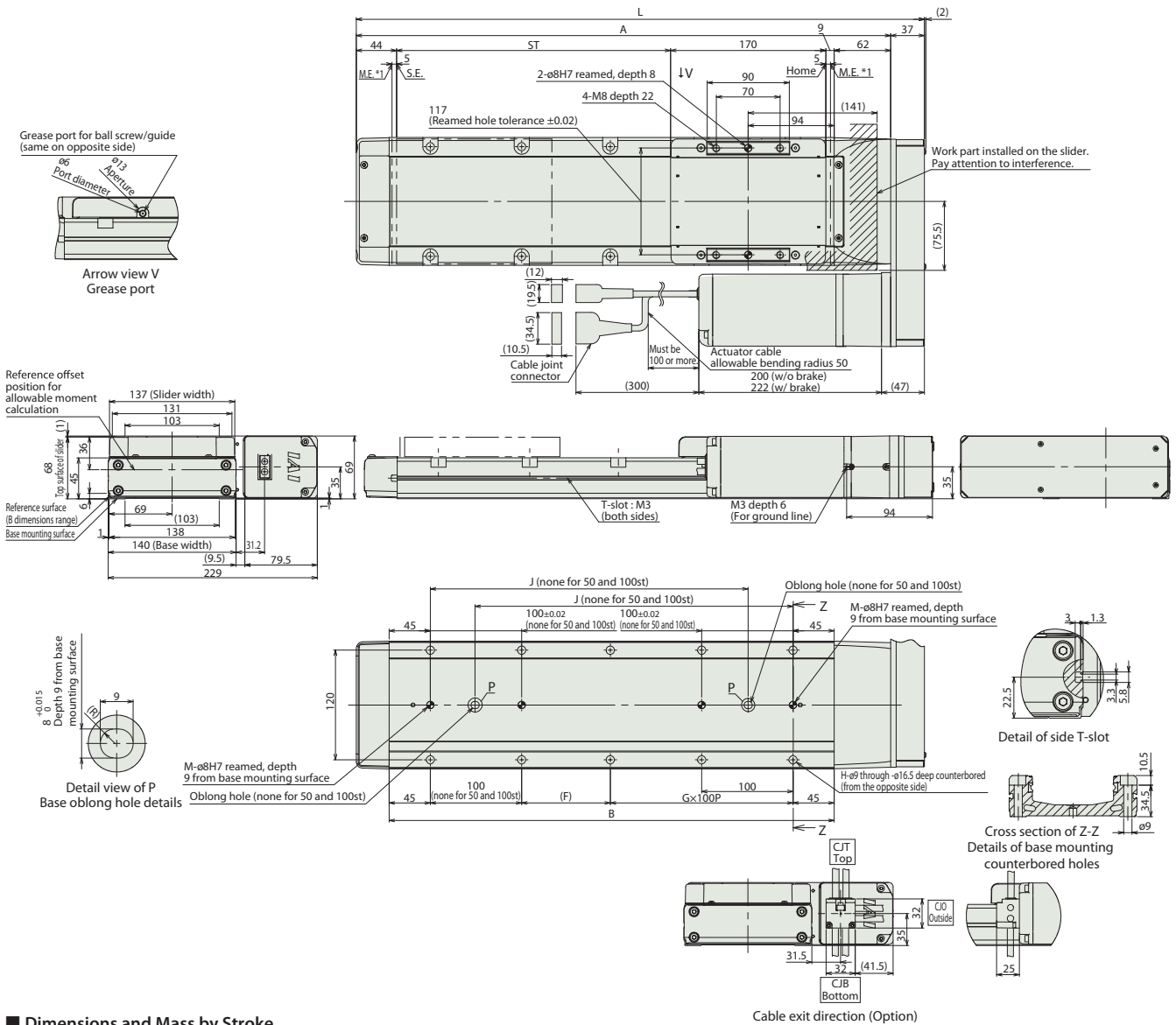

### ■ Dimensions and Mass by Stroke

Stroke	50	100	150	200	250	300	350	400	450	500	550	600	650	700	750	800	
L	372	422	472	522	572	622	672	722	772	822	872	922	972	1022	1072	1122	
A	335	385	435	485	535	585	635	685	735	785	835	885	935	985	1035	1085	
B	237	287	337	387	437	487	537	587	637	687	737	787	837	887	937	987	
F	147	197	247	297	347	397	447	497	547	597	647	697	747	797	847	897	
G	0	0	1	1	2	2	3	3	4	4	5	5	6	6	7	7	
H	4	4	8	8	10	10	12	12	14	14	16	16	18	18	20	20	
J	-	-	198	248	298	348	398	448	498	548	598	648	698	748	798	848	
M	1	1	2	2	2	2	2	2	2	2	2	2	2	2	2	2	
Mass (kg)	W/o brake	7.4	7.9	8.4	8.9	9.4	9.9	10.3	10.8	11.3	11.8	12.3	12.8	13.3	13.8	14.2	14.7
	W/ brake	8.0	8.5	9.0	9.5	10.0	10.5	10.9	11.4	11.9	12.4	12.9	13.4	13.9	14.4	14.8	15.3

### Applicable Controllers

The RCS4 series actuators can be operated by the controllers indicated below. Please select the type depending on your intended use.

Name	External view	Max. number of connectable axes	Input power	Control method				Maximum number of positioning points	Reference page	
				Positioner	Pulse train	Program	Network * Option			
SCON-CB/CGB		1	Single phase 115V/230VAC	●	●	-	DeviceNet CCLink CANopen EtherCAT EtherNet/IP Note: The type of compatible networks will vary depending on the controller. Please refer to the reference page for more information.	512 (768 for network spec.)	Please see the dedicated controller catalog or manual.	
SCON-LC/LCG (*)		1		-	-	●		512 (768 for network spec.)		
SCON-CAL/CGAL		1		●	-	-		512 (768 for network spec.)		
MSCON-C		6		This model is network-compatible only.				256		
SSEL-CS		2		●	-	●		20000		
XSEL-P/Q or XSEL-RA/SA (*)		6 or 8 (Depending on the type)	Single phase 230VAC Three-phase 230VAC	-	-	●	20000 or 55000 (Depending on the type)			

(\*) Coming soon

Foreword  
Slider Type  
Wide Slider Type  
Rod Type  
Radial Cylinder  
Wide Radial Cylinder  
Table Type  
Cleanroom Slider  
Cleanroom Wide Slider  
Options  
Reference Data  
Controller

# RCS4-WSA16R

±10μm  
Standard

Simple  
Dust-  
proof

Battery-  
less  
Absolute

Motor  
Unit  
Coupled

Side-mounted  
Motor

Body Width  
**160\***  
mm

**230v**  
AC Servo  
Motor

<b>Model Specification Items</b>	<b>RCS4</b> — <b>WSA16R</b> — <b>WA</b> — <b>400</b> — <span style="border: 1px solid black; display: inline-block; width: 15px; height: 15px;"></span> — <span style="border: 1px solid black; display: inline-block; width: 15px; height: 15px;"></span> — <b>T2</b> — <span style="border: 1px solid black; display: inline-block; width: 15px; height: 15px;"></span> — <span style="border: 1px solid black; display: inline-block; width: 15px; height: 15px;"></span> * Body width does not include the width of the side-mounted motor.
	Series — Type — Encoder Type — Motor Type — Lead — Stroke — Applicable Controllers — Cable Length — Options
	WA: Battery-less Absolute      400: Servo motor 400W      30:30mm 20:20mm 10:10mm 5: 5mm      50:50mm 1100:1100mm (50mm increments)      T2:SCON SSEL XSEL-P/Q XSEL-RA/SA      N: None P: 1m S: 3m M: 5m      Refer to Options table below.      X□□ : Specified Length      R□□ : Robot Cable

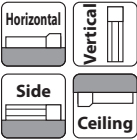

\* Depending on the model, there may be some limitations to using the vertical, side, and ceiling mount positions. Please refer to the Selection Notes on P.138 for more information.

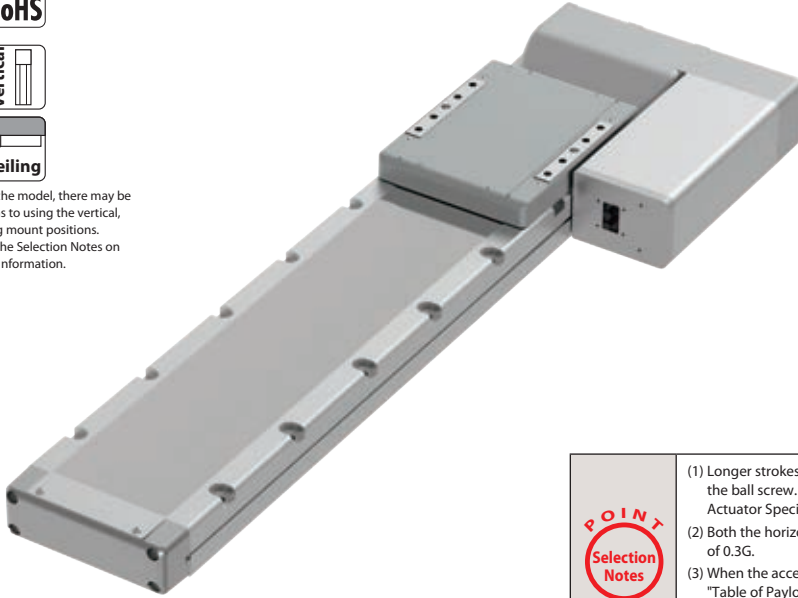

POINT Selection Notes

- (1) Longer strokes may cause the maximum speed to decrease due to resonance of the ball screw. Be sure to check the maximum speed of the desired stroke in the Actuator Specifications table, which can be found below.
- (2) Both the horizontal and vertical payloads assume operation at an acceleration of 0.3G.
- (3) When the acceleration is increased, the payload will be reduced. Please refer to "Table of Payload by Acceleration" on P.139 for more details.
- (4) Estimated allowable duty varies depending on operating conditions (payload, acceleration/deceleration, etc.). Please refer to P. 149 for more information.

### Actuator Specifications

#### Lead and Payload

Model Number	Motor wattage (W)	Lead (mm)	Max. payload		Rated thrust (N)	Stroke (mm)
			Horizontal (kg)	Vertical (kg)		
RCS4-WSA16R-WA-400-30-①-T2-②-③	400	30	30	12	226	50~1100 (50mm increments)
RCS4-WSA16R-WA-400-20-①-T2-②-③		20	60	18	339	
RCS4-WSA16R-WA-400-10-①-T2-②-③		10	80	35	678	
RCS4-WSA16R-WA-400-5-①-T2-②-③		5	100	50	1357	

Legend: ① Stroke ② Cable Length ③ Option

#### Stroke and Max Speed

Stroke / Lead	(Unit: mm/s)											
	50~550 (50mm increments)	600	650	700	750	800	850	900	950	1000	1050	1100
30	1800	1680	1480	1320	1180	1060	960	870	790	730	670	620
20	1200	1120	990	880	780	715	645	590	535	490	450	415
10	600	560	490	440	395	355	320	290	265	240	225	205
5	300	280	240	220	195	175	160	145	130	120	110	100

### Cable Length

Type	Cable Code
Standard	<b>P</b> (1m)
	<b>S</b> (3m)
	<b>M</b> (5m)
Specified length (Standard cable)	<b>X06</b> (6m) ~ <b>X10</b> (10m)
	<b>X11</b> (11m) ~ <b>X15</b> (15m)
	<b>X16</b> (16m) ~ <b>X20</b> (20m)
	<b>R01</b> (1m) ~ <b>R03</b> (3m)
Robot cable	<b>R04</b> (4m) ~ <b>R05</b> (5m)
	<b>R06</b> (6m) ~ <b>R10</b> (10m)
	<b>R11</b> (11m) ~ <b>R15</b> (15m)
	<b>R16</b> (16m) ~ <b>R20</b> (20m)

### Options

Name	Option Code	Reference Page
Brake	<b>B</b>	See P.131
Cable exit direction (Top)	<b>CJT</b>	See P.131
Cable exit direction (Bottom)	<b>CJB</b>	See P.131
Cable exit direction (Outside)	<b>CJO</b>	See P.131
Motor side-mounted to left (standard)	<b>ML</b>	See P.135
Motor side-mounted to right	<b>MR</b>	See P.135
Non-motor end specification	<b>NM</b>	See P.136
Slider roller specification	<b>SR</b>	See P.137

(\*1) EU option will be available soon.

### Actuator Specifications

Item	Description
Drive system	Ball screw ø16mm, rolled C10
Positioning repeatability	±0.01mm
Lost motion	0.1mm or less
Base	Material: Aluminum with white alumite treatment
Allowable static moment	Ma direction 642N-m, Mb direction 642N-m, Mc direction 1610N-m
Allowable dynamic moment (*1)	Ma direction 161N-m, Mb direction 161N-m, Mc direction 404N-m
Ambient operating temp. & humidity	0~40°C, 85% RH or less (Non-condensing)

(\*1) Assumes a standard rated life of 5000km. The service life will vary depending on operation and installation conditions. Please contact IAI for details of the running life.

• Reference for overhang load length: Ma: 650mm or less, Mb, Mc: 650mm or less

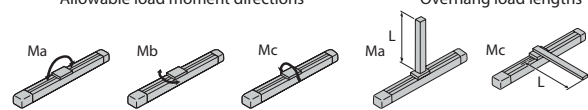

If the load moments in Ma/Mb/Mc direction are within the allowable ranges, there is no overhang load length limit.

Round cable joint connector with screw locking (*1)	<b>EU</b>	See P.131
---	-----------	-----------

## Dimensions

CAD drawings can be downloaded from our website.  
www.robocylinder.de



\*1 When the slider is returning to its home position, please be careful of interference from surrounding objects, as it will travel until it reaches the M.E.  
M.E: Mechanical end S.E: Stroke end

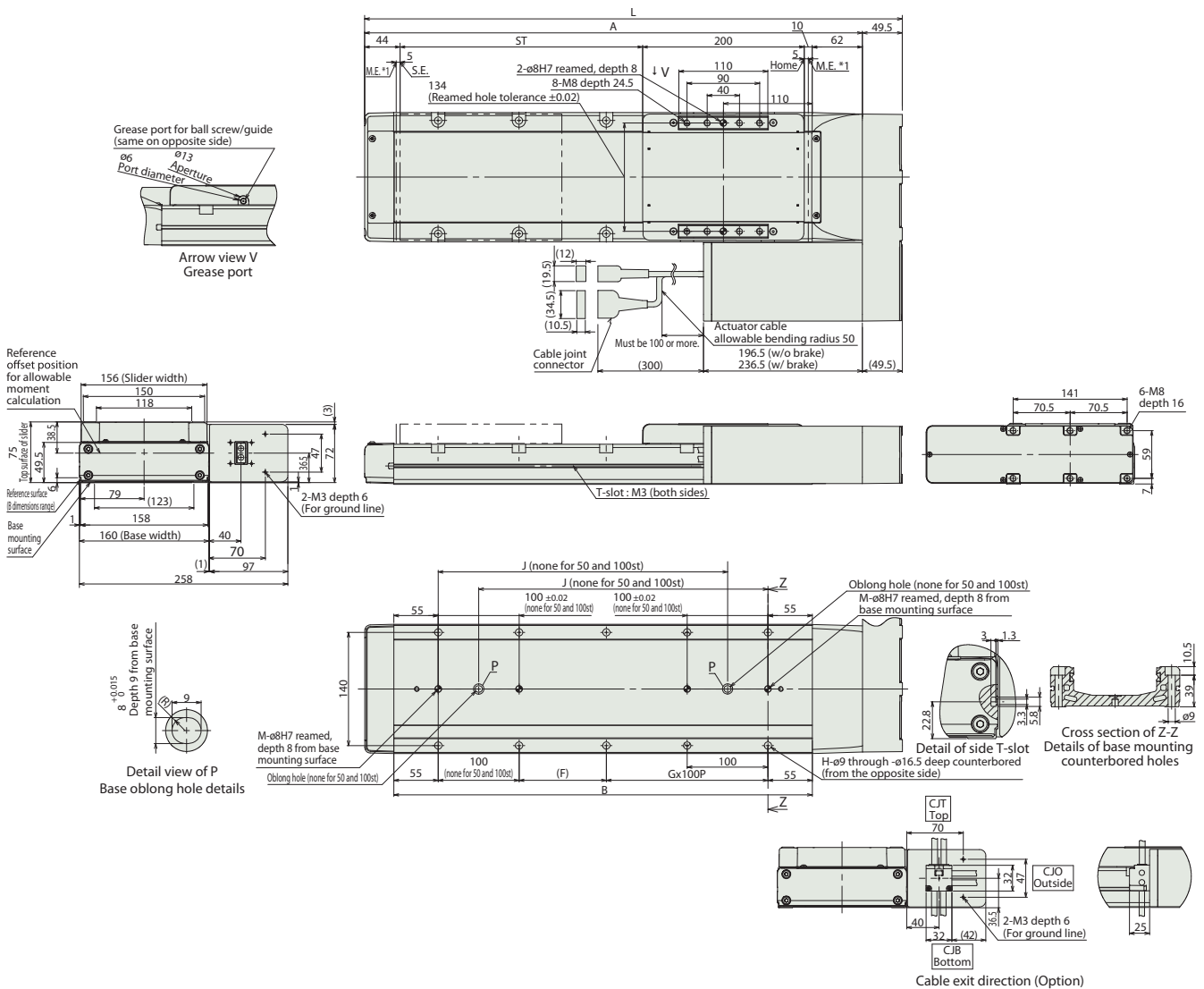

## Dimensions and Mass by Stroke

Stroke	50	100	150	200	250	300	350	400	450	500	550	600	650	700	750	800	850	900	950	1000	1050	1100	
L	415.5	465.5	515.5	565.5	615.5	665.5	715.5	765.5	815.5	865.5	915.5	965.5	1015.5	1065.5	1115.5	1165.5	1215.5	1265.5	1315.5	1365.5	1415.5	1465.5	
A	366	416	466	516	566	616	666	716	766	816	866	916	966	1016	1066	1116	1166	1216	1266	1316	1366	1416	
B	268	318	368	418	468	518	568	618	668	718	768	818	868	918	968	1018	1068	1118	1168	1218	1268	1318	
F	158	208	258	308	358	408	458	508	558	608	658	708	758	808	858	908	958	1008	1058	1108	1158	1208	
G	0	0	1	1	2	2	3	3	4	4	5	5	6	6	7	7	8	8	9	9	10	10	
H	4	4	8	8	10	10	12	12	14	14	16	16	18	18	20	20	22	22	24	24	26	26	
J	-	-	208	258	308	358	408	458	508	558	608	658	708	758	808	858	908	958	1008	1058	1108	1158	
M	1	1	2	2	2	2	2	2	2	2	2	2	2	2	2	2	2	2	2	2	2	2	
Mass (kg)	W/o brake	10.6	11.2	11.8	12.4	13.0	13.6	14.2	14.9	15.5	16.1	16.7	17.3	17.9	18.5	19.1	19.8	20.4	21.0	21.6	22.2	22.8	23.4
	W/brake	11.2	11.8	12.4	13.0	13.6	14.2	14.8	15.5	16.1	16.7	17.3	17.9	18.5	19.1	19.7	20.4	21.0	21.6	22.2	22.8	23.4	24.0

## Applicable Controllers

The RCS4 series actuators can be operated by the controllers indicated below. Please select the type depending on your intended use.

Name	External view	Max. number of connectable axes	Input power	Control method				Maximum number of positioning points	Reference page
				Positioner	Pulse train	Program	Network * Option		
SCON-CB/CGB		1	Single phase 230VAC	●	●	-	DeviceNet CC-Link CompoNet EtherCAT EtherNet/IP	512 (768 for network spec.)	Please see P.151
SCON-LC/LCG (*)		1		-	-	●			
SSEL-CS		2	Single phase 115V/230VAC	●	-	●	Note: The type of compatible networks will vary depending on the controller. Please refer to the reference page for more information.	20000	Please see the dedicated controller catalog or manual.
XSEL-P/Q or XSEL-RA/SA (*)		6 or 8 (Depending on the type)	Single phase 230VAC Three-phase 230VAC	-	-	●		20000 or 55000 (Depending on the type)	

(\*) Coming soon

Foreword  
Slider Type  
Wide Slider Type  
Rod Type  
Radial Cylinder  
Wide Radial Cylinder  
Table Type  
Cleanroom Slider  
Cleanroom Wide Slider  
Options  
Reference Data  
Controller

# RCS4-RA4C

Battery-less Absolute
Motor Unit Coupled
Straight Motor
Body Width 40 mm
230v AC Servo Motor

Model Specification Items	<b>RCS4</b> — <b>RA4C</b> — <b>WA</b> — <b>60</b> — [ ] — [ ] — [ ] — <b>T2</b> — [ ] — [ ]
	Series — Type — Encoder Type — Motor Type — Lead — Stroke — Applicable Controllers — Cable Length — Options
	WA: Battery-less Absolute 60: Servo motor 60W 16: 16mm 10: 10mm 5: 5mm 2.5: 2.5mm 50: 50mm 200: 200mm (50mm increments) T2: SCON, MSCON, SSEL, XSEL-P/Q, XSEL-RA/S N: None, P: 1m, S: 3m, M: 5m X□□: Specified Length R□□: Robot Cable

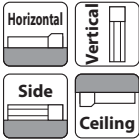

\* Depending on the model, there may be some limitations to using the vertical, side, and ceiling mount positions. Please refer to the Selection Notes on P.138 for more information.

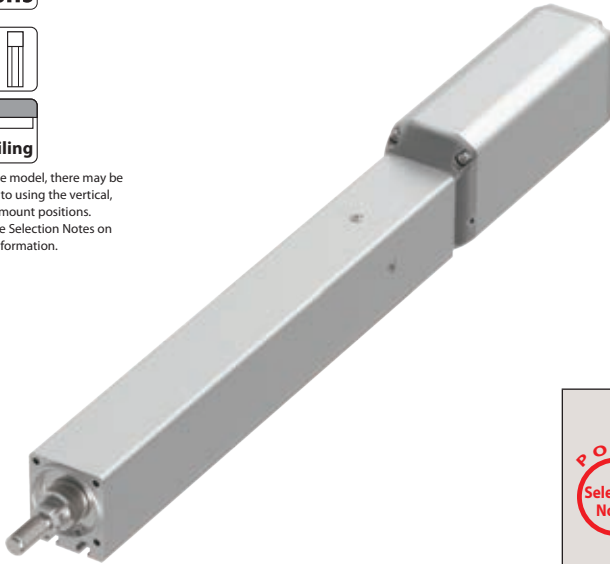

**POINT Selection Notes**

- Both the horizontal and vertical payloads assume operation at an acceleration of 0.3G.
- When the acceleration is increased, the payload will be reduced. Please refer to "Table of Payload by Acceleration" on P.139 for more details.
- Estimated allowable duty varies depending on operating conditions (payload, acceleration/deceleration, etc.). Please refer to P. 149 for more information.
- The value of the horizontal payload assumes that there is an external guide. Please be aware that the anti-rotation stopper can be damaged when an external force is applied to the rod from any direction other than the moving direction.

## Actuator Specifications

### Lead and Payload

Model Number	Motor wattage (W)	Lead (mm)	Max. payload		Rated thrust (N)	Stroke (mm)
			Horizontal (kg)	Vertical (kg)		
RCS4-RA4C-WA-60-16-①-T2-②-③	60	16	8	2	53	50~200 (50mm increments)
RCS4-RA4C-WA-60-10-①-T2-②-③		10	18	4	85	
RCS4-RA4C-WA-60-5-①-T2-②-③		5	30	6	170	
RCS4-RA4C-WA-60-2.5-①-T2-②-③		2.5	40	10	340	

Legend: ① Stroke ② Cable Length ③ Option

### Stroke and Max Speed (Unit: mm/s)

Lead	Stroke	
	50~200 (50mm increments)	
16	800	
10	500	
5	250	
2.5	125	

## Cable Length

Type	Cable Code
Standard	P (1m)
	S (3m)
	M (5m)
Specified length (Standard cable)	X06 (6m) ~ X10 (10m)
	X11 (11m) ~ X15 (15m)
	X16 (16m) ~ X20 (20m)
	R01 (1m) ~ R03 (3m)
Robot cable	R04 (4m) ~ R05 (5m)
	R06 (6m) ~ R10 (10m)
	R11 (11m) ~ R15 (15m)
	R16 (16m) ~ R20 (20m)

## Actuator Specifications

Item	Description
Drive system	Ball screw ø8mm, rolled C10
Positioning repeatability	±0.01mm
Lost motion	0.1mm or less
Rod	ø20mm Material: Aluminum with hard alumite treatment
Static allowable torque on rod tip	To: 1.0N·m
Max. angular displacement on rod tip (*1)	θ: ±1.0 deg.
Ambient operating temp. & humidity	0~40°C, 85% RH or less (Non-condensing)

(\*1) This is the displacement angle of the rod tip (initial reference value) when the rod is fully retracted and the static allowable torque is applied at the rod tip.

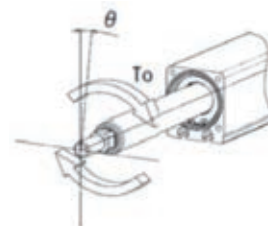

## Options

Name	Option Code	Reference Page
Brake	B	See P.131
Cable exit direction (Top)	CJT	See P.131
Cable exit direction (Right)	CJR	See P.131
Cable exit direction (Left)	CJL	See P.131
Cable exit direction (Bottom)	CJB	See P.131
Flange	FL	See P.132
Foot bracket	FT	See P.133
Tip adapter (Internal thread)	NFA	See P.135
Non-motor end specification	NM	See P.136
T-slot nut bar	NTB	See P.136

Round cable joint connector with screw locking (*1)	EU	See P.131
---	----	-----------

(\*1) EU option will be available soon.



# RCS4-RA6C

Battery-less Absolute
Motor Unit Coupled
Straight Motor
Body Width 60 mm
230v AC Servo Motor

Model Specification Items	<b>RCS4</b> — <b>RA6C</b> — <b>WA</b> — <b>100</b> — [ ] — [ ] — [ ] — [ ]
	Series — Type — Encoder Type — Motor Type — Lead — Stroke — Applicable Controllers — Cable Length — Options
	WA: Battery-less Absolute      100: Servo motor 100W      20:20mm 12:12mm 6: 6mm 3: 3mm      50:50mm 300:300mm (50mm increments)      T2:SCON MSCON SSEL XSEL-P/Q XSEL-RA/SA      N : None P : 1m S : 3m M : 5m X□□ : Specified Length R□□ : Robot Cable      Refer to Options table below.

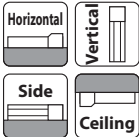

\* Depending on the model, there may be some limitations to using the vertical, side, and ceiling mount positions. Please refer to the Selection Notes on P.138 for more information.

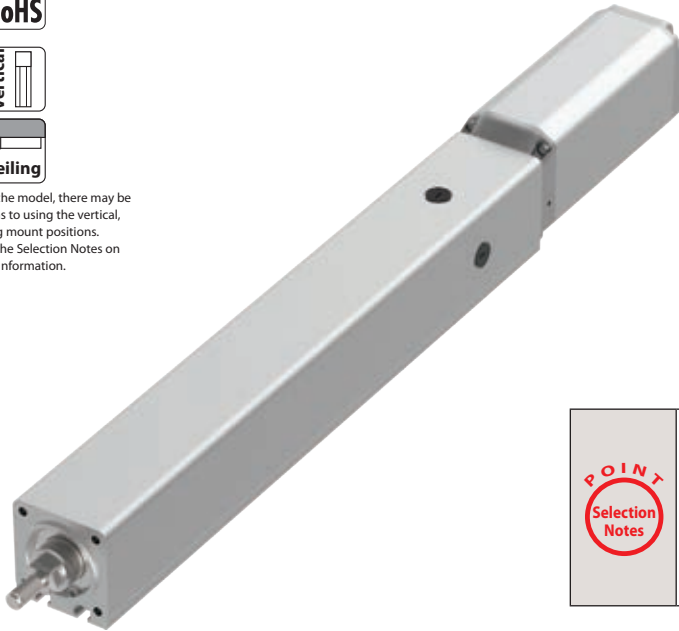

- (1) Both the horizontal and vertical payloads assume operation at an acceleration of 0.3G.
- (2) When the acceleration is increased, the payload will be reduced. Please refer to "Table of Payload by Acceleration" on P.139 for more details.
- (3) Estimated allowable duty varies depending on operating conditions (payload, acceleration/deceleration, etc.). Please refer to P. 149 for more information.
- (4) The value of the horizontal payload assumes that there is an external guide. Please be aware that the anti-rotation stopper can be damaged when an external force is applied to the rod from any direction other than the moving direction.

## Actuator Specifications

### Lead and Payload

Model Number	Motor wattage (W)	Lead (mm)	Max. payload		Rated thrust (N)	Stroke (mm)
			Horizontal (kg)	Vertical (kg)		
RCS4-RA6C-WA-100-20-①-T2-②-③	100	20	15	4	85	50~300 (50mm increments)
RCS4-RA6C-WA-100-12-①-T2-②-③		12	25	10	142	
RCS4-RA6C-WA-100-6-①-T2-②-③		6	50	20	283	
RCS4-RA6C-WA-100-3-①-T2-②-③		3	60	20	566	

Legend: ① Stroke ② Cable Length ③ Option

### Stroke and Max Speed (Unit: mm/s)

Lead	Stroke	
	50~300 (50mm increments)	
20	1000	
12	600	
6	300	
3	150	

## Cable Length

Type	Cable Code
Standard	P (1m)
	S (3m)
	M (5m)
Specified length (Standard cable)	X06 (6m) ~ X10 (10m)
	X11 (11m) ~ X15 (15m)
	X16 (16m) ~ X20 (20m)
	R01 (1m) ~ R03 (3m)
Robot cable	R04 (4m) ~ R05 (5m)
	R06 (6m) ~ R10 (10m)
	R11 (11m) ~ R15 (15m)
	R16 (16m) ~ R20 (20m)

## Actuator Specifications

Item	Description
Drive system	Ball screw ø10mm, rolled C10
Positioning repeatability	±0.01mm
Lost motion	0.1mm or less
Rod	ø25mm Material: Aluminum with hard alumite treatment
Static allowable torque on rod tip	To: 1.5N·m
Max. angular displacement on rod tip (*1)	θ: ±1.0 deg.
Ambient operating temp. & humidity	0~40°C, 85% RH or less (Non-condensing)

(\*1) This is the displacement angle of the rod tip (initial reference value) when the rod is fully retracted and the static allowable torque is applied at the rod tip.

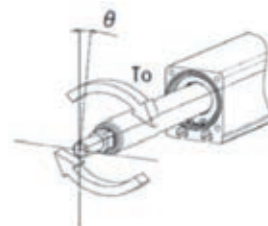

## Options

Name	Option Code	Reference Page
Brake	B	See P.131
Cable exit direction (Top)	CJT	See P.131
Cable exit direction (Right)	CJR	See P.131
Cable exit direction (Left)	CJL	See P.131
Cable exit direction (Bottom)	CJB	See P.131
Flange	FL	See P.132
Foot bracket	FT	See P.133
Tip adapter (Internal thread)	NFA	See P.135
Non-motor end specification	NM	See P.136
T-slot nut bar	NTB	See P.136

Round cable joint connector with screw locking (*1)	EU	See P.131
---	----	-----------

(\*1) EU option will be available soon.

## Dimensions

CAD drawings can be downloaded from our website.  
[www.robocylinder.de](http://www.robocylinder.de)



- \*1 When the rod is returning to its home position, please be careful of interference from surrounding objects, as it will travel until it reaches the M.E.  
 M.E: Mechanical end S.E: Stroke end
- \*2 The direction of width across flat varies depending on the product. Those flats cannot be used for vertical or horizontal reference plane.

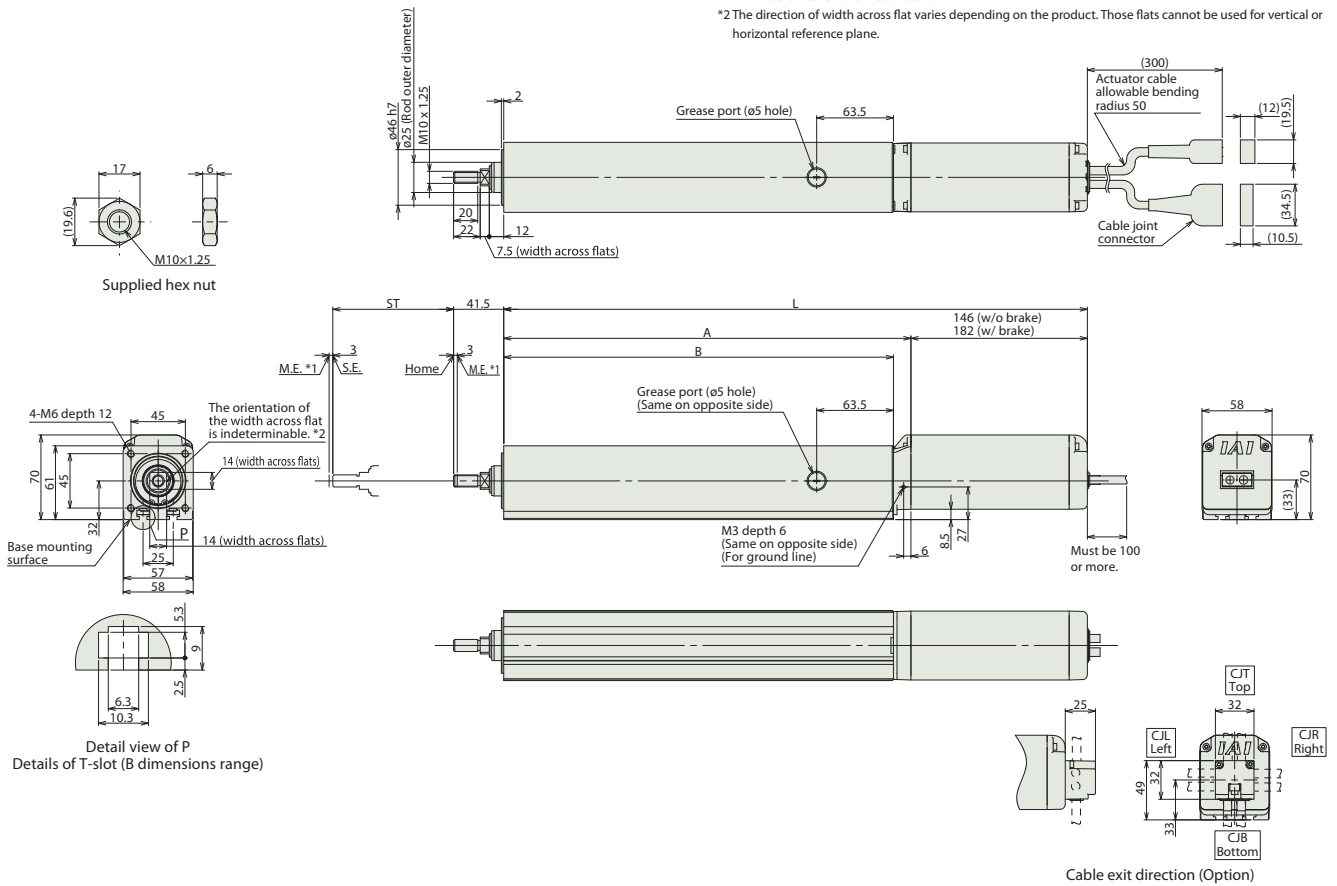

### Dimensions and Mass by Stroke

L	Stroke	50	100	150	200	250	300
	W/o brake	333	383	433	483	533	583
	W/ brake	369	419	469	519	569	619
	A	187	237	287	337	387	437
	B	172.5	222.5	272.5	322.5	372.5	422.5
Mass (kg)	W/o brake	2.6	3.0	3.4	3.8	4.1	4.5
	W/ brake	2.9	3.3	3.7	4.1	4.4	4.8

### Applicable Controllers

The RCS4 series actuators can be operated by the controllers indicated below. Please select the type depending on your intended use.

Name	External view	Max. number of connectable axes	Input power	Control method				Maximum number of positioning points	Reference page	
				Positioner	Pulse train	Program	Network * Option			
SCON-CB/CGB		1	Single phase 115V/230VAC	●	●	—	DeviceNet CC-Link CANopen EtherCAT EtherNet/IP Note: The type of compatible networks will vary depending on the controller. Please refer to the reference page for more information.	512 (768 for network spec.)	Please see the dedicated controller catalog or manual.	
SCON-LC/LCG (*)		1		—	—	●		512 (768 for network spec.)		
SCON-CAL/CGAL		1		●	—	—		512 (768 for network spec.)		
MSCON-C		6		This model is network-compatible only.				256		
SSEL-CS		2		●	—	●		20000		
XSEL-P/Q or XSEL-RA/SA (*)		6 or 8 (Depending on the type)	Single phase 230VAC Three-phase 230VAC	—	—	●	20000 or 55000 (Depending on the type)			

(\*) Coming soon

Foreword  
 Slider Type  
 Wide Slider Type  
 Rod Type  
 Radial Cylinder  
 Wide Radial Cylinder  
 Table Type  
 Cleanroom Slider  
 Cleanroom Wide Slider  
 Options  
 Reference Data  
 Controller

# RCS4-RA7C

Battery-less Absolute
Motor Unit Coupled
Straight Motor
Body Width 70mm
230v AC Servo Motor

Model Specification Items	<b>RCS4</b>	<b>RA7C</b>	<b>WA</b>	<b>200</b>			<b>T2</b>		
	Series	Type	Encoder Type	Motor Type	Lead	Stroke	Applicable Controllers	Cable Length	Options
	WA: Battery-less Absolute	200: Servo motor 200W	24:24mm 16:16mm 8: 8mm 4: 4mm	50:50mm 300:300mm (50mm increments)	T2:SCON MSCON SSEL XSEL-P/Q XSEL-RA/SA	N : None P : 1m S : 3m M : 5m X□□ : Specified Length R□□ : Robot Cable	Refer to Options table below.		

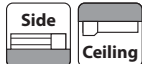

\* Depending on the model, there may be some limitations to using the vertical, side, and ceiling mount positions. Please refer to the Selection Notes on P.138 for more information.



**POINT Selection Notes**

- (1) Both the horizontal and vertical payloads assume operation at an acceleration of 0.3G.
- (2) When the acceleration is increased, the payload will be reduced. Please refer to "Table of Payload by Acceleration" on P.139 for more details.
- (3) Estimated allowable duty varies depending on operating conditions (payload, acceleration/deceleration, etc.). Please refer to P. 149 for more information.
- (4) The value of the horizontal payload assumes that there is an external guide. Please be aware that the anti-rotation stopper can be damaged when an external force is applied to the rod from any direction other than the moving direction.

## Actuator Specifications

### Lead and Payload

Model Number	Motor wattage (W)	Lead (mm)	Max. payload		Rated thrust (N)	Stroke (mm)
			Horizontal (kg)	Vertical (kg)		
RCS4-RA7C-WA-200-24-①-T2-②-③	200	24	20	6	142	50~300 (50mm increments)
RCS4-RA7C-WA-200-16-①-T2-②-③		16	45	12	214	
RCS4-RA7C-WA-200-8-①-T2-②-③		8	60	25	427	
RCS4-RA7C-WA-200-4-①-T2-②-③		4	80	35	855	

Legend: ① Stroke ② Cable Length ③ Option

### Stroke and Max Speed (Unit: mm/s)

Lead	Stroke	50~300 (50mm increments)
	24	
16		800
8		400
4		200

## Cable Length

Type	Cable Code
Standard	<b>P</b> (1m)
	<b>S</b> (3m)
	<b>M</b> (5m)
Specified length (Standard cable)	<b>X06</b> (6m) ~ <b>X10</b> (10m)
	<b>X11</b> (11m) ~ <b>X15</b> (15m)
	<b>X16</b> (16m) ~ <b>X20</b> (20m)
Robot cable	<b>R01</b> (1m) ~ <b>R03</b> (3m)
	<b>R04</b> (4m) ~ <b>R05</b> (5m)
	<b>R06</b> (6m) ~ <b>R10</b> (10m)
	<b>R11</b> (11m) ~ <b>R15</b> (15m)
	<b>R16</b> (16m) ~ <b>R20</b> (20m)

## Actuator Specifications

Item	Description
Drive system	Ball screw ø12mm, rolled C10
Positioning repeatability	±0.01mm
Lost motion	0.1mm or less
Rod	ø30mm Material: Aluminum with hard alumite treatment
Static allowable torque on rod tip	To: 2.5N·m
Max. angular displacement on rod tip (*1)	θ: ±0.8 deg.
Ambient operating temp. & humidity	0~40°C, 85% RH or less (Non-condensing)

(\*1) This is the displacement angle of the rod tip (initial reference value) when the rod is fully retracted and the static allowable torque is applied at the rod tip.

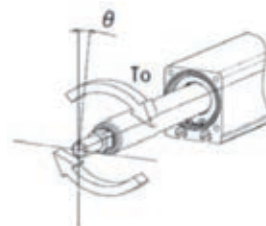

## Options

Name	Option Code	Reference Page
Brake	<b>B</b>	See P.131
Cable exit direction (Top)	<b>CJT</b>	See P.131
Cable exit direction (Right)	<b>CJR</b>	See P.131
Cable exit direction (Left)	<b>CJL</b>	See P.131
Cable exit direction (Bottom)	<b>CJB</b>	See P.131
Flange	<b>FL</b>	See P.132
Foot bracket	<b>FT</b>	See P.133
Tip adapter (Internal thread)	<b>NFA</b>	See P.135
Non-motor end specification	<b>NM</b>	See P.136
T-slot nut bar	<b>NTB</b>	See P.136

Round cable joint connector with screw locking (*1)	<b>EU</b>	See P.131
---	-----------	-----------

(\*1) EU option will be available soon.



## Dimensions

CAD drawings can be downloaded from our website.  
[www.robocylinder.de](http://www.robocylinder.de)



- \*1 When the rod is returning to its home position, please be careful of interference from surrounding objects, as it will travel until it reaches the M.E.  
 M.E: Mechanical end S.E: Stroke end
- \*2 The direction of width across flat varies depending on the product. Those flats cannot be used for vertical or horizontal reference plane.

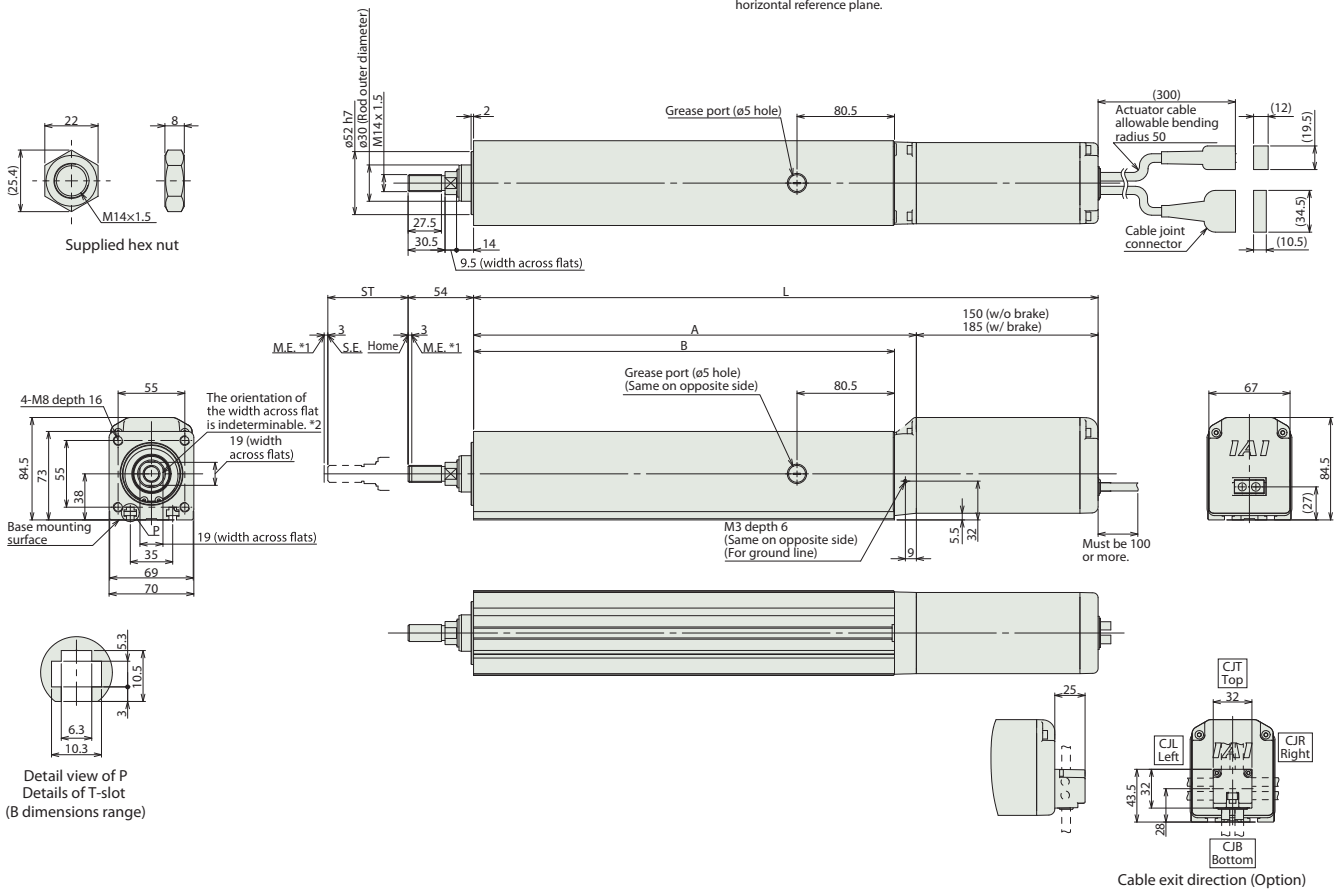

## Dimensions and Mass by Stroke

L	Stroke	50	100	150	200	250	300
	W/o brake	365.5	415.5	465.5	515.5	565.5	615.5
	W/ brake	400.5	450.5	500.5	550.5	600.5	650.5
	A	215.5	265.5	315.5	365.5	415.5	465.5
	B	197.5	247.5	297.5	347.5	397.5	447.5
Mass (kg)	W/o brake	4.6	5.2	5.7	6.3	6.9	7.5
	W/ brake	5.1	5.7	6.2	6.8	7.4	8.0

## Applicable Controllers

The RCS4 series actuators can be operated by the controllers indicated below. Please select the type depending on your intended use.

Name	External view	Max. number of connectable axes	Input power	Control method				Maximum number of positioning points	Reference page	
				Positioner	Pulse train	Program	Network * Option			
SCON-CB/CGB		1	Single phase 115V/230VAC	●	●	—	DeviceNet CC-Link CANopen EtherCAT EtherNet/IP Note: The type of compatible networks will vary depending on the controller. Please refer to the reference page for more information.	512 (768 for network spec.)	Please see the dedicated controller catalog or manual.	
SCON-LC/LCG (*)		1		—	—	●		512 (768 for network spec.)		
SCON-CAL/CGAL		1		●	—	—		512 (768 for network spec.)		
MSCON-C		6		This model is network-compatible only.				256		
SSEL-CS		2		●	—	●		20000		
XSEL-P/Q or XSEL-RA/SA (*)		6 or 8 (Depending on the type)	Single phase 230VAC Three-phase 230VAC	—	—	●	20000 or 55000 (Depending on the type)			

(\*) Coming soon

Foreword  
 Slider Type  
 Wide Slider Type  
 Rod Type  
 Radial Cylinder  
 Wide Radial Cylinder  
 Table Type  
 Cleanroom Slider  
 Cleanroom Wide Slider  
 Options  
 Reference Data  
 Controller

# RCS4-RA8C

Battery-less Absolute
Motor Unit Coupled
Straight Motor
Body Width 90 mm
230v AC Servo Motor

Model Specification Items	<b>RCS4</b> — <b>RA8C</b> — <b>WA</b> — <b>400</b> — <input type="checkbox"/> — <input type="checkbox"/> — <input type="checkbox"/> — <input type="checkbox"/> — <input type="checkbox"/>	<b>T2</b> — <input type="checkbox"/> — <input type="checkbox"/>					
	Series — Type — Encoder Type — Motor Type — Lead — Stroke — Applicable Controllers — Cable Length — Options						
	WA: Battery-less Absolute	400: Servo motor 400W	20:20mm 10:10mm 5: 5mm	50:50mm 300:300mm (50mm increments)	T2:SCON SSEL XSEL-P/Q XSEL-RA/SA	N : None P : 1m S : 3m M : 5m	Refer to Options table below.
	X□□ : Specified Length R□□ : Robot Cable						

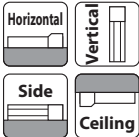

\* Depending on the model, there may be some limitations to using the vertical, side, and ceiling mount positions. Please refer to the Selection Notes on P.138 for more information.



**POINT Selection Notes**

- Both the horizontal and vertical payloads assume operation at an acceleration of 0.3G. (0.2G for vertical lead 5).
- When the acceleration is increased, the payload will be reduced. Please refer to "Table of Payload by Acceleration" on P.139 for more details.
- Estimated allowable duty varies depending on operating conditions (payload, acceleration/deceleration, etc.). Please refer to P. 149 for more information.
- The value of the horizontal payload assumes that there is an external guide. Please be aware that the anti-rotation stopper can be damaged when an external force is applied to the rod from any direction other than the moving direction.

## Actuator Specifications

### Lead and Payload

Model Number	Motor wattage (W)	Lead (mm)	Max. payload		Rated thrust (N)	Stroke (mm)
			Horizontal (kg)	Vertical (kg)		
RCS4-RA8C-WA-400-20-①-T2-②-③	400	20	60	20	339	50~300 (50mm increments)
RCS4-RA8C-WA-400-10-①-T2-②-③		10	80	40	678	
RCS4-RA8C-WA-400-5-①-T2-②-③		5	100	72	1357	

Legend: ① Stroke ② Cable Length ③ Option

### Stroke and Max Speed (Unit: mm/s)

Lead	Stroke	50~300 (50mm increments)
	20	
10		500
5		250

## Cable Length

Type	Cable Code
Standard	P (1m)
	S (3m)
	M (5m)
Specified length (Standard cable)	X06 (6m) ~ X10 (10m)
	X11 (11m) ~ X15 (15m)
	X16 (16m) ~ X20 (20m)
	R01 (1m) ~ R03 (3m)
	R04 (4m) ~ R05 (5m)
Robot cable	R06 (6m) ~ R10 (10m)
	R11 (11m) ~ R15 (15m)
	R16 (16m) ~ R20 (20m)

## Actuator Specifications

Item	Description
Drive system	Ball screw ø16mm, rolled C10
Positioning repeatability	±0.01mm
Lost motion	0.1mm or less
Rod	ø40mm Material: Aluminum with hard alumite treatment
Static allowable torque on rod tip	To: 5.0N·m
Max. angular displacement on rod tip (*1)	θ: ±0.8 deg.
Ambient operating temp. & humidity	0~40°C, 85% RH or less (Non-condensing)

(\*1) This is the displacement angle of the rod tip (initial reference value) when the rod is fully retracted and the static allowable torque is applied at the rod tip.

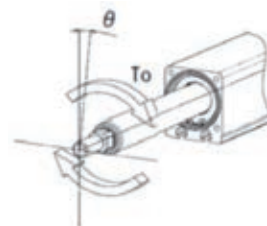

## Options

Name	Option Code	Reference Page
Brake	B	See P.131
Cable exit direction (Top)	CJT	See P.131
Cable exit direction (Right)	CJR	See P.131
Cable exit direction (Left)	CJL	See P.131
Cable exit direction (Bottom)	CJB	See P.131
Flange	FL	See P.132
Foot bracket	FT	See P.133
Tip adapter (Internal thread)	NFA	See P.135
Non-motor end specification	NM	See P.136
T-slot nut bar	NTB	See P.136

Round cable joint connector with screw locking (*1)	EU	See P.131
---	----	-----------

(\*1) EU option will be available soon.

## Dimensions

CAD drawings can be downloaded from our website.  
www.robocylinder.de



- \*1 When the rod is returning to its home position, please be careful of interference from surrounding objects, as it will travel until it reaches the M.E.  
M.E: Mechanical end S.E: Stroke end
- \*2 The direction of width across flat varies depending on the product. Those flats cannot be used for vertical or horizontal reference plane.

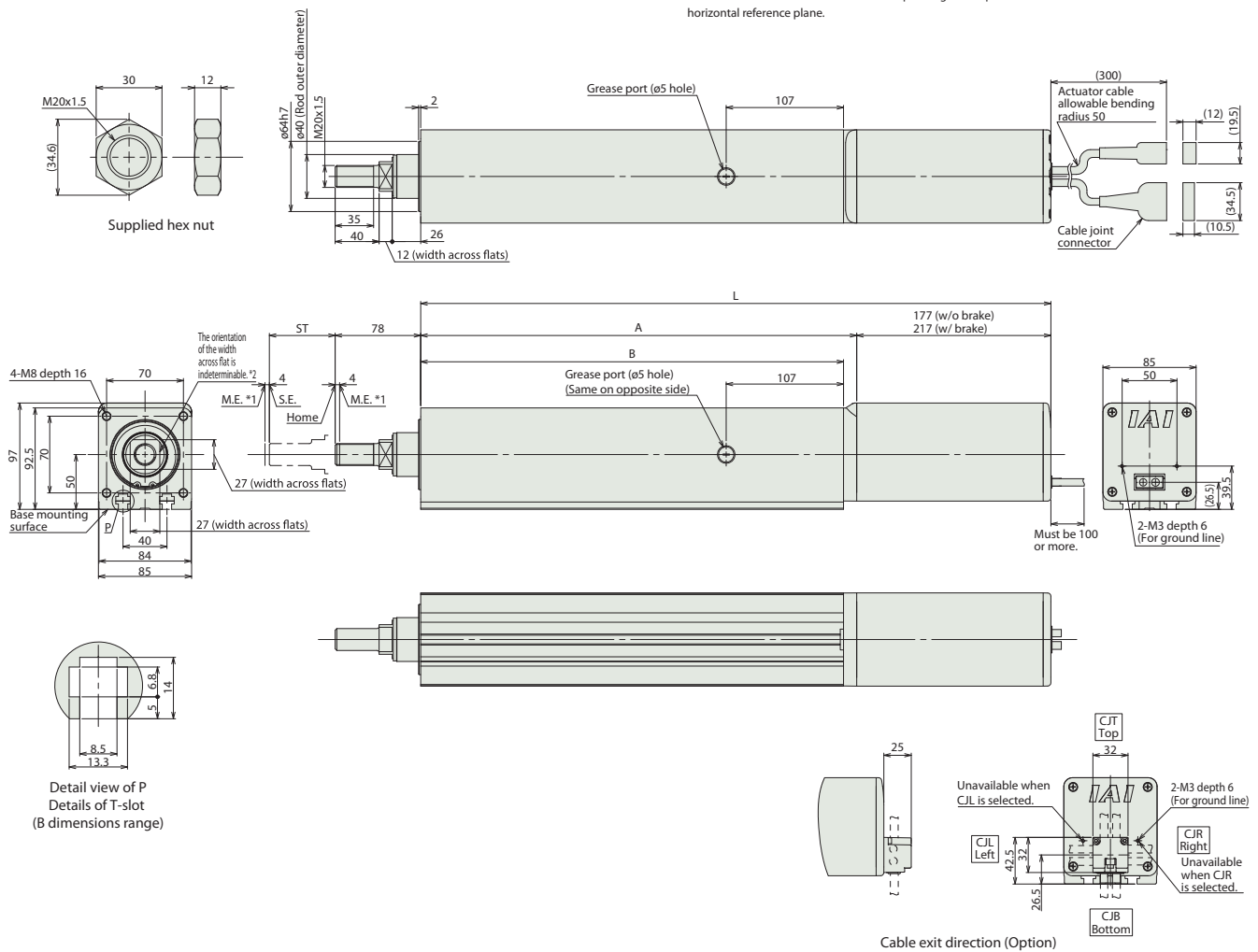

### ■ Dimensions and Mass by Stroke

L	Stroke	50	100	150	200	250	300
	W/o brake	424.5	474.5	524.5	574.5	624.5	674.5
W/ brake	464.5	514.5	564.5	614.5	664.5	714.5	
A	247.5	297.5	347.5	397.5	447.5	497.5	
B	235.5	285.5	335.5	385.5	435.5	485.5	
Mass (kg)	W/o brake	8.3	9.2	10.0	10.8	11.7	12.5
	W/ brake	8.9	9.8	10.6	11.4	12.3	13.1

### ■ Applicable Controllers

The RCS4 series actuators can be operated by the controllers indicated below. Please select the type depending on your intended use.

Name	External view	Max. number of connectable axes	Input power	Control method				Maximum number of positioning points	Reference page
				Positioner	Pulse train	Program	Network * Option		
SCON-CB/CGB		1	Single phase 230VAC	●	●	—	DeviceNet CC-Link CompoNet EtherCAT EtherNet/IP	512 (768 for network spec.)	Please see P.151
SCON-LC/LCG (*)		1		—	—	●			
SSEL-CS		2	Single phase 115V/230VAC	●	—	●	Note: The type of compatible networks will vary depending on the controller. Please refer to the reference page for more information.	20000	Please see the dedicated controller catalog or manual.
XSEL-P/Q or XSEL-RA/SA (*)		6 or 8 (Depending on the type)	Single phase 230VAC Three-phase 230VAC	—	—	●		20000 or 55000 (Depending on the type)	

(\*) Coming soon

Foreword  
Slider Type  
Wide Slider Type  
Rod Type  
Radial Cylinder  
Wide Radial Cylinder  
Table Type  
Cleanroom Slider  
Cleanroom Wide Slider  
Options  
Reference Data  
Controller

# RCS4-RA4R

Battery-less Absolute
Motor Unit Coupled
Side-mounted Motor
Body Width 40\* mm
230v AC Servo Motor

Model Specification Items	<b>RCS4</b> — <b>RA4R</b> — <b>WA</b> — <b>60</b> — [ ] — [ ] — [ ] — <b>T2</b> — [ ] — [ ]	* Body width does not include the width of the side-mounted motor.
	Series — Type — Encoder Type — Motor Type — Lead — Stroke — Applicable Controllers — Cable Length — Options WA: Battery-less Absolute    60: Servo motor 60W    16: 16mm 10: 10mm 5: 5mm 2.5: 2.5mm    50: 50mm 200: 200mm (50mm increments)    T2: SCON MSCON SSEL XSEL-P/Q XSEL-RA/SA    N: None P: 1m S: 3m M: 5m    Refer to Options table below.    X□□: Specified Length R□□: Robot Cable	

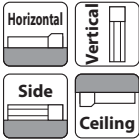

\* Depending on the model, there may be some limitations to using the vertical, side, and ceiling mount positions. Please refer to the Selection Notes on P.138 for more information.

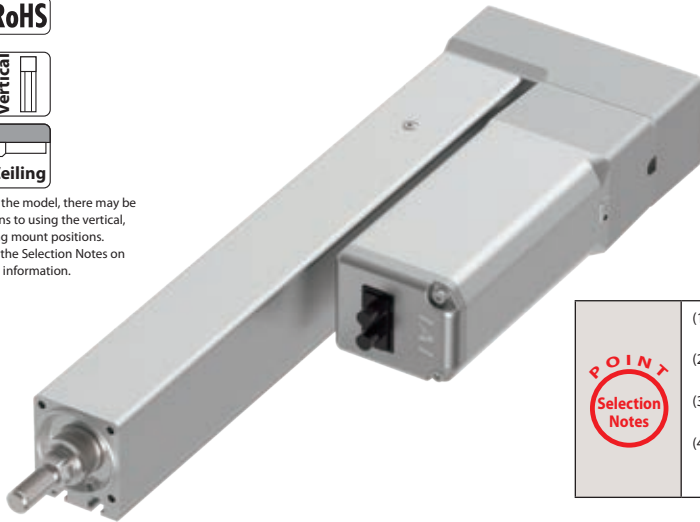

- POINT Selection Notes**
- Both the horizontal and vertical payloads assume operation at an acceleration of 0.3G.
  - When the acceleration is increased, the payload will be reduced. Please refer to "Table of Payload by Acceleration" on P.139 for more details.
  - Estimated allowable duty varies depending on operating conditions (payload, acceleration/deceleration, etc.). Please refer to P. 149 for more information.
  - The value of the horizontal payload assumes that there is an external guide. Please be aware that the anti-rotation stopper can be damaged when an external force is applied to the rod from any direction other than the moving direction.

## Actuator Specifications

### Lead and Payload

Model Number	Motor wattage (W)	Lead (mm)	Max. payload		Rated thrust (N)	Stroke (mm)
			Horizontal (kg)	Vertical (kg)		
RCS4-RA4R-WA-60-16-①-T2-②-③	60	16	8	2	53	50~200 (50mm increments)
RCS4-RA4R-WA-60-10-①-T2-②-③		10	18	4	85	
RCS4-RA4R-WA-60-5-①-T2-②-③		5	30	6	170	
RCS4-RA4R-WA60-2.5-①-T2-②-③		2.5	40	10	340	

Legend: ① Stroke ② Cable Length ③ Option

### Stroke and Max Speed (Unit: mm/s)

Lead	Stroke	
	50~200 (50mm increments)	50~200 (50mm increments)
16	800	
10	500	
5	250	
2.5	125	

### Cable Length

Type	Cable Code
Standard	P (1m)
	S (3m)
	M (5m)
Specified length (Standard cable)	X06 (6m) ~ X10 (10m)
	X11 (11m) ~ X15 (15m)
	X16 (16m) ~ X20 (20m)
	R01 (1m) ~ R03 (3m)
	R04 (4m) ~ R05 (5m)
Robot cable	R06 (6m) ~ R10 (10m)
	R11 (11m) ~ R15 (15m)
	R16 (16m) ~ R20 (20m)

### Actuator Specifications

Item	Description
Drive system	Ball screw ø8mm, rolled C10
Positioning repeatability	±0.01mm
Lost motion	0.1mm or less
Rod	ø20mm Material: Aluminum with hard alumite treatment
Static allowable torque on rod tip	To: 1.0N·m
Max. angular displacement on rod tip (*1)	θ: ±1.0 deg.
Ambient operating temp. & humidity	0~40°C, 85% RH or less (Non-condensing)

(\*1) This is the displacement angle of the rod tip (initial reference value) when the rod is fully retracted and the static allowable torque is applied at the rod tip.

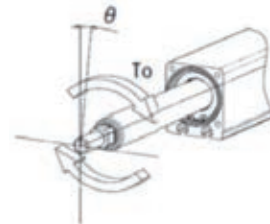

### Options

Name	Option Code	Reference Page
Brake	B	See P.131
Cable exit direction (Top)	CJT	See P.131
Cable exit direction (Bottom)	CJB	See P.131
Cable exit direction (Outside)	CJO	See P.131
Flange (*1)	FL	See P.132
Foot bracket	FT	See P.133
Motor side-mounted to left (standard)	ML	See P.135
Motor side-mounted to right	MR	See P.135
Tip adapter (Internal thread)	NFA	See P.135
Non-motor end specification	NM	See P.136
T-slot nut bar specification	NTB	See P.136
Back mounting plate	RP	See P.137
Round cable joint connector with screw locking (*2)	EU	See P.131

(\*1) Be sure to confirm with the "Selection Notes (P.138)" when selecting options. (\*2) EU option will be available soon.

## Dimensions

CAD drawings can be downloaded from our website.  
[www.robocylinder.de](http://www.robocylinder.de)



\*1 When the rod is returning to its home position, please be careful of interference from surrounding objects, as it will travel until it reaches the M.E.  
 M.E: Mechanical end S.E: Stroke end  
 \*2 The direction of width across flat varies depending on the product. Those flats cannot be used for vertical or horizontal reference plane.

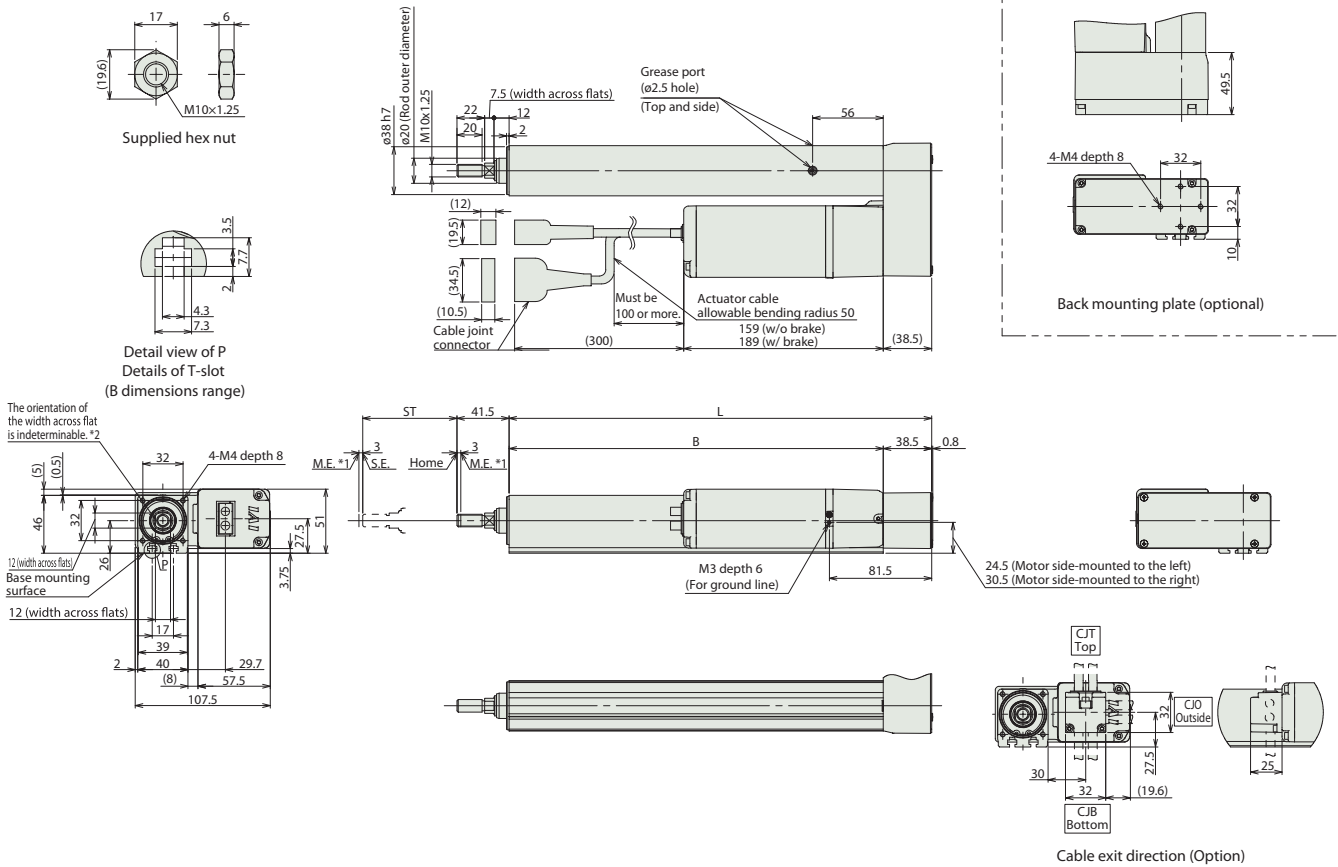

## Dimensions and Mass by Stroke

Stroke	50	100	150	200
L	186.5	236.5	286.5	336.5
B	148	198	248	298
Mass (kg)				
W/o brake	1.8	2.0	2.1	2.3
W/ brake	2.0	2.2	2.3	2.5

## Applicable Controllers

The RCS4 series actuators can be operated by the controllers indicated below. Please select the type depending on your intended use.

Name	External view	Max. number of connectable axes	Input power	Control method				Maximum number of positioning points	Reference page	
				Positioner	Pulse train	Program	Network * Option			
SCON-CB/CGB		1	Single phase 115V/230VAC	●	●	—	DeviceNet CC-Link CANopen EtherCAT EtherNet/IP Note: The type of compatible networks will vary depending on the controller. Please refer to the reference page for more information.	512 (768 for network spec.)	Please see P.151	
SCON-LC/LCG (*)		1		—	—	●		512 (768 for network spec.)		
SCON-CAL/CGAL		1		●	—	—		512 (768 for network spec.)		
MSCON-C		6		This model is network-compatible only.				256		
SSEL-CS		2		●	—	●		20000		
XSEL-P/Q or XSEL-RA/SA (*)		6 or 8 (Depending on the type)	Single phase 230VAC Three-phase 230VAC	—	—	●	20000 or 55000 (Depending on the type)	Please see the dedicated controller catalog or manual.		

(\*) Coming soon

Foreword  
 Slider Type  
 Wide Slider Type  
 Rod Type  
 Radial Cylinder  
 Wide Radial Cylinder  
 Table Type  
 Cleanroom Slider  
 Cleanroom Wide Slider  
 Options  
 Reference Data  
 Controller









## Dimensions

CAD drawings can be downloaded from our website.  
[www.robocylinder.de](http://www.robocylinder.de)



- \*1 When the rod is returning to its home position, please be careful of interference from surrounding objects, as it will travel until it reaches the M.E.  
 M.E: Mechanical end S.E: Stroke end
- \*2 The direction of width across flat varies depending on the product. Those flats cannot be used for vertical or horizontal reference plane.

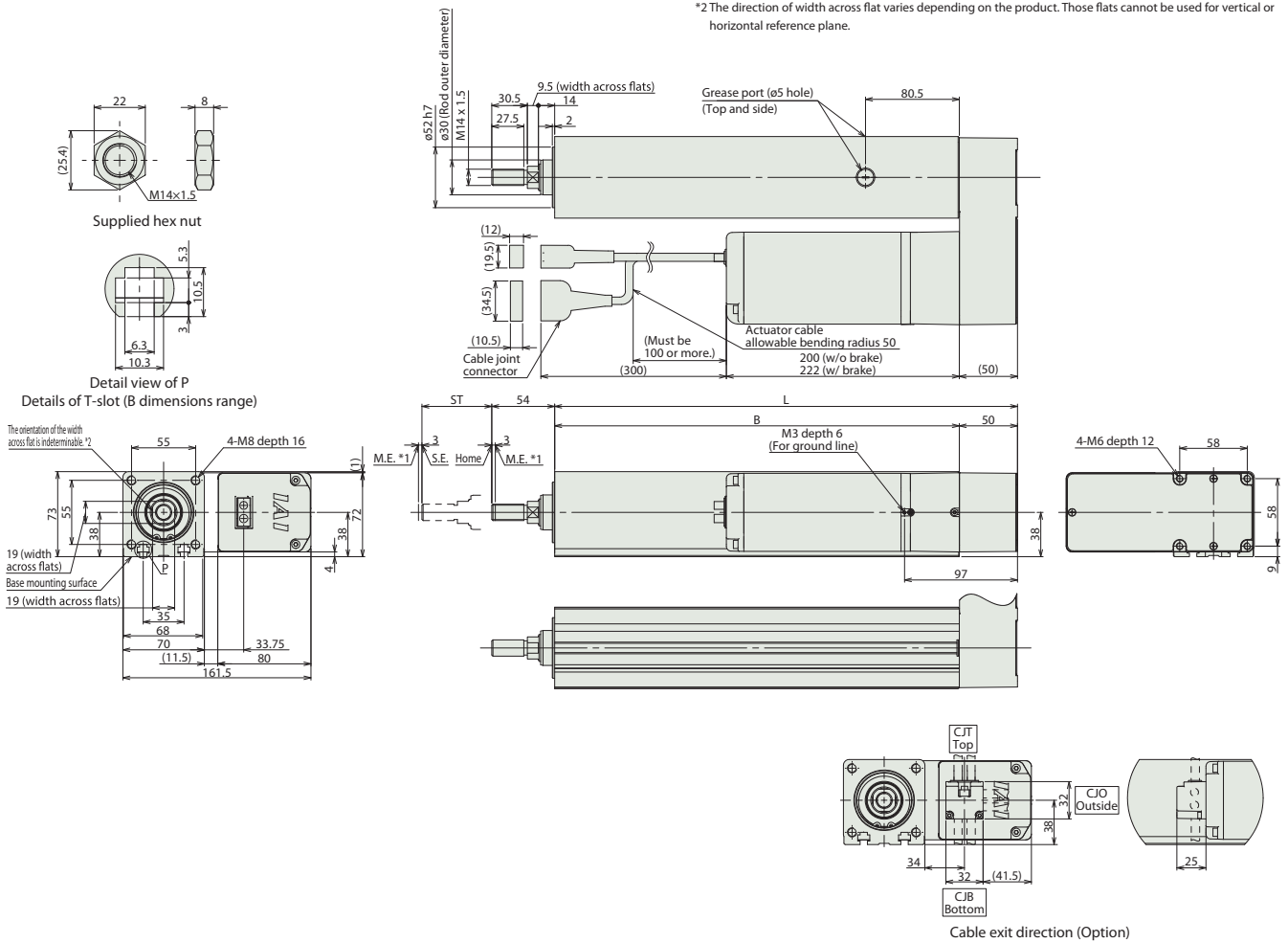

## Dimensions and Mass by Stroke

Stroke	50	100	150	200	250	300
L	247.5	297.5	347.5	397.5	447.5	497.5
B	197.5	247.5	297.5	347.5	397.5	447.5
Mass (kg)						
W/o brake	5.4	6.0	6.5	7.1	7.7	8.3
W/brake	5.9	6.5	7.0	7.6	8.2	8.8

## Applicable Controllers

The RCS4 series actuators can be operated by the controllers indicated below. Please select the type depending on your intended use.

Name	External view	Max. number of connectable axes	Input power	Control method				Maximum number of positioning points	Reference page
				Positioner	Pulse train	Program	Network * Option		
SCON-CB/CGB		1	Single phase 115V/230VAC	●	●	—	DeviceNet CC-Link CANopen EtherCAT EtherNet/IP	512 (768 for network spec.)	Please see the dedicated controller catalog or manual.
SCON-LC/LCG (*)		1		—	—	●		512 (768 for network spec.)	
SCON-CAL/CGAL		1		●	—	—		512 (768 for network spec.)	
MSCON-C		6		This model is network-compatible only.				256	
SSEL-CS		2		●	—	●	20000		
XSEL-P/Q or XSEL-RA/SA (*)		6 or 8 (Depending on the type)	Single phase 230VAC Three-phase 230VAC	—	—	●	20000 or 55000 (Depending on the type)		

(\*) Coming soon

Foreword  
 Slider Type  
 Wide Slider Type  
 Rod Type  
 Radial Cylinder  
 Wide Radial Cylinder  
 Table Type  
 Cleanroom Slider  
 Cleanroom Wide Slider  
 Options  
 Reference Data  
 Controller



## Dimensions

CAD drawings can be downloaded from our website.  
www.robocylinder.de



- \*1 When the rod is returning to its home position, please be careful of interference from surrounding objects, as it will travel until it reaches the M.E.  
M.E: Mechanical end S.E: Stroke end
- \*2 The direction of width across flat varies depending on the product. Those flats cannot be used for vertical or horizontal reference plane.

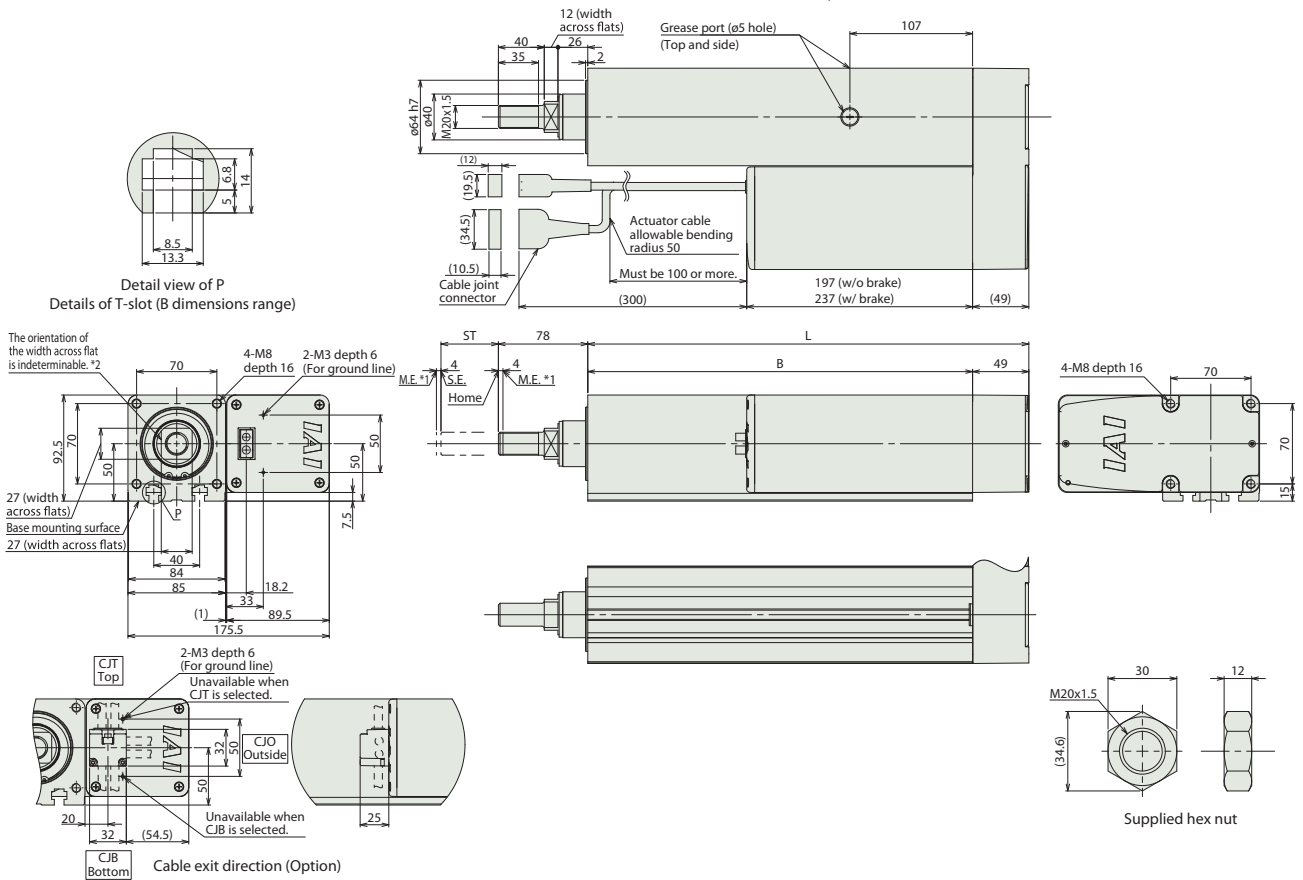

### Dimensions and Mass by Stroke

Stroke	50	100	150	200	250	300
L	284.5	334.5	384.5	434.5	484.5	534.5
B	235.5	285.5	335.5	385.5	435.5	485.5
Mass (kg)						
W/o brake	9.6	10.4	11.2	12.1	12.9	13.8
W/brake	10.2	11.0	11.8	12.7	13.5	14.4

### Applicable Controllers

The RCS4 series actuators can be operated by the controllers indicated below. Please select the type depending on your intended use.

Name	External view	Max. number of connectable axes	Input power	Control method				Maximum number of positioning points	Reference page
				Positioner	Pulse train	Program	Network * Option		
SCON-CB/CGB		1	Single phase 230VAC	●	●	—	DeviceNet CC-Link CompoNet EtherCAT EtherNet/IP	512 (768 for network spec.)	Please see P.151
SCON-LC/LCG (*)		1		—	—	●		512 (768 for network spec.)	
SSEL-CS		2	Single phase 115V/230VAC	●	—	●	Note: The type of compatible networks will vary depending on the controller. Please refer to the reference page for more information.	20000	Please see the dedicated controller catalog or manual.
XSEL-P/Q or XSEL-RA/SA (*)		6 or 8 (Depending on the type)	Single phase 230VAC Three-phase 230VAC	—	—	●		20000 or 55000 (Depending on the type)	

(\*) Coming soon

Foreword  
Slider Type  
Wide Slider Type  
Rod Type  
Radial Cylinder  
Wide Radial Cylinder  
Table Type  
Cleanroom Slider  
Cleanroom Wide Slider  
Options  
Reference Data  
Controller

# RCS4-RAA4C

Battery-less Absolute
Motor Unit Coupled
Straight Motor
Body Width 40mm
230v AC Servo Motor

Model Specification Items	<b>RCS4</b> — <b>RRA4C</b> — <b>WA</b> — <b>60</b> — [ ] — [ ] — <b>T2</b> — [ ] — [ ]							
Series	Type	Encoder Type	Motor Type	Lead	Stroke	Applicable Controllers	Cable Length	Options
		WA: Battery-less Absolute	60: Servo motor 60W	16: 16mm 10: 10mm 5: 5mm 2.5: 2.5mm	60: 60mm + 410: 410mm (50mm increments)	T2: SCON MSCON SSEL XSEL-P/Q XSEL-RA/SA	N: None P: 1m S: 3m M: 5m X [ ] : Specified Length R [ ] : Robot Cable	Refer to Options table below.

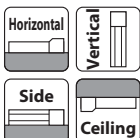

\* Depending on the model, there may be some limitations to using the vertical, side, and ceiling mount positions. Please refer to the Selection Notes on P.138 for more information.



- Both the horizontal and vertical payloads assume operation at an acceleration of 0.3G.
- When the acceleration is increased, the payload will be reduced. Please refer to "Table of Payload by Acceleration" on P.139 for more details.
- Estimated allowable duty varies depending on operating conditions (payload, acceleration/deceleration, etc.). Please refer to P. 149 for more information.
- The radial cylinder is equipped with a built-in guide. Please refer to the graphs shown on P.145 and after for the allowable load mass.

## Actuator Specifications

### Lead and Payload

Model Number	Motor wattage (W)	Lead (mm)	Max. payload		Rated thrust (N)	Stroke (mm)
			Horizontal (kg)	Vertical (kg)		
RCS4-RRA4C-WA-60-16-①-T2-②-③	60	16	8	2	53	60~410 (50mm increments)
RCS4-RRA4C-WA-60-10-①-T2-②-③		10	18	4	85	
RCS4-RRA4C-WA-60-5-①-T2-②-③		5	30	6	170	
RCS4-RRA4C-WA-60-2.5-①-T2-②-③		2.5	40	10	340	

Legend: ① Stroke ② Cable Length ③ Option

### Stroke and Max Speed (Unit: mm/s)

Lead	Stroke	
	60~410 (50mm increments)	
16	960	
10	600	
5	300	
2.5	150	

## Cable Length

Type	Cable Code
Standard	P (1m)
	S (3m)
	M (5m)
Specified length (Standard cable)	X06 (6m) ~ X10 (10m)
	X11 (11m) ~ X15 (15m)
	X16 (16m) ~ X20 (20m)
	R01 (1m) ~ R03 (3m)
Robot cable	R04 (4m) ~ R05 (5m)
	R06 (6m) ~ R10 (10m)
	R11 (11m) ~ R15 (15m)
	R16 (16m) ~ R20 (20m)

## Actuator Specifications

Item	Description
Drive system	Ball screw ø8mm, rolled C10
Positioning repeatability	±0.01mm
Lost motion	0.1mm or less
Rod	ø20mm Material: Aluminum with hard alumite treatment
Rod non-rotation precision (*1)	0 degrees
Allowable load and torque on rod tip	Please see P. 60
Rod tip offset/overhang distance	dx/dz: 100mm or less
Ambient operating temp. & humidity	0~40°C, 85% RH or less (Non-condensing)

(\*1) Rod's angular displacement in rotational direction with no load applied to the rod.

Offset distance at end of rod (dx: 100mm or less)

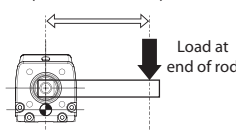

Overhang distance at end of rod (dz: 100mm or less)

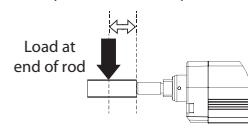

## Options

Name	Option Code	Reference Page
Brake	B	See P.131
Cable exit direction (Top)	CJT	See P.131
Cable exit direction (Right)	CJR	See P.131
Cable exit direction (Left)	CJL	See P.131
Cable exit direction (Bottom)	CJB	See P.131
Flange	FL	See P.132
Tip adapter (Flange)	FFA	See P.131
Tip adapter (Keyway)	KFA	See P.134
Tip adapter (Internal thread)	NFA	See P.135
Non-motor end specification	NM	See P.136

Round cable joint connector with screw locking (*1)	EU	See P.131
---	----	-----------

(\*1) EU option will be available soon.

## Dimensions

CAD drawings can be downloaded from our website.  
www.robocylinder.de

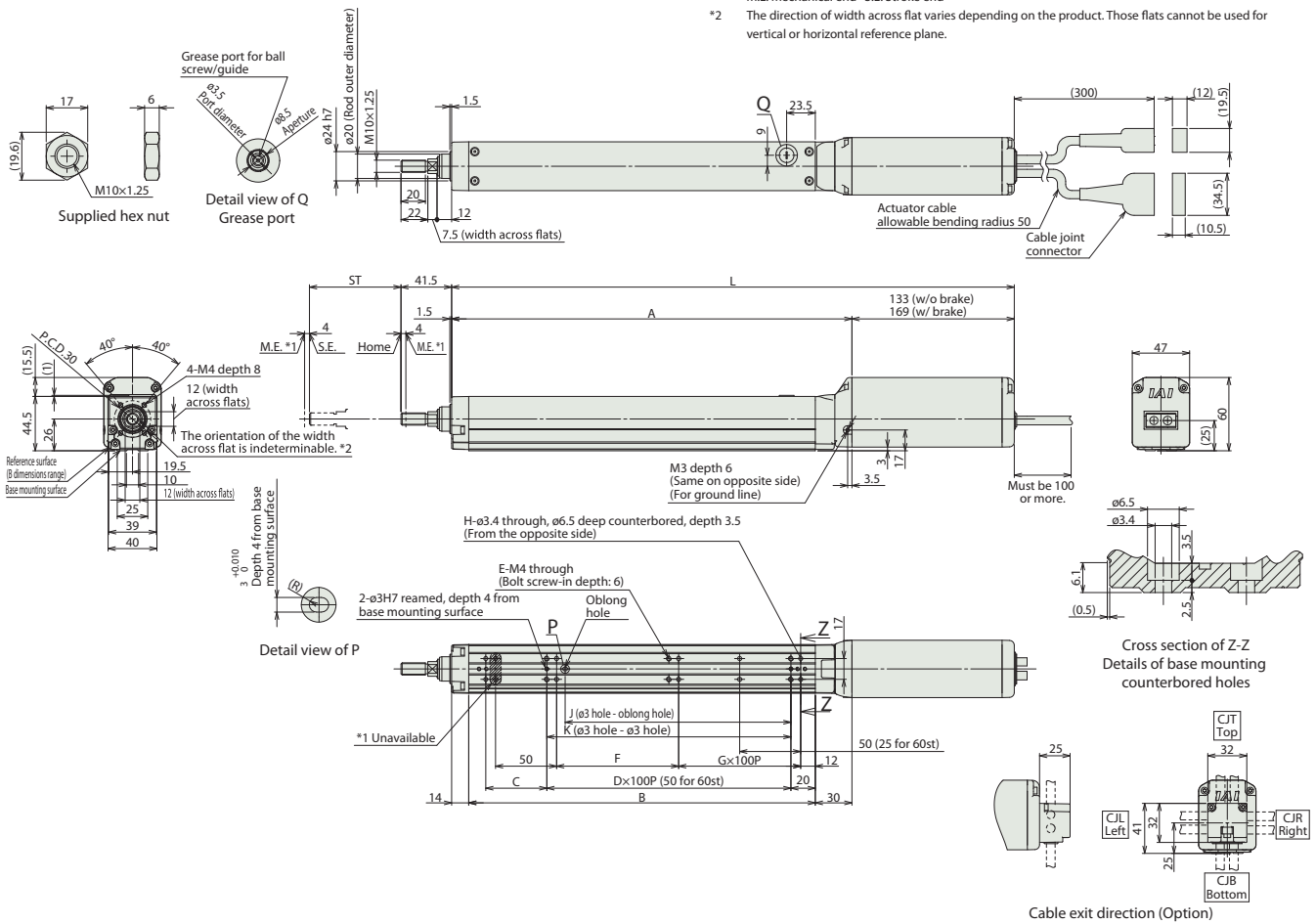

- \*1 The two mounting holes (H) on the rod side of the top surface cannot be used. (Note) When the rod is returning to its home position, please be mindful of possible interference from surrounding objects, as it will travel until it reaches the M.E.
- \*2 The direction of width across flat varies depending on the product. Those flats cannot be used for vertical or horizontal reference plane.

## Dimensions and Mass by Stroke

Stroke	Stroke								
	60	110	160	210	260	310	360	410	
L	W/o brake	311	361	411	461	511	561	611	661
	W/brake	347	397	447	497	547	597	647	697
A	178	228	278	328	378	428	478	528	
B	134	184	234	284	334	384	434	484	
C	50	50	100	50	100	50	100	50	
D	0	1	1	2	2	3	3	4	
E	6	6	6	8	8	10	10	12	
F	50	100	50	100	50	100	50	100	
G	0	0	1	1	2	2	3	3	
H (*)	6	6	8	8	10	10	12	12	
J	35	85	85	185	185	285	285	385	
K	50	100	100	200	200	300	300	400	
Allowable static load on rod tip (N)		63.4	50.7	42.1	36.0	31.3	27.6	24.6	22.2
Allowable dynamic load on rod tip (5000km life) (N)	Load offset 0mm	28.9	22.2	17.9	14.8	12.6	10.8	9.4	8.2
	Load offset 100mm	17.9	15.5	13.4	11.6	10.2	9.0	8.0	7.1
Allowable static torque on rod tip (N-m)		6.4	5.1	4.3	3.7	3.2	2.9	2.6	2.3
Allowable dynamic torque on rod tip (N-m)		1.7	1.5	1.3	1.1	1.0	0.9	0.7	0.7
Mass (kg)	W/o brake	1.3	1.3	1.4	1.5	1.6	1.7	1.8	1.9
	W/brake	1.6	1.6	1.7	1.8	1.9	2.0	2.1	2.2

(\*) Does not include holes that are not available.

## Rod Deflection of RCS4-RR4C (Reference Values)

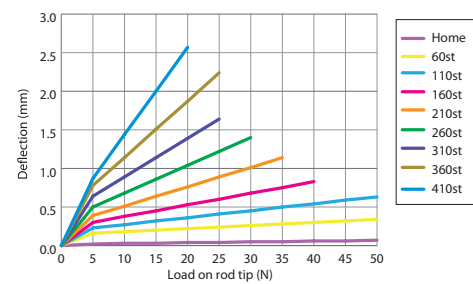

## Applicable Controllers

The RCS4 series actuators can be operated by the controllers indicated below. Please select the type depending on your intended use.

Name	External view	Max. number of connectable axes	Input power	Control method				Maximum number of positioning points	Reference page
				Positioner	Pulse train	Program	Network * Option		
SCON-CB/CGB		1	Single phase 115V/230VAC	●	●	—	DeviceNet CC-Link PROFINET EtherCAT EtherNet/IP	512 (768 for network spec.)	Please see P.151
SCON-LC/LCG (*)		1		—	—	●		512 (768 for network spec.)	
SCON-CAL/CGAL		1		●	—	—		512 (768 for network spec.)	
MSCON-C		6		This model is network-compatible only.				256	
SSEL-CS		2		●	—	●	20000		
XSEL-P/Q or XSEL-RA/SA (*)		6 or 8 (Depending on the type)	Single phase 230VAC Three-phase 230VAC	—	—	●	20000 or 55000 (Depending on the type)	Please see the dedicated controller catalog or manual.	
Note: The type of compatible networks will vary depending on the controller. Please refer to the reference page for more information.									

(\*) Coming soon

Foreword  
Slider Type  
Wide Slider Type  
Rod Type  
Radial Cylinder®  
Wide Radial Cylinder  
Table Type  
Cleanroom Slider  
Cleanroom Wide Slider  
Options  
Reference Data  
Controller

# RCS4-RRR6C

Battery-less Absolute
Motor Unit Coupled
Straight Motor
Body Width 60 mm
230v AC Servo Motor

Model Specification Items	<b>RCS4</b> — <b>RRR6C</b> — <b>WA</b> — <b>100</b> — [ ] — [ ] — <b>T2</b> — [ ] — [ ]							
Series	Type	Encoder Type	Motor Type	Lead	Stroke	Applicable Controllers	Cable Length	Options
WA: Battery-less Absolute	100: Servo motor 100W	20: 20mm 12: 12mm 6: 6mm 3: 3mm	65: 65mm 415: 415mm (50mm increments)	T2: SCON MSCON SSEL XSEL-P/Q XSEL-RA/SA	N: None P: 1m S: 3m M: 5m X [ ] : Specified Length R [ ] : Robot Cable	Refer to Options table below.		



\* Depending on the model, there may be some limitations to using the vertical, side, and ceiling mount positions. Please refer to the Selection Notes on P.138 for more information.



- (1) Both the horizontal and vertical payloads assume operation at an acceleration of 0.3G.
- (2) When the acceleration is increased, the payload will be reduced. Please refer to "Table of Payload by Acceleration" on P.139 for more details.
- (3) Estimated allowable duty varies depending on operating conditions (payload, acceleration/deceleration, etc.). Please refer to P. 149 for more information.
- (4) The radial cylinder is equipped with a built-in guide. Please refer to the graphs shown on P.145 and after for the allowable load mass.

## Actuator Specifications

### Lead and Payload

Model Number	Motor wattage (W)	Lead (mm)	Max. payload		Rated thrust (N)	Stroke (mm)
			Horizontal (kg)	Vertical (kg)		
RCS4-RRR6C-WA-100-20-①-T2-②-③	100	20	15	4	85	65~415 (50mm increments)
RCS4-RRR6C-WA-100-12-①-T2-②-③		12	25	10	142	
RCS4-RRR6C-WA-100-6-①-T2-②-③		6	50	20	283	
RCS4-RRR6C-WA-100-3-①-T2-②-③		3	60	20	566	

Legend: ① Stroke ② Cable Length ③ Option

### Stroke and Max Speed (Unit: mm/s)

Lead	Stroke	
	65~415 (50mm increments)	
20	1200	
12	720	
6	360	
3	180	

## Cable Length

Type	Cable Code
Standard	P (1m)
	S (3m)
	M (5m)
Specified length (Standard cable)	X06 (6m) ~ X10 (10m)
	X11 (11m) ~ X15 (15m)
	X16 (16m) ~ X20 (20m)
	R01 (1m) ~ R03 (3m)
Robot cable	R04 (4m) ~ R05 (5m)
	R06 (6m) ~ R10 (10m)
	R11 (11m) ~ R15 (15m)
	R16 (16m) ~ R20 (20m)

## Actuator Specifications

Item	Description
Drive system	Ball screw ø10mm, rolled C10
Positioning repeatability	±0.01mm
Lost motion	0.1mm or less
Rod	ø25mm Material: Aluminum with hard alumite treatment
Rod non-rotation precision (*1)	0 degrees
Allowable load and torque on rod tip	Please see P. 62
Rod tip offset/overhang distance	dx/dz: 100mm or less
Ambient operating temp. & humidity	0~40°C, 85% RH or less (Non-condensing)

(\*1) Rod's angular displacement in rotational direction with no load applied to the rod.

Offset distance at end of rod (dx: 100mm or less)

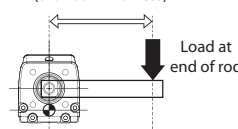

Overhang distance at end of rod (dz: 100mm or less)

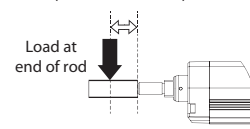

## Options

Name	Option Code	Reference Page
Brake	B	See P.131
Cable exit direction (Top)	CJT	See P.131
Cable exit direction (Right)	CJR	See P.131
Cable exit direction (Left)	CJL	See P.131
Cable exit direction (Bottom)	CJB	See P.131
Flange	FL	See P.132
Tip adapter (Flange)	FFA	See P.131
Tip adapter (Keyway)	KFA	See P.134
Tip adapter (Internal thread)	NFA	See P.135
Non-motor end specification	NM	See P.136

Round cable joint connector with screw locking (*1)	EU	See P.131
---	----	-----------

(\*1) EU option will be available soon.



# RCS4-RAA7C

Battery-less Absolute
Motor Unit Coupled
Straight Motor
Body Width 70mm
230v AC Servo Motor

Model Specification Items	<b>RCS4</b> — <b>RRA7C</b> — <b>WA</b> — <b>200</b> — [ ] — [ ] — <b>T2</b> — [ ] — [ ]							
Series	Type	Encoder Type	Motor Type	Lead	Stroke	Applicable Controllers	Cable Length	Options
WA: Battery-less Absolute	200: Servo motor 200W	24:24mm 16:16mm 8: 8mm 4: 4mm	70:70mm 520:520mm (50mm increments)	T2:SCON MSCON SSEL XSEL-P/Q XSEL-RA/SA	N : None P : 1m S : 3m M : 5m X□□ : Specified Length R□□ : Robot Cable	Refer to Options table below.		

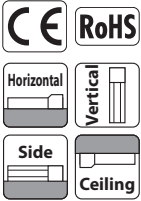

\* Depending on the model, there may be some limitations to using the vertical, side, and ceiling mount positions. Please refer to the Selection Notes on P.138 for more information.



**POINT Selection Notes**

- (1) Both the horizontal and vertical payloads assume operation at an acceleration of 0.3G.
- (2) When the acceleration is increased, the payload will be reduced. Please refer to "Table of Payload by Acceleration" on P.139 for more details.
- (3) Estimated allowable duty varies depending on operating conditions (payload, acceleration/deceleration, etc.). Please refer to P. 149 for more information.
- (4) The radial cylinder is equipped with a built-in guide. Please refer to the graphs shown on P.145 and after for the allowable load mass.

## Actuator Specifications

### Lead and Payload

Model Number	Motor wattage (W)	Lead (mm)	Max. payload		Rated thrust (N)	Stroke (mm)
			Horizontal (kg)	Vertical (kg)		
RCS4-RRA7C-WA-200-24-①-T2-②-③	200	24	20	6	142	70~520 (50mm increments)
RCS4-RRA7C-WA-200-16-①-T2-②-③		16	45	12	214	
RCS4-RRA7C-WA-200-8-①-T2-②-③		8	60	25	427	
RCS4-RRA7C-WA-200-4-①-T2-②-③		4	80	35	855	

Legend: ① Stroke ② Cable Length ③ Option

### Stroke and Max Speed (Unit: mm/s)

Lead	Stroke	70~520 (50mm increments)
24		1440
16		960
8		480
4		240

## Cable Length

Type	Cable Code
Standard	P (1m)
	S (3m)
	M (5m)
Specified length (Standard cable)	X06 (6m) ~ X10 (10m)
	X11 (11m) ~ X15 (15m)
	X16 (16m) ~ X20 (20m)
	R01 (1m) ~ R03 (3m)
Robot cable	R04 (4m) ~ R05 (5m)
	R06 (6m) ~ R10 (10m)
	R11 (11m) ~ R15 (15m)
	R16 (16m) ~ R20 (20m)

## Actuator Specifications

Item	Description
Drive system	Ball screw ø12mm, rolled C10
Positioning repeatability	±0.01mm
Lost motion	0.1mm or less
Rod	ø30mm Material: Aluminum with hard alumite treatment
Rod non-rotation precision (*1)	0 degrees
Allowable load and torque on rod tip	Please see P. 64
Rod tip offset/overhang distance	dx/dz: 150mm or less
Ambient operating temp. & humidity	0~40°C, 85% RH or less (Non-condensing)

(\*1) Rod's angular displacement in rotational direction with no load applied to the rod.

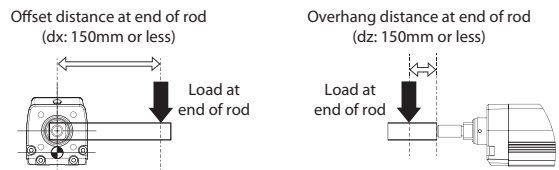

## Options

Name	Option Code	Reference Page
Brake	B	See P.131
Cable exit direction (Top)	CJT	See P.131
Cable exit direction (Right)	CJR	See P.131
Cable exit direction (Left)	CJL	See P.131
Cable exit direction (Bottom)	CJB	See P.131
Flange	FL	See P.132
Tip adapter (Flange)	FFA	See P.131
Tip adapter (Keyway)	KFA	See P.134
Tip adapter (Internal thread)	NFA	See P.135
Non-motor end specification	NM	See P.136

Round cable joint connector with screw locking (*1)	EU	See P.131
---	----	-----------

(\*1) EU option will be available soon.



## Dimensions

CAD drawings can be downloaded from our website.  
www.robocylinder.de



\*1 When the rod is returning to its home position, please be careful of interference from surrounding objects, as it will travel until it reaches the M.E.  
M.E: Mechanical end S.E: Stroke end  
\*2 The direction of width across flat varies depending on the product. Those flats cannot be used for vertical or horizontal reference plane.

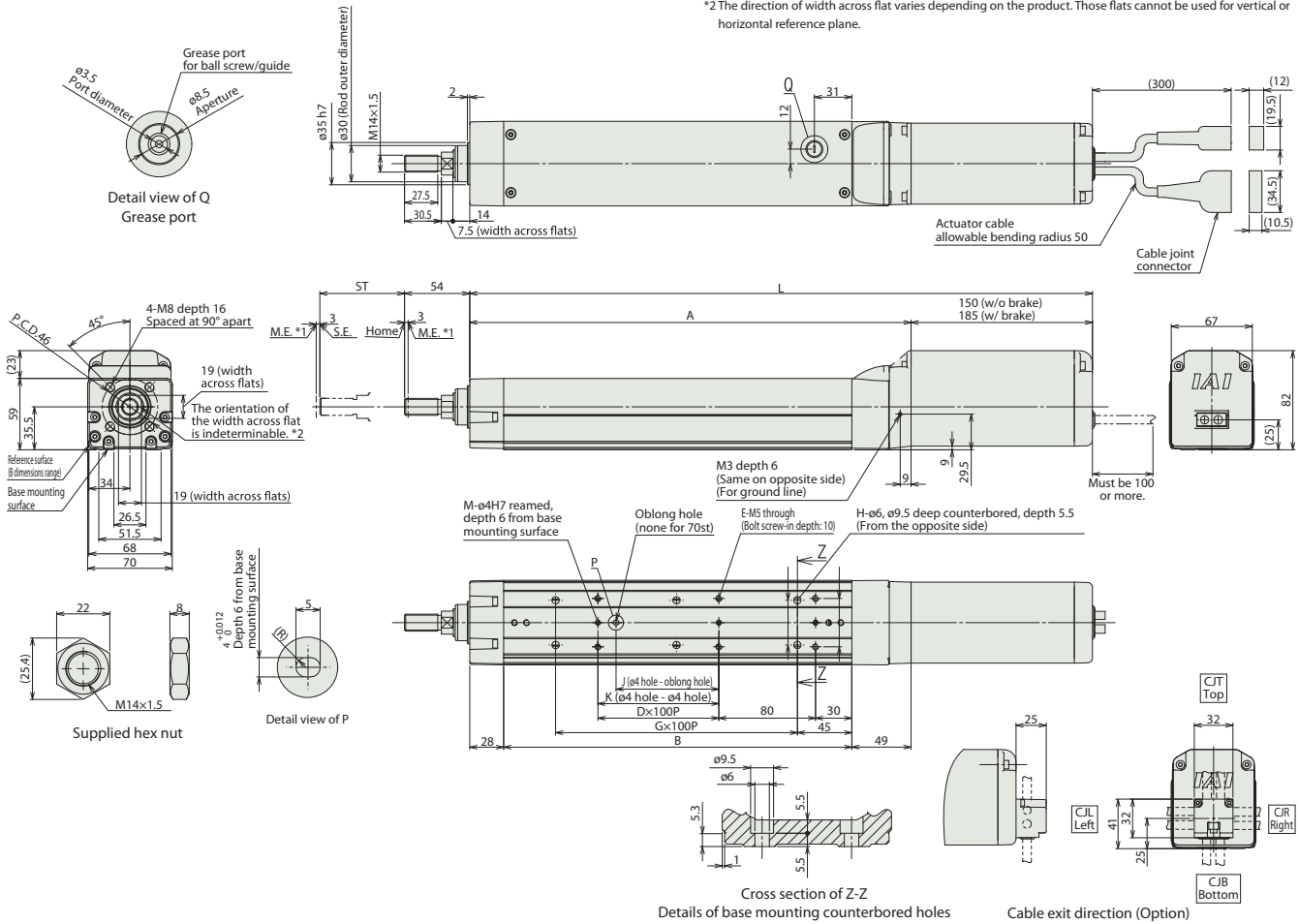

### Dimensions and Mass by Stroke

Stroke	L										
	70	120	170	220	270	320	370	420	470	520	
W/o brake	415	465	515	565	615	665	715	765	815	865	
	450	500	550	600	650	700	750	800	850	900	
A	265	315	365	415	465	515	565	615	665	715	
B	188	238	288	338	388	438	488	538	588	638	
D	0	1	1	2	2	3	3	4	4	5	
E	4	6	6	8	8	10	10	12	12	14	
G	1	1	2	2	3	3	4	4	5	5	
H	4	4	6	6	8	8	10	10	12	12	
J	0	85	85	185	185	285	285	385	385	485	
K	0	0	100	200	200	300	300	400	400	500	
M	2	2	3	3	3	3	3	3	3	3	
Allowable static load on rod tip (N)	175	147	126	111	98.6	88.7	80.6	73.8	68	63	
Allowable dynamic load on rod tip (5000km life) (N)	75.7	62.6	53.1	46.0	40.5	36.1	32.5	29.4	26.9	24.7	
Allowable static torque on rod tip (N-m)	17.6	14.7	12.7	11.2	9.9	9.0	8.2	7.5	6.94	6.45	
Allowable dynamic torque on rod tip (N-m)	5.0	4.5	4.0	3.6	3.3	3.0	2.8	2.5	2.32	2.16	
Mass (kg)	W/o brake	3.7	4.0	4.2	4.5	4.8	5.0	5.3	5.6	6.1	
	W/brake	4.2	4.5	4.7	5.0	5.3	5.5	5.8	6.1	6.6	

### Rod Deflection of RCS4-RR47C (Reference Values)

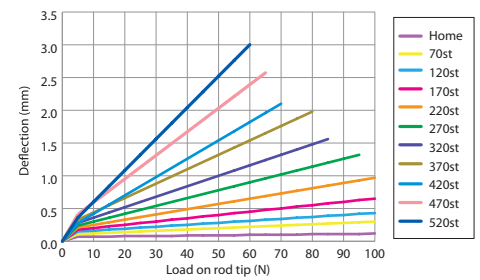

### Applicable Controllers

The RCS4 series actuators can be operated by the controllers indicated below. Please select the type depending on your intended use.

Name	External view	Max. number of connectable axes	Input power	Control method				Maximum number of positioning points	Reference page	
				Positioner	Pulse train	Program	Network * Option			
SCON-CB/CGB		1	Single phase 115V/230VAC	●	●	—	DeviceNet CCLink PROFINET CompoNet EtherCAT EtherNet/IP	512 (768 for network spec.)	Please see P.151	
SCON-LC/LCG (*)		1		—	—	●		512 (768 for network spec.)		
SCON-CAL/CGAL		1		●	—	—		512 (768 for network spec.)		
MSCON-C		6		This model is network-compatible only.				256		
SSEL-CS		2		●	—	●		20000		
XSEL-P/Q or XSEL-RA/SA (*)		6 or 8 (Depending on the type)	Single phase 230VAC Three-phase 230VAC	—	—	●	20000 or 55000 (Depending on the type)	Please see the dedicated controller catalog or manual.		
Note: The type of compatible networks will vary depending on the controller. Please refer to the reference page for more information.										

(\*) Coming soon

Foreword  
 Slider Type  
 Wide Slider Type  
 Rod Type  
 Radial Cylinder  
 Wide Radial Cylinder  
 Table Type  
 Cleanroom Slider  
 Cleanroom Wide Slider  
 Options  
 Reference Data  
 Controller

# RCS4-RRR8C

Battery-less Absolute
Motor Unit Coupled
Straight Motor
Body Width 90 mm
230v AC Servo Motor

Model Specification Items	<b>RCS4</b>	<b>RRR8C</b>	<b>WA</b>	<b>400</b>			<b>T2</b>		
	Series	Type	Encoder Type	Motor Type	Lead	Stroke	Applicable Controllers	Cable Length	Options
			WA: Battery-less Absolute	400: Servo motor 400W	30:30mm 20:20mm 10:10mm 5: 5mm	50:50mm 700:700mm (50mm increments)	T2:SCON SSEL XSEL-P/Q XSEL-RA/SA	N: None P: 1m S: 3m M: 5m	Refer to Options table below.

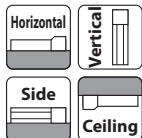

\* Depending on the model, there may be some limitations to using the vertical, side, and ceiling mount positions. Please refer to the Selection Notes on P.138 for more information.

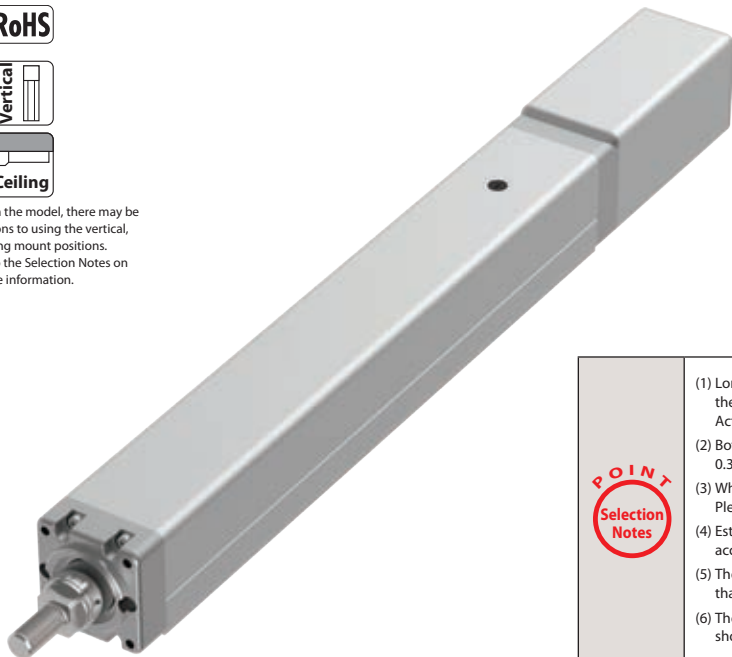

- Longer strokes may cause the maximum speed to decrease due to resonance of the ball screw. Be sure to check the maximum speed of the desired stroke in the Actuator Specifications table, which can be found below.
- Both the horizontal and vertical payloads assume operation at an acceleration of 0.3G. (0.2G for lead 5).
- When the acceleration is increased, the payload will be reduced. Please refer to "Table of Payload by Acceleration" on P.139 for more details.
- Estimated allowable duty varies depending on operating conditions (payload, acceleration/deceleration, etc.). Please refer to P. 149 for more information.
- The value of the maximum payload assumes that there is an external guide and that the rod is not subjected to external force other than in the moving direction.
- The radial cylinder is equipped with a built-in guide. Please refer to the graphs shown on P.145 and after for the allowable load mass.

## Actuator Specifications

### Lead and Payload

Model Number	Motor wattage (W)	Lead (mm)	Max. payload		Rated thrust (N)	Stroke (mm)
			Horizontal (kg)	Vertical (kg)		
RCS4-RRR8C-WA-400-30-①-T2-②-③	400	30	30	8	226	50~700 (50mm increments)
RCS4-RRR8C-WA-400-20-①-T2-②-③		20	60	20	339	
RCS4-RRR8C-WA-400-10-①-T2-②-③		10	80	40	678	
RCS4-RRR8C-WA-400-5-①-T2-②-③		5	100	72	1357	

Legend: ① Stroke ② Cable Length ③ Option

### Stroke and Max Speed

(Unit: mm/s)

Stroke	Lead									
	50~250 (50mm increments)	300	350	400	450	500	550	600	650	700
30	1500	1500	1230	970	790	650	540	460	400	350
20	1100	1070	820	650	520	430	360	310	260	230
10	550	520	400	310	250	210	180	150	130	110
5	275	250	190	150	120	100	80	70	60	55

## Cable Length

Type	Cable Code
Standard	P (1m)
	S (3m)
	M (5m)
Specified length (Standard cable)	X06 (6m) ~ X10 (10m)
	X11 (11m) ~ X15 (15m)
	X16 (16m) ~ X20 (20m)
	R01 (1m) ~ R03 (3m)
Robot cable	R04 (4m) ~ R05 (5m)
	R06 (6m) ~ R10 (10m)
	R11 (11m) ~ R15 (15m)
	R16 (16m) ~ R20 (20m)
	R16 (16m) ~ R20 (20m)

## Actuator Specifications

Item	Description
Drive system	Ball screw ø16mm, rolled C10
Positioning repeatability	±0.01mm
Lost motion	0.1mm or less
Rod	ø40mm Material: Aluminum with hard alumite treatment
Rod non-rotation precision (*1)	0 degrees
Allowable load and torque on rod tip	Please see P. 66
Rod tip offset/overhang distance	dx/dz: 150mm or less
Ambient operating temp. & humidity	0~40°C, 85% RH or less (Non-condensing)

(\*1) Rod's angular displacement in rotational direction with no load applied to the rod.

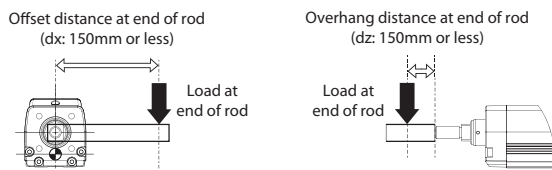

## Options

Name	Option Code	Reference Page
Brake	<b>B</b>	See P.131
Cable exit direction (Top)	<b>CJT</b>	See P.131
Cable exit direction (Right)	<b>CJR</b>	See P.131
Cable exit direction (Left)	<b>CJL</b>	See P.131
Cable exit direction (Bottom)	<b>CJB</b>	See P.131
Flange	<b>FL</b>	See P.132
Tip adapter (Internal thread)	<b>NFA</b>	See P.135
Non-motor end specification	<b>NM</b>	See P.136

Round cable joint connector with screw locking (*1)	<b>EU</b>	See P.131
---	-----------	-----------

## Dimensions

CAD drawings can be downloaded from our website.

www.robocylinder.de



\*1 When the rod is returning to its home position, please be careful of interference from surrounding objects, as it will travel until it reaches the M.E.

M.E: Mechanical end S.E: Stroke end

\*2 The direction of width across flat varies depending on the product. Those flats cannot be used for vertical or horizontal reference plane.

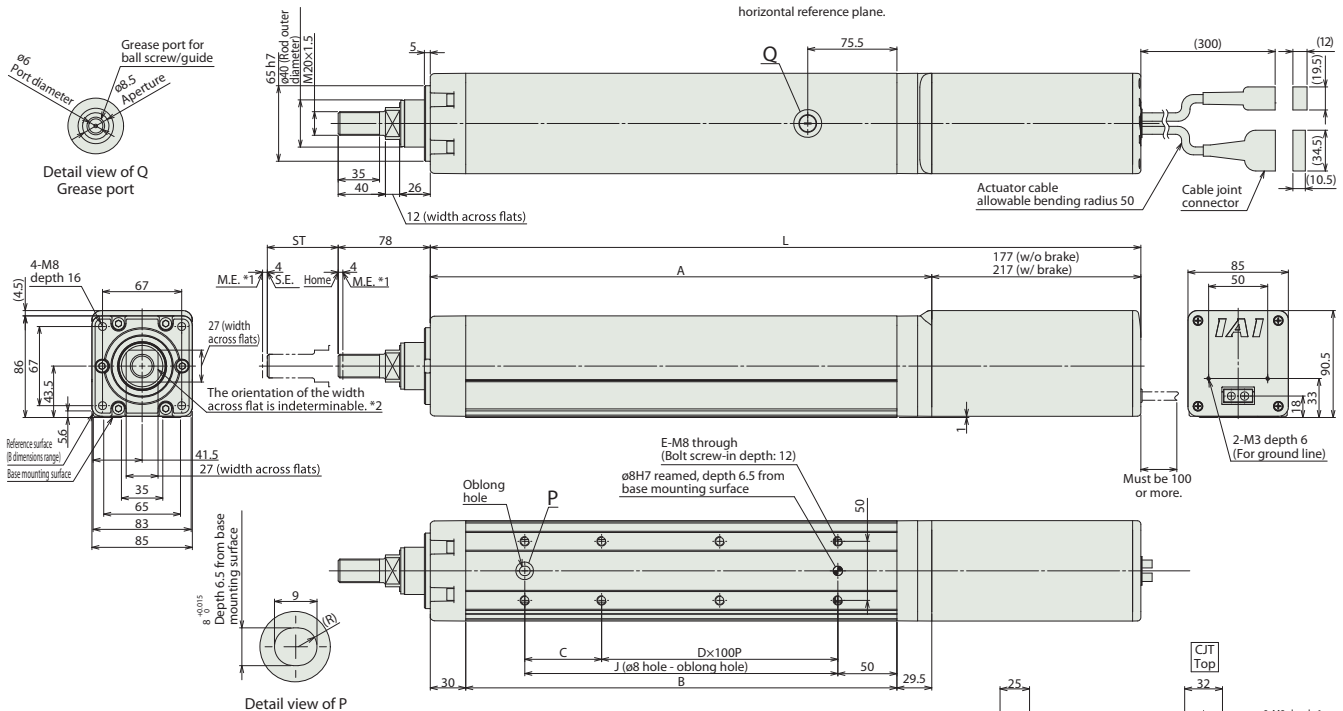

### ■ Rod Deflection of RCS4-RR8C (Reference Values)

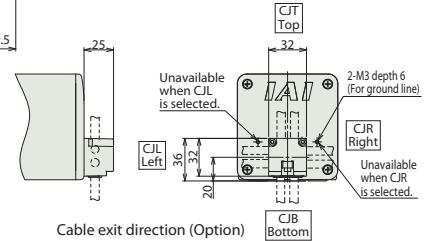
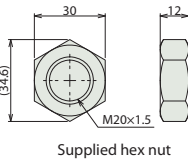
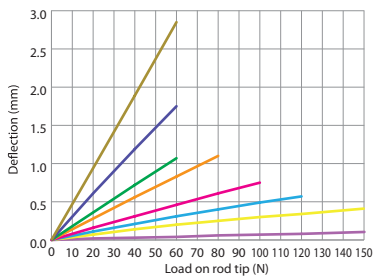

### ■ Dimensions and Mass by Stroke

Stroke	Stroke														
	50	100	150	200	250	300	350	400	450	500	550	600	650	700	
L	W/o brake	451.5	501.5	551.5	601.5	651.5	701.5	751.5	801.5	851.5	901.5	951.5	1001.5	1051.5	1101.5
	W/brake	491.5	541.5	591.5	641.5	691.5	741.5	791.5	841.5	891.5	941.5	991.5	1041.5	1091.5	1141.5
A	274.5	324.5	374.5	424.5	474.5	524.5	574.5	624.5	674.5	724.5	774.5	824.5	874.5	924.5	
B	215	265	315	365	415	465	515	565	615	665	715	765	815	865	
C	115	65	115	65	115	65	115	65	115	65	115	65	115	65	
D	0	1	1	2	2	3	3	4	4	5	5	6	6	7	
E	4	6	6	8	8	10	10	12	12	14	14	16	16	18	
J	115	165	215	265	315	365	415	465	515	565	615	665	715	765	
Allowable static load on rod tip (N)		222	186	159	139	124	111	101	92	84.7	78.4	72.8	68	63.7	59.8
Allowable dynamic load on rod tip (5000km life) (N)	Load offset 0mm	93	76.3	64.7	56	49.2	43.8	39.3	35.6	32.4	29.7	27.3	25.2	23.3	21.7
	Load offset 100mm	72	61.6	53.9	48	43	38.9	35.4	32.3	29.7	27.4	25.3	23.5	21.9	20.4
Allowable static torque on rod tip (N-m)		22.3	18.7	16.1	14.1	12.6	11.3	10.3	9.4	8.7	8.1	7.6	7.1	6.7	6.3
Allowable dynamic torque on rod tip (N-m)		7.2	6.2	5.4	4.8	4.3	3.9	3.5	3.2	3	2.7	2.5	2.4	2.2	2
Mass (kg)	W/o brake	6.6	7.1	7.6	8.1	8.6	9.1	9.5	10.0	10.5	11.0	11.5	12.0	12.4	12.9
	W/brake	7.2	7.7	8.2	8.7	9.2	9.7	10.1	10.6	11.1	11.6	12.1	12.6	13.0	13.5

### ■ Applicable Controllers

The RCS4 series actuators can be operated by the controllers indicated below. Please select the type depending on your intended use.

Name	External view	Max. number of connectable axes	Input power	Control method				Maximum number of positioning points	Reference page
				Positioner	Pulse train	Program	Network * Option		
SCON-CB/CGB		1	Single phase 230VAC	●	●	—	DeviceNet CC-Link CompoNet EtherCAT EtherNet/IP	512 (768 for network spec.)	Please see P.151
SCON-LC/LCG (*)		1		—	—	●		512 (768 for network spec.)	
SSEL-CS		2	Single phase 115V/230VAC	●	—	●	Note: The type of compatible networks will vary depending on the controller. Please refer to the reference page for more information.	20000	Please see the dedicated controller catalog or manual.
XSEL-P/Q or XSEL-RA/SA (*)		6 or 8 (Depending on the type)	Single phase 230VAC Three-phase 230VAC	—	—	●		20000 or 55000 (Depending on the type)	

(\*) Coming soon

Foreword  
Slider Type  
Wide Slider Type  
Rod Type  
Radial Cylinder  
Wide Radial Cylinder  
Table Type  
Cleanroom Slider  
Cleanroom Wide Slider  
Options  
Reference Data  
Controller

# RCS4-RRR4R

Battery-less Absolute
Motor Unit Coupled
Side-mounted Motor
Body Width 40\* mm
230v AC Servo Motor

Model Specification Items	<b>RCS4</b> — <b>RRR4R</b> — <b>WA</b> — <b>60</b> — [ ] — [ ] — [ ] — <b>T2</b> — [ ] — [ ]	* Body width does not include the width of the side-mounted motor.
	Series — Type — Encoder Type — Motor Type — Lead — Stroke — Applicable Controllers — Cable Length — Options WA: Battery-less Absolute    60: Servo motor 60W    16: 16mm 10: 10mm 5: 5mm 2.5: 2.5mm 60: 60mm 410: 410mm (50mm increments) T2: SCON MSCON SSEL XSEL-P/Q XSEL-RA/SA N: None P: 1m S: 3m M: 5m Refer to Options table below. X□□: Specified Length R□□: Robot Cable	

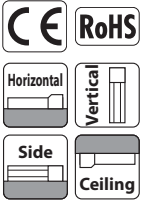

\* Depending on the model, there may be some limitations to using the vertical, side, and ceiling mount positions. Please refer to the Selection Notes on P.138 for more information.

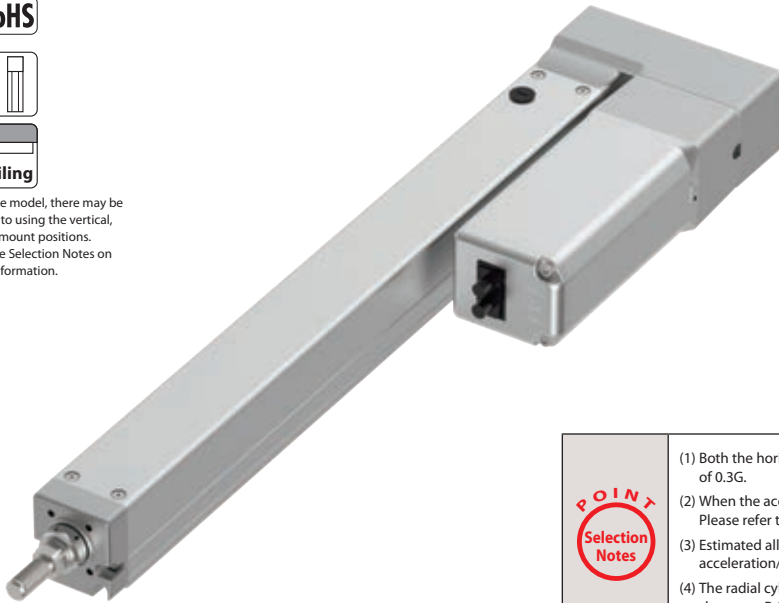

- POINT Selection Notes**
- Both the horizontal and vertical payloads assume operation at an acceleration of 0.3G.
  - When the acceleration is increased, the payload will be reduced. Please refer to "Table of Payload by Acceleration" on P.139 for more details.
  - Estimated allowable duty varies depending on operating conditions (payload, acceleration/deceleration, etc.). Please refer to P. 149 for more information.
  - The radial cylinder is equipped with a built-in guide. Please refer to the graphs shown on P.145 and after for the allowable load mass.

## Actuator Specifications

### Lead and Payload

Model Number	Motor wattage (W)	Lead (mm)	Max. payload		Rated thrust (N)	Stroke (mm)
			Horizontal (kg)	Vertical (kg)		
RCS4-RRR4R-WA-60-16-①-T2-②-③	60	16	8	2	53	60~410 (50mm increments)
RCS4-RRR4R-WA-60-10-①-T2-②-③		10	18	4	85	
RCS4-RRR4R-WA-60-5-①-T2-②-③		5	30	6	170	
RCS4-RRR4R-WA-60-2.5-①-T2-②-③		2.5	40	10	340	

Legend: ① Stroke ② Cable Length ③ Option

### Stroke and Max Speed (Unit: mm/s)

Lead	Stroke (50mm increments)	
	60~410	60~410
16	960	
10	600	
5	300	
2.5	150	

## Cable Length

Type	Cable Code
Standard	P (1m)
	S (3m)
	M (5m)
Specified length (Standard cable)	X06 (6m) ~ X10 (10m)
	X11 (11m) ~ X15 (15m)
	X16 (16m) ~ X20 (20m)
	R01 (1m) ~ R03 (3m)
Robot cable	R04 (4m) ~ R05 (5m)
	R06 (6m) ~ R10 (10m)
	R11 (11m) ~ R15 (15m)
	R16 (16m) ~ R20 (20m)

## Actuator Specifications

Item	Description
Drive system	Ball screw ø8mm, rolled C10
Positioning repeatability	±0.01mm
Lost motion	0.1mm or less
Rod	ø20mm Material: Aluminum with hard alumite treatment
Rod non-rotation precision (*1)	0 degrees
Allowable load and torque on rod tip	Please see P. 68
Rod tip offset/overhang distance	dx/dz: 100mm or less
Ambient operating temp. & humidity	0~40°C, 85% RH or less (Non-condensing)

(\*1) Rod's angular displacement in rotational direction with no load applied to the rod.

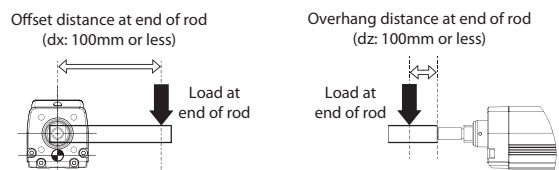

## Options

Name	Option Code	Reference Page
Brake	B	See P.131
Cable exit direction (Top)	CJT	See P.131
Cable exit direction (Bottom)	CJB	See P.131
Cable exit direction (Outside)	CJO	See P.131
Flange (*1)	FL	See P.132
Tip adapter (Flange)	FFA	See P.131
Tip adapter (Keyway)	KFA	See P.134
Tip adapter (Internal thread)	NFA	See P.135
Motor side-mounted to left (standard)	ML	See P.135
Motor side-mounted to right	MR	See P.135
Non-motor end specification	NM	See P.136
Back mounting plate	RP	See P.137

Round cable joint connector with screw locking (*2)	EU	See P.131
---	----	-----------

(\*1) Be sure to confirm with the "Selection Notes (P.138)" when selecting options. (\*2) EU option will be available soon.

## Dimensions

CAD drawings can be downloaded from our website.  
www.robocylinder.de

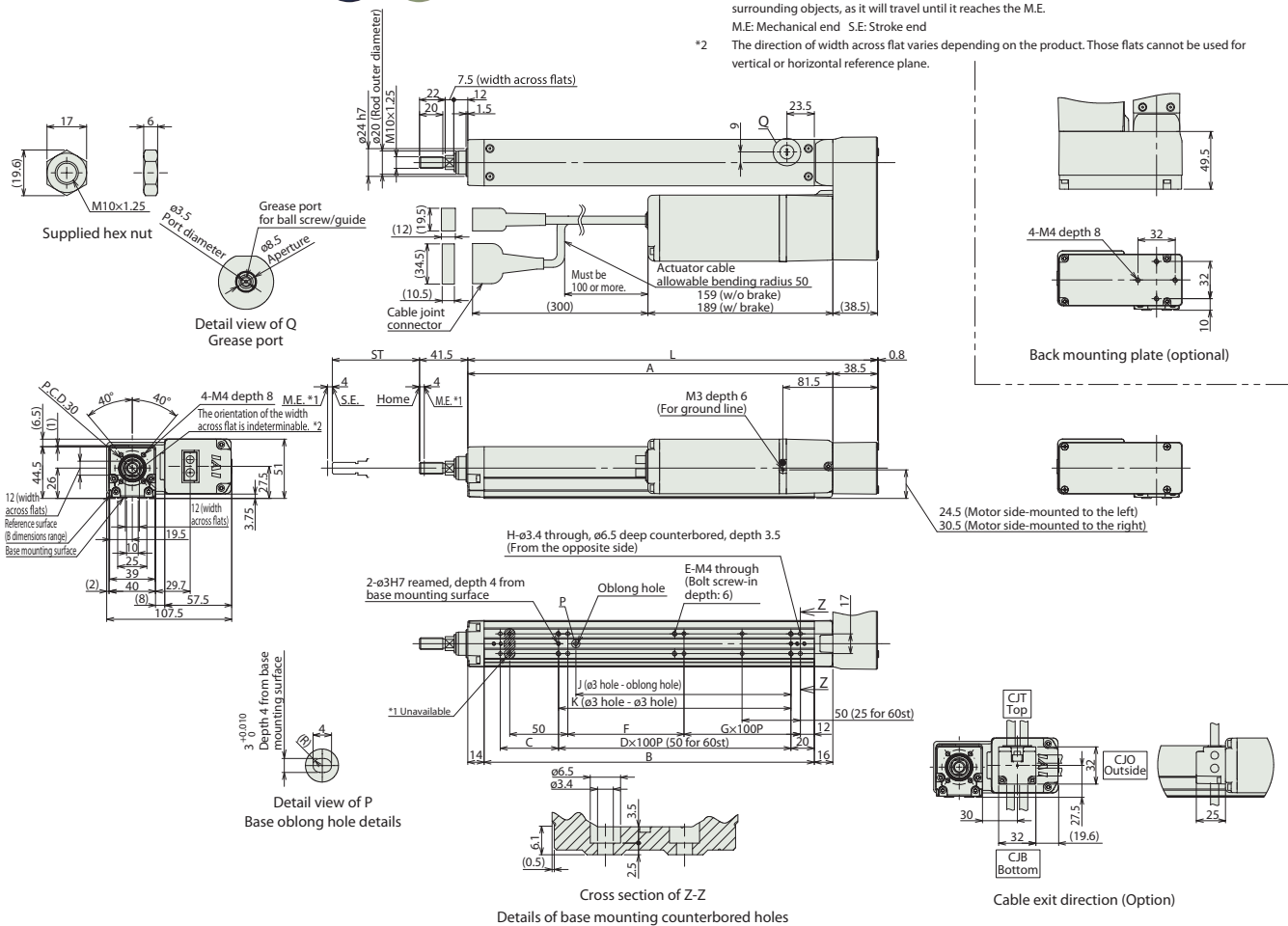

## Dimensions and Mass by Stroke

Stroke	60	110	160	210	260	310	360	410
L	202.5	252.5	302.5	352.5	402.5	452.5	502.5	552.5
A	164	214	264	314	364	414	464	514
B	134	184	234	284	334	384	434	484
C	50	50	100	50	100	50	100	50
D	0	1	1	2	2	3	3	4
E	6	6	6	8	8	10	10	12
F	50	100	50	100	50	100	50	100
G	0	0	1	1	2	2	3	3
H (*)	6	6	8	8	10	10	12	12
J	35	85	85	185	185	285	285	385
K	50	100	100	200	200	300	300	400
Allowable static load on rod tip (N)	63.4	50.7	42.1	36.0	31.3	27.6	24.6	22.2
Allowable dynamic load on rod tip (5000km life) (N)	28.9	22.2	17.9	14.8	12.6	10.8	9.4	8.2
Allowable static torque on rod tip (N-m)	17.9	15.5	13.4	11.6	10.2	9.0	8.0	7.1
Allowable dynamic torque on rod tip (N-m)	6.4	5.1	4.3	3.7	3.2	2.9	2.6	2.3
Mass (kg)								
W/o brake	1.6	1.7	1.8	2.0	2.1	2.2	2.3	2.5
W/ brake	1.9	2.0	2.1	2.3	2.4	2.5	2.6	2.8

(\*) Does not include holes that are not available.

## Rod Deflection of RCS4-RRA4R (Reference Values)

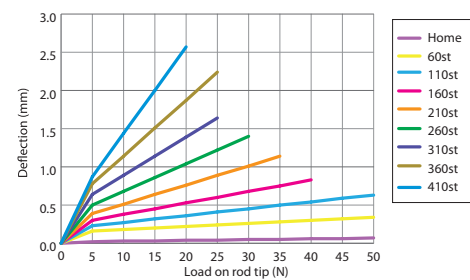

## Applicable Controllers

The RCS4 series actuators can be operated by the controllers indicated below. Please select the type depending on your intended use.

Name	External view	Max. number of connectable axes	Input power	Control method				Maximum number of positioning points	Reference page	
				Positioner	Pulse train	Program	Network * Option			
SCON-CB/CGB		1	Single phase 115V/230VAC	●	●	—	DeviceNet CCLink CompoNet	512 (768 for network spec.)	Please see the dedicated controller catalog or manual.	
SCON-LC/LCG (*)		1		—	—	●		EtherCAT EtherNet/IP		512 (768 for network spec.)
SCON-CAL/CGAL		1		●	—	—				256
MSCON-C		6		This model is network-compatible only.				20000		
SSEL-CS		2		●	—	●	20000 or 55000 (Depending on the type)			
XSEL-P/Q or XSEL-RA/SA (*)		6 or 8 (Depending on the type)		Single phase 230VAC Three-phase 230VAC	—	—	●			

(\*) Coming soon

Foreword  
Slider Type  
Wide Slider Type  
Rod Type  
Radial Cylinder®  
Wide Radial Cylinder  
Table Type  
Cleanroom Slider  
Cleanroom Wide Slider  
Options  
Reference Data  
Controller

# RCS4-RAA6R

Battery-less Absolute

Motor Unit Coupled

Side-mounted Motor

Body Width 60\* mm

230v AC Servo Motor

<b>Model Specification Items</b>	<b>RCS4</b> — <b>RRA6R</b> — <b>WA</b> — <b>100</b> — <span style="border: 1px solid black; display: inline-block; width: 15px; height: 15px;"></span> — <span style="border: 1px solid black; display: inline-block; width: 15px; height: 15px;"></span> — <b>T2</b> — <span style="border: 1px solid black; display: inline-block; width: 15px; height: 15px;"></span> — <span style="border: 1px solid black; display: inline-block; width: 15px; height: 15px;"></span>									* Body width does not include the width of the side-mounted motor.
	Series — Type — Encoder Type — Motor Type — Lead — Stroke — Applicable Controllers — Cable Length — Options	WA: Battery-less Absolute	100: Servo motor 100W	20:20mm 12:12mm 6: 6mm 3: 3mm	65:65mm 415:415mm (50mm increments)	T2:SCON MSCON SSEL XSEL-P/Q XSEL-RA/SA	N : None P : 1m S : 3m M : 5m	Refer to Options table below.	X□□ : Specified Length R□□ : Robot Cable	

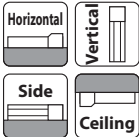

\* Depending on the model, there may be some limitations to using the vertical, side, and ceiling mount positions. Please refer to the Selection Notes on P.138 for more information.



- (1) Both the horizontal and vertical payloads assume operation at an acceleration of 0.3G.
- (2) When the acceleration is increased, the payload will be reduced. Please refer to "Table of Payload by Acceleration" on P.139 for more details.
- (3) Estimated allowable duty varies depending on operating conditions (payload, acceleration/deceleration, etc.). Please refer to P. 149 for more information.
- (4) The radial cylinder is equipped with a built-in guide. Please refer to the graphs shown on P.145 and after for the allowable load mass.

### Actuator Specifications

#### Lead and Payload

Model Number	Motor wattage (W)	Lead (mm)	Max. payload		Rated thrust (N)	Stroke (mm)
			Horizontal (kg)	Vertical (kg)		
RCS4-RRA6R-WA-100-20-①-T2-②-③	100	20	15	4	85	65~415 (50mm increments)
RCS4-RRA6R-WA-100-12-①-T2-②-③		12	25	9	142	
RCS4-RRA6R-WA-100-6-①-T2-②-③		6	50	19	283	
RCS4-RRA6R-WA-100-3-①-T2-②-③		3	60	20	566	

Legend: ① Stroke ② Cable Length ③ Option

#### Stroke and Max Speed (Unit: mm/s)

Lead	Stroke	
	Stroke (50mm increments)	65~415 (50mm increments)
20	1200	
12	720	
6	360	
3	180	

### Cable Length

Type	Cable Code
Standard	<b>P</b> (1m)
	<b>S</b> (3m)
	<b>M</b> (5m)
Specified length (Standard cable)	<b>X06</b> (6m) ~ <b>X10</b> (10m)
	<b>X11</b> (11m) ~ <b>X15</b> (15m)
	<b>X16</b> (16m) ~ <b>X20</b> (20m)
	<b>R01</b> (1m) ~ <b>R03</b> (3m)
Robot cable	<b>R04</b> (4m) ~ <b>R05</b> (5m)
	<b>R06</b> (6m) ~ <b>R10</b> (10m)
	<b>R11</b> (11m) ~ <b>R15</b> (15m)
	<b>R16</b> (16m) ~ <b>R20</b> (20m)

### Actuator Specifications

Item	Description
Drive system	Ball screw ø10mm, rolled C10
Positioning repeatability	±0.01mm
Lost motion	0.1mm or less
Rod	ø25mm Material: Aluminum with hard alumite treatment
Rod non-rotation precision (*1)	0 degrees
Allowable load and torque on rod tip	Please see P. 70
Rod tip offset/overhang distance	dx/dz: 100mm or less
Ambient operating temp. & humidity	0~40°C, 85% RH or less (Non-condensing)

(\*1) Rod's angular displacement in rotational direction with no load applied to the rod.

Offset distance at end of rod (dx: 100mm or less)

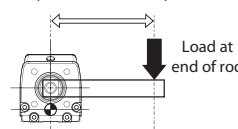

Overhang distance at end of rod (dz: 100mm or less)

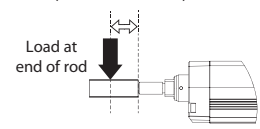

### Options

Name	Option Code	Reference Page
Brake	<b>B</b>	See P.131
Cable exit direction (Top)	<b>CJT</b>	See P.131
Cable exit direction (Bottom)	<b>CJB</b>	See P.131
Cable exit direction (Outside)	<b>CJO</b>	See P.131
Flange (*1)	<b>FL</b>	See P.132
Tip adapter (Flange)	<b>FFA</b>	See P.131
Tip adapter (Keyway)	<b>KFA</b>	See P.134
Tip adapter (Internal thread)	<b>NFA</b>	See P.135
Motor side-mounted to left (standard)	<b>ML</b>	See P.135
Motor side-mounted to right	<b>MR</b>	See P.135
Non-motor end specification	<b>NM</b>	See P.136

Round cable joint connector with screw locking (*2)	<b>EU</b>	See P.131
---	-----------	-----------

(\*1) Be sure to confirm with the "Selection Notes (P.138)" when selecting options. (\*2) EU option will be available soon.



# RCS4-RAA7R

Battery-less Absolute
Motor Unit Coupled
Side-mounted Motor
Body Width 70\* mm
230v AC Servo Motor

Model Specification Items	<b>RCS4</b> — <b>RAA7R</b> — <b>WA</b> — <b>200</b> — [ ] — [ ] — [ ] — <b>T2</b> — [ ] — [ ]	* Body width does not include the width of the side-mounted motor.
	Series — Type — Encoder Type — Motor Type — Lead — Stroke — Applicable Controllers — Cable Length — Options WA: Battery-less Absolute    200: Servo motor 200W    24:24mm 16:16mm 8: 8mm 4: 4mm    70:70mm 520:520mm (50mm increments)    T2:SCON MSCON SSEL XSEL-P/Q XSEL-RA/SA    N : None P : 1m S : 3m M : 5m    Refer to Options table below.    X□□ : Specified Length R□□ : Robot Cable	



\* Depending on the model, there may be some limitations to using the vertical, side, and ceiling mount positions. Please refer to the Selection Notes on P.138 for more information.

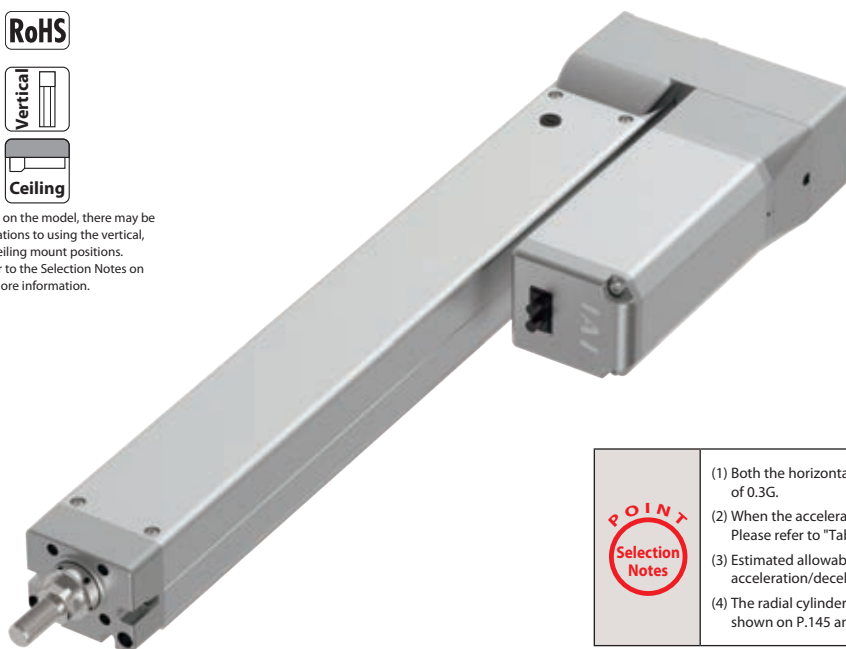

**POINT Selection Notes**

- Both the horizontal and vertical payloads assume operation at an acceleration of 0.3G.
- When the acceleration is increased, the payload will be reduced. Please refer to "Table of Payload by Acceleration" on P.139 for more details.
- Estimated allowable duty varies depending on operating conditions (payload, acceleration/deceleration, etc.). Please refer to P. 149 for more information.
- The radial cylinder is equipped with a built-in guide. Please refer to the graphs shown on P.145 and after for the allowable load mass.

## Actuator Specifications

### Lead and Payload

Model Number	Motor wattage (W)	Lead (mm)	Max. payload		Rated thrust (N)	Stroke (mm)
			Horizontal (kg)	Vertical (kg)		
RCS4-RAA7R-WA-200-24-①-T2-②-③	200	24	20	6	142	70~520 (50mm increments)
RCS4-RAA7R-WA-200-16-①-T2-②-③		16	45	12	214	
RCS4-RAA7R-WA-200-8-①-T2-②-③		8	60	25	427	
RCS4-RAA7R-WA-200-4-①-T2-②-③		4	80	35	855	

Legend: ① Stroke ② Cable Length ③ Option

### Stroke and Max Speed (Unit: mm/s)

Lead	Stroke	70~520 (50mm increments)
	24	
16		960
8		480
4		240

## Cable Length

Type	Cable Code
Standard	<b>P</b> (1m)
	<b>S</b> (3m)
	<b>M</b> (5m)
Specified length (Standard cable)	<b>X06</b> (6m) ~ <b>X10</b> (10m)
	<b>X11</b> (11m) ~ <b>X15</b> (15m)
	<b>X16</b> (16m) ~ <b>X20</b> (20m)
	<b>R01</b> (1m) ~ <b>R03</b> (3m)
	<b>R04</b> (4m) ~ <b>R05</b> (5m)
Robot cable	<b>R06</b> (6m) ~ <b>R10</b> (10m)
	<b>R11</b> (11m) ~ <b>R15</b> (15m)
	<b>R16</b> (16m) ~ <b>R20</b> (20m)

## Actuator Specifications

Item	Description
Drive system	Ball screw ø12mm, rolled C10
Positioning repeatability	±0.01mm
Lost motion	0.1mm or less
Rod	ø30mm Material: Aluminum with hard alumite treatment
Rod non-rotation precision (*1)	0 degrees
Allowable load and torque on rod tip	Please see P. 72
Rod tip offset/overhang distance	dx/dz: 150mm or less
Ambient operating temp. & humidity	0~40°C, 85% RH or less (Non-condensing)

(\*1) Rod's angular displacement in rotational direction with no load applied to the rod.

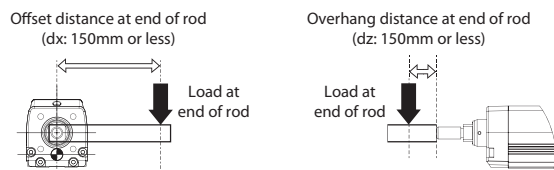

## Options

Name	Option Code	Reference Page
Brake	<b>B</b>	See P.131
Cable exit direction (Top)	<b>CJT</b>	See P.131
Cable exit direction (Bottom)	<b>CJB</b>	See P.131
Cable exit direction (Outside)	<b>CJO</b>	See P.131
Flange (*1)	<b>FL</b>	See P.132
Tip adapter (Flange)	<b>FFA</b>	See P.131
Tip adapter (Keyway)	<b>KFA</b>	See P.134
Tip adapter (Internal thread)	<b>NFA</b>	See P.135
Motor side-mounted to left (standard)	<b>ML</b>	See P.135
Motor side-mounted to right	<b>MR</b>	See P.135
Non-motor end specification	<b>NM</b>	See P.136

Round cable joint connector with screw locking (*2)	<b>EU</b>	See P.131
---	-----------	-----------

(\*1) Be sure to confirm with the "Selection Notes (P.138)" when selecting options. (\*2) EU option will be available soon.





# RCS4-RRR8R

Battery-less Absolute
Motor Unit Coupled
Side-mounted Motor
Body Width 90\* mm
230v AC Servo Motor

Model Specification Items	<b>RCS4</b> — <b>RRR8R</b> — <b>WA</b> — <b>400</b> — [ ] — [ ] — [ ] — [ ] — [ ] — [ ]	* Body width does not include the width of the side-mounted motor.
	Series — Type — Encoder Type — Motor Type — Lead — Stroke — Applicable Controllers — Cable Length — Options WA: Battery-less Absolute    400: Servo motor 400W    30:30mm 20:20mm 10:10mm 5: 5mm    50:50mm 700:700mm (50mm increments)    T2:SCON SSEL XSEL-P/Q XSEL-RA/SA    N : None P : 1m S : 3m M : 5m    Refer to Options table below.	

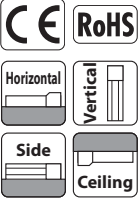

\* Depending on the model, there may be some limitations to using the vertical, side, and ceiling mount positions. Please refer to the Selection Notes on P.138 for more information.

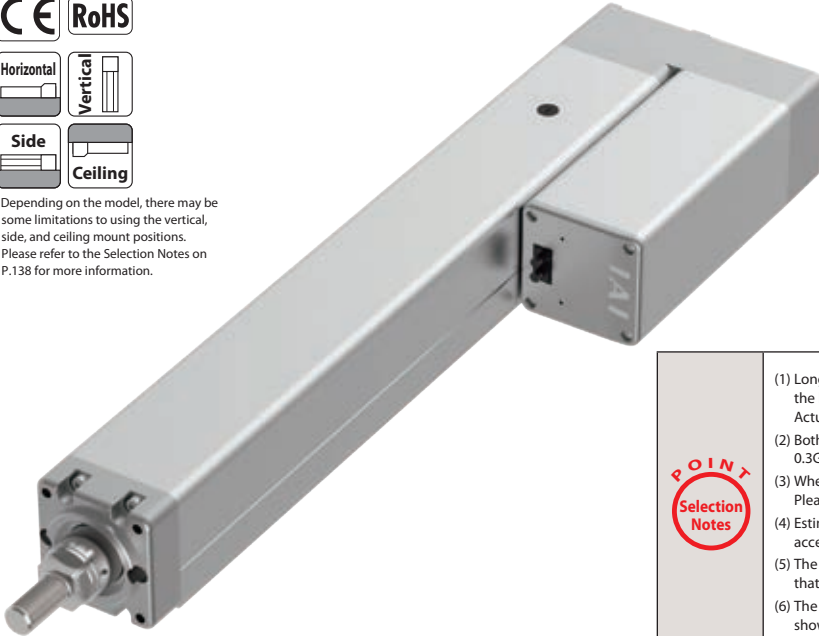

- (1) Longer strokes may cause the maximum speed to decrease due to resonance of the ball screw. Be sure to check the maximum speed of the desired stroke in the Actuator Specifications table, which can be found below
- (2) Both the horizontal and vertical payloads assume operation at an acceleration of 0.3G. (0.2G for lead 5).
- (3) When the acceleration is increased, the payload will be reduced. Please refer to "Table of Payload by Acceleration" on P.139 for more details.
- (4) Estimated allowable duty varies depending on operating conditions (payload, acceleration/deceleration, etc.). Please refer to P. 149 for more information.
- (5) The value of the maximum payload assumes that there is an external guide and that the rod is not subjected to external force other than in the moving direction.
- (6) The radial cylinder is equipped with a built-in guide. Please refer to the graphs shown on P.145 and after for the allowable load mass.

## Actuator Specifications

### Lead and Payload

Model Number	Motor wattage (W)	Lead (mm)	Max. payload		Rated thrust (N)	Stroke (mm)
			Horizontal (kg)	Vertical (kg)		
RCS4-RRR8R-WA-400-30-①-T2-②-③	400	30	30	8	226	50~700 (50mm increments)
RCS4-RRR8R-WA-400-20-①-T2-②-③		20	60	17	339	
RCS4-RRR8R-WA-400-10-①-T2-②-③		10	80	34	678	
RCS4-RRR8R-WA-400-5-①-T2-②-③		5	100	72	1357	

Legend: ① Stroke ② Cable Length ③ Option

### Stroke and Max Speed

(Unit: mm/s)

Stroke / Lead	Stroke (mm)									
	50~250 (50mm increments)	300	350	400	450	500	550	600	650	700
30	1300	1230	970	790	650	540	460	400	350	
20	1000	820	650	520	430	360	310	260	230	
10	550	520	400	310	250	210	180	150	130	110
5	275	250	190	150	120	100	80	70	60	55

## Cable Length

Type	Cable Code
Standard	P (1m)
	S (3m)
	M (5m)
Specified length (Standard cable)	X06 (6m) ~ X10 (10m)
	X11 (11m) ~ X15 (15m)
	X16 (16m) ~ X20 (20m)
	R01 (1m) ~ R03 (3m)
Robot cable	R04 (4m) ~ R05 (5m)
	R06 (6m) ~ R10 (10m)
	R11 (11m) ~ R15 (15m)
	R16 (16m) ~ R20 (20m)

## Actuator Specifications

Item	Description
Drive system	Ball screw ø16mm, rolled C10
Positioning repeatability	±0.01mm
Lost motion	0.1mm or less
Rod	ø40mm Material: Aluminum with hard alumite treatment
Rod non-rotation precision (*1)	0 degrees
Allowable load and torque on rod tip	Please see P. 74
Rod tip offset/overhang distance	dx/dz: 150mm or less
Ambient operating temp. & humidity	0~40°C, 85% RH or less (Non-condensing)

(\*1) Rod's angular displacement in rotational direction with no load applied to the rod.

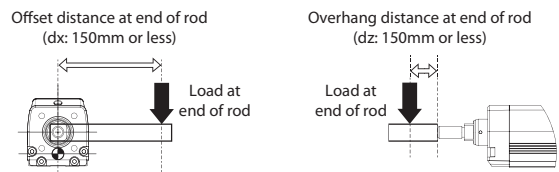

## Options

Name	Option Code	Reference Page
Brake	B	See P.131
Cable exit direction (Top)	CJT	See P.131
Cable exit direction (Bottom)	CJB	See P.131
Cable exit direction (Outside)	CJO	See P.131
Flange (*1)	FL	See P.132
Tip adapter (Internal thread)	NFA	See P.135
Motor side-mounted to left (standard)	ML	See P.135
Motor side-mounted to right	MR	See P.135
Non-motor end specification	NM	See P.136

Round cable joint connector with screw locking (*2)	EU	See P.131
---	----	-----------

(\*1) Be sure to confirm with the "Selection Notes (P.138)" when selecting options. (\*2) EU option will be available soon.

## Dimensions

CAD drawings can be downloaded from our website.

[www.robocylinder.de](http://www.robocylinder.de)



\*1 When the rod is returning to its home position, please be careful of interference from surrounding objects, as it will travel until it reaches the M.E.

M.E: Mechanical end S.E: Stroke end

\*2 The direction of width across flat varies depending on the product. Those flats cannot be used for vertical or horizontal reference plane.

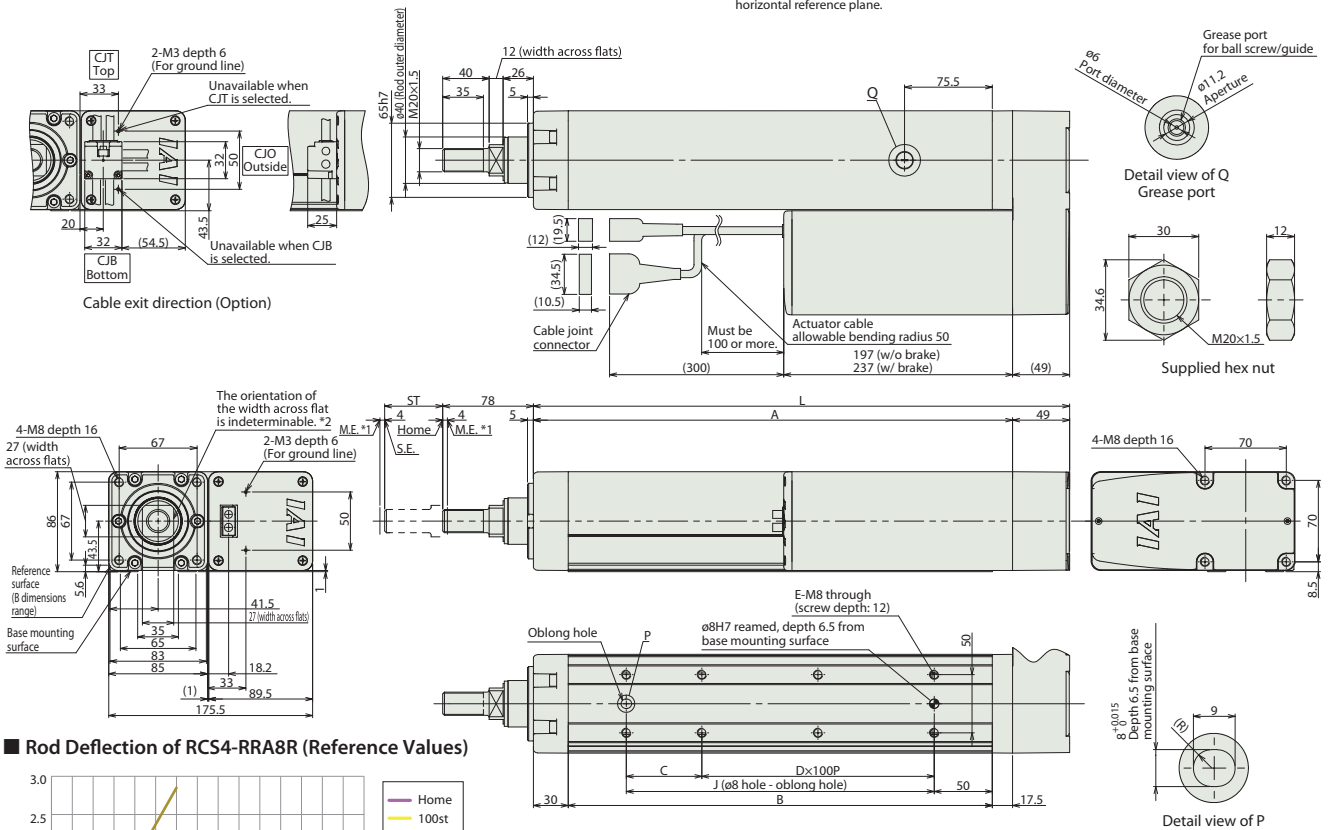

## Applicable Controllers

The RCS4 series actuators can be operated by the controllers indicated below. Please select the type depending on your intended use.

Name	External view	Max. number of connectable axes	Input power	Control method				Maximum number of positioning points	Reference page
				Positioner	Pulse train	Program	Network * Option		
SCON-CB/CGB		1	Single phase 230VAC	●	●	-	DeviceNet CC-Link CompoNet EtherCAT EtherNet/IP	512 (768 for network spec.)	Please see P.151
SCON-LC/LCG (*)		1		-	-	●		512 (768 for network spec.)	
SSEL-CS		2	Single phase 115V/230VAC	●	-	●	Note: The type of compatible networks will vary depending on the controller. Please refer to the reference page for more information.	20000	Please see the dedicated controller catalog or manual.
XSEL-P/Q or XSEL-RA/SA (*)		6 or 8 (Depending on the type)	Single phase 230VAC Three-phase 230VAC	-	-	●		20000 or 55000 (Depending on the type)	

(\*) Coming soon

Foreword  
Slider Type  
Wide Slider Type  
Rod Type  
Radial Cylinder  
Wide Radial Cylinder  
Table Type  
Cleanroom Slider  
Cleanroom Wide Slider  
Options  
Reference Data  
Controller

# RCS4-WRA10C

Battery-less Absolute
Motor Unit Coupled
Straight Motor
Body Width 100 mm
230v AC Servo Motor

Model Specification Items	<b>RCS4</b> — <b>WRA10C</b> — <b>WA</b> — <b>60</b> — [ ] — [ ] — <b>T2</b> — [ ] — [ ]							
Series	Type	Encoder Type	Motor Type	Lead	Stroke	Applicable Controllers	Cable Length	Options
		WA: Battery-less Absolute	60: Servo motor 60W	16: 16mm 10: 10mm 5: 5mm 2.5: 2.5mm	50: 50mm 500: 500mm (50mm increments)	T2: SCON MSCON SSEL XSEL-P/Q XSEL-RA/SA	N: None P: 1m S: 3m M: 5m X [ ] : Specified Length R [ ] : Robot Cable	Refer to Options table below. * Be sure to select a direction for the cable exit direction.

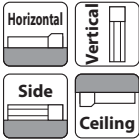

\* Depending on the model, there may be some limitations to using the vertical, side, and ceiling mount positions. Please refer to the Selection Notes on P.138 for more information.

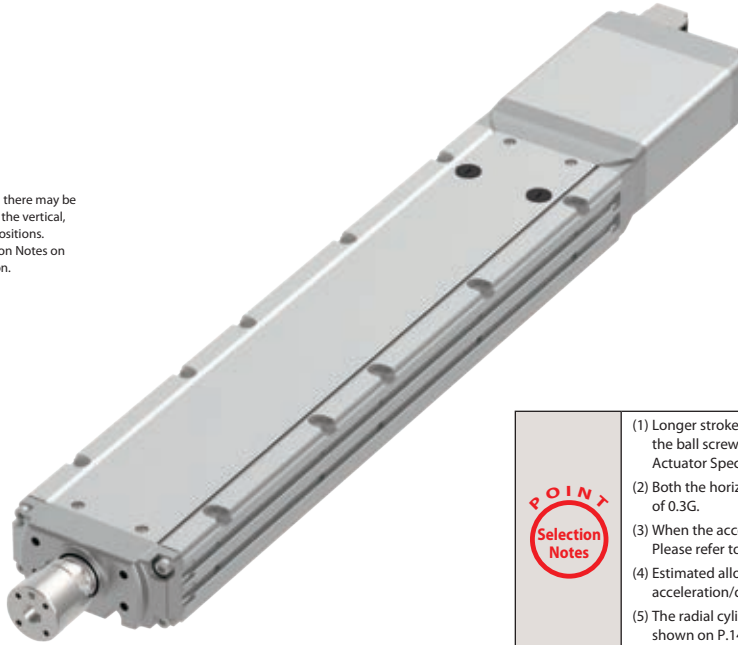

- POINT Selection Notes**
- Longer strokes may cause the maximum speed to decrease due to resonance of the ball screw. Be sure to check the maximum speed of the desired stroke in the Actuator Specifications table, which can be found below.
  - Both the horizontal and vertical payloads assume operation at an acceleration of 0.3G.
  - When the acceleration is increased, the payload will be reduced. Please refer to "Table of Payload by Acceleration" on P.139 for more details.
  - Estimated allowable duty varies depending on operating conditions (payload, acceleration/deceleration, etc.). Please refer to P. 149 for more information.
  - The radial cylinder is equipped with a built-in guide. Please refer to the graphs shown on P.147 and after for the allowable load mass.

## Actuator Specifications

### Lead and Payload

Model Number	Motor wattage (W)	Lead (mm)	Max. payload		Rated thrust (N)	Stroke (mm)
			Horizontal (kg)	Vertical (kg)		
RCS4-WRA10C-WA-60-16-①-T2-②-③	60	16	5	-	53	50~500 (50mm increments)
RCS4-WRA10C-WA-60-10-①-T2-②-③		10	16	3	85	
RCS4-WRA10C-WA-60-5-①-T2-②-③		5	25	5	170	
RCS4-WRA10C-WA-60-2.5-①-T2-②-③		2.5	40	10	340	

Legend: ① Stroke ② Cable Length ③ Option

### Stroke and Max Speed

Lead	Stroke	(Unit: mm/s)		
		50~400 (50mm increments)	450 (mm)	500 (mm)
16		800		770
10		600	580	490
5		300	290	240
2.5		150	145	120

## Cable Length

Type	Cable Code
Standard	P (1m)
	S (3m)
	M (5m)
Specified length (Standard cable)	X06 (6m) ~ X10 (10m)
	X11 (11m) ~ X15 (15m)
	X16 (16m) ~ X20 (20m)
	R01 (1m) ~ R03 (3m)
Robot cable	R04 (4m) ~ R05 (5m)
	R06 (6m) ~ R10 (10m)
	R11 (11m) ~ R15 (15m)
	R16 (16m) ~ R20 (20m)

## Actuator Specifications

Item	Description
Drive system	Ball screw ø8mm, rolled C10
Positioning repeatability	±0.01mm
Lost motion	0.1mm or less
Rod	ø25mm Stainless steel
Rod non-rotation precision (*1)	0 degrees
Allowable load and torque on rod tip	Please see P. 76
Rod tip offset/overhang distance	dx/dz: 100mm or less
Ambient operating temp. & humidity	0~40°C, 85% RH or less (Non-condensing)

(\*1) Rod's angular displacement in rotational direction with no load applied to the rod.

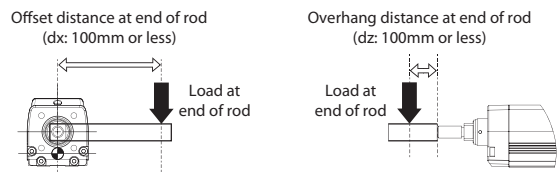

## Options

Name	Option Code	Reference Page
Brake	B	See P.131
Cable exit direction (Top)	CJT	See P.131
Cable exit direction (Right)	CJR	See P.131
Cable exit direction (Left)	CJL	See P.131
Cable exit direction (Bottom)	CJB	See P.131
Flange	FL	See P.132
Non-motor end specification	NM	See P.136
T-slot nut bar (Left)	NTBL	See P.136
T-slot nut bar (Right)	NTBR	See P.136

(\*1) EU option will be available soon.

Round cable joint connector with screw locking (*1)	EU	See P.131
---	----	-----------



# RCS4-WRA12C

Battery-less Absolute
Motor Unit Coupled
Straight Motor
Body Width 120 mm
230v AC Servo Motor

Model Specification Items	<b>RCS4</b> — <b>WRA12C</b> — <b>WA</b> — <b>100</b> — <input type="checkbox"/> — <input type="checkbox"/> — <input type="checkbox"/>	<b>T2</b> — <input type="checkbox"/> — <input type="checkbox"/>
	Series — Type — Encoder Type — Motor Type — Lead — Stroke — Applicable Controllers — Cable Length — Options	
	WA: Battery-less Absolute 100: Servo motor 100W	20:20mm 12:12mm 6: 6mm 3: 3mm
	50:50mm 500:500mm (50mm increments)	T2:SCON MSCON SSEL XSEL-P/Q XSEL-RA/SA
		N : None P : 1m S : 3m M : 5m X□□ : Specified Length R□□ : Robot Cable
		Refer to Options table below. * Be sure to select a direction for the cable exit direction.

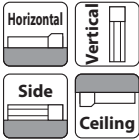

\* Depending on the model, there may be some limitations to using the vertical, side, and ceiling mount positions. Please refer to the Selection Notes on P.138 for more information.

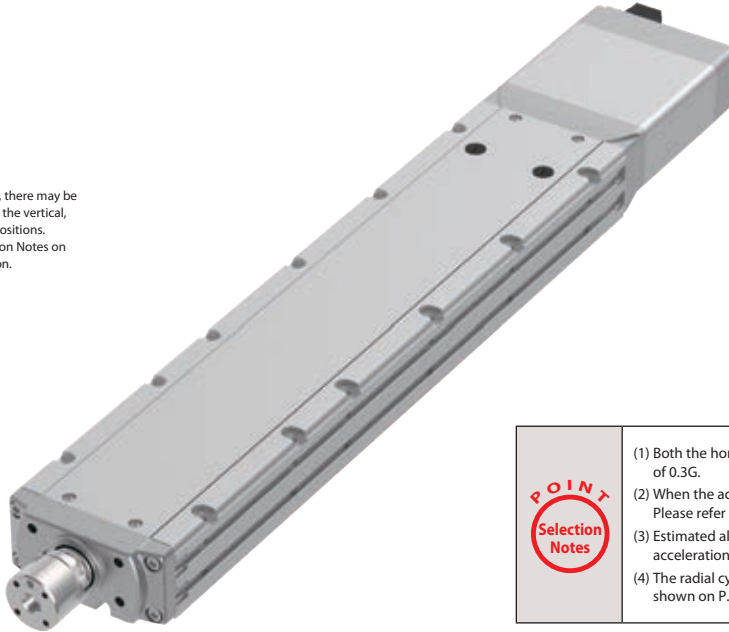

**POINT Selection Notes**

- Both the horizontal and vertical payloads assume operation at an acceleration of 0.3G.
- When the acceleration is increased, the payload will be reduced. Please refer to "Table of Payload by Acceleration" on P.139 for more details.
- Estimated allowable duty varies depending on operating conditions (payload, acceleration/deceleration, etc.). Please refer to P. 149 for more information.
- The radial cylinder is equipped with a built-in guide. Please refer to the graphs shown on P.147 and after for the allowable load mass.

## Actuator Specifications

### Lead and Payload

Model Number	Motor wattage (W)	Lead (mm)	Max. payload		Rated thrust (N)	Stroke (mm)
			Horizontal (kg)	Vertical (kg)		
RCS4-WRA12C-WA-100-20-①-T2-②-③	100	20	12	2	85	50~500 (50mm increments)
RCS4-WRA12C-WA-100-12-①-T2-②-③		12	25	6	142	
RCS4-WRA12C-WA-100-6-①-T2-②-③		6	40	15	283	
RCS4-WRA12C-WA-100-3-①-T2-②-③		3	60	20	566	

Legend: ① Stroke ② Cable Length ③ Option

### Stroke and Max Speed (Unit: mm/s)

Lead	Stroke	
	50~500 (50mm increments)	
20	1000	
12	720	
6	360	
3	180	

## Cable Length

Type	Cable Code
Standard	P (1m)
	S (3m)
	M (5m)
Specified length (Standard cable)	X06 (6m) ~ X10 (10m)
	X11 (11m) ~ X15 (15m)
	X16 (16m) ~ X20 (20m)
	R01 (1m) ~ R03 (3m)
Robot cable	R04 (4m) ~ R05 (5m)
	R06 (6m) ~ R10 (10m)
	R11 (11m) ~ R15 (15m)
	R16 (16m) ~ R20 (20m)

## Options

Name	Option Code	Reference Page
Brake	B	See P.131
Cable exit direction (Top)	CJT	See P.131
Cable exit direction (Right)	CJR	See P.131
Cable exit direction (Left)	CJL	See P.131
Cable exit direction (Bottom)	CJB	See P.131
Flange	FL	See P.132
Non-motor end specification	NM	See P.136
T-slot nut bar (Left)	NTBL	See P.136
T-slot nut bar (Right)	NTBR	See P.136

(\*1) EU option will be available soon.

## Actuator Specifications

Item	Description
Drive system	Ball screw ø10mm, rolled C10
Positioning repeatability	±0.01mm
Lost motion	0.1mm or less
Rod	ø30mm Stainless steel
Rod non-rotation precision (*1)	0 degrees
Allowable load and torque on rod tip	Please see P. 78
Rod tip offset/overhang distance	dx/dz: 100mm or less
Ambient operating temp. & humidity	0~40°C, 85% RH or less (Non-condensing)

(\*1) Rod's angular displacement in rotational direction with no load applied to the rod.

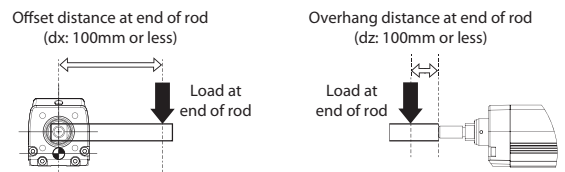

Round cable joint connector with screw locking (*1)	EU	See P.131
---	----	-----------

## Dimensions

CAD drawings can be downloaded from our website.  
www.robocylinder.de



\*1 When the rod is returning to its home position, please be careful of interference from surrounding objects, as it will travel until it reaches the M.E.  
M.E: Mechanical end S.E: Stroke end

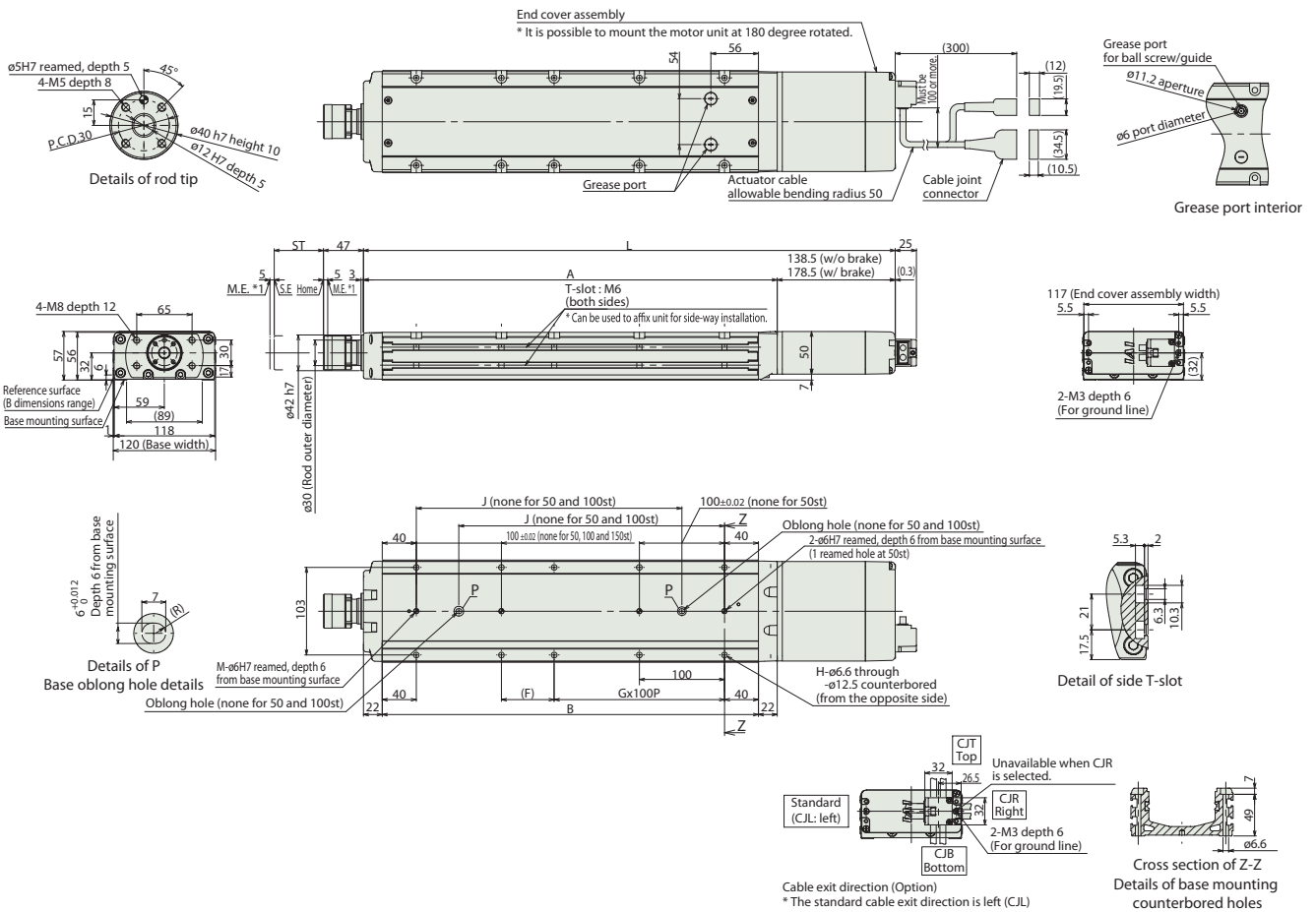

## Dimensions and Mass by Stroke

L	ST		50	100	150	200	250	300	350	400	450	500
		W/o brake	374.5	424.5	474.5	524.5	574.5	624.5	674.5	724.5	774.5	824.5
	W/ brake	414.5	464.5	514.5	564.5	614.5	664.5	714.5	764.5	814.5	864.5	
A		236	286	336	386	436	486	536	586	636	686	
B		192	242	292	342	392	442	492	542	592	642	
F		112	62	112	62	112	62	112	62	112	62	
G		0	1	1	1	1	2	2	3	3	4	
H		4	6	6	8	8	10	10	12	12	14	
J		-	-	162	212	262	312	362	412	462	512	
M		1	1	1	2	2	2	2	2	2	2	
Allowable static load on rod tip (N)		294	294	294	294	294	269	241	218	198	181	
Allowable static torque on rod tip (N-m)		20	20	20	20	20	20	20	20	20	20	
3000km	Allowable load on rod tip (N)	147	147	137	121	107	96	87	79	72	65	
	Load offset 0mm	100	100	100	100	99	90	82	75	68	63	
5000km	Allowable dynamic torque on rod tip (N-m)	10.0	10.0	10.0	10.0	9.9	9.0	8.2	7.5	6.8	6.3	
	Allowable load on rod tip (N)	147	133	115	101	90	80	72	65	59	54	
Allowable dynamic torque on rod tip (N-m)		10.0	10.0	10.0	9.2	8.3	7.5	6.8	6.2	5.6	5.1	
Mass (kg)	W/o brake	4.8	5.5	6.1	6.8	7.4	8.1	8.7	9.4	10.0	10.7	
	W/ brake	5.1	5.8	6.4	7.1	7.7	8.4	9.0	9.7	10.3	11.0	

## Rod Deflection of RCS4-WRA12C (Reference Values)

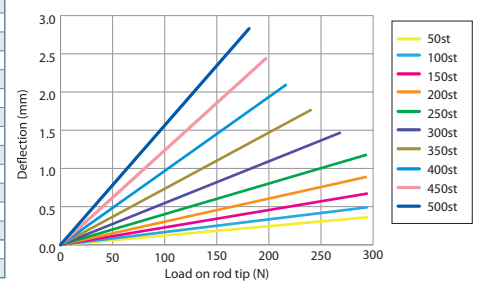

## Applicable Controllers

The RCS4 series actuators can be operated by the controllers indicated below. Please select the type depending on your intended use.

Name	External view	Max. number of connectable axes	Input power	Control method				Maximum number of positioning points	Reference page	
				Positioner	Pulse train	Program	Network * Option			
SCON-CB/CGB		1	Single phase 115V/230VAC	●	●	-	DeviceNet CCLink CC-Link CompoNet EtherCAT EtherNet/IP	512 (768 for network spec.)	Please see P.151	
SCON-LC/LCG (*)		1		-	-	●		512 (768 for network spec.)		
SCON-CAL/CGAL		1		●	-	-		512 (768 for network spec.)		
MSCON-C		6		This model is network-compatible only.				256		
SSEL-CS		2		●	-	●		20000		
XSEL-P/Q or XSEL-RA/SA (*)		6 or 8 (Depending on the type)	Single phase 230VAC Three-phase 230VAC	-	-	●	20000 or 55000 (Depending on the type)	Please see the dedicated controller catalog or manual.		
Note: The type of compatible networks will vary depending on the controller. Please refer to the reference page for more information.										

(\*) Coming soon

# RCS4-WRA14C

Battery-less Absolute
Motor Unit Coupled
Straight Motor
Body Width 140 mm
230v AC Servo Motor

Model Specification Items	<b>RCS4</b> — <b>WRA14C</b> — <b>WA</b> — <b>200</b> — [ ] — [ ] — [ ] — <b>T2</b> — [ ] — [ ]							
Series	Type	Encoder Type	Motor Type	Lead	Stroke	Applicable Controllers	Cable Length	Options
		WA: Battery-less Absolute	200: Servo motor 200W	24:24mm 16:16mm 8: 8mm 4: 4mm	50:50mm + 600:600mm (50mm increments)	T2:SCON MSCON SSEL XSEL-P/Q XSEL-RA/SA	N : None P : 1m S : 3m M : 5m X [ ] : Specified Length R [ ] : Robot Cable	Refer to Options table below. * Be sure to select a direction for the cable exit direction.

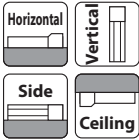

\* Depending on the model, there may be some limitations to using the vertical, side, and ceiling mount positions. Please refer to the Selection Notes on P.138 for more information.

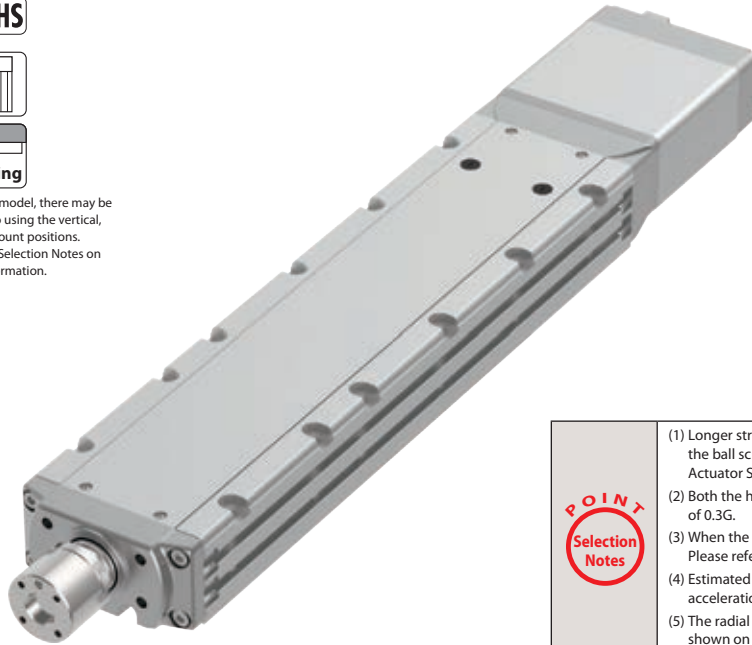

**POINT Selection Notes**

- Longer strokes may cause the maximum speed to decrease due to resonance of the ball screw. Be sure to check the maximum speed of the desired stroke in the Actuator Specifications table, which can be found below.
- Both the horizontal and vertical payloads assume operation at an acceleration of 0.3G.
- When the acceleration is increased, the payload will be reduced. Please refer to "Table of Payload by Acceleration" on P.139 for more details.
- Estimated allowable duty varies depending on operating conditions (payload, acceleration/deceleration, etc.). Please refer to P. 149 for more information.
- The radial cylinder is equipped with a built-in guide. Please refer to the graphs shown on P.147 and after for the allowable load mass.

## Actuator Specifications

### Lead and Payload

Model Number	Motor wattage (W)	Lead (mm)	Max. payload		Rated thrust (N)	Stroke (mm)
			Horizontal (kg)	Vertical (kg)		
RCS4-WRA14C-WA-200-24-①-T2-②-③	200	24	25	3	142	50~600 (50mm increments)
RCS4-WRA14C-WA-200-16-①-T2-②-③		16	50	8	214	
RCS4-WRA14C-WA-200-8-①-T2-②-③		8	65	20	427	
RCS4-WRA14C-WA-200-4-①-T2-②-③		4	85	30	855	

Legend: ① Stroke ② Cable Length ③ Option

### Stroke and Max Speed

(Unit: mm/s)

Lead	Stroke	50~500 (50mm increments)		
		550 (mm)	600 (mm)	600 (mm)
24		1200	1200	1200
16		800	800	800
8		480	450	390
4		240	220	190

## Cable Length

Type	Cable Code
Standard	P (1m)
	S (3m)
	M (5m)
Specified length (Standard cable)	X06 (6m) ~ X10 (10m)
	X11 (11m) ~ X15 (15m)
	X16 (16m) ~ X20 (20m)
	R01 (1m) ~ R03 (3m)
	R04 (4m) ~ R05 (5m)
Robot cable	R06 (6m) ~ R10 (10m)
	R11 (11m) ~ R15 (15m)
	R16 (16m) ~ R20 (20m)

## Actuator Specifications

Item	Description
Drive system	Ball screw ø12mm, rolled C10
Positioning repeatability	±0.01mm
Lost motion	0.1mm or less
Rod	ø40mm Stainless steel
Rod non-rotation precision (*1)	0 degrees
Allowable load and torque on rod tip	Please see P. 80
Rod tip offset/overhang distance	dx: 100mm or less / dz: 150mm or less
Ambient operating temp. & humidity	0~40°C, 85% RH or less (Non-condensing)

(\*1) Rod's angular displacement in rotational direction with no load applied to the rod.

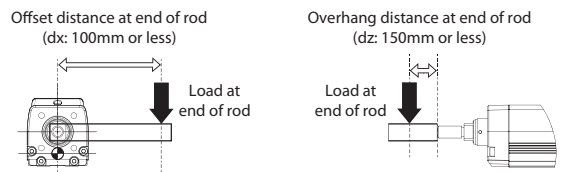

## Options

Name	Option Code	Reference Page
Brake	B	See P.131
Cable exit direction (Top)	CJT	See P.131
Cable exit direction (Right)	CJR	See P.131
Cable exit direction (Left)	CJL	See P.131
Cable exit direction (Bottom)	CJB	See P.131
Flange	FL	See P.132
Non-motor end specification	NM	See P.136
T-slot nut bar (Left)	NTBL	See P.136
T-slot nut bar (Right)	NTBR	See P.136

Round cable joint connector with screw locking (*1)	EU	See P.131
---	----	-----------

(\*1) EU option will be available soon.





# RCS4-WRA16C

Battery-less Absolute
Motor Unit Coupled
Straight Motor
Body Width 160 mm
230v AC Servo Motor

Model Specification Items	<b>RCS4</b> — <b>WRA16C</b> — <b>WA</b> — <b>400</b> — [ ] — [ ] — <b>T2</b> — [ ] — [ ]							
Series	Type	Encoder Type	Motor Type	Lead	Stroke	Applicable Controllers	Cable Length	Options
	WA: Battery-less Absolute	400: Servo motor 400W	30:30mm 20:20mm 10:10mm 5: 5mm	50:50mm 800:800mm (50mm increments)	T2:SCON SSEL XSEL-P/Q XSEL-RA/SA	N : None P : 1m S : 3m M : 5m X [ ] : Specified Length R [ ] : Robot Cable	Refer to Options table below. * Be sure to select a direction for the cable exit direction.	

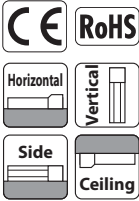

\* Depending on the model, there may be some limitations to using the vertical, side, and ceiling mount positions. Please refer to the Selection Notes on P.138 for more information.

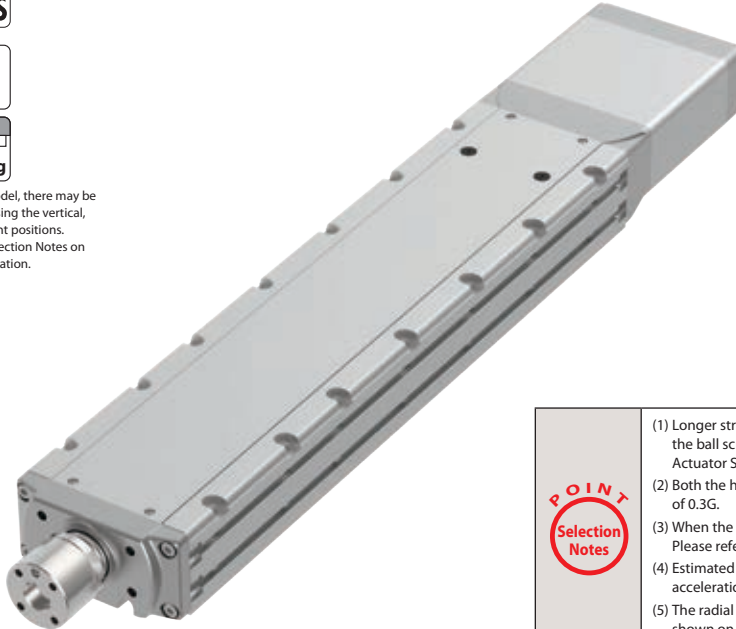

**POINT Selection Notes**

- (1) Longer strokes may cause the maximum speed to decrease due to resonance of the ball screw. Be sure to check the maximum speed of the desired stroke in the Actuator Specifications table, which can be found below.
- (2) Both the horizontal and vertical payloads assume operation at an acceleration of 0.3G.
- (3) When the acceleration is increased, the payload will be reduced. Please refer to "Table of Payload by Acceleration" on P.139 for more details.
- (4) Estimated allowable duty varies depending on operating conditions (payload, acceleration/deceleration, etc.). Please refer to P. 149 for more information.
- (5) The radial cylinder is equipped with a built-in guide. Please refer to the graphs shown on P.147 and after for the allowable load mass.

## Actuator Specifications

### Lead and Payload

Model Number	Motor wattage (W)	Lead (mm)	Max. payload		Rated thrust (N)	Stroke (mm)
			Horizontal (kg)	Vertical (kg)		
RCS4-WRA16C-WA-400-30-①-T2-②-③	400	30	30	6	226	50~800 (50mm increments)
RCS4-WRA16C-WA-400-20-①-T2-②-③		20	60	12	339	
RCS4-WRA16C-WA-400-10-①-T2-②-③		10	80	35	678	
RCS4-WRA16C-WA-400-5-①-T2-②-③		5	100	50	1357	

Legend: ① Stroke ② Cable Length ③ Option

### Stroke and Max Speed

(Unit: mm/s)

Stroke / Lead	Max Speed (mm/s)											
	50~250 (5mm increments)	300	350	400	450	500	550	600	650	700	750	800
30	1300	1050	860	710	600	510	440	390	340	300	270	
20	1000	880	700	570	470	400	340	295	260	225	200	180
10	500	430	340	280	230	195	165	145	125	110	100	90
5	250	210	170	130	115	95	80	70	60	55	50	45

## Cable Length

Type	Cable Code
Standard	P (1m)
	S (3m)
	M (5m)
Specified length (Standard cable)	X06 (6m) ~ X10 (10m)
	X11 (11m) ~ X15 (15m)
	X16 (16m) ~ X20 (20m)
	R01 (1m) ~ R03 (3m)
Robot cable	R04 (4m) ~ R05 (5m)
	R06 (6m) ~ R10 (10m)
	R11 (11m) ~ R15 (15m)
	R16 (16m) ~ R20 (20m)

## Actuator Specifications

Item	Description
Drive system	Ball screw ø16mm, rolled C10
Positioning repeatability	±0.01mm
Lost motion	0.1mm or less
Rod	ø45mm Stainless steel
Rod non-rotation precision (*1)	0 degrees
Allowable load and torque on rod tip	Please see P. 82
Rod tip offset/overhang distance	dx: 100mm or less / dz: 150mm or less
Ambient operating temp. & humidity	0~40°C, 85% RH or less (Non-condensing)

(\*1) Rod's angular displacement in rotational direction with no load applied to the rod.

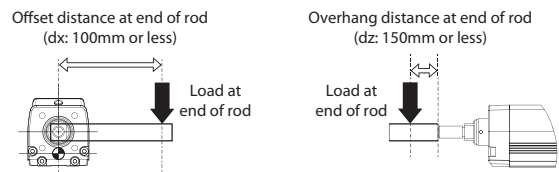

## Options

Name	Option Code	Reference Page
Brake	B	See P.131
Cable exit direction (Top)	CJT	See P.131
Cable exit direction (Right)	CJR	See P.131
Cable exit direction (Left)	CJL	See P.131
Cable exit direction (Bottom)	CJB	See P.131
Flange	FL	See P.132
Non-motor end specification	NM	See P.136
T-slot nut bar (Left)	NTBL	See P.136
T-slot nut bar (Right)	NTBR	See P.136

Round cable joint connector with screw locking (*1)	EU	See P.131
---	----	-----------

(\*1) EU option will be available soon.

## Dimensions

CAD drawings can be downloaded from our website.  
[www.robocylinder.de](http://www.robocylinder.de)



\*1 When the rod is returning to its home position, please be careful of interference from surrounding objects, as it will travel until it reaches the M.E.  
 M.E: Mechanical end S.E: Stroke end

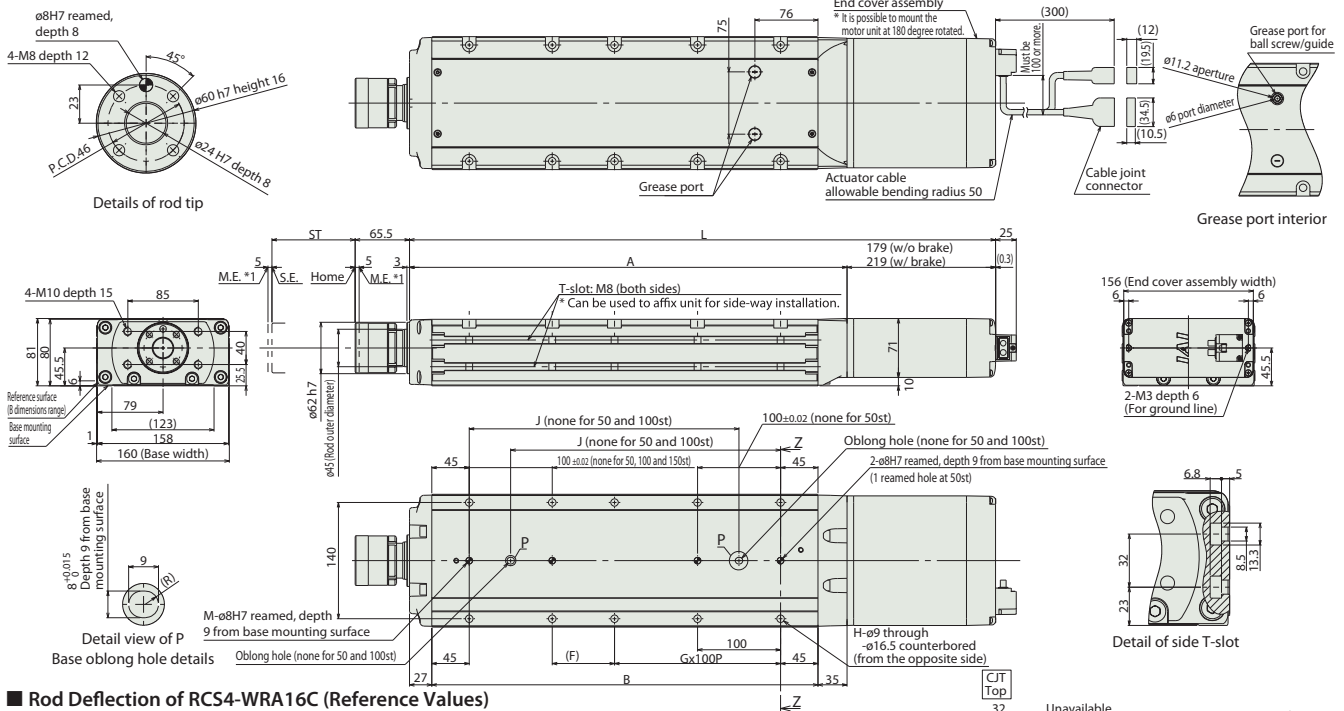

### ■ Rod Deflection of RCS4-WRA16C (Reference Values)

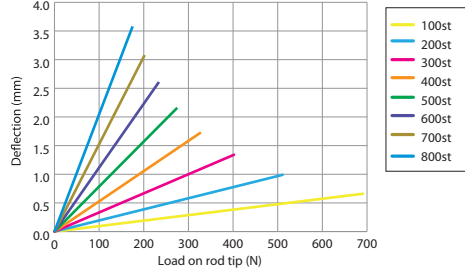

### ■ Dimensions and Mass by Stroke

L	ST	50	100	150	200	250	300	350	400	450	500	550	600	650	700	750	800
	W/o brake	456	506	556	606	656	706	756	806	856	906	956	1006	1056	1106	1156	1206
W/ brake	496	546	596	646	696	746	796	846	896	946	996	1046	1096	1146	1196	1246	
A	277	327	377	427	477	527	577	627	677	727	777	827	877	927	977	1027	
B	215	265	315	365	415	465	515	565	615	665	715	765	815	865	915	965	
F	125	75	125	75	125	75	125	75	125	75	125	75	125	75	125	75	
G	0	1	1	1	1	2	2	3	3	4	4	5	5	6	6	7	
H	4	6	6	8	8	10	10	12	12	14	14	16	16	18	18	20	
J	-	-	175	225	275	325	375	425	475	525	575	625	675	725	775	825	
M	1	1	1	2	2	2	2	2	2	2	2	2	2	2	2	2	
Allowable static load on rod tip (N)	588	588	588	511	451	402	362	329	300	275	254	235	217	202	188	176	
	40	40	40	40	40	40	40	40	40	40	40	40	40	40	40	40	
Allowable static torque on rod tip (N-m)	255	220	191	168	149	134	120	109	99	90	81	74	67	61	55	50	
	133	133	133	133	133	122	111	101	92	84	77	70	64	58	53	48	
Allowable dynamic torque on rod tip (N-m)	20.0	20.0	20.0	20.0	20.0	18.3	16.7	15.2	13.8	12.6	11.5	10.5	9.6	8.7	7.9	7.1	
	214	184	160	140	124	111	99	89	80	72	65	59	53	47	42	37	
Allowable load on rod tip (N)	133	133	133	124	112	101	91	83	75	68	62	56	50	45	40	36	
	20.0	20.0	20.0	18.6	16.8	15.2	13.7	12.4	11.3	10.2	9.2	8.4	7.5	6.8	6.0	5.3	
Mass (kg)	11.4	12.5	13.6	14.8	15.9	17.1	18.2	19.4	20.5	21.7	22.8	24.0	25.1	26.3	27.4	28.6	
	12.0	13.1	14.2	15.4	16.5	17.7	18.8	20.0	21.1	22.3	23.4	24.6	25.7	26.9	28.0	29.2	

## Applicable Controllers

The RCS4 series actuators can be operated by the controllers indicated below. Please select the type depending on your intended use.

Name	External view	Max. number of connectable axes	Input power	Control method				Maximum number of positioning points	Reference page
				Positioner	Pulse train	Program	Network * Option		
SCON-CB/CGB		1	Single phase 230VAC	●	●	-	DeviceNet CC-Link CANopen	512 (768 for network spec.)	Please see P.151
SCON-LC/LCG (*)		1	Single phase 230VAC	-	-	●	CompoNet EtherCAT	512 (768 for network spec.)	Please see the dedicated controller catalog or manual.
SSEL-CS		2	Single phase 115V/230VAC	●	-	●	EtherNet/IP	20000	
XSEL-P/Q or XSEL-RA/SA (*)		6 or 8 (Depending on the type)	Single phase 230VAC Three-phase 230VAC	-	-	●	Note: The type of compatible networks will vary depending on the controller. Please refer to the reference page for more information.	20000 or 55000 (Depending on the type)	

(\*) Coming soon

Foreword  
Slider Type  
Wide Slider Type  
Rod Type  
Radial Cylinder  
Wide Radial Cylinder  
Table Type  
Cleanroom Slider  
Cleanroom Wide Slider  
Options  
Reference Data  
Controller

# RCS4-WRA10R

Battery-less Absolute
Motor Unit Coupled
Side-mounted Motor
Body Width 100\* mm
230v AC Servo Motor

Model Specification Items	<b>RCS4</b> — <b>WRA10R</b> — <b>WA</b> — <b>60</b> — [ ] — [ ] — <b>T2</b> — [ ] — [ ]	* Body width does not include the width of the side-mounted motor.
	Series — Type — Encoder Type — Motor Type — Lead — Stroke — Applicable Controllers — Cable Length — Options WA: Battery-less Absolute    60: Servo motor 60W    16: 16mm 10: 10mm 5: 5mm 2.5: 2.5mm    50: 50mm 500: 500mm (50mm increments)    T2: SCON MSCON SSEL XSEL-P/Q XSEL-RA/SA    N: None P: 1m S: 3m M: 5m    Refer to Options table below.    X□□: Specified Length R□□: Robot Cable	

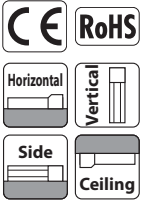

\* Depending on the model, there may be some limitations to using the vertical, side, and ceiling mount positions. Please refer to the Selection Notes on P.138 for more information.

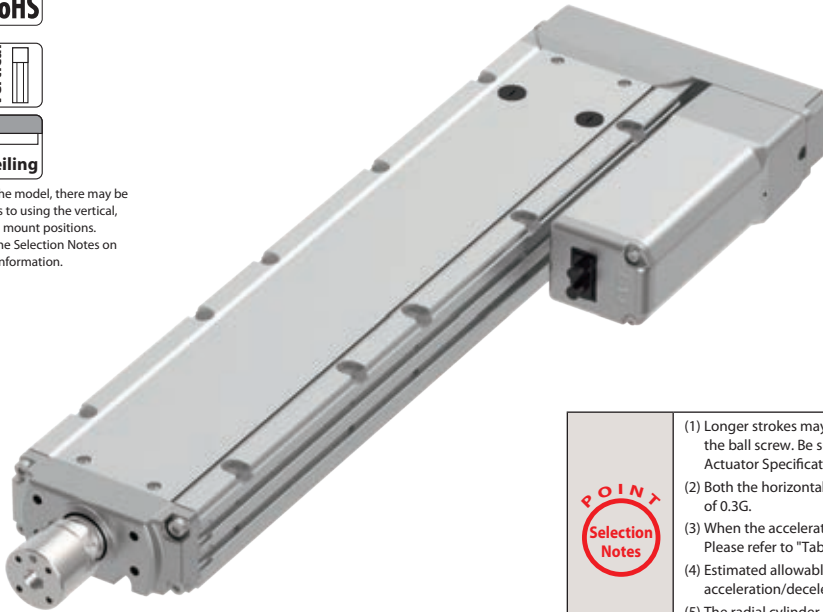

- Longer strokes may cause the maximum speed to decrease due to resonance of the ball screw. Be sure to check the maximum speed of the desired stroke in the Actuator Specifications table, which can be found below.
- Both the horizontal and vertical payloads assume operation at an acceleration of 0.3G.
- When the acceleration is increased, the payload will be reduced. Please refer to "Table of Payload by Acceleration" on P.139 for more details.
- Estimated allowable duty varies depending on operating conditions (payload, acceleration/deceleration, etc.). Please refer to P. 149 for more information.
- The radial cylinder is equipped with a built-in guide. Please refer to the graphs shown on P.147 and after for the allowable load mass.

## Actuator Specifications

### Lead and Payload

Model Number	Motor wattage (W)	Lead (mm)	Max. payload		Rated thrust (N)	Stroke (mm)
			Horizontal (kg)	Vertical (kg)		
RCS4-WRA10R-WA-60-16-①-T2-②-③	60	16	5	—	53	50~500 (50mm increments)
RCS4-WRA10R-WA-60-10-①-T2-②-③		10	13	2.5	85	
RCS4-WRA10R-WA-60-5-①-T2-②-③		5	25	5	170	
RCS4-WRA10R-WA-60-2.5-①-T2-②-③		2.5	40	10	340	

Legend: ① Stroke ② Cable Length ③ Option

### Stroke and Max Speed

Lead	Stroke	(Unit: mm/s)		
		50~400 (50mm increments)	450 (mm)	500 (mm)
16		800		770
10		600	580	490
5		300	290	240
2.5		150	145	120

## Cable Length

Type	Cable Code
Standard	P (1m)
	S (3m)
	M (5m)
Specified length (Standard cable)	X06 (6m) ~ X10 (10m)
	X11 (11m) ~ X15 (15m)
	X16 (16m) ~ X20 (20m)
	R01 (1m) ~ R03 (3m)
Robot cable	R04 (4m) ~ R05 (5m)
	R06 (6m) ~ R10 (10m)
	R11 (11m) ~ R15 (15m)
	R16 (16m) ~ R20 (20m)
	R16 (16m) ~ R20 (20m)

## Actuator Specifications

Item	Description
Drive system	Ball screw ø8mm, rolled C10
Positioning repeatability	±0.01mm
Lost motion	0.1mm or less
Rod	ø25mm Stainless steel
Rod non-rotation precision (*1)	0 degrees
Allowable load and torque on rod tip	Please see P. 84
Rod tip offset/overhang distance	dx/dz: 100mm or less
Ambient operating temp. & humidity	0~40°C, 85% RH or less (Non-condensing)

(\*1) Rod's angular displacement in rotational direction with no load applied to the rod.

Offset distance at end of rod (dx: 100mm or less)

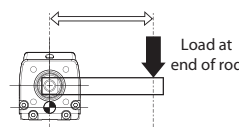

Overhang distance at end of rod (dz: 100mm or less)

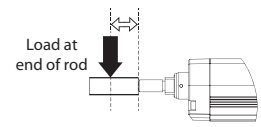

## Options

Name	Option Code	Reference Page
Brake	B	See P.131
Cable exit direction (Top)	CJT	See P.131
Cable exit direction (Bottom)	CJB	See P.131
Cable exit direction (Outside)	CJO	See P.131
Flange (*1)	FL	See P.132
Motor side-mounted to left (standard)	ML	See P.135
Motor side-mounted to right	MR	See P.135
Non-motor end specification	NM	See P.136
T-slot nut bar (Left) (*1)	NTBL	See P.136
T-slot nut bar (Right) (*1)	NTBR	See P.136

Round cable joint connector with screw locking (*2)	EU	See P.131
---	----	-----------

(\*1) Be sure to confirm with the "Selection Notes (P.138)" when selecting options. (\*2) EU option will be available soon.

## Dimensions

CAD drawings can be downloaded from our website.

www.robocylinder.de



\*1 When the rod is returning to its home position, please be careful of interference from surrounding objects, as it will travel until it reaches the M.E.  
M.E: Mechanical end S.E: Stroke end

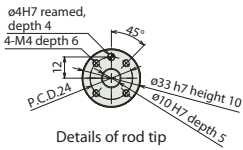

Details of rod tip

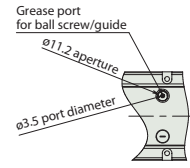
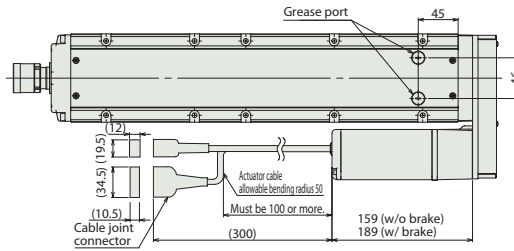

Grease port interior

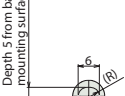
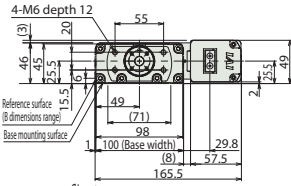

Detail view of P Base oblong hole details

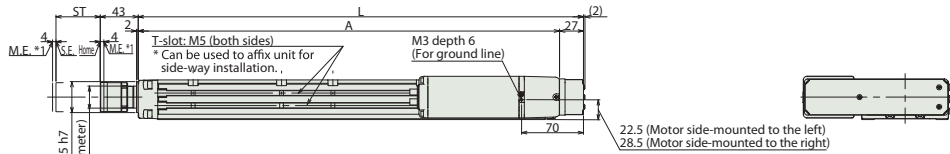

M-ø5H7 reamed, depth 5 from base mounting surface  
Oblong hole (none for 50 and 100st)

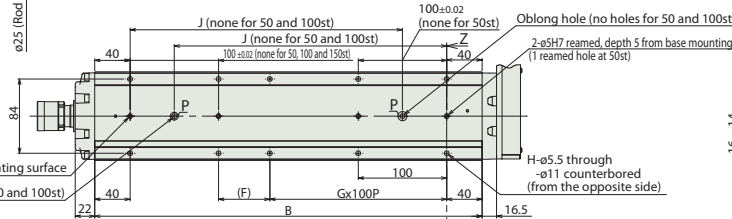

Detail of side T-slot

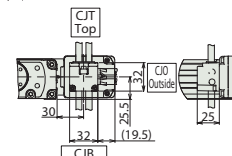

Cable exit direction (Option)

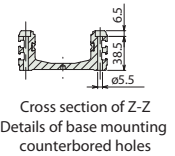

Cross section of Z-Z Details of base mounting counterbored holes

## Dimensions and Mass by Stroke

	ST	50	100	150	200	250	300	350	400	450	500
L		253.5	303.5	353.5	403.5	453.5	503.5	553.5	603.5	653.5	703.5
A		226.5	276.5	326.5	376.5	426.5	476.5	526.5	576.5	626.5	676.5
B		188	238	288	338	388	438	488	538	588	638
F		108	58	108	58	108	58	108	58	108	58
G		0	1	1	1	1	2	2	3	3	4
H		4	6	6	8	8	10	10	12	12	14
J		-	-	158	208	258	308	358	408	458	508
M		1	1	1	2	2	2	2	2	2	2
Allowable static load on rod tip (N)		196	196	196	196	196	196	196	196	184	169
Allowable static torque on rod tip (N-m)		10	10	10	10	10	10	10	10	10	10
3000km	Allowable load on rod tip (N)	98	98	98	95	85	76	68	62	57	52
	Load offset 0mm	50	50	50	50	50	50	50	50	50	49
5000km	Allowable dynamic torque on rod tip (N-m)	5.0	5.0	5.0	5.0	5.0	5.0	5.0	5.0	5.0	4.9
	Load offset 100mm	98	98	91	80	71	63	57	52	47	43
Mass (kg)	W/o brake	3.7	4.2	4.6	5.1	5.6	6.0	6.5	6.9	7.4	7.8
	W/ brake	4	4.5	4.9	5.4	5.9	6.3	6.8	7.2	7.7	8.1

## Rod Deflection of RCS4-WRA10R (Reference Values)

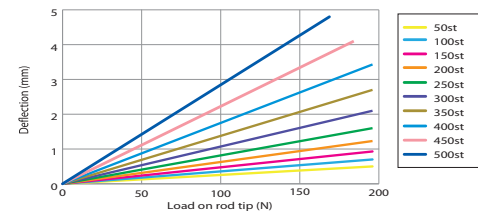

## Applicable Controllers

The RCS4 series actuators can be operated by the controllers indicated below. Please select the type depending on your intended use.

Name	External view	Max. number of connectable axes	Input power	Control method				Maximum number of positioning points	Reference page	
				Positioner	Pulse train	Program	Network * Option			
SCON-CB/CGB		1	Single phase 115V/230VAC	●	●	-	DeviceNet CC-Link CompoNet	512 (768 for network spec.)	Please see P.151	
SCON-LC/LCG (*)		1		-	-	●		EtherCAT EtherNet/IP		512 (768 for network spec.)
SCON-CAL/CGAL		1		●	-	-				512 (768 for network spec.)
MSCON-C		6		This model is network-compatible only.				256		Please see the dedicated controller catalog or manual.
SSEL-CS		2		●	-	●	20000			
XSEL-P/Q or XSEL-RA/SA (*)		6 or 8 (Depending on the type)		Single phase 230VAC Three-phase 230VAC	-	-	●	20000 or 55000 (Depending on the type)		

(\*) Coming soon



## Dimensions

CAD drawings can be downloaded from our website.  
www.robocylinder.de



\*1 When the rod is returning to its home position, please be careful of interference from surrounding objects, as it will travel until it reaches the M.E.  
M.E: Mechanical end S.E: Stroke end

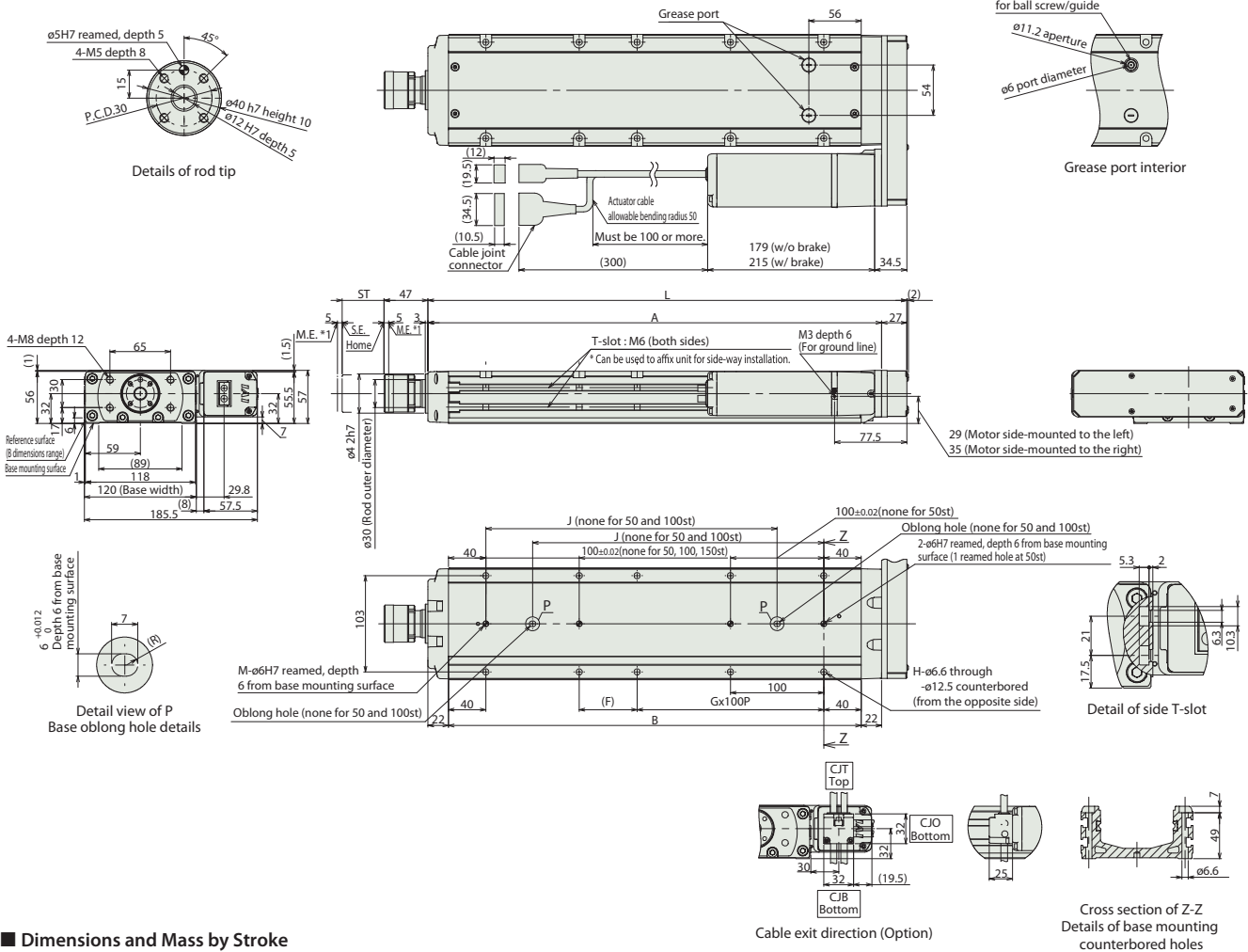

### ■ Dimensions and Mass by Stroke

	ST	50	100	150	200	250	300	350	400	450	500
ST		50	100	150	200	250	300	350	400	450	500
L		263	313	363	413	463	513	563	613	663	713
A		236	286	336	386	436	486	536	586	636	686
B		192	242	292	342	392	442	492	542	592	642
F		112	62	112	62	112	62	112	62	112	62
G		0	1	1	1	1	2	2	3	3	4
H		4	6	6	8	8	10	10	12	12	14
J		-	-	162	212	262	312	362	412	462	512
M		1	1	1	2	2	2	2	2	2	2
Allowable static load on rod tip (N)		294	294	294	294	294	269	241	218	198	181
Allowable static torque on rod tip (N·m)		20	20	20	20	20	20	20	20	20	20
3000km	Allowable load on rod tip (N)	147	147	137	121	107	96	87	79	72	65
	Load offset 0mm	100	100	100	100	99	90	82	75	68	63
	Load offset 100mm	10.0	10.0	10.0	10.0	9.9	9.0	8.2	7.5	6.8	6.3
5000km	Allowable load on rod tip (N)	147	133	115	101	90	80	72	65	59	54
	Load offset 0mm	100	100	100	92	83	75	68	62	56	51
	Load offset 100mm	10.0	10.0	10.0	9.2	8.3	7.5	6.8	6.2	5.6	5.1
Mass (kg)	W/o brake	5.2	5.9	6.5	7.2	7.8	8.5	9.1	9.8	10.4	11.1
	W/brake	5.5	6.2	6.8	7.5	8.1	8.8	9.4	10.1	10.7	11.4

### ■ Rod Deflection of RCS4-WRA12R (Reference Values)

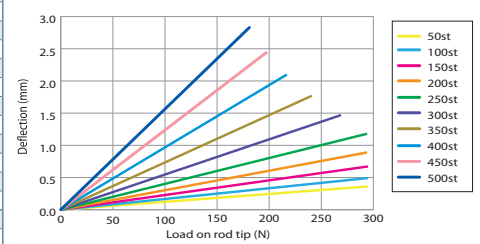

## Applicable Controllers

The RCS4 series actuators can be operated by the controllers indicated below. Please select the type depending on your intended use.

Name	External view	Max. number of connectable axes	Input power	Control method				Maximum number of positioning points	Reference page	
				Positioner	Pulse train	Program	Network * Option			
SCON-CB/CGB		1	Single phase 115V/230VAC	●	●	-	<b>DeviceNet</b> <b>CC-Link</b> <b>PROFINET</b> <b>CompoNet</b> <b>EtherCAT</b> <b>EtherNet/IP</b>	512 (768 for network spec.)	Please see the dedicated controller catalog or manual.	
SCON-LC/LCG (*)		1		-	-	●		512 (768 for network spec.)		
SCON-CAL/CGAL		1		●	-	-		512 (768 for network spec.)		
MSCON-C		6		This model is network-compatible only.				256		
SSEL-CS		2		●	-	●		20000		
XSEL-P/Q or XSEL-RA/SA (*)		6 or 8 (Depending on the type)	Single phase 230VAC Three-phase 230VAC	-	-	●	20000 or 55000 (Depending on the type)			

(\*) Coming soon

# RCS4-WRA14R

Battery-less Absolute

Motor Unit Coupled

Side-mounted Motor

Body Width 140\* mm

230v AC Servo Motor

<b>Model Specification Items</b>	<b>RCS4</b>	<b>WRA14R</b>	<b>WA</b>	<b>200</b>								* Body width does not include the width of the side-mounted motor.
	Series	Type	Encoder Type	Motor Type	Lead	Stroke	Applicable Controllers	Cable Length	Options			
			WA: Battery-less Absolute	200: Servo motor 200W	24:24mm 16:16mm 8: 8mm 4: 4mm	50:50mm + 600:600mm (50mm increments)	T2:SCON MSCON SSEL XSEL-P/Q XSEL-RA/SA	N : None P : 1m S : 3m M : 5m X□□ : Specified Length R□□ : Robot Cable	Refer to Options table below.			

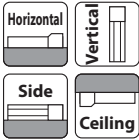

\* Depending on the model, there may be some limitations to using the vertical, side, and ceiling mount positions. Please refer to the Selection Notes on P.138 for more information.

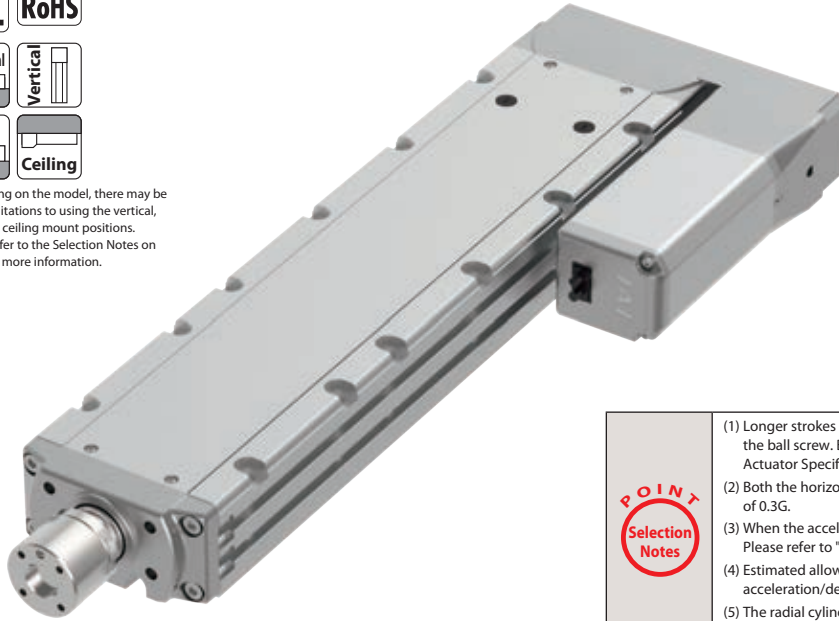

POINT  
Selection Notes

(1) Longer strokes may cause the maximum speed to decrease due to resonance of the ball screw. Be sure to check the maximum speed of the desired stroke in the Actuator Specifications table, which can be found below.

(2) Both the horizontal and vertical payloads assume operation at an acceleration of 0.3G.

(3) When the acceleration is increased, the payload will be reduced. Please refer to "Table of Payload by Acceleration" on P.139 for more details.

(4) Estimated allowable duty varies depending on operating conditions (payload, acceleration/deceleration, etc.). Please refer to P. 149 for more information.

(5) The radial cylinder is equipped with a built-in guide. Please refer to the graphs shown on P.147 and after for the allowable load mass.

### Actuator Specifications

#### Lead and Payload

Model Number	Motor wattage (W)	Lead (mm)	Max. payload		Rated thrust (N)	Stroke (mm)
			Horizontal (kg)	Vertical (kg)		
RCS4-WRA14R-WA-200-24-①-T2-②-③	200	24	25	3	142	50~600 (50mm increments)
RCS4-WRA14R-WA-200-16-①-T2-②-③		16	50	8	214	
RCS4-WRA14R-WA-200-8-①-T2-②-③		8	65	20	427	
RCS4-WRA14R-WA-200-4-①-T2-②-③		4	85	30	855	

Legend: ① Stroke ② Cable Length ③ Option

#### Stroke and Max Speed

Lead	Stroke	Max Speed (Unit: mm/s)		
		50~500 (50mm increments)	550 (mm)	600 (mm)
24		1200		
16		800		
8		480	450	390
4		240	220	190

### Cable Length

Type	Cable Code
Standard	P (1m)
	S (3m)
	M (5m)
Specified length (Standard cable)	X06 (6m) ~ X10 (10m)
	X11 (11m) ~ X15 (15m)
	X16 (16m) ~ X20 (20m)
Robot cable	R01 (1m) ~ R03 (3m)
	R04 (4m) ~ R05 (5m)
	R06 (6m) ~ R10 (10m)
	R11 (11m) ~ R15 (15m)
	R16 (16m) ~ R20 (20m)

### Options

Name	Option Code	Reference Page
Brake	B	See P.131
Cable exit direction (Top)	CJT	See P.131
Cable exit direction (Bottom)	CJB	See P.131
Cable exit direction (Outside)	CJO	See P.131
Flange (*1)	FL	See P.132
Motor side-mounted to left (standard)	ML	See P.135
Motor side-mounted to right	MR	See P.135
Non-motor end specification	NM	See P.136
T-slot nut bar (Left) (*1)	NTBL	See P.136
T-slot nut bar (Right) (*1)	NTBR	See P.136

### Actuator Specifications

Item	Description
Drive system	Ball screw ø12mm, rolled C10
Positioning repeatability	±0.01mm
Lost motion	0.1mm or less
Rod	ø40mm Stainless steel
Rod non-rotation precision (*1)	0 degrees
Allowable load and torque on rod tip	Please see P. 88
Rod tip offset/overhang distance	dx: 100mm or less / dz: 150mm or less
Ambient operating temp. & humidity	0~40°C, 85% RH or less (Non-condensing)

(\*1) Rod's angular displacement in rotational direction with no load applied to the rod.

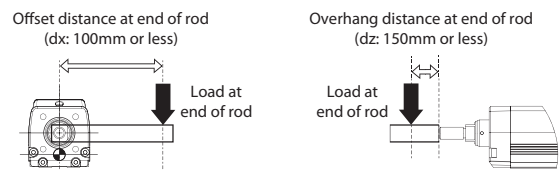

Round cable joint connector with screw locking (*2)	EU	See P.131
---	----	-----------

(\*1) Be sure to confirm with the "Selection Notes (P.138)" when selecting options. (\*2) EU option will be available soon.









# RCS4-TA4C <with Single-block Guide>

Battery-less Absolute
Motor Unit Coupled
Straight Motor
Body Width 40 mm
230v AC Servo Motor

Model Specification Items	<b>RCS4</b> — <b>TA4C</b> — <b>WA</b> — <b>60</b> — [ ] — [ ] — [ ] — <b>T2</b> — [ ] — [ ]
	Series — Type — Encoder Type — Motor Type — Lead — Stroke — Applicable Controllers — Cable Length — Options
	WA: Battery-less Absolute 60: Servo motor 60W 16: 16mm 10: 10mm 5: 5mm 2.5: 2.5mm 25: 25mm 150: 150mm (25mm increments) T2: SCON, MSCON, SSEL, XSEL-P/Q, XSEL-RA/SA N: None, P: 1m, S: 3m, M: 5m X□□: Specified Length, R□□: Robot Cable Refer to Options table below.



\* Depending on the model, there may be some limitations to using the vertical, side, and ceiling mount positions. Please refer to the Selection Notes on P.138 for more information.



**POINT Selection Notes**

- Both the horizontal and vertical payloads assume operation at an acceleration of 0.3G.
- When the acceleration is increased, the payload will be reduced. Please refer to "Table of Payload by Acceleration" on P.139 for more details.
- Estimated allowable duty varies depending on operating conditions (payload, acceleration/deceleration, etc.). Please refer to P. 149 for more information.
- Please refer to the graphs shown on P.148 for the allowable load mass.

### Actuator Specifications

#### Lead and Payload

Model Number	Motor wattage (W)	Lead (mm)	Max. payload		Rated thrust (N)	Stroke (mm)
			Horizontal (kg)	Vertical (kg)		
RCS4-TA4C-WA-60-16-①-T2-②-③	60	16	4	1.5	53	25~150 (25mm increments)
RCS4-TA4C-WA-60-10-①-T2-②-③		10	5	3	85	
RCS4-TA4C-WA-60-5-①-T2-②-③		5	5	6	170	
RCS4-TA4C-WA-60-2.5-①-T2-②-③		2.5	5	9	340	

Legend: ① Stroke ② Cable Length ③ Option

#### Stroke and Max Speed (Unit: mm/s)

Lead	Stroke	
	Stroke	25~150 (mm)
16	900	
10	600	
5	300	
2.5	150	

### Cable Length

Type	Cable Code
Standard	P (1m)
	S (3m)
	M (5m)
Specified length (Standard cable)	X06 (6m) ~ X10 (10m)
	X11 (11m) ~ X15 (15m)
	X16 (16m) ~ X20 (20m)
	R01 (1m) ~ R03 (3m)
Robot cable	R04 (4m) ~ R05 (5m)
	R06 (6m) ~ R10 (10m)
	R11 (11m) ~ R15 (15m)
	R16 (16m) ~ R20 (20m)

### Actuator Specifications

Item	Description
Drive system	Ball screw ø8mm, rolled C10
Positioning repeatability	±0.01mm
Lost motion	0.1mm or less
Base	Material: Aluminum with white alumite treatment
Allowable static moment	Ma direction 13N·m, Mb direction 18.6N·m, Mc direction 25.3N·m
Allowable dynamic moment (*1)	Ma direction 4.98N·m, Mb direction 7.11N·m, Mc direction 9.68N·m
Ambient operating temp. & humidity	0~40°C, 85% RH or less (Non-condensing)

(\*1) Assumes a standard rated life of 5000km. The service life will vary depending on operation and installation conditions. Please contact IAI for details of the running life.

Allowable load moment directions

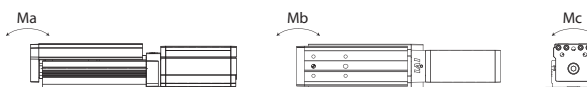

If the load moments in Ma/Mb/Mc direction are within the allowable ranges, there is no overhanging load length limit. Please refer to the RCS4 manual regarding the displacement of the table.

### Options

Name	Option Code	Reference Page
Brake	B	See P.131
Cable exit direction (Top)	CJT	See P.131
Cable exit direction (Right)	CJR	See P.131
Cable exit direction (Left)	CJL	See P.131
Cable exit direction (Bottom)	CJB	See P.131
Non-motor end specification	NM	See P.136

(\*1) EU option will be available soon.

Round cable joint connector with screw locking (*1)	EU	See P.131
---	----	-----------

## Dimensions

CAD drawings can be downloaded from our website.

www.robocylinder.de



\*1 When the table is returning to its home position, please be mindful of possible interference from surrounding objects, as it will travel until it reaches the M.E.  
M.E: Mechanical end S.E: Stroke end

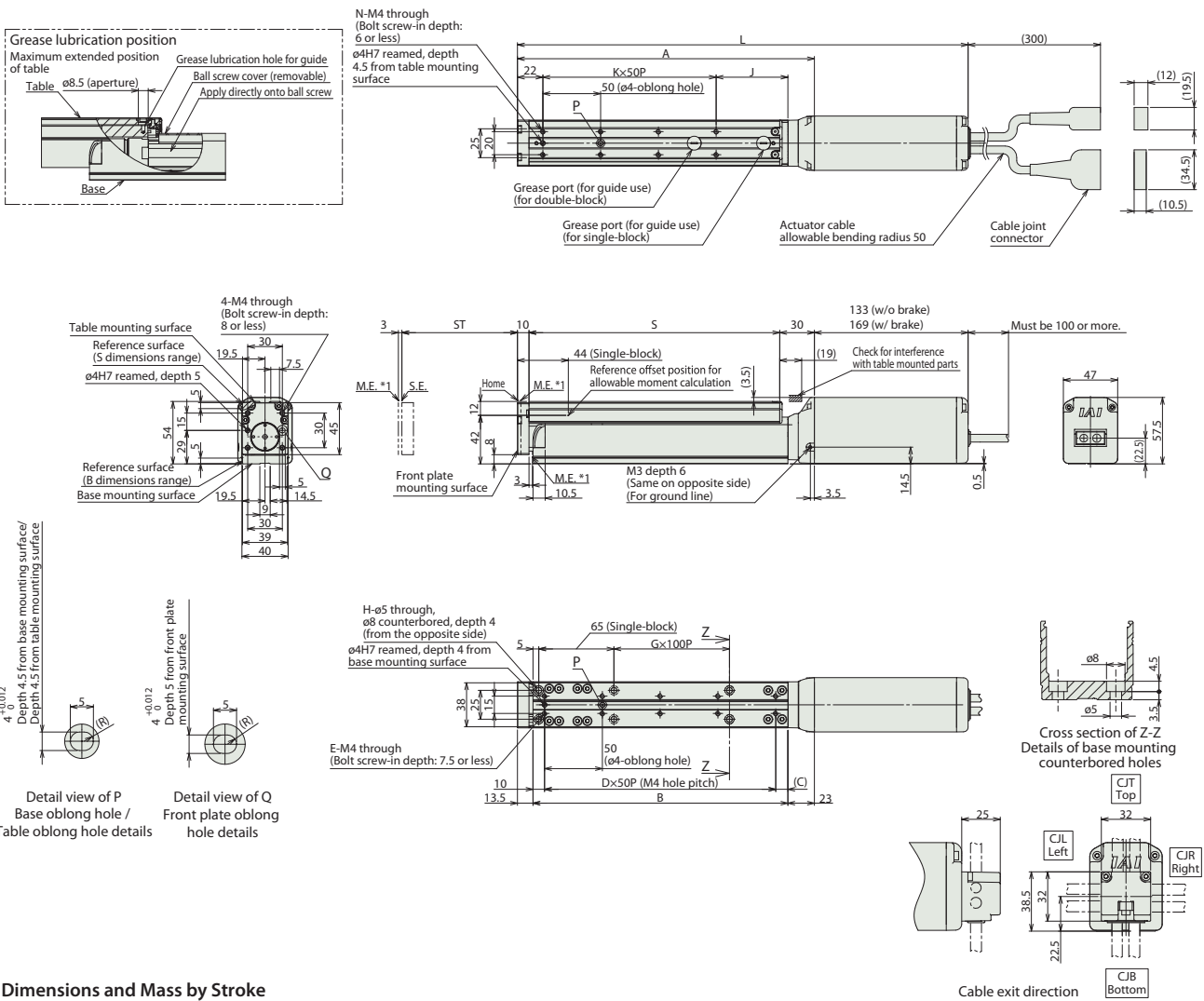

### ■ Dimensions and Mass by Stroke

		ST	25	50	75	100	125	150
L	W/o brake	265	290	315	340	365	390	
	W/ brake	301	326	351	376	401	426	
	A	132	157	182	207	232	257	
	B	95.5	120.5	145.5	170.5	195.5	220.5	
	C	35.5	10.5	35.5	10.5	35.5	10.5	
	D	1	2	2	3	3	4	
	E	4	6	6	8	8	10	
	G	0	0	0	0	1	1	
	H	4	4	4	4	6	6	
	J	37	62	37	62	37	62	
	K	1	1	2	2	3	3	
	N	4	4	6	6	8	8	
	S	92	117	142	167	192	217	
Mass (kg)	W/o brake	1.3	1.3	1.4	1.5	1.6	1.7	
	W/ brake	1.6	1.6	1.7	1.8	1.9	2.0	

### ■ Applicable Controllers

The RCS4 series actuators can be operated by the controllers indicated below. Please select the type depending on your intended use.

Name	External view	Max. number of connectable axes	Input power	Control method				Maximum number of positioning points	Reference page	
				Positioner	Pulse train	Program	Network * Option			
SCON-CB/CGB		1	Single phase 115V/230VAC	●	●	-	DeviceNet CCLink CompoNet EtherCAT EtherNet/IP Note: The type of compatible networks will vary depending on the controller. Please refer to the reference page for more information.	512 (768 for network spec.)	Please see the dedicated controller catalog or manual.	
SCON-LC/LCG (*)		1		-	-	●		512 (768 for network spec.)		
SCON-CAL/CGAL		1		●	-	-		512 (768 for network spec.)		
MSCON-C		6		This model is network-compatible only.				256		
SSEL-CS		2		●	-	●		20000		
XSEL-P/Q or XSEL-RA/SA (*)		6 or 8 (Depending on the type)	Single phase 230VAC Three-phase 230VAC	-	-	●	20000 or 55000 (Depending on the type)			

(\*) Coming soon

Foreword  
Slider Type  
Wide Slider Type  
Rod Type  
Radial Cylinder  
Wide Radial Cylinder  
Table Type  
Cleanroom Slider  
Cleanroom Wide Slider  
Options  
Reference Data  
Controller

# RCS4-TA4C□-DB <with Double-block Guide>

Battery-less Absolute
Motor Unit Coupled
Straight Motor
Body Width 40mm
230v AC Servo Motor

Model Specification Items	<b>RCS4</b>	<b>TA4C</b>	<b>WA</b>	<b>60</b>	□	□	<b>T2</b>	□	<b>DB</b>	□
	Series	Type	Encoder Type	Motor Type	Lead	Stroke	Applicable Controllers	Cable Length	Options	
			WA: Battery-less Absolute	60: Servo motor 60W	10: 10mm 5: 5mm 2.5: 2.5mm	40:40mm 240:240mm	T2:SCON MSCON SSEL XSEL-P/Q XSEL-RA/SA	N : None P : 1m S : 3m M : 5m X□□ : Specified Length R□□ : Robot Cable	Refer to Options table below.	

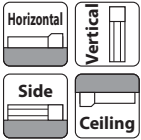

\* Depending on the model, there may be some limitations to using the vertical, side, and ceiling mount positions. Please refer to the Selection Notes on P.138 for more information.



**POINT Selection Notes**

- Both the horizontal and vertical payloads assume operation at an acceleration of 0.3G.
- When the acceleration is increased, the payload will be reduced. Please refer to "Table of Payload by Acceleration" on P.139 for more details.
- Estimated allowable duty varies depending on operating conditions (payload, acceleration/deceleration, etc.). Please refer to P. 149 for more information.
- Please refer to the graphs shown on P.148 for the allowable load mass.

## Actuator Specifications

### Lead and Payload

Model Number	Motor wattage (W)	Lead (mm)	Max. payload		Rated thrust (N)	Stroke (mm)
			Horizontal (kg)	Vertical (kg)		
RCS4-TA4C-WA-60-10-①-T2-②-DB-③	60	10	8	3	85	40~90 (25mm increments)
RCS4-TA4C-WA-60-5-①-T2-②-DB-③		5	10	6	170	140~240 (50mm increments)
RCS4-TA4C-WA-60-2.5-①-T2-②-DB-③		2.5	10	9	340	

Legend: ① Stroke ② Cable Length ③ Option

### Stroke and Max Speed (Unit: mm/s)

Lead	Stroke	
	40~240 (mm)	
10	600	
5	300	
2.5	150	

## Cable Length

Type	Cable Code
Standard	P (1m)
	S (3m)
	M (5m)
Specified length (Standard cable)	X06 (6m) ~ X10 (10m)
	X11 (11m) ~ X15 (15m)
	X16 (16m) ~ X20 (20m)
	R01 (1m) ~ R03 (3m)
Robot cable	R04 (4m) ~ R05 (5m)
	R06 (6m) ~ R10 (10m)
	R11 (11m) ~ R15 (15m)
	R16 (16m) ~ R20 (20m)

## Actuator Specifications

Item	Description
Drive system	Ball screw ø8mm, rolled C10
Positioning repeatability	±0.01mm
Lost motion	0.1mm or less
Base	Material: Aluminum with white alumite treatment
Allowable static moment	Ma direction 76.8N·m, Mb direction 110N·m, Mc direction 50.5N·m
Allowable dynamic moment (*1)	Ma direction 23.9N·m, Mb direction 34.1N·m, Mc direction 15.7N·m
Ambient operating temp. & humidity	0~40°C, 85% RH or less (Non-condensing)

(\*1) Assumes a standard rated life of 5000km. The service life will vary depending on operation and installation conditions. Please contact IAI for details of the running life.

### Allowable load moment directions

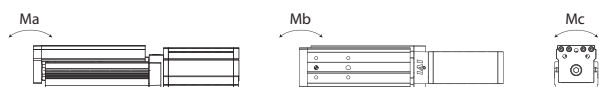

If the load moments in Ma/Mb/Mc direction are within the allowable ranges, there is no overhang load length limit. Please refer to the RCS4 manual regarding the displacement of the table.

## Options

Name	Option Code	Reference Page
Brake	B	See P.131
Cable exit direction (Top)	CJT	See P.131
Cable exit direction (Right)	CJR	See P.131
Cable exit direction (Left)	CJL	See P.131
Cable exit direction (Bottom)	CJB	See P.131
Non-motor end specification	NM	See P.136

(\*1) EU option will be available soon.

Round cable joint connector with screw locking (*1)	EU	See P.131
---	----	-----------

## Dimensions

CAD drawings can be downloaded from our website.

www.robocylinder.de



\*1 When the table is returning to its home position, please be mindful of possible interference from surrounding objects, as it will travel until it reaches the M.E.  
M.E: Mechanical end S.E: Stroke end

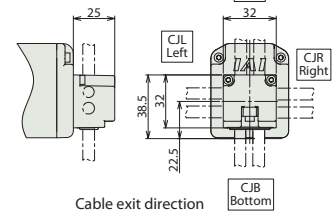
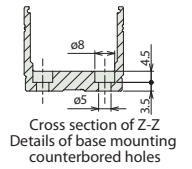
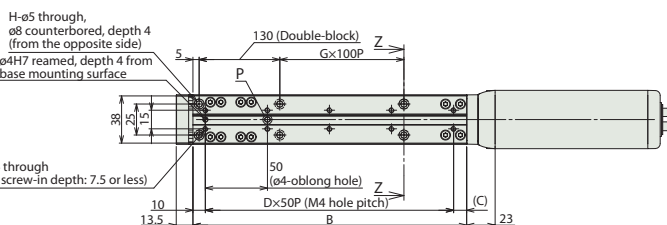
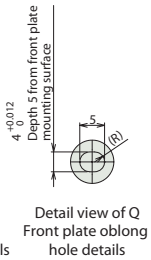
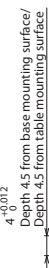
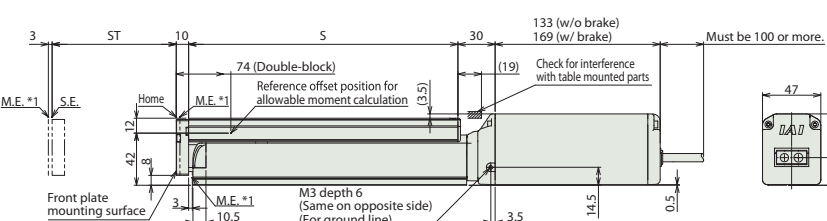
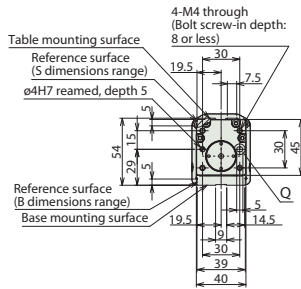
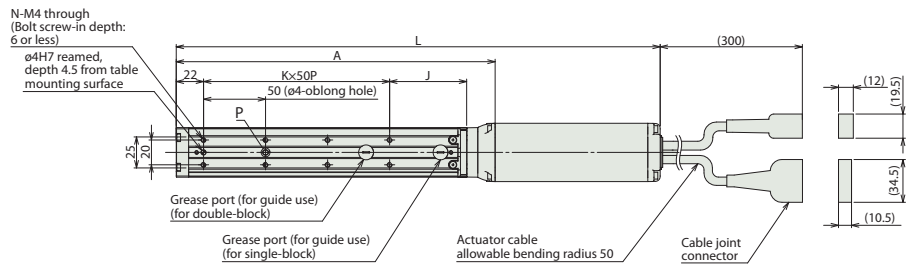
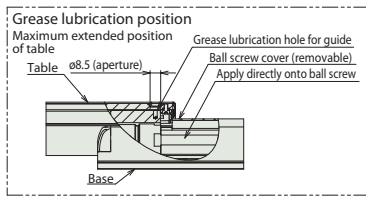

### Dimensions and Mass by Stroke

		40	65	90	140	190	240
L	W/o brake	340	365	390	440	490	540
	W/ brake	376	401	426	476	526	576
A		207	232	257	307	357	407
B		170.5	195.5	220.5	270.5	320.5	370.5
C		10.5	35.5	10.5	10.5	10.5	10.5
D		3	3	4	5	6	7
E		8	8	10	12	14	16
G		0	0	0	1	1	2
H		4	4	4	6	6	8
J		62	37	62	62	62	62
K		2	3	3	4	5	6
N		6	8	8	10	12	14
S		167	192	217	267	317	367
Mass (kg)	W/o brake	1.6	1.7	1.8	2.0	2.1	2.3
	W/ brake	1.9	2.0	2.1	2.3	2.4	2.6

### Applicable Controllers

The RCS4 series actuators can be operated by the controllers indicated below. Please select the type depending on your intended use.

Name	External view	Max. number of connectable axes	Input power	Control method				Maximum number of positioning points	Reference page	
				Positioner	Pulse train	Program	Network * Option			
SCON-CB/CGB		1	Single phase 115V/230VAC	●	●	—	DeviceNet CC-Link PROFINET CompoNet	512 (768 for network spec.)	Please see P.151	
SCON-LC/LCG (*)		1		—	—	●		EtherCAT EtherNet/IP		512 (768 for network spec.)
SCON-CAL/CGAL		1		●	—	—				512 (768 for network spec.)
MSCON-C		6		This model is network-compatible only.				256		
SSEL-CS		2		●	—	●	Note: The type of compatible networks will vary depending on the controller. Please refer to the reference page for more information.	20000		
XSEL-P/Q or XSEL-RA/SA (*)		6 or 8 (Depending on the type)		Single phase 230VAC Three-phase 230VAC	—	—	●	20000 or 55000 (Depending on the type)		

(\*) Coming soon

Foreword  
 Slider Type  
 Wide Slider Type  
 Rod Type  
 Radial Cylinder  
 Wide Radial Cylinder  
 Table Type  
 Cleanroom Slider  
 Cleanroom Wide Slider  
 Options  
 Reference Data  
 Controller

# RCS4-TA6C <with Single-block Guide>

Battery-less Absolute
Motor Unit Coupled
Straight Motor
Body Width 60 mm
230v AC Servo Motor

Model Specification Items	<b>RCS4</b> — <b>TA6C</b> — <b>WA</b> — <b>100</b> — <span style="border: 1px solid black; display: inline-block; width: 15px; height: 15px;"></span> — <span style="border: 1px solid black; display: inline-block; width: 15px; height: 15px;"></span> — <b>T2</b> — <span style="border: 1px solid black; display: inline-block; width: 15px; height: 15px;"></span> — <span style="border: 1px solid black; display: inline-block; width: 15px; height: 15px;"></span>
	Series — Type — Encoder Type — Motor Type — Lead — Stroke — Applicable Controllers — Cable Length — Options
	WA: Battery-less Absolute      100: Servo motor 100W      20:20mm 12:12mm 6: 6mm 3: 3mm      25:25mm 200:200mm (25mm increments)      T2:SCON MSCON SSEL XSEL-P/Q XSEL-RA/SA      N : None P : 1m S : 3m M : 5m X□□ : Specified Length R□□ : Robot Cable      Refer to Options table below.

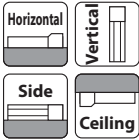

\* Depending on the model, there may be some limitations to using the vertical, side, and ceiling mount positions. Please refer to the Selection Notes on P.138 for more information.



**POINT Selection Notes**

- Both the horizontal and vertical payloads assume operation at an acceleration of 0.3G.
- When the acceleration is increased, the payload will be reduced. Please refer to "Table of Payload by Acceleration" on P.139 for more details.
- Estimated allowable duty varies depending on operating conditions (payload, acceleration/deceleration, etc.). Please refer to P. 149 for more information.
- Please refer to the graphs shown on P.148 for the allowable load mass.

## Actuator Specifications

### Lead and Payload

Model Number	Motor wattage (W)	Lead (mm)	Max. payload		Rated thrust (N)	Stroke (mm)
			Horizontal (kg)	Vertical (kg)		
RCS4-TA6C-WA-100-20-①-T2-②-③	100	20	8	4	85	25~200 (25mm increments)
RCS4-TA6C-WA-100-12-①-T2-②-③		12	8	6	142	
RCS4-TA6C-WA-100-6-①-T2-②-③		6	8	10	283	
RCS4-TA6C-WA-100-3-①-T2-②-③		3	10	12	566	

Legend: ① Stroke ② Cable Length ③ Option

### Stroke and Max Speed (Unit: mm/s)

Lead	Stroke	
	Stroke	25~200 (mm)
20		1100
12		720
6		360
3		180

## Cable Length

Type	Cable Code
Standard	P (1m)
	S (3m)
	M (5m)
Specified length (Standard cable)	X06 (6m) ~ X10 (10m)
	X11 (11m) ~ X15 (15m)
	X16 (16m) ~ X20 (20m)
	R01 (1m) ~ R03 (3m)
Robot cable	R04 (4m) ~ R05 (5m)
	R06 (6m) ~ R10 (10m)
	R11 (11m) ~ R15 (15m)
	R16 (16m) ~ R20 (20m)

## Options

Name	Option Code	Reference Page
Brake	<b>B</b>	See P.131
Cable exit direction (Top)	<b>CJT</b>	See P.131
Cable exit direction (Right)	<b>CJR</b>	See P.131
Cable exit direction (Left)	<b>CJL</b>	See P.131
Cable exit direction (Bottom)	<b>CJB</b>	See P.131
Non-motor end specification	<b>NM</b>	See P.136

(\*1) EU option will be available soon.

## Actuator Specifications

Item	Description
Drive system	Ball screw ø10mm, rolled C10
Positioning repeatability	±0.01mm
Lost motion	0.1mm or less
Base	Material: Aluminum with white alumite treatment
Allowable static moment	Ma direction 32.3Nm, Mb direction 46.2Nm, Mc direction 68.3Nm
Allowable dynamic moment (*1)	Ma direction 11.6Nm, Mb direction 16.6Nm, Mc direction 24.6Nm
Ambient operating temp. & humidity	0~40°C, 85% RH or less (Non-condensing)

(\*1) Assumes a standard rated life of 5000km. The service life will vary depending on operation and installation conditions. Please contact IAI for details of the running life.

### Allowable load moment directions

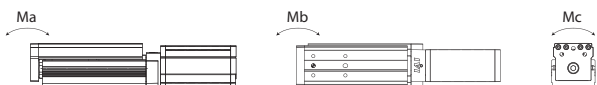

If the load moments in Ma/Mb/Mc direction are within the allowable ranges, there is no overhanging load length limit. Please refer to the RCS4 manual regarding the displacement of the table.

Round cable joint connector with screw locking (*1)	<b>EU</b>	See P.131
---	-----------	-----------



## Dimensions

CAD drawings can be downloaded from our website.

[www.robocylinder.de](http://www.robocylinder.de)



\*1 When the table is returning to its home position, please be mindful of possible interference from surrounding objects, as it will travel until it reaches the M.E.  
M.E: Mechanical end S.E: Stroke end

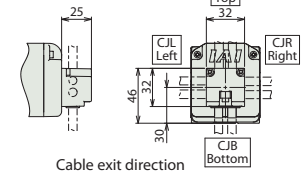
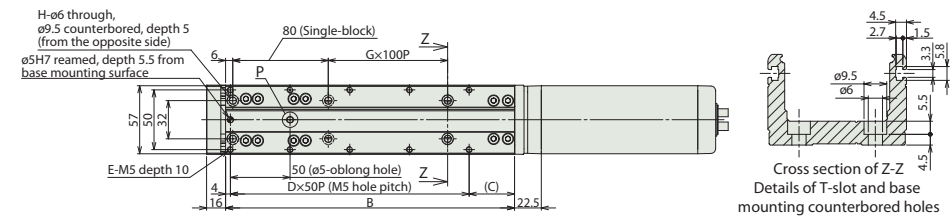
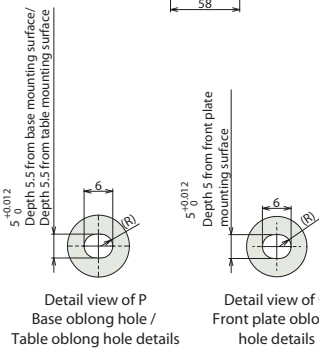
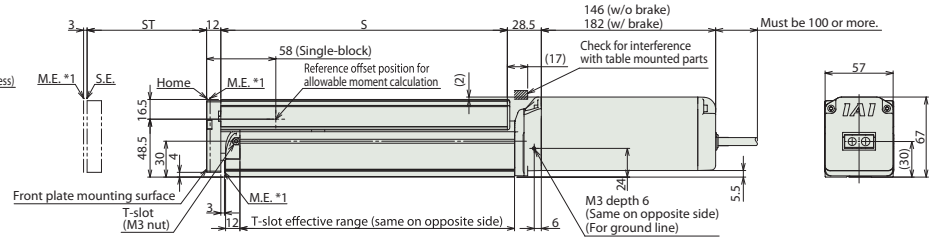
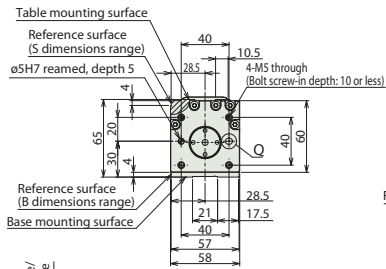
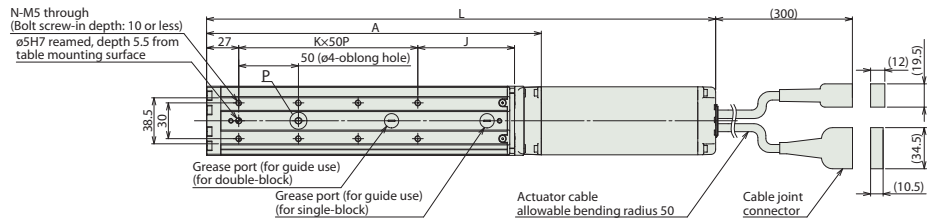
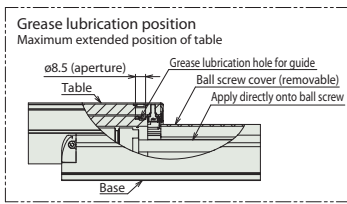

### Dimensions and Mass by Stroke

		25	50	75	100	125	150	175	200
L	W/o brake	301.5	326.5	351.5	376.5	401.5	426.5	451.5	476.5
	W/ brake	337.5	362.5	387.5	412.5	437.5	462.5	487.5	512.5
A		155.5	180.5	205.5	230.5	255.5	280.5	305.5	330.5
B		117	142	167	192	217	242	267	292
C		13	38	13	38	13	38	13	38
D		2	2	3	3	4	4	5	5
E		6	6	8	8	10	10	12	12
G		0	0	0	0	1	1	1	1
H		4	4	4	4	6	6	6	6
J		56	81	56	81	56	81	56	81
K		1	1	2	2	3	3	4	4
N		4	4	6	6	8	8	10	10
S		115	140	165	190	215	240	265	290
Mass (kg)	W/o brake	2.1	2.3	2.4	2.6	2.7	2.9	3.1	3.2
	W/ brake	2.4	2.6	2.7	2.9	3.0	3.2	3.4	3.5

### Applicable Controllers

The RCS4 series actuators can be operated by the controllers indicated below. Please select the type depending on your intended use.

Name	External view	Max. number of connectable axes	Input power	Control method				Maximum number of positioning points	Reference page	
				Positioner	Pulse train	Program	Network * Option			
SCON-CB/CGB		1	Single phase 115V/230VAC	●	●	—	DeviceNet CCLink PROFINET Compovet EtherCAT EtherNet/IP	512 (768 for network spec.)	Please see P.151	
SCON-LC/LCG (*)		1		—	—	●		512 (768 for network spec.)		
SCON-CAL/CGAL		1		●	—	—		512 (768 for network spec.)		
MSCON-C		6		This model is network-compatible only.				256		
SSEL-CS		2		●	—	●		20000		
XSEL-P/Q or XSEL-RA/SA (*)		6 or 8 (Depending on the type)	Single phase 230VAC Three-phase 230VAC	—	—	●	20000 or 55000 (Depending on the type)	Please see the dedicated controller catalog or manual.		
Note: The type of compatible networks will vary depending on the controller. Please refer to the reference page for more information.										

(\*) Coming soon

Foreword  
Slider Type  
Wide Slider Type  
Rod Type  
Radial Cylinder  
Wide Radial Cylinder  
Table Type  
Cleanroom Slider  
Cleanroom Wide Slider  
Options  
Reference Data  
Controller

# RCS4-TA6C□-DB <with Double-block Guide>

Battery-less Absolute
Motor Unit Coupled
Straight Motor
Body Width 60 mm
230v AC Servo Motor

Model Specification Items	<b>RCS4</b> — <b>TA6C</b> — <b>WA</b> — <b>100</b> — □ — □ — □ — <b>T2</b> — □ — <b>DB</b> — □
	Series — Type — Encoder Type — Motor Type — Lead — Stroke — Applicable Controllers — Cable Length — Options
	WA: Battery-less Absolute      100: Servo Motor 100W      12:12mm 6: 6mm 3: 3mm      45:45mm 320:320mm T2: SCON MSCON SSEL XSEL-P/Q XSEL-RA/SA      N : None P : 1m S : 3m M : 5m X□□ : Specified Length R□□ : Robot Cable Refer to Options table below.

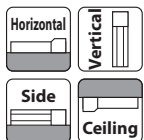

\* Depending on the model, there may be some limitations to using the vertical, side, and ceiling mount positions. Please refer to the Selection Notes on P.138 for more information.



- POINT Selection Notes**
- (1) Longer strokes may cause the maximum speed to decrease due to resonance of the ball screw. Be sure to check the maximum speed of the desired stroke in the Actuator Specifications table, which can be found below.
  - (2) Both the horizontal and vertical payloads assume operation at an acceleration of 0.3G.
  - (3) When the acceleration is increased, the payload will be reduced. Please refer to "Table of Payload by Acceleration" on P.139 for more details.
  - (4) Estimated allowable duty varies depending on operating conditions (payload, acceleration/deceleration, etc.). Please refer to P. 149 for more information.
  - (5) Please refer to the graphs shown on P.148 for the allowable load mass.

### Actuator Specifications

#### Lead and Payload

Model Number	Motor wattage (W)	Lead (mm)	Max. payload		Rated thrust (N)	Stroke (mm)
			Horizontal (kg)	Vertical (kg)		
RCS4-TA6C-WA-100-12-①-T2-②-DB-③	100	12	14	6	142	45~120 (25mm increments)
RCS4-TA6C-WA-100-6-①-T2-②-DB-③		6	20	10	283	170~320 (50mm increments)
RCS4-TA6C-WA-100-3-①-T2-②-DB-③		3	20	12	566	

Legend: ① Stroke ② Cable Length ③ Option

#### Stroke and Max Speed (Unit: mm/s)

Lead	Stroke	45~270 (mm)	320 (mm)
		12	720
6	360	285	
3	180	140	

### Cable Length

Type	Cable Code
Standard	P (1m)
	S (3m)
	M (5m)
Specified length (Standard cable)	X06 (6m) ~ X10 (10m)
	X11 (11m) ~ X15 (15m)
	X16 (16m) ~ X20 (20m)
	R01 (1m) ~ R03 (3m)
Robot cable	R04 (4m) ~ R05 (5m)
	R06 (6m) ~ R10 (10m)
	R11 (11m) ~ R15 (15m)
	R16 (16m) ~ R20 (20m)

### Actuator Specifications

Item	Description
Drive system	Ball screw ø10mm, rolled C10
Positioning repeatability	±0.01mm
Lost motion	0.1mm or less
Base	Material: Aluminum with white alumite treatment
Allowable static moment	Ma direction 169N·m, Mb direction 242N·m, Mc direction 137N·m
Allowable dynamic moment (*1)	Ma direction 49.5N·m, Mb direction 70.7N·m, Mc direction 40N·m
Ambient operating temp. & humidity	0~40°C, 85% RH or less (Non-condensing)

(\*1) Assumes a standard rated life of 5000km. The service life will vary depending on operation and installation conditions. Please contact IAI for details of the running life.

#### Allowable load moment directions



If the load moments in Ma/Mb/Mc direction are within the allowable ranges, there is no overhang load length limit. Please refer to the RCS4 manual regarding the displacement of the table.

Round cable joint connector with screw locking (*1)	<b>EU</b>	See P.131
---	-----------	-----------

### Options

Name	Option Code	Reference Page
Brake	<b>B</b>	See P.131
Cable exit direction (Top)	<b>CJT</b>	See P.131
Cable exit direction (Right)	<b>CJR</b>	See P.131
Cable exit direction (Left)	<b>CJL</b>	See P.131
Cable exit direction (Bottom)	<b>CJB</b>	See P.131
Non-motor end specification	<b>NM</b>	See P.136

(\*1) EU option will be available soon.

## Dimensions

CAD drawings can be downloaded from our website.

www.robocylinder.de



\*1 When the table is returning to its home position, please be mindful of possible interference from surrounding objects, as it will travel until it reaches the M.E.  
M.E: Mechanical end S.E: Stroke end

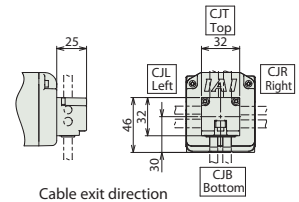
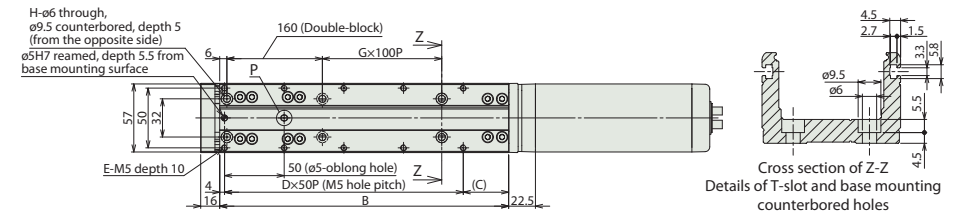
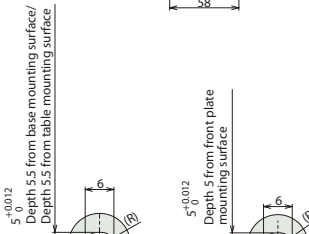
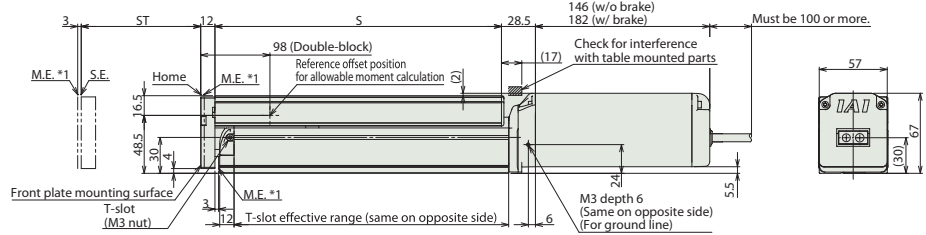
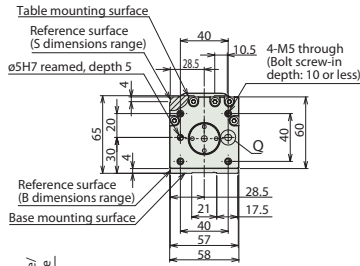
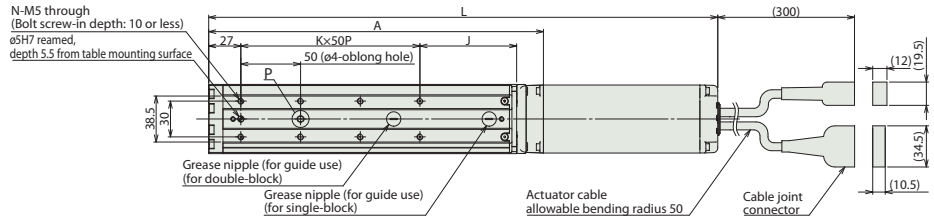
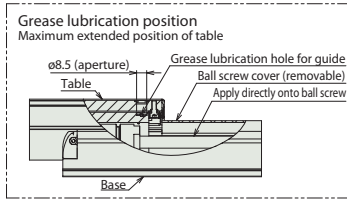

### Dimensions and Mass by Stroke

L	ST	45	70	95	120	170	220	270	320
		W/o brake	401.5	426.5	451.5	476.5	526.5	576.5	626.5
	W/ brake	437.5	462.5	487.5	512.5	562.5	612.5	662.5	712.5
	A	255.5	280.5	305.5	330.5	380.5	430.5	480.5	530.5
	B	217	242	267	292	342	392	442	492
	C	13	38	13	38	38	38	38	38
	D	4	4	5	5	6	7	8	9
	E	10	10	12	12	14	16	18	20
	G	0	0	0	0	1	1	2	2
	H	4	4	4	4	6	6	8	8
	J	56	81	56	81	81	81	81	81
	K	3	3	4	4	5	6	7	8
	N	8	8	10	10	12	14	16	18
	S	215	240	265	290	340	390	440	490
Mass (kg)	W/o brake	2.9	3.1	3.3	3.4	3.7	4.1	4.4	4.7
	W/ brake	3.2	3.4	3.6	3.7	4	4.4	4.7	5

### Applicable Controllers

The RCS4 series actuators can be operated by the controllers indicated below. Please select the type depending on your intended use.

Name	External view	Max. number of connectable axes	Input power	Control method				Maximum number of positioning points	Reference page
				Positioner	Pulse train	Program	Network * Option		
SCON-CB/CGB		1	Single phase 115V/230VAC	●	●	—	DeviceNet CCLink PROFINET CompoNet EtherCAT EtherNet/IP	512 (768 for network spec.)	Please see the dedicated controller catalog or manual.
SCON-LC/LCG (*)		1		—	—	●		512 (768 for network spec.)	
SCON-CAL/CGAL		1		●	—	—		512 (768 for network spec.)	
MSCON-C		6		This model is network-compatible only.				256	
SSEL-CS		2		●	—	●	20000		
XSEL-P/Q or XSEL-RA/SA (*)		6 or 8 (Depending on the type)	Single phase 230VAC Three-phase 230VAC	—	—	●	20000 or 55000 (Depending on the type)		

(\*) Coming soon

Foreword  
Slider Type  
Wide Slider Type  
Rod Type  
Radial Cylinder  
Wide Radial Cylinder  
Table Type  
Cleanroom Slider  
Cleanroom Wide Slider  
Options  
Reference Data  
Controller

# RCS4-TA7C <with Single-block Guide>

Battery-less Absolute
Motor Unit Coupled
Straight Motor
Body Width 70 mm
230v AC Servo Motor

Model Specification Items	<b>RCS4</b> — <b>TA7C</b> — <b>WA</b> — <b>200</b> — [ ] — [ ] — [ ]	<b>T2</b> — [ ] — [ ]					
	Series — Type — Encoder Type — Motor Type — Lead — Stroke — Applicable Controllers — Cable Length — Options						
	WA: Battery-less Absolute	200: Servo motor 200W	24:24mm 16:16mm 8: 8mm 4: 4mm	25:25mm 300:300mm	T2:SCON MSCON SSEL XSEL-P/Q XSEL-RA/SA	N : None P : 1m S : 3m M : 5m X□□ : Specified Length R□□ : Robot Cable	Refer to Options table below.

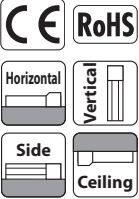

\* Depending on the model, there may be some limitations to using the vertical, side, and ceiling mount positions. Please refer to the Selection Notes on P.138 for more information.



**POINT Selection Notes**

- Both the horizontal and vertical payloads assume operation at an acceleration of 0.3G.
- When the acceleration is increased, the payload will be reduced. Please refer to "Table of Payload by Acceleration" on P.139 for more details.
- Estimated allowable duty varies depending on operating conditions (payload, acceleration/deceleration, etc.). Please refer to P. 149 for more information.
- Please refer to the graphs shown on P.148 for the allowable load mass.

## Actuator Specifications

### Lead and Payload

Model Number	Motor wattage (W)	Lead (mm)	Max. payload		Rated thrust (N)	Stroke (mm)
			Horizontal (kg)	Vertical (kg)		
RCS4-TA7C-WA-200-24-①-T2-②-③	200	24	12	5	142	25~200 (25mm increments) 250~300 (50mm increments)
RCS4-TA7C-WA-200-16-①-T2-②-③		16	15	10	214	
RCS4-TA7C-WA-200-8-①-T2-②-③		8	15	18	427	
RCS4-TA7C-WA-200-4-①-T2-②-③		4	15	20	855	

Legend: ① Stroke ② Cable Length ③ Option

### Stroke and Max Speed (Unit: mm/s)

Lead	Stroke	25~300 (mm)
	24	
16		960
8		480
4		240

## Cable Length

Type	Cable Code
Standard	P (1m)
	S (3m)
	M (5m)
Specified length (Standard cable)	X06 (6m) ~ X10 (10m)
	X11 (11m) ~ X15 (15m)
	X16 (16m) ~ X20 (20m)
	R01 (1m) ~ R03 (3m)
Robot cable	R04 (4m) ~ R05 (5m)
	R06 (6m) ~ R10 (10m)
	R11 (11m) ~ R15 (15m)
	R16 (16m) ~ R20 (20m)
	R16 (16m) ~ R20 (20m)

## Options

Name	Option Code	Reference Page
Brake	B	See P.131
Cable exit direction (Top)	CJT	See P.131
Cable exit direction (Right)	CJR	See P.131
Cable exit direction (Left)	CJL	See P.131
Cable exit direction (Bottom)	CJB	See P.131
Non-motor end specification	NM	See P.136

(\*1) EU option will be available soon.

## Actuator Specifications

Item	Description
Drive system	Ball screw ø12mm, rolled C10
Positioning repeatability	±0.01mm
Lost motion	0.1mm or less
Base	Material: Aluminum with white alumite treatment
Allowable static moment	Ma direction 115N·m, Mb direction 115N·m, Mc direction 229N·m
Allowable dynamic moment (*1)	Ma direction 44.7N·m, Mb direction 44.7N·m, Mc direction 89.1N·m
Ambient operating temp. & humidity	0~40°C, 85% RH or less (Non-condensing)

(\*1) Assumes a standard rated life of 5000km. The service life will vary depending on operation and installation conditions. Please contact IAI for details of the running life.

### Allowable load moment directions

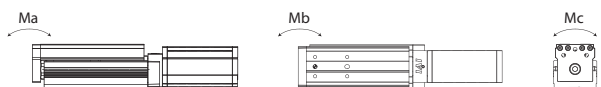

If the load moments in Ma/Mb/Mc direction are within the allowable ranges, there is no overhang load length limit. Please refer to the RCS4 manual regarding the displacement of the table.

Round cable joint connector with screw locking (*1)	EU	See P.131
---	----	-----------

## Dimensions

CAD drawings can be downloaded from our website.  
www.robocylinder.de



\*1 When the table is returning to its home position, please be mindful of possible interference from surrounding objects, as it will travel until it reaches the M.E.  
M.E: Mechanical end S.E: Stroke end

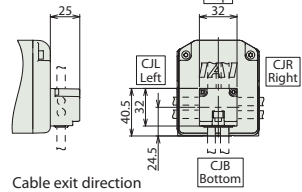
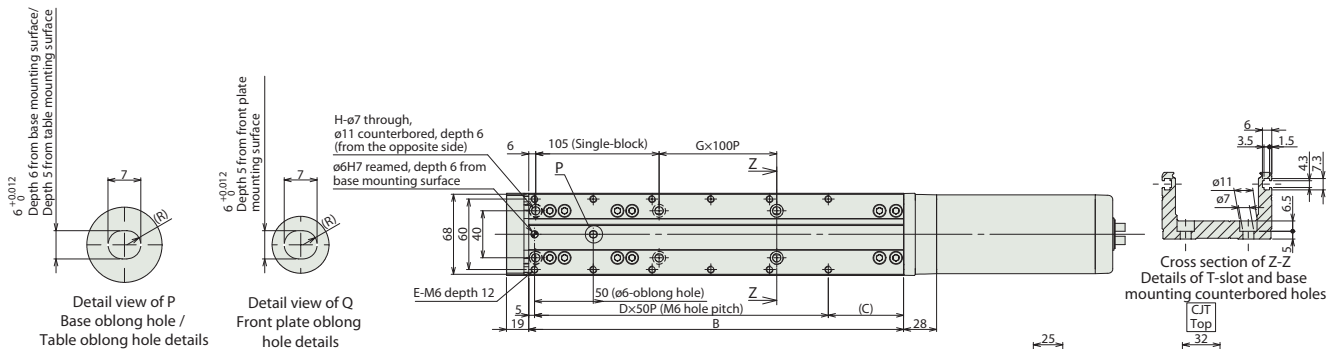
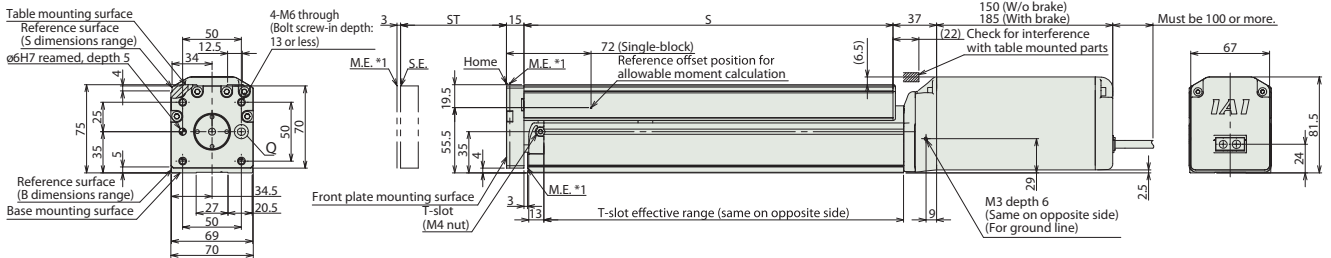
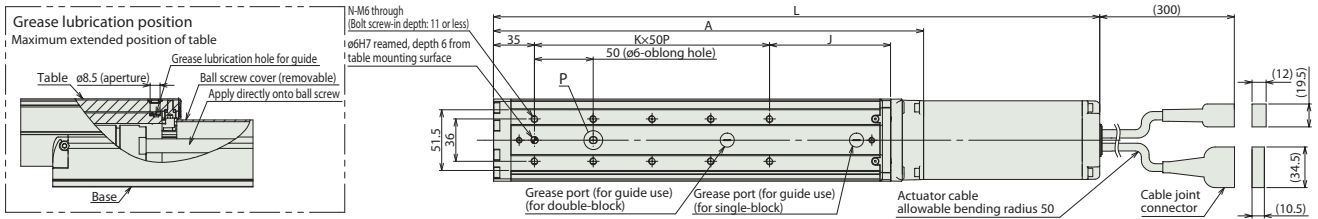

### Dimensions and Mass by Stroke

L	ST	25	50	75	100	125	150	175	200	250	300
		W/o brake	341	366	391	416	441	466	491	516	566
	W/ brake	376	401	426	451	476	501	526	551	601	651
	A	191	216	241	266	291	316	341	366	416	466
	B	144	169	194	219	244	269	294	319	369	419
	C	39	64	39	64	39	64	39	64	64	64
	D	2	2	3	3	4	4	5	5	6	7
	E	6	6	8	8	10	10	12	12	14	16
	G	0	0	0	0	1	1	1	1	2	2
	H	4	4	4	4	6	6	6	6	8	8
	J	78	103	78	103	78	103	78	103	103	103
	K	1	1	2	2	3	3	4	4	5	6
	N	4	4	6	6	8	8	10	10	12	14
	S	139	164	189	214	239	264	289	314	364	414
Mass (kg)	W/o brake	3.8	4.0	4.2	4.5	4.7	4.9	5.1	5.4	5.8	6.3
	W/ brake	4.3	4.5	4.7	5.0	5.2	5.4	5.6	5.9	6.3	6.8

### Applicable Controllers

The RCS4 series actuators can be operated by the controllers indicated below. Please select the type depending on your intended use.

Name	External view	Max. number of connectable axes	Input power	Control method				Maximum number of positioning points	Reference page	
				Positioner	Pulse train	Program	Network * Option			
SCON-CB/CGB		1	Single phase 115V/230VAC	●	●	—	DeviceNet CC-Link CANopen EtherCAT EtherNet/IP	512 (768 for network spec.)	Please see P.151	
SCON-LC/LCG (*)		1		—	—	●		512 (768 for network spec.)		
SCON-CAL/CGAL		1		●	—	—		512 (768 for network spec.)		
MSCON-C		6		This model is network-compatible only.				256		
SSEL-CS		2		●	—	●		20000		
XSEL-P/Q or XSEL-RA/SA (*)		6 or 8 (Depending on the type)		Single phase 230VAC Three-phase 230VAC	—	—	●	20000 or 55000 (Depending on the type)		

Note: The type of compatible networks will vary depending on the controller. Please refer to the reference page for more information.

(\*) Coming soon

Foreword  
Slider Type  
Wide Slider Type  
Rod Type  
Radial Cylinder®  
Wide Radial Cylinder  
Table Type  
Cleanroom Slider  
Cleanroom Wide Slider  
Options  
Reference Data  
Controller

# RCS4-TA7C□-DB <with Double-block Guide>

Battery-less Absolute Motor Unit Coupled Straight Motor Body Width 70mm 230v AC Servo Motor

Model Specification Items	<b>RCS4</b> — <b>TA7C</b> — <b>WA</b> — <b>200</b> — □ — □ — □ — <b>T2</b> — □ — <b>DB</b> — □
	Series — Type — Encoder Type — Motor Type — Lead — Stroke — Applicable Controllers — Cable Length — Options
	WA: Battery-less Absolute      200: Servo motor 200W      16:16mm 8: 8mm 4: 4mm      40:40mm 390:390mm      T2:SCON MSCON SSEL XSEL-P/Q XSEL-RA/SA      N : None P : 1m S : 3m M : 5m X□□ : Specified Length R□□ : Robot Cable      Refer to Options table below.

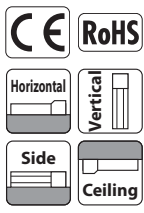

\* Depending on the model, there may be some limitations to using the vertical, side, and ceiling mount positions. Please refer to the Selection Notes on P.138 for more information.



**POINT Selection Notes**

- (1) Longer strokes may cause the maximum speed to decrease due to resonance of the ball screw. Be sure to check the maximum speed of the desired stroke in the Actuator Specifications table, which can be found below.
- (2) Both the horizontal and vertical payloads assume operation at an acceleration of 0.3G.
- (3) When the acceleration is increased, the payload will be reduced. Please refer to "Table of Payload by Acceleration" on P.139 for more details.
- (4) Estimated allowable duty varies depending on operating conditions (payload, acceleration/deceleration, etc.). Please refer to P. 149 for more information.
- (5) Please refer to the graphs shown on P.148 for the allowable load mass.

Actuator Specifications						
Lead and Payload						
Model Number	Motor wattage (W)	Lead (mm)	Max. payload		Rated thrust (N)	Stroke (mm)
			Horizontal (kg)	Vertical (kg)		
RCS4-TA7C-WA-200-16-①-T2-②-DB-③	200	16	25	8	214	40~90 (25mm increments) 140~390 (50mm increments)
RCS4-TA7C-WA-200-8-①-T2-②-DB-③		8	30	18	427	
RCS4-TA7C-WA-200-4-①-T2-②-DB-③		4	30	24	855	

Legend: ① Stroke ② Cable Length ③ Option

Stroke and Max Speed (Unit: mm/s)				
Lead	Stroke	40~290 (mm)	340	390
		16	960	730
8	480	365	300	
4	240	180	150	

Cable Length	
Type	Cable Code
Standard	P (1m)
	S (3m)
	M (5m)
Specified length (Standard cable)	X06 (6m) ~ X10 (10m)
	X11 (11m) ~ X15 (15m)
	X16 (16m) ~ X20 (20m)
	R01 (1m) ~ R03 (3m)
Robot cable	R04 (4m) ~ R05 (5m)
	R06 (6m) ~ R10 (10m)
	R11 (11m) ~ R15 (15m)
	R16 (16m) ~ R20 (20m)

Actuator Specifications	
Item	Description
Drive system	Ball screw ø12mm, rolled C10
Positioning repeatability	±0.01mm
Lost motion	0.1mm or less
Base	Material: Aluminum with white alumite treatment
Allowable static moment	Ma direction 620N·m, Mb direction 620N·m, Mc direction 458N·m
Allowable dynamic moment (*1)	Ma direction 196N·m, Mb direction 196N·m, Mc direction 145N·m
Ambient operating temp. & humidity	0~40°C, 85% RH or less (Non-condensing)

(\*1) Assumes a standard rated life of 5000km. The service life will vary depending on operation and installation conditions. Please contact IAI for details of the running life.

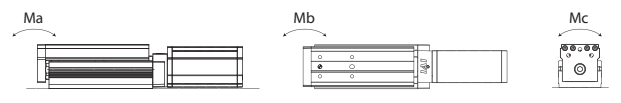

If the load moments in Ma/Mb/Mc direction are within the allowable ranges, there is no overhang load length limit. Please refer to the RCS4 manual regarding the displacement of the table.

Options		
Name	Option Code	Reference Page
Brake	<b>B</b>	See P.131
Cable exit direction (Top)	<b>CJT</b>	See P.131
Cable exit direction (Right)	<b>CJR</b>	See P.131
Cable exit direction (Left)	<b>CJL</b>	See P.131
Cable exit direction (Bottom)	<b>CJB</b>	See P.131
Non-motor end specification	<b>NM</b>	See P.136

Round cable joint connector with screw locking (*1)	<b>EU</b>	See P.131
---	-----------	-----------

(\*1) EU option will be available soon.



# RCS4-TA4R <with Single-block Guide>

Battery-less Absolute
Motor Unit Coupled
Side-mounted Motor
Body Width 40\* mm
230v AC Servo Motor

■ Model Specification Items	<b>RCS4</b> — <b>TA4R</b> — <b>WA</b> — <b>60</b> — [ ] — [ ] — <b>T2</b> — [ ] — [ ]	* Body width does not include the width of the side-mounted motor.
	Series — Type — Encoder Type — Motor Type — Lead — Stroke — Applicable Controllers — Cable Length — Options WA: Battery-less Absolute    60: Servo motor 60W    16: 16mm 10: 10mm 5: 5mm 2.5: 2.5mm    25: 25mm 150: 150mm (25mm increments)    T2: SCON MSCON SSEL XSEL-P/Q XSEL-RA/SA    N: None P: 1m S: 3m M: 5m    Refer to Options table below.    X□□: Specified Length R□□: Robot Cable	

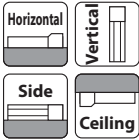

\* Depending on the model, there may be some limitations to using the vertical, side, and ceiling mount positions. Please refer to the Selection Notes on P.138 for more information.



**POINT Selection Notes**

- Both the horizontal and vertical payloads assume operation at an acceleration of 0.3G.
- When the acceleration is increased, the payload will be reduced. Please refer to "Table of Payload by Acceleration" on P.139 for more details.
- Estimated allowable duty varies depending on operating conditions (payload, acceleration/deceleration, etc.). Please refer to P. 149 for more information.
- Please refer to the graphs shown on P.148 for the allowable load mass.

## Actuator Specifications

### Lead and Payload

Model Number	Motor wattage (W)	Lead (mm)	Max. payload		Rated thrust (N)	Stroke (mm)
			Horizontal (kg)	Vertical (kg)		
RCS4-TA4R-WA-60-16-①-T2-②-③	60	16	4	1.5	53	25~150 (25mm increments)
RCS4-TA4R-WA-60-10-①-T2-②-③		10	5	3	85	
RCS4-TA4R-WA-60-5-①-T2-②-③		5	5	6	170	
RCS4-TA4R-WA-60-2.5-①-T2-②-③		2.5	5	9	340	

Legend: ① Stroke ② Cable Length ③ Option

### Stroke and Max Speed (Unit: mm/s)

Lead	Stroke	
	25~150 (mm)	25~150 (mm)
16	800	
10	600	
5	300	
2.5	150	

## Cable Length

Type	Cable Code
Standard	P (1m)
	S (3m)
	M (5m)
Specified length (Standard cable)	X06 (6m) ~ X10 (10m)
	X11 (11m) ~ X15 (15m)
	X16 (16m) ~ X20 (20m)
	R01 (1m) ~ R03 (3m)
Robot cable	R04 (4m) ~ R05 (5m)
	R06 (6m) ~ R10 (10m)
	R11 (11m) ~ R15 (15m)
	R16 (16m) ~ R20 (20m)
	R16 (16m) ~ R20 (20m)

## Actuator Specifications

Item	Description
Drive system	Ball screw ø8mm, rolled C10
Positioning repeatability	±0.01mm
Lost motion	0.1mm or less
Base	Material: Aluminum with white alumite treatment
Allowable static moment	Ma direction 13N·m, Mb direction 18.6N·m, Mc direction 25.3N·m
Allowable dynamic moment (*1)	Ma direction 4.98N·m, Mb direction 7.11N·m, Mc direction 9.68N·m
Ambient operating temp. & humidity	0~40°C, 85% RH or less (Non-condensing)

(\*1) Assumes a standard rated life of 5000km. The service life will vary depending on operation and installation conditions. Please contact IAI for details of the running life.

Allowable load moment directions

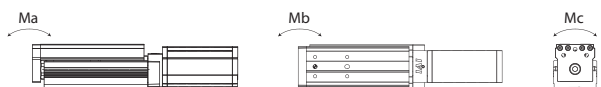

If the load moments in Ma/Mb/Mc direction are within the allowable ranges, there is no overhang load length limit. Please refer to the RCS4 manual regarding the displacement of the table.

## Options

Name	Option Code	Reference Page
Brake	B	See P.131
Cable exit direction (Top)	CJT	See P.131
Cable exit direction (Bottom)	CJB	See P.131
Cable exit direction (Outside)	CJO	See P.131
Motor side-mounted to left (standard)	ML	See P.135
Motor side-mounted to right	MR	See P.135
Non-motor end specification	NM	See P.136
Back mounting plate	RP	See P.137

(\*1) EU option will be available soon.

Round cable joint connector with screw locking (*1)	EU	See P.131
---	----	-----------



## Dimensions

CAD drawings can be downloaded from our website.

www.robocylinder.de



\*1 When the table is returning to its home position, please be mindful of possible interference from surrounding objects, as it will travel until it reaches the M.E.  
M.E: Mechanical end S.E: Stroke end

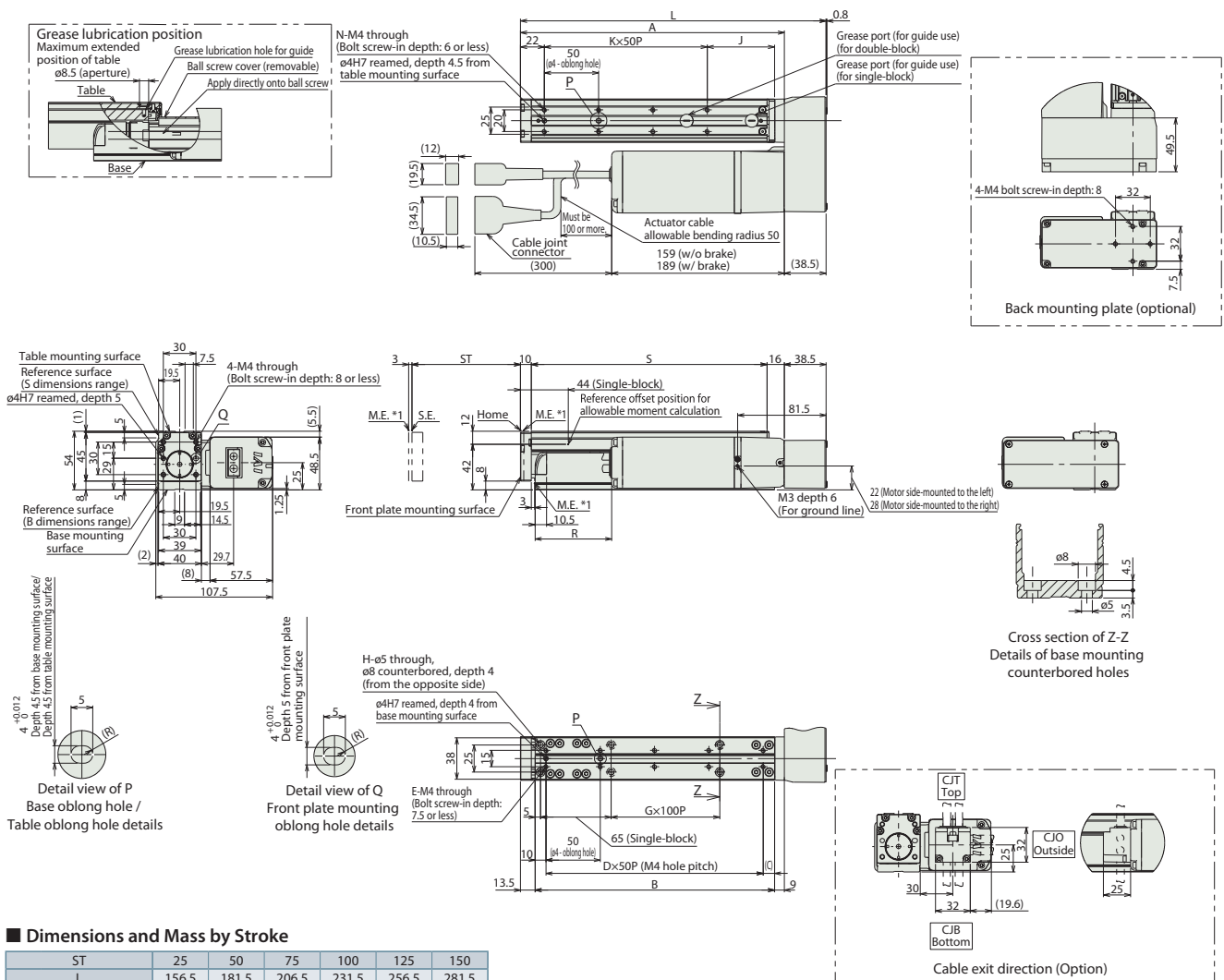

### Dimensions and Mass by Stroke

	ST	25	50	75	100	125	150
L	156.5	181.5	206.5	231.5	256.5	281.5	
A	118	143	168	193	218	243	
B	95.5	120.5	145.5	170.5	195.5	220.5	
C	35.5	10.5	35.5	10.5	35.5	10.5	
D	1	2	2	3	3	4	
E	4	6	6	8	8	10	
G	0	0	0	0	1	1	
H	4	4	4	4	6	6	
J	37	62	37	62	37	62	
K	1	1	2	2	3	3	
N	4	4	6	6	8	8	
R (Note)	W/o brake	-54.5	-29.5	-4.5	20.5	45.5	70.5
	W/ brake	-84.5	-59.5	-34.5	-9.5	15.5	40.5
	S	92	117	142	167	192	217
Mass (kg)	W/o brake	1.5	1.6	1.7	1.8	1.9	2.0
	W/ brake	1.8	1.9	2.0	2.1	2.2	2.3

(Note) If the length for R is negative, the length of the actuator body is shorter than the motor unit.

### Applicable Controllers

The RCS4 series actuators can be operated by the controllers indicated below. Please select the type depending on your intended use.

Name	External view	Max. number of connectable axes	Input power	Control method				Maximum number of positioning points	Reference page
				Positioner	Pulse train	Program	Network * Option		
SCON-CB/CGB		1	Single phase 115V/230VAC	●	●	—	DeviceNet CC-Link PROFINET CompoNet EtherCAT EtherNet/IP	512 (768 for network spec.)	Please see P.151
SCON-LC/LCG (*)		1		—	—	●		512 (768 for network spec.)	
SCON-CAL/CGAL		1		●	—	—		512 (768 for network spec.)	
MSCON-C		6		This model is network-compatible only.				256	
SSEL-CS		2		●	—	●	20000		
XSEL-P/Q or XSEL-RA/SA (*)		6 or 8 (Depending on the type)		Single phase 230VAC Three-phase 230VAC	—	—	●	20000 or 55000 (Depending on the type)	

Note: The type of compatible networks will vary depending on the controller. Please refer to the reference page for more information.

(\*) Coming soon

Foreword  
Slider Type  
Wide Slider Type  
Rod Type  
Radial Cylinder  
Wide Radial Cylinder  
Table Type  
Cleanroom Slider  
Cleanroom Wide Slider  
Options  
Reference Data  
Controller



## Dimensions

CAD drawings can be downloaded from our website.

[www.robocylinder.de](http://www.robocylinder.de)



\*1 When the table is returning to its home position, please be mindful of possible interference from surrounding objects, as it will travel until it reaches the M.E.  
M.E: Mechanical end S.E: Stroke end

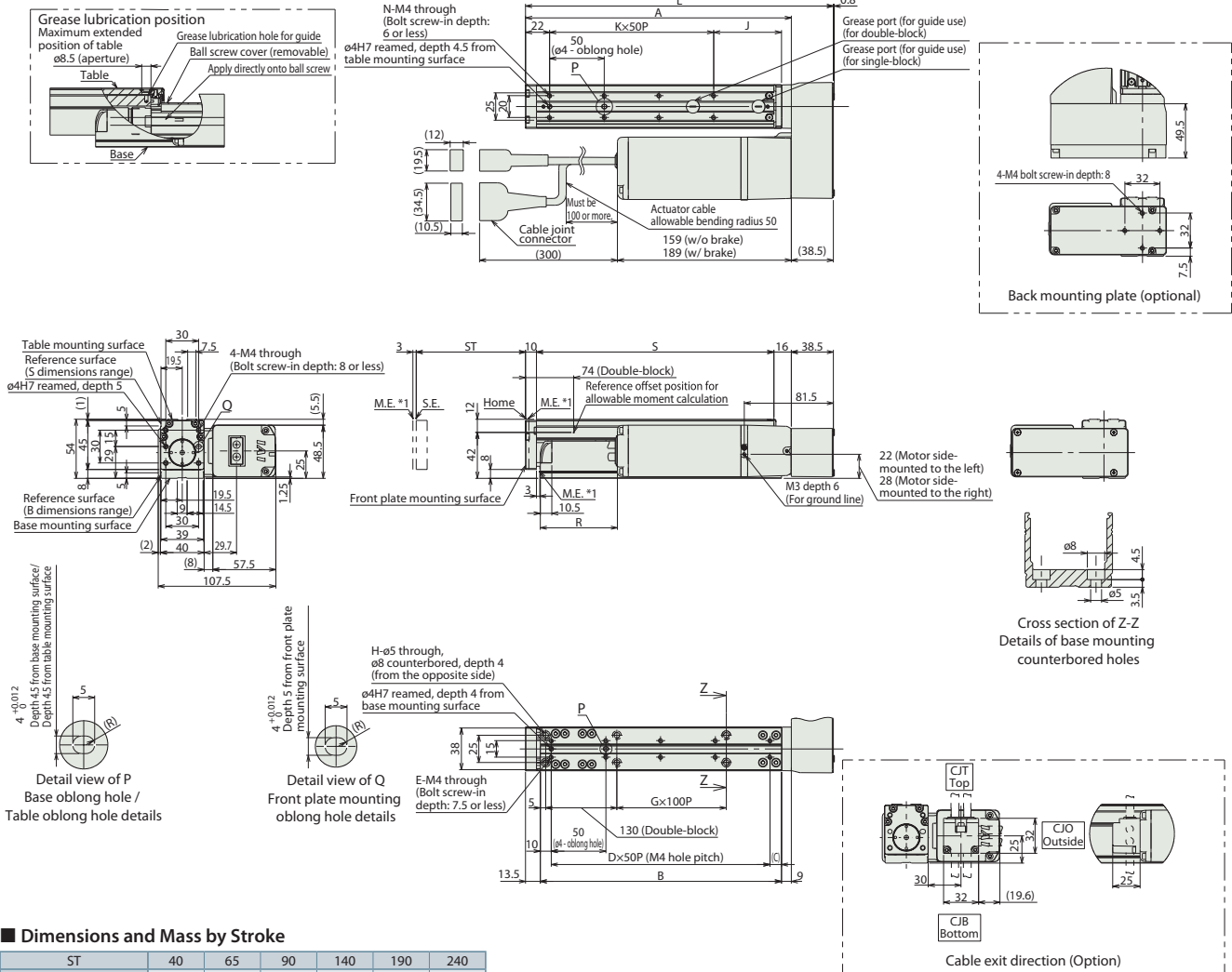

### ■ Dimensions and Mass by Stroke

	ST	40	65	90	140	190	240
L	231.5	256.5	281.5	331.5	381.5	431.5	
A	193	218	243	293	343	393	
B	170.5	195.5	220.5	270.5	320.5	370.5	
C	10.5	35.5	10.5	10.5	10.5	10.5	
D	3	3	4	5	6	7	
E	8	8	10	12	14	16	
G	0	0	0	1	1	2	
H	4	4	4	6	6	8	
J	62	37	62	62	62	62	
K	2	3	3	4	5	6	
N	6	8	8	10	12	14	
R (Note)	W/o brake	20.5	45.5	70.5	120.5	170.5	220.5
	W/ brake	-9.5	15.5	40.5	90.5	140.5	190.5
	S	167	192	217	267	317	367
Mass (kg)	W/o brake	1.9	2.0	2.1	2.3	2.4	2.6
	W/ brake	2.2	2.3	2.4	2.6	2.7	2.9

(Note) If the length for R is negative, the length of the actuator body is shorter than the motor unit.

### Applicable Controllers

The RCS4 series actuators can be operated by the controllers indicated below. Please select the type depending on your intended use.

Name	External view	Max. number of connectable axes	Input power	Control method				Maximum number of positioning points	Reference page	
				Positioner	Pulse train	Program	Network * Option			
SCON-CB/CGB		1	Single phase 115V/230VAC	●	●	—	DeviceNet CC-Link CANopen EtherCAT EtherNet/IP Note: The type of compatible networks will vary depending on the controller. Please refer to the reference page for more information.	512 (768 for network spec.)	Please see P.151	
SCON-LC/LCG (*)		1		—	—	●		512 (768 for network spec.)		
SCON-CAL/CGAL		1		●	—	—		512 (768 for network spec.)		
MSCON-C		6		This model is network-compatible only.				256		
SSEL-CS		2		●	—	●		20000		
XSEL-P/Q or XSEL-RA/SA (*)		6 or 8 (Depending on the type)	Single phase 230VAC Three-phase 230VAC	—	—	●	20000 or 55000 (Depending on the type)	Please see the dedicated controller catalog or manual.		
(*) Coming soon										

Foreword  
Slider Type  
Wide Slider Type  
Rod Type  
Radial Cylinder  
Wide Radial Cylinder  
Table Type  
Cleanroom Slider  
Cleanroom Wide Slider  
Options  
Reference Data  
Controller

# RCS4-TA6R <with Single-block Guide>

Battery-less Absolute
Motor Unit Coupled
Side-mounted Motor
Body Width 60\* mm
230v AC Servo Motor

Model Specification Items	<b>RCS4</b>	<b>TA6R</b>	<b>WA</b>	<b>100</b>			<b>T2</b>			* Body width does not include the width of the side-mounted motor.
	Series	Type	Encoder Type	Motor Type	Lead	Stroke	Applicable Controllers	Cable Length	Options	
	WA: Battery-less Absolute	100: Servo motor 100W			20:20mm 12:12mm 6: 6mm 3: 3mm	25:25mm + 200:200mm (25mm increments)	T2:SCON MSCON SSEL XSEL-P/Q XSEL-RA/SA	N : None P : 1m S : 3m M : 5m X□□ : Specified Length R□□ : Robot Cable	Refer to Options table below.	



\* Depending on the model, there may be some limitations to using the vertical, side, and ceiling mount positions. Please refer to the Selection Notes on P.138 for more information.

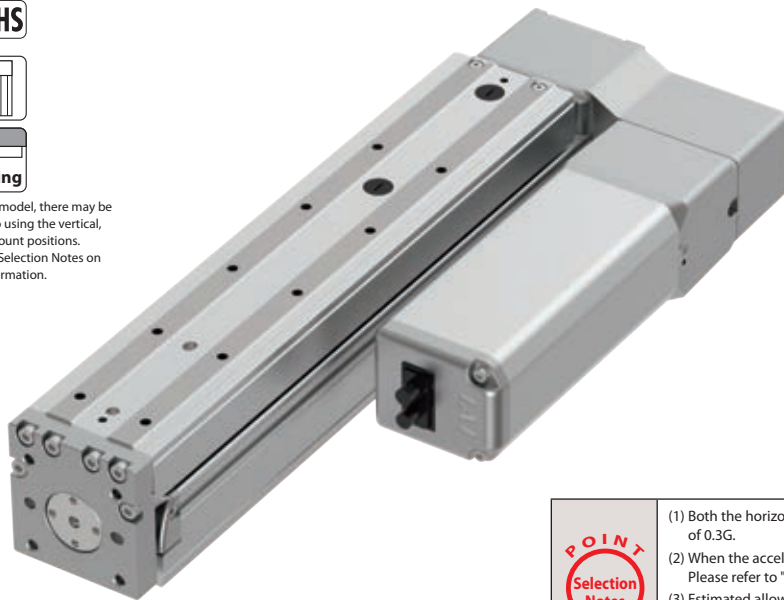

**POINT Selection Notes**

- Both the horizontal and vertical payloads assume operation at an acceleration of 0.3G.
- When the acceleration is increased, the payload will be reduced. Please refer to "Table of Payload by Acceleration" on P.139 for more details.
- Estimated allowable duty varies depending on operating conditions (payload, acceleration/deceleration, etc.). Please refer to P. 149 for more information.
- Please refer to the graphs shown on P.148 for the allowable load mass.

## Actuator Specifications

### Lead and Payload

Model Number	Motor wattage (W)	Lead (mm)	Max. payload		Rated thrust (N)	Stroke (mm)
			Horizontal (kg)	Vertical (kg)		
RCS4-TA6R-WA-100-20-①-T2-②-③	100	20	8	4	85	25~200 (25mm increments)
RCS4-TA6R-WA-100-12-①-T2-②-③		12	8	6	142	
RCS4-TA6R-WA-100-6-①-T2-②-③		6	8	10	283	
RCS4-TA6R-WA-100-3-①-T2-②-③		3	10	10	566	

Legend: ① Stroke ② Cable Length ③ Option

### Stroke and Max Speed (Unit: mm/s)

Lead	Stroke	25~200
		(mm)
20		1000
12		720
6		360
3		180

## Cable Length

Type	Cable Code
Standard	P (1m)
	S (3m)
	M (5m)
Specified length (Standard cable)	X06 (6m) ~ X10 (10m)
	X11 (11m) ~ X15 (15m)
	X16 (16m) ~ X20 (20m)
	R01 (1m) ~ R03 (3m)
Robot cable	R04 (4m) ~ R05 (5m)
	R06 (6m) ~ R10 (10m)
	R11 (11m) ~ R15 (15m)
	R16 (16m) ~ R20 (20m)
	R16 (16m) ~ R20 (20m)

## Actuator Specifications

Item	Description
Drive system	Ball screw ø10mm, rolled C10
Positioning repeatability	±0.01mm
Lost motion	0.1mm or less
Base	Material: Aluminum with white alumite treatment
Allowable static moment	Ma direction 32.3N·m, Mb direction 46.2N·m, Mc direction 68.3N·m
Allowable dynamic moment (*1)	Ma direction 11.6N·m, Mb direction 16.6N·m, Mc direction 24.6N·m
Ambient operating temp. & humidity	0~40°C, 85% RH or less (Non-condensing)

(\*1) Assumes a standard rated life of 5000km. The service life will vary depending on operation and installation conditions. Please contact IAI for details of the running life.

### Allowable load moment directions

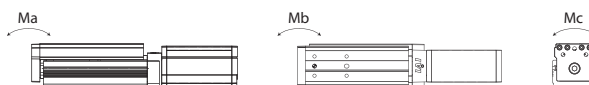

If the load moments in Ma/Mb/Mc direction are within the allowable ranges, there is no overhang load length limit.

Please refer to the RCS4 manual regarding the displacement of the table.

Round cable joint connector with screw locking (*1)	<b>EU</b>	See P.131
---	-----------	-----------

## Options

Name	Option Code	Reference Page
Brake	<b>B</b>	See P.131
Cable exit direction (Top)	<b>CJT</b>	See P.131
Cable exit direction (Bottom)	<b>CJB</b>	See P.131
Cable exit direction (Outside)	<b>CJO</b>	See P.131
Motor side-mounted to left (standard)	<b>ML</b>	See P.135
Motor side-mounted to right	<b>MR</b>	See P.135
Non-motor end specification	<b>NM</b>	See P.136

(\*1) EU option will be available soon.

## Dimensions

CAD drawings can be downloaded from our website.

www.robocylinder.de



\*1 When the table is returning to its home position, please be mindful of possible interference from surrounding objects, as it will travel until it reaches the M.E.  
M.E: Mechanical end S.E: Stroke end

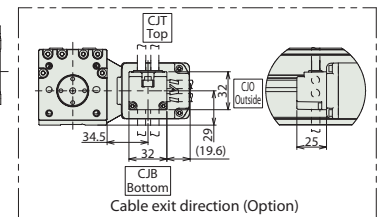
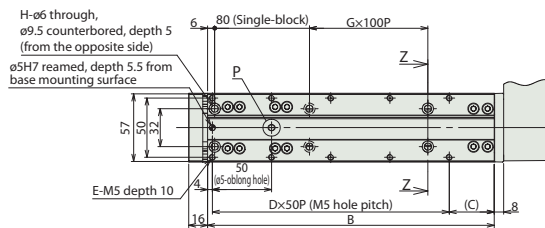
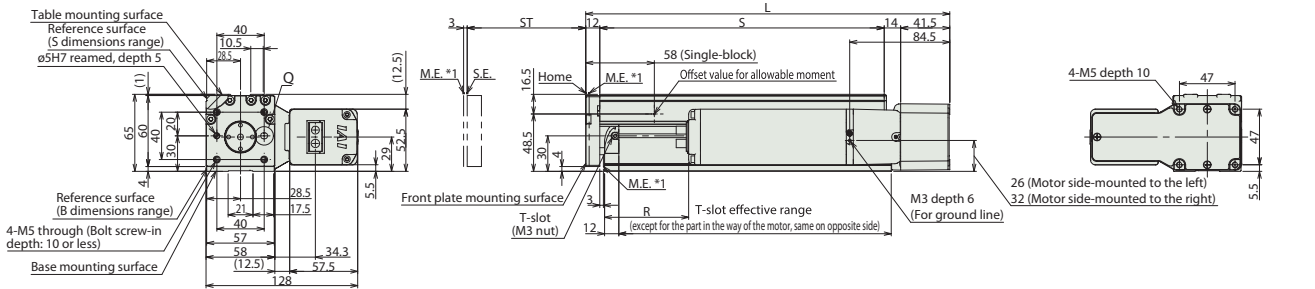
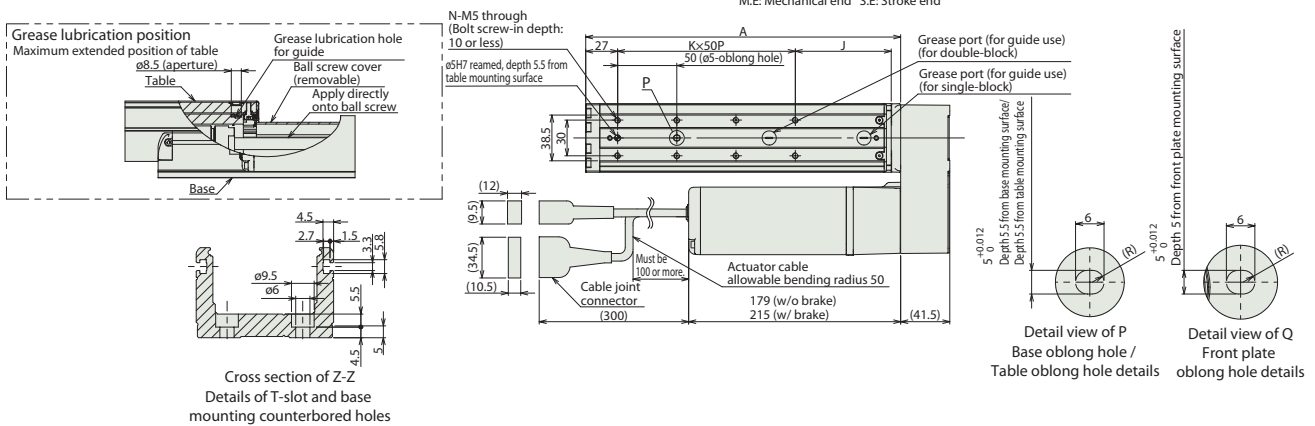

### Dimensions and Mass by Stroke

	ST	25	50	75	100	125	150	175	200
L	182.5	207.5	232.5	257.5	282.5	307.5	332.5	357.5	
A	141	166	191	216	241	266	291	316	
B	117	142	167	192	217	242	267	292	
C	13	38	13	38	13	38	13	38	
D	2	2	3	3	4	4	5	5	
E	6	6	8	8	10	10	12	12	
G	0	0	0	0	1	1	1	1	
H	4	4	4	4	6	6	6	6	
J	56	81	56	81	56	81	56	81	
K	1	1	2	2	3	3	4	4	
N	4	4	6	6	8	8	10	10	
R (Note)	W/o brake	-54	-29	-4	21	46	71	96	121
	W/ brake	-90	-65	-40	-15	10	35	60	85
	S	115	140	165	190	215	240	265	290
Mass (kg)	W/o brake	2.4	2.6	2.8	2.9	3.1	3.3	3.4	3.6
	W/ brake	2.7	2.9	3.1	3.2	3.4	3.6	3.7	3.9

(Note) If the length for R is negative, the length of the actuator body is shorter than the motor unit.

### Applicable Controllers

The RCS4 series actuators can be operated by the controllers indicated below. Please select the type depending on your intended use.

Name	External view	Max. number of connectable axes	Input power	Control method				Maximum number of positioning points	Reference page	
				Positioner	Pulse train	Program	Network * Option			
SCON-CB/CGB		1	Single phase 115V/230VAC	●	●	-	DeviceNet CC-Link PROFINET CompoNet EtherCAT EtherNet/IP Note: The type of compatible networks will vary depending on the controller. Please refer to the reference page for more information.	512 (768 for network spec.)	Please see P.151	
SCON-LC/LCG (*)		1		-	-	●		512 (768 for network spec.)		
SCON-CAL/CGAL		1		●	-	-		512 (768 for network spec.)		
MSCON-C		6		This model is network-compatible only.				256		
SSEL-CS		2		●	-	●		20000		
XSEL-P/Q or XSEL-RA/SA (*)		6 or 8 (Depending on the type)	Single phase 230VAC Three-phase 230VAC	-	-	●	20000 or 55000 (Depending on the type)	Please see the dedicated controller catalog or manual.		

(\*) Coming soon

Foreword  
Slider Type  
Wide Slider Type  
Rod Type  
Radial Cylinder  
Wide Radial Cylinder  
Table Type  
Cleanroom Slider  
Cleanroom Wide Slider  
Options  
Reference Data  
Controller

# RCS4-TA6R□-DB <with Double-block Guide>

Battery-less Absolute
Motor Unit Coupled
Side-mounted Motor
Body Width 60\* mm
230v AC Servo Motor

Model Specification Items	<b>RCS4</b>	<b>TA6R</b>	<b>WA</b>	<b>100</b>	□	□	<b>T2</b>	□	<b>DB</b>	□
	Series	Type	Encoder Type	Motor Type	Lead	Stroke	Applicable Controllers	Cable Length	Options	
			WA: Battery-less Absolute	100: Servo motor 100W	12:12mm 6: 6mm 3: 3mm	45:45mm + 320:320mm	T2:SCON MSCON SSEL XSEL-P/Q XSEL-RA/SA	N : None P : 1m S : 3m M : 5m X□□ : Specified Length R□□ : Robot Cable	Refer to Options table below. * Please order alphabetically including "DB". (Make sure to specify either ML or MR)	* Body width does not include the width of the side-mounted motor.

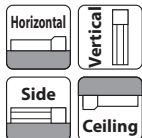

\* Depending on the model, there may be some limitations to using the vertical, side, and ceiling mount positions. Please refer to the Selection Notes on P.138 for more information.



- (1) Longer strokes may cause the maximum speed to decrease due to resonance of the ball screw. Be sure to check the maximum speed of the desired stroke in the Actuator Specifications table, which can be found below.
- (2) Both the horizontal and vertical payloads assume operation at an acceleration of 0.3G.
- (3) When the acceleration is increased, the payload will be reduced. Please refer to "Table of Payload by Acceleration" on P.139 for more details.
- (4) Estimated allowable duty varies depending on operating conditions (payload, acceleration/deceleration, etc.). Please refer to P. 149 for more information.
- (5) Please refer to the graphs shown on P.148 for the allowable load mass.

## Actuator Specifications

### Lead and Payload

Model Number	Motor wattage (W)	Lead (mm)	Max. payload		Rated thrust (N)	Stroke (mm)
			Horizontal (kg)	Vertical (kg)		
RCS4-TA6R-WA-100-12-①-T2-②-DB-③	100	12	14	6	142	45~120 (25mm increments)
RCS4-TA6R-WA-100-6-①-T2-②-DB-③		6	20	10	283	170~320 (50mm increments)
RCS4-TA6R-WA-100-3-①-T2-②-DB-③		3	20	12	566	

Legend: ① Stroke ② Cable Length ③ Option

### Stroke and Max Speed (Unit: mm/s)

Lead	Stroke	45~270 (mm)	320 (mm)
		12	720
6	360	285	
3	180	140	

## Cable Length

Type	Cable Code
Standard	P (1m)
	S (3m)
	M (5m)
Specified length (Standard cable)	X06 (6m) ~ X10 (10m)
	X11 (11m) ~ X15 (15m)
	X16 (16m) ~ X20 (20m)
	R01 (1m) ~ R03 (3m)
Robot cable	R04 (4m) ~ R05 (5m)
	R06 (6m) ~ R10 (10m)
	R11 (11m) ~ R15 (15m)
	R16 (16m) ~ R20 (20m)

## Actuator Specifications

Item	Description
Drive system	Ball screw ø10mm, rolled C10
Positioning repeatability	±0.01 mm
Lost motion	0.1mm or less
Base	Material: Aluminum with white alumite treatment
Allowable static moment	Ma direction 169N·m, Mb direction 242N·m, Mc direction 137N·m
Allowable dynamic moment (*1)	Ma direction 49.5N·m, Mb direction 70.7N·m, Mc direction 40N·m
Ambient operating temp. & humidity	0~40°C, 85% RH or less (Non-condensing)

(\*1) Assumes a standard rated life of 5000km. The service life will vary depending on operation and installation conditions. Please contact IAI for details of the running life.

Allowable load moment directions



If the load moments in Ma/Mb/Mc direction are within the allowable ranges, there is no overhang load length limit. Please refer to the RCS4 manual regarding the displacement of the table.

## Options

Name	Option Code	Reference Page
Brake	<b>B</b>	See P.131
Cable exit direction (Top)	<b>CJT</b>	See P.131
Cable exit direction (Bottom)	<b>CJB</b>	See P.131
Cable exit direction (Outside)	<b>CJO</b>	See P.131
Motor side-mounted to left (standard)	<b>ML</b>	See P.135
Motor side-mounted to right	<b>MR</b>	See P.135
Non-motor end specification	<b>NM</b>	See P.136

(\*1) EU option will be available soon.

Round cable joint connector with screw locking (*1)	<b>EU</b>	See P.131
---	-----------	-----------

## Dimensions

CAD drawings can be downloaded from our website.

www.robocylinder.de



\*1 When the table is returning to its home position, please be mindful of possible interference from surrounding objects, as it will travel until it reaches the M.E.  
M.E: Mechanical end S.E: Stroke end

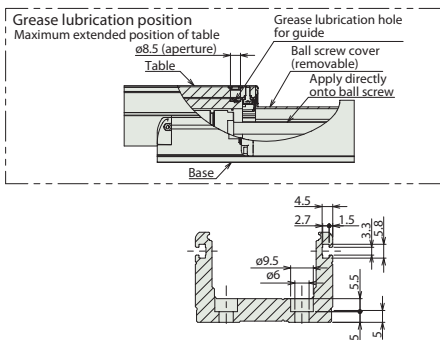

Details of T-slot and base mounting counterbored holes

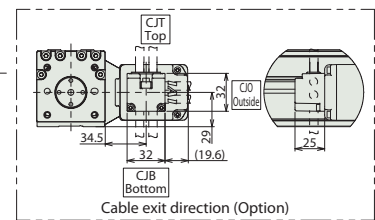
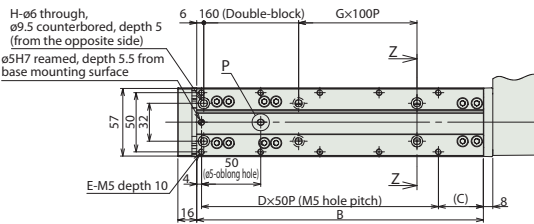
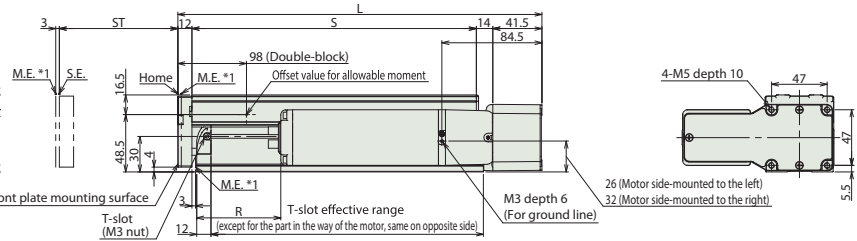
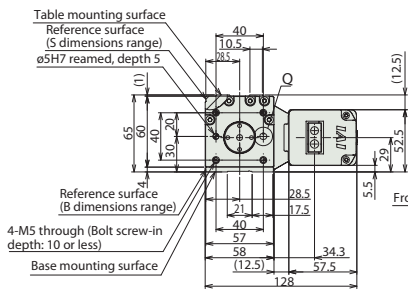
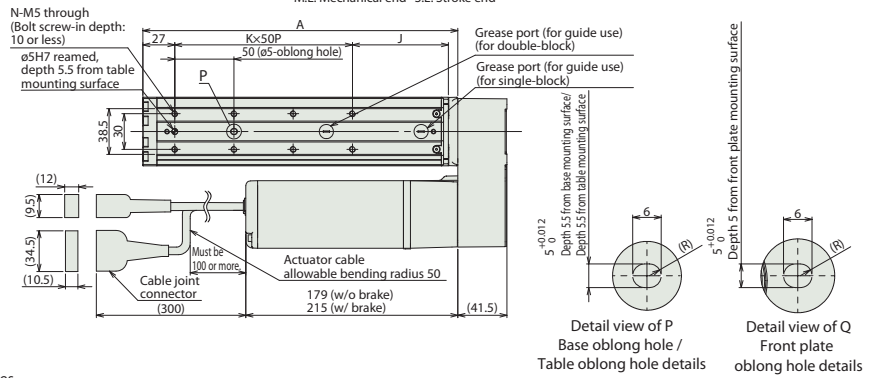

### Dimensions and Mass by Stroke

	ST	70	95	120	170	220	270	320	
L	282.5	307.5	332.5	357.5	407.5	457.5	507.5	557.5	
A	241	266	291	316	366	416	466	516	
B	217	242	267	292	342	392	442	492	
C	13	38	13	38	38	38	38	38	
D	4	4	5	5	6	7	8	9	
E	10	10	12	12	14	16	18	20	
G	0	0	0	0	1	1	2	2	
H	4	4	4	4	6	6	8	8	
J	56	81	56	81	81	81	81	81	
K	3	3	4	4	5	6	7	8	
N	8	8	10	10	12	14	16	18	
R (Note)	W/o brake	46	71	96	121	171	221	271	321
	W/ brake	10	35	60	85	135	185	235	285
	S	215	240	265	290	340	390	440	490
Mass (kg)	W/o brake	3.3	3.4	3.6	3.8	4.1	4.4	4.8	5.1
	W/ brake	3.6	3.7	3.9	4.1	4.4	4.7	5.1	5.4

(Note) If the length for R is negative, the length of the actuator body is shorter than the motor unit.

### Applicable Controllers

The RCS4 series actuators can be operated by the controllers indicated below. Please select the type depending on your intended use.

Name	External view	Max. number of connectable axes	Input power	Control method				Maximum number of positioning points	Reference page	
				Positioner	Pulse train	Program	Network * Option			
SCON-CB/CGB		1	Single phase 115V/230VAC	●	●	-	DeviceNet CC-Link PROFINET CompoNet EtherCAT EtherNet/IP	512 (768 for network spec.)	Please see P.151	
SCON-LC/LCG (*)		1		-	-	●		512 (768 for network spec.)		
SCON-CAL/CGAL		1		-	-	-		512 (768 for network spec.)		
MSCON-C		6		This model is network-compatible only.				256		
SSEL-CS		2		●	-	●		20000		
XSEL-P/Q or XSEL-RA/SA (*)		6 or 8 (Depending on the type)	Single phase 230VAC Three-phase 230VAC	-	-	●	20000 or 55000 (Depending on the type)	Please see the dedicated controller catalog or manual.		

(\*) Coming soon

Foreword  
Slider Type  
Wide Slider Type  
Rod Type  
Radial Cylinder  
Wide Radial Cylinder  
Table Type  
Cleanroom Slider  
Cleanroom Wide Slider  
Options  
Reference Data  
Controller

# RCS4-TA7R <with Single-block Guide>

Battery-less Absolute
Motor Unit Coupled
Side-mounted Motor
Body Width 70\* mm
230v AC Servo Motor

Model Specification Items	<b>RCS4</b> — <b>TA7R</b> — <b>WA</b> — <b>200</b> — [ ] — [ ] — [ ]	<b>T2</b> — [ ] — [ ]	* Body width does not include the width of the side-mounted motor.				
	Series — Type — Encoder Type — Motor Type — Lead — Stroke — Applicable Controllers — Cable Length — Options	T2:SCON MSCON SSEL XSEL-P/Q XSEL-RA/SA		N : None P : 1m S : 3m M : 5m X□□ : Specified Length R□□ : Robot Cable			
	WA: Battery-less Absolute	200: Servo motor 200W	24:24mm 16:16mm 8: 8mm 4: 4mm	25:25mm 300:300mm			Refer to Options table below.

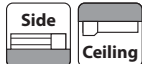

\* Depending on the model, there may be some limitations to using the vertical, side, and ceiling mount positions. Please refer to the Selection Notes on P.138 for more information.



**POINT Selection Notes**

- Both the horizontal and vertical payloads assume operation at an acceleration of 0.3G.
- When the acceleration is increased, the payload will be reduced. Please refer to "Table of Payload by Acceleration" on P.139 for more details.
- Estimated allowable duty varies depending on operating conditions (payload, acceleration/deceleration, etc.). Please refer to P. 149 for more information.
- Please refer to the graphs shown on P.148 for the allowable load mass.

## Actuator Specifications

### Lead and Payload

Model Number	Motor wattage (W)	Lead (mm)	Max. payload		Rated thrust (N)	Stroke (mm)
			Horizontal (kg)	Vertical (kg)		
RCS4-TA7R-WA-200-24-①-T2-②-③	200	24	12	5	142	25~200 (25mm increments) 250~300 (50mm increments)
RCS4-TA7R-WA-200-16-①-T2-②-③		16	15	10	214	
RCS4-TA7R-WA-200-8-①-T2-②-③		8	15	18	427	
RCS4-TA7R-WA-200-4-①-T2-②-③		4	15	20	855	

Legend: ① Stroke ② Cable Length ③ Option

### Stroke and Max Speed (Unit: mm/s)

Lead	Stroke	
	25~300 (mm)	25~300 (mm)
24	1200	
16	960	
8	480	
4	240	

## Cable Length

Type	Cable Code
Standard	P (1m)
	S (3m)
	M (5m)
Specified length (Standard cable)	X06 (6m) ~ X10 (10m)
	X11 (11m) ~ X15 (15m)
	X16 (16m) ~ X20 (20m)
	R01 (1m) ~ R03 (3m)
Robot cable	R04 (4m) ~ R05 (5m)
	R06 (6m) ~ R10 (10m)
	R11 (11m) ~ R15 (15m)
	R16 (16m) ~ R20 (20m)

## Actuator Specifications

Item	Description
Drive system	Ball screw ø12mm, rolled C10
Positioning repeatability	±0.01mm
Lost motion	0.1mm or less
Base	Material: Aluminum with white alumite treatment
Allowable static moment	Ma direction 115N·m, Mb direction 115N·m, Mc direction 229N·m
Allowable dynamic moment (*1)	Ma direction 44.7N·m, Mb direction 44.7N·m, Mc direction 89.1N·m
Ambient operating temp. & humidity	0~40°C, 85% RH or less (Non-condensing)

(\*1) Assumes a standard rated life of 5000km. The service life will vary depending on operation and installation conditions. Please contact IAI for details of the running life.

Allowable load moment directions

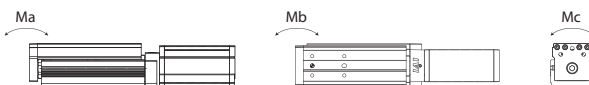

If the load moments in Ma/Mb/Mc direction are within the allowable ranges, there is no overhang load length limit. Please refer to the RCS4 manual regarding the displacement of the table.

Round cable joint connector with screw locking (*1)	<b>EU</b>	See P.131
---	-----------	-----------

## Options

Name	Option Code	Reference Page
Brake	<b>B</b>	See P.131
Cable exit direction (Top)	<b>CJT</b>	See P.131
Cable exit direction (Bottom)	<b>CJB</b>	See P.131
Cable exit direction (Outside)	<b>CJO</b>	See P.131
Motor side-mounted to left (standard)	<b>ML</b>	See P.135
Motor side-mounted to right	<b>MR</b>	See P.135
Non-motor end specification	<b>NM</b>	See P.136

(\*1) EU option will be available soon.



## Dimensions

CAD drawings can be downloaded from our website.  
www.robocylinder.de



\*1 When the table is returning to its home position, please be mindful of possible interference from surrounding objects, as it will travel until it reaches the M.E.  
M.E: Mechanical end S.E: Stroke end

### Grease lubrication position

Maximum extended position of table

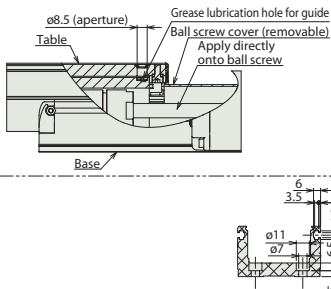

Cross section of Z-Z  
Details of T-slot and base mounting counterbored holes

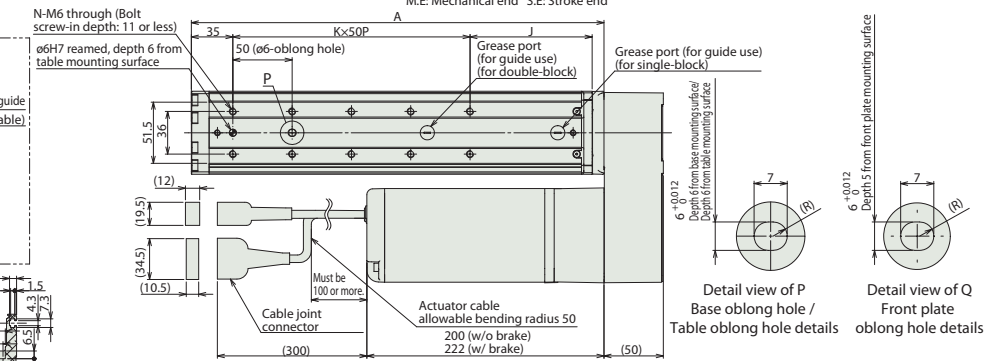
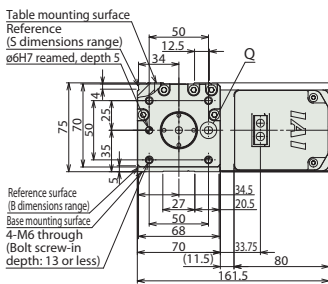

Detail view of P  
Base oblong hole /  
Table oblong hole details

Detail view of Q  
Front plate  
oblong hole details

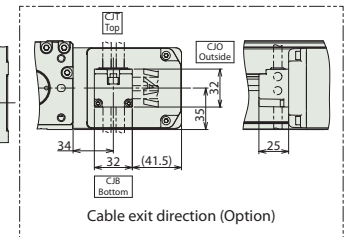
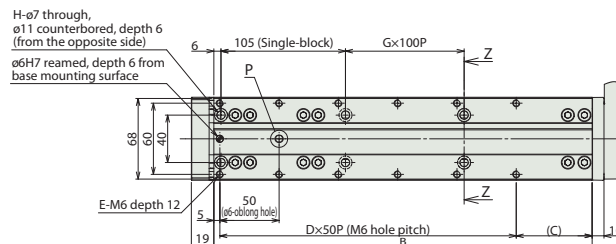
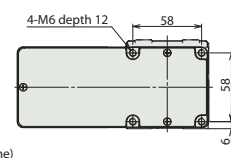
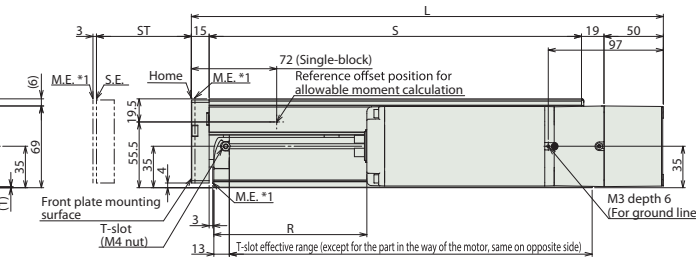

### Dimensions and Mass by Stroke

		25	50	75	100	125	150	175	200	250	300
ST		25	50	75	100	125	150	175	200	250	300
L		223	248	273	298	323	348	373	398	448	498
A		173	198	223	248	273	298	323	348	398	448
B		144	169	194	219	244	269	294	319	369	419
C		39	64	39	64	39	64	39	64	64	64
D		2	2	3	3	4	4	5	5	6	7
E		6	6	8	8	10	10	12	12	14	16
G		0	0	0	0	1	1	1	1	2	2
H		4	4	4	4	6	6	6	6	8	8
J		78	103	78	103	78	103	78	103	103	103
K		1	1	2	2	3	3	4	4	5	6
N		4	4	6	6	8	8	10	10	12	14
R (Note)	W/o brake	-46	-21	4	29	54	79	104	129	179	229
	W/ brake	-68	-43	-18	7	32	57	82	107	157	207
	S	139	164	189	214	239	264	289	314	364	414
Mass (kg)	W/o brake	4.6	4.8	5.0	5.2	5.5	5.7	5.9	6.1	6.6	7.0
	W/ brake	5.1	5.3	5.5	5.7	6	6.2	6.4	6.6	7.1	7.5

(Note) If the length for R is negative, the length of the actuator body is shorter than the motor unit.

### Applicable Controllers

The RCS4 series actuators can be operated by the controllers indicated below. Please select the type depending on your intended use.

Name	External view	Max. number of connectable axes	Input power	Control method				Maximum number of positioning points	Reference page	
				Positioner	Pulse train	Program	Network * Option			
SCON-CB/CGB		1	Single phase 115V/230VAC	●	●	—	DeviceNet CC-Link PROFINET CompoNet EtherCAT EtherNet/IP	512 (768 for network spec.)	Please see P.151	
SCON-LC/LCG (*)		1		—	—	●		512 (768 for network spec.)		
SCON-CAL/CGAL		1		●	—	—		512 (768 for network spec.)		
MSCON-C		6		This model is network-compatible only.				256		
SSEL-CS		2		●	—	●		20000		
XSEL-P/Q or XSEL-RA/SA (*)		6 or 8 (Depending on the type)	Single phase 230VAC Three-phase 230VAC	—	—	●	20000 or 55000 (Depending on the type)	Please see the dedicated controller catalog or manual.		
Note: The type of compatible networks will vary depending on the controller. Please refer to the reference page for more information.										

(\*) Coming soon

Foreword  
Slider Type  
Wide Slider Type  
Rod Type  
Radial Cylinder  
Wide Radial Cylinder  
Table Type  
Cleanroom Slider  
Cleanroom Wide Slider  
Options  
Reference Data  
Controller

# RCS4-TA7R□-DB <with Double-block Guide>

Battery-less Absolute
Motor Unit Coupled
Side-mounted Motor
Body Width 70\* mm
230v AC Servo Motor

Model Specification Items	<b>RCS4</b>	<b>TA7R</b>	<b>WA</b>	<b>200</b>	□	□	<b>T2</b>	□	<b>DB</b>	□	* Body width does not include the width of the side-mounted motor.
	Series	Type	Encoder Type	Motor Type	Lead	Stroke	Applicable Controllers	Cable Length	Options		
			WA: Battery-less Absolute	200: Servo motor 200W	16: 16mm 8: 8mm 4: 4mm	40: 40mm 390: 390mm	T2: SCON MSCON SSEL XSEL-P/Q XSEL-RA/SA	N: None P: 1m S: 3m M: 5m X□□: Specified Length R□□: Robot Cable	Refer to Options table below. * Please order alphabetically including "DB". (Make sure to specify either ML or MR)		

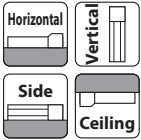

\* Depending on the model, there may be some limitations to using the vertical, side, and ceiling mount positions. Please refer to the Selection Notes on P.138 for more information.



**POINT Selection Notes**

- (1) Longer strokes may cause the maximum speed to decrease due to resonance of the ball screw. Be sure to check the maximum speed of the desired stroke in the Actuator Specifications table, which can be found below.
- (2) Both the horizontal and vertical payloads assume operation at an acceleration of 0.3G.
- (3) When the acceleration is increased, the payload will be reduced. Please refer to "Table of Payload by Acceleration" on P.139 for more details.
- (4) Estimated allowable duty varies depending on operating conditions (payload, acceleration/deceleration, etc.). Please refer to P. 149 for more information.
- (5) Please refer to the graphs shown on P.148 for the allowable load mass.

## Actuator Specifications

### Lead and Payload

Model Number	Motor wattage (W)	Lead (mm)	Max. payload		Rated thrust (N)	Stroke (mm)
			Horizontal (kg)	Vertical (kg)		
RCS4-TA7R-WA-200-16-①-T2-②-DB-③	200	16	25	8	214	40~90 (25mm increments) 140~390 (50mm increments)
RCS4-TA7R-WA-200-8-①-T2-②-DB-③		8	30	18	427	
RCS4-TA7R-WA-200-4-①-T2-②-DB-③		4	30	24	855	

Legend: ① Stroke ② Cable Length ③ Option

### Stroke and Max Speed (Unit: mm/s)

Lead	Stroke	40~290 (mm)	340 (mm)	390 (mm)
		16	960	730
8		480	365	300
4		240	180	150

## Cable Length

Type	Cable Code
Standard	P (1m)
	S (3m)
	M (5m)
Specified length (Standard cable)	X06 (6m) ~ X10 (10m)
	X11 (11m) ~ X15 (15m)
	X16 (16m) ~ X20 (20m)
	R01 (1m) ~ R03 (3m)
Robot cable	R04 (4m) ~ R05 (5m)
	R06 (6m) ~ R10 (10m)
	R11 (11m) ~ R15 (15m)
	R16 (16m) ~ R20 (20m)

## Actuator Specifications

Item	Description
Drive system	Ball screw ø12mm, rolled C10
Positioning repeatability	±0.01mm
Lost motion	0.1mm or less
Base	Material: Aluminum with white alumite treatment
Allowable static moment	Ma direction 620N·m, Mb direction 620N·m, Mc direction 458N·m
Allowable dynamic moment (*1)	Ma direction 196N·m, Mb direction 196N·m, Mc direction 145N·m
Ambient operating temp. & humidity	0~40°C, 85% RH or less (Non-condensing)

(\*1) Assumes a standard rated life of 5000km. The service life will vary depending on operation and installation conditions. Please contact IAI for details of the running life.

Allowable load moment directions

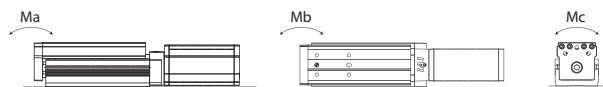

If the load moments in Ma/Mb/Mc direction are within the allowable ranges, there is no overhang load length limit. Please refer to the RCS4 manual regarding the displacement of the table.

## Options

Name	Option Code	Reference Page
Brake	<b>B</b>	See P.131
Cable exit direction (Top)	<b>CJT</b>	See P.131
Cable exit direction (Bottom)	<b>CJB</b>	See P.131
Cable exit direction (Outside)	<b>CJO</b>	See P.131
Motor side-mounted to left (standard)	<b>ML</b>	See P.135
Motor side-mounted to right	<b>MR</b>	See P.135
Non-motor end specification	<b>NM</b>	See P.136

(\*1) EU option will be available soon.

Round cable joint connector with screw locking (*1)	<b>EU</b>	See P.131
---	-----------	-----------

## Dimensions

CAD drawings can be downloaded from our website.  
www.robocylinder.de



\*1 When the table is returning to its home position, please be mindful of possible interference from surrounding objects, as it will travel until it reaches the M.E.  
M.E: Mechanical end S.E: Stroke end

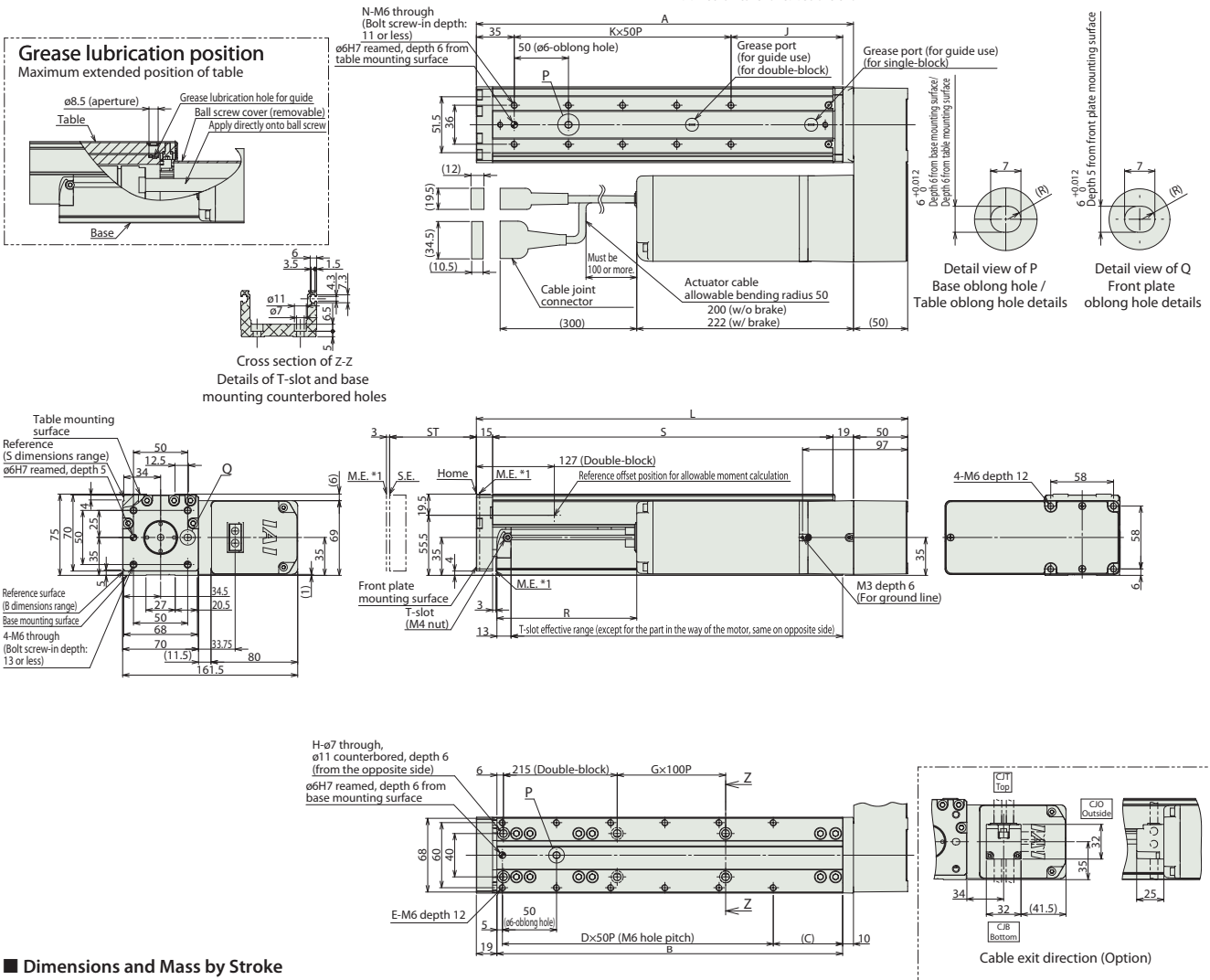

### Dimensions and Mass by Stroke

ST	40	65	90	140	190	240	290	340	390	
L	348	373	398	448	498	548	598	648	698	
A	298	323	348	398	448	498	548	598	648	
B	269	294	319	369	419	469	519	569	619	
C	64	39	64	64	64	64	64	64	64	
D	4	5	5	6	7	8	9	10	11	
E	10	12	12	14	16	18	20	22	24	
G	0	0	0	1	1	2	2	3	3	
H	4	4	4	6	6	8	8	10	10	
J	103	78	103	103	103	103	103	103	103	
K	3	4	4	5	6	7	8	9	10	
N	8	10	10	12	14	16	18	20	22	
R	W/o brake	79	104	129	179	229	279	329	379	429
	W/ brake	57	82	107	157	207	257	307	357	407
	S	264	289	314	364	414	464	514	564	614
Mass (kg)	W/o brake	6.1	6.3	6.5	7.0	7.4	7.9	8.3	8.8	9.2
	W/ brake	6.6	6.8	7	7.5	7.9	8.4	8.8	9.3	9.7

### Applicable Controllers

The RCS4 series actuators can be operated by the controllers indicated below. Please select the type depending on your intended use.

Name	External view	Max. number of connectable axes	Input power	Control method				Maximum number of positioning points	Reference page
				Positioner	Pulse train	Program	Network * Option		
SCON-CB/CGB		1	Single phase 115V/230VAC	●	●	—	DeviceNet CCLink PROFINET CompoNet EtherCAT EtherNet/IP	512 (768 for network spec.)	Please see P.151
SCON-LC/LCG (*)		1		—	—	●		512 (768 for network spec.)	
SCON-CAL/CGAL		1		●	—	—		512 (768 for network spec.)	
MSCON-C		6		This model is network-compatible only.				256	
SSEL-CS		2		●	—	●	20000		
XSEL-P/Q or XSEL-RA/SA (*)		6 or 8 (Depending on the type)		Single phase 230VAC Three-phase 230VAC	—	—	●	20000 or 55000 (Depending on the type)	

Note: The type of compatible networks will vary depending on the controller. Please refer to the reference page for more information.

(\*) Coming soon

Foreword  
Slider Type  
Wide Slider Type  
Rod Type  
Radial Cylinder  
Wide Radial Cylinder  
Table Type  
Cleanroom Slider  
Cleanroom Wide Slider  
Options  
Reference Data  
Controller





# RCS4CR-SA6C

$\pm 10\mu\text{m}$ Standard	$\pm 5\mu\text{m}$ Optional	Clean-room Spec.	Battery-less Absolute	Motor Unit Coupled	Straight Motor	Body Width <b>60 mm</b>	<b>230v</b> AC Servo Motor
---------------------------------	--------------------------------	------------------	-----------------------	--------------------	----------------	----------------------------	-------------------------------

Model Specification Items	<b>RCS4CR</b> — <b>SA6C</b> — <b>WA</b> — <b>100</b> — [ ] — [ ] — [ ] — <b>T2</b> — [ ] — [ ]
	Series — Type — Encoder Type — Motor Type — Lead — Stroke — Applicable Controllers — Cable Length — Options
	WA: Battery-less Absolute 100: Servo motor 100W 20:20mm 12:12mm 6: 6mm 3: 3mm 50:50mm 800:800mm (50mm increments) T2:SCON MSCON SSEL XSEL-P/Q XSEL-RA/SA N : None P : 1m S : 3m M : 5m X□□ : Specified Length R□□ : Robot Cable Refer to Options table below.

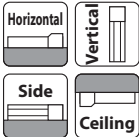

\* Depending on the model, there may be some limitations to using the vertical, side, and ceiling mount positions. Please refer to the Selection Notes on P.138 for more information.



- (1) Longer strokes may cause the maximum speed to decrease due to resonance of the ball screw. Be sure to check the maximum speed of the desired stroke in the Actuator Specifications table, which can be found below.
- (2) Both the horizontal and vertical payloads assume operation at an acceleration of 0.3G.
- (3) When the acceleration is increased, the payload will be reduced. Please refer to "Table of Payload by Acceleration" on P.139 for more details.
- (4) Estimated allowable duty varies depending on operating conditions (payload, acceleration/deceleration, etc.). Please refer to P. 149 for more information.

## Actuator Specifications

### Lead and Payload

Model Number	Motor wattage (W)	Lead (mm)	Max. payload		Rated thrust (N)	Stroke (mm)
			Horizontal (kg)	Vertical (kg)		
RCS4CR-SA6C-WA-100-20-①-T2-②-③	100	20	18	6	85	50~800 (50mm increments)
RCS4CR-SA6C-WA-100-12-①-T2-②-③		12	30	11	142	
RCS4CR-SA6C-WA-100-6-①-T2-②-③		6	45	15	283	
RCS4CR-SA6C-WA-100-3-①-T2-②-③		3	45	15	566	

Legend: ① Stroke ② Cable Length ③ Option

### Stroke and Max Speed/Suction Amount

(Unit: mm/s)

Stroke (mm)	50~500	550	600	650	700	750	800	Suction amount (NE/min)
	(50mm increments)	(mm)	(mm)	(mm)	(mm)	(mm)	(mm)	
20	1200	1130	970	840	735	650	575	100
12	720	620	535	460	405	355	315	70
6	360	305	265	230	200	175	155	30
3	180	150	130	115	100	85	75	15

## Cable Length

Type	Cable Code
Standard	<b>P</b> (1m)
	<b>S</b> (3m)
	<b>M</b> (5m)
Specified length (Standard cable)	<b>X06</b> (6m) ~ <b>X10</b> (10m)
	<b>X11</b> (11m) ~ <b>X15</b> (15m)
	<b>X16</b> (16m) ~ <b>X20</b> (20m)
	<b>R01</b> (1m) ~ <b>R03</b> (3m)
Robot cable	<b>R04</b> (4m) ~ <b>R05</b> (5m)
	<b>R06</b> (6m) ~ <b>R10</b> (10m)
	<b>R11</b> (11m) ~ <b>R15</b> (15m)
	<b>R16</b> (16m) ~ <b>R20</b> (20m)

## Actuator Specifications

Item	Description
Drive system	Ball screw $\phi 10\text{mm}$ , rolled C10
Positioning repeatability (*1)	$\pm 0.01\text{mm}$ [ $\pm 0.005\text{mm}$ ]
Lost motion	0.1mm or less
Base	Material: Aluminum with white alumite treatment
Allowable static moment	Ma direction: 48.5N·m, Mb direction: 69.3N·m, Mc direction: 103N·m
Allowable dynamic moment (*2)	Ma direction: 11.6N·m, Mb direction: 16.6N·m, Mc direction: 24.6N·m
Cleanliness	ISO class 2.5 or equiv. (ISO STD 14644-1:2015), US class 10 (FED STD 209D)
Ambient operating temp. & humidity	0~40°C, 85% RH or less (Non-condensing)

(\*1) Values in [ ] are for high-precision specification.  
(\*2) Assumes a standard rated life of 5000km. The service life will vary depending on operation and installation conditions. Please contact IAI for details of the running life.

• Reference for overhang load length: Ma: 220mm or less, Mb, Mc: 220mm or less  
Allowable load moment directions

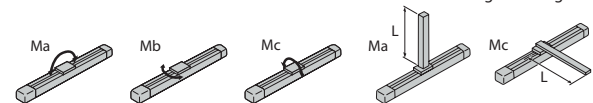

If the load moments in Ma/Mb/Mc direction are within the allowable ranges, there is no overhang load length limit.

Round cable joint connector with screw locking (*3)	<b>EU</b>	See P.131
---	-----------	-----------

## Options

Name	Option Code	Reference Page
Brake	<b>B</b>	See P.131
Cable exit direction (Top)	<b>CJT</b>	See P.131
Cable exit direction (Right)	<b>CJR</b>	See P.131
Cable exit direction (Left)	<b>CJL</b>	See P.131
Cable exit direction (Bottom)	<b>CJB</b>	See P.131
High-Precision specification (*1)	<b>HPR</b>	See P.134
Non-motor end specification	<b>NM</b>	See P.136
Air suction joint in opposite position	<b>VR</b>	See P.137
Double slider (*2)	<b>W</b>	See P.137

(\*1) Double slider cannot be selected. (\*2) Some leads cannot be selected. (Please see P. 150) (\*3) EU option will be available soon.

## Dimensions

CAD drawings can be downloaded from our website.  
[www.robocylinder.de](http://www.robocylinder.de)



\*1 When the slider is returning to its home position, please be careful of interference from surrounding objects, as it will travel until it reaches the M.E.  
 M.E: Mechanical end S.E: Stroke end

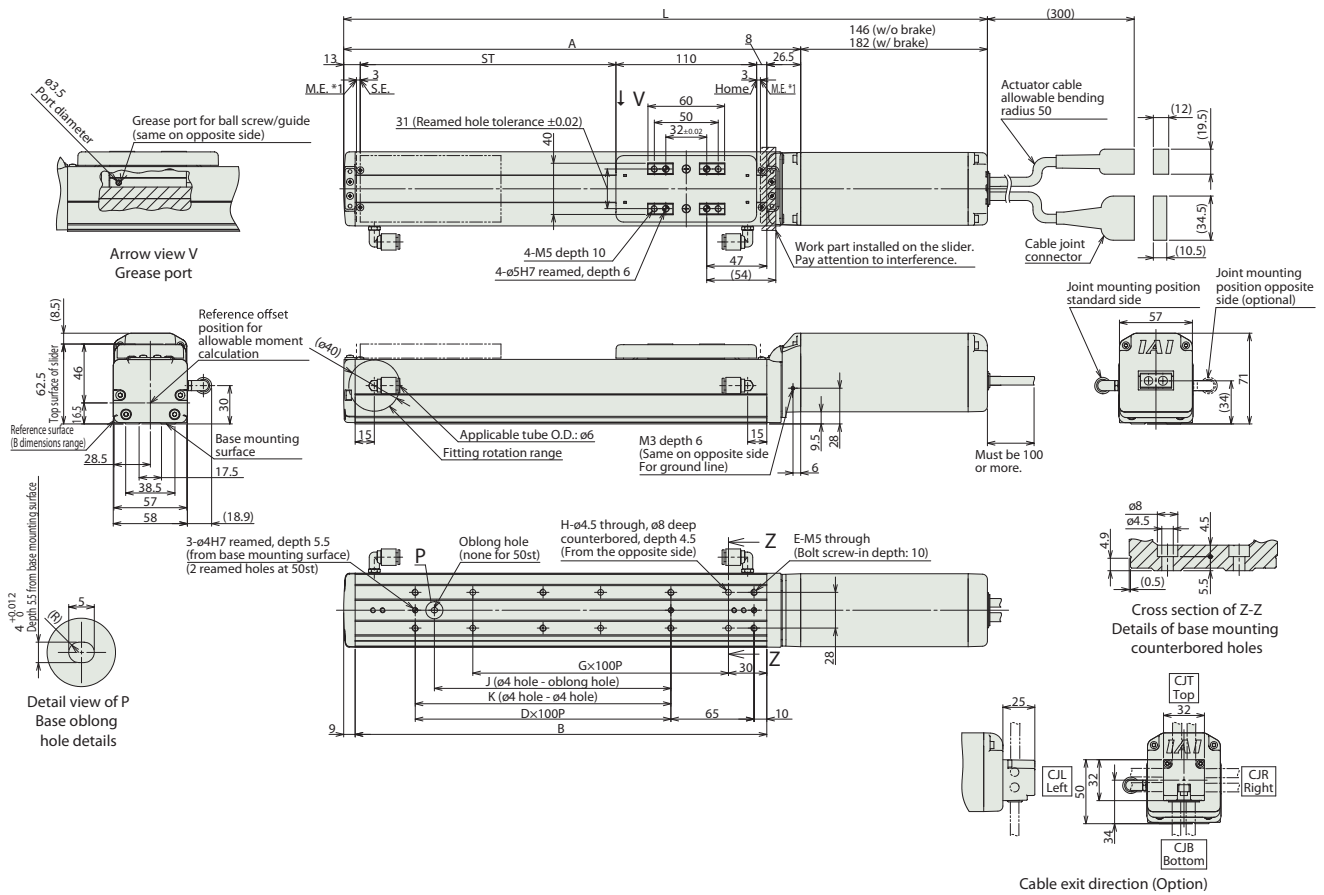

## Dimensions and Mass by Stroke

L	Stroke	50	100	150	200	250	300	350	400	450	500	550	600	650	700	750	800
	W/o brake	353.5	403.5	453.5	503.5	553.5	603.5	653.5	703.5	753.5	803.5	853.5	903.5	953.5	1003.5	1053.5	1103.5
W/ brake	389.5	439.5	489.5	539.5	589.5	639.5	689.5	739.5	789.5	839.5	889.5	939.5	989.5	1039.5	1089.5	1139.5	
A	207.5	257.5	307.5	357.5	407.5	457.5	507.5	557.5	607.5	657.5	707.5	757.5	807.5	857.5	907.5	957.5	
B	172	222	272	322	372	422	472	522	572	622	672	722	772	822	872	922	
D	0	1	1	2	2	3	3	4	4	5	5	6	6	7	7	8	
E	4	6	6	8	8	10	10	12	12	14	14	16	16	18	18	20	
G	1	1	2	2	3	3	4	4	5	5	6	6	7	7	8	8	
H	4	4	6	6	8	8	10	10	12	12	14	14	16	16	18	18	
J	0	85	85	185	185	285	285	385	385	485	485	585	585	685	685	785	
K	0	100	100	200	200	300	300	400	400	500	500	600	600	700	700	800	
Mass (kg)	W/o brake	2.0	2.2	2.4	2.6	2.7	2.9	3.1	3.3	3.4	3.6	3.8	4.0	4.2	4.3	4.5	4.7
	W/ brake	2.3	2.5	2.7	2.9	3	3.2	3.4	3.6	3.7	3.9	4.1	4.3	4.5	4.6	4.8	5

## Applicable Controllers

The RCS4 series actuators can be operated by the controllers indicated below. Please select the type depending on your intended use.

Name	External view	Max. number of connectable axes	Input power	Control method				Maximum number of positioning points	Reference page	
				Positioner	Pulse train	Program	Network + Option			
SCON-CB/CGB		1	Single phase 115V/230VAC	●	●	-	DeviceNet CC-Link CANopen CompoNet EtherCAT EtherNet/IP Note: The type of compatible networks will vary depending on the controller. Please refer to the reference page for more information.	512 (768 for network spec.)	Please see the dedicated controller catalog or manual.	
SCON-LC/LCG (*)		1		-	-	●		512 (768 for network spec.)		
SCON-CAL/CGAL		1		●	-	-		512 (768 for network spec.)		
MSCON-C		6		This model is network-compatible only.				256		
SSEL-CS		2		●	-	●		20000		
XSEL-P/Q or XSEL-RA/SA (*)		6 or 8 (Depending on the type)	Single phase 230VAC Three-phase 230VAC	-	-	●	20000 or 55000 (Depending on the type)			

(\*) Coming soon

Foreword  
 Slider Type  
 Wide Slider Type  
 Rod Type  
 Radial Cylinder  
 Wide Radial Cylinder  
 Table Type  
 Cleanroom Slider  
 Cleanroom Wide Slider  
 Options  
 Reference Data  
 Controller

# RCS4CR-SA7C

$\pm 10\mu\text{m}$ Standard	$\pm 5\mu\text{m}$ Optional	Clean-room Spec.	Battery-less Absolute	Motor Unit Coupled	Straight Motor	Body Width <b>70 mm</b>	<b>230v</b> AC Servo Motor
---------------------------------	--------------------------------	------------------	-----------------------	--------------------	----------------	----------------------------	-------------------------------

Model Specification Items	<b>RCS4CR</b> — <b>SA7C</b> — <b>WA</b> — <b>200</b> — [ ] — [ ] — [ ] — [ ] — [ ]
	Series — Type — Encoder Type — Motor Type — Lead — Stroke — Applicable Controllers — Cable Length — Options
	WA: Battery-less Absolute      200: Servo motor 200W      24:24mm 16:16mm 8: 8mm 4: 4mm      50:50mm 800:800mm (50mm increments)      T2:SCON MSCON SSEL XSEL-P/Q XSEL-RA/SA      N : None P : 1m S : 3m M : 5m X [ ] : Specified Length R [ ] : Robot Cable      Refer to Options table below.

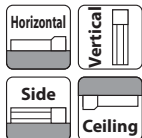

\* Depending on the model, there may be some limitations to using the vertical, side, and ceiling mount positions. Please refer to the Selection Notes on P.138 for more information.



- (1) Longer strokes may cause the maximum speed to decrease due to resonance of the ball screw. Be sure to check the maximum speed of the desired stroke in the Actuator Specifications table, which can be found below.
- (2) Both the horizontal and vertical payloads assume operation at an acceleration of 0.3G.
- (3) When the acceleration is increased, the payload will be reduced. Please refer to "Table of Payload by Acceleration" on P.139 for more details.
- (4) Estimated allowable duty varies depending on operating conditions (payload, acceleration/deceleration, etc.). Please refer to P. 149 for more information.

## Actuator Specifications

### Lead and Payload

Model Number	Motor wattage (W)	Lead (mm)	Max. payload		Rated thrust (N)	Stroke (mm)
			Horizontal (kg)	Vertical (kg)		
RCS4CR-SA7C-WA-200-24-[1]-T2-[2]-[3]	200	24	30	7	142	50~800 (50mm increments)
RCS4CR-SA7C-WA-200-16-[1]-T2-[2]-[3]		16	40	12	214	
RCS4CR-SA7C-WA-200-8-[1]-T2-[2]-[3]		8	45	20	427	
RCS4CR-SA7C-WA-200-4-[1]-T2-[2]-[3]		4	50	25	855	

Legend: [1] Stroke [2] Cable Length [3] Option

### Stroke and Max Speed/Suction Amount

(Unit: mm/s)

Stroke (mm)	50~500 (50mm increments)	550 (mm)	600 (mm)	650 (mm)	700 (mm)	750 (mm)	800 (mm)	Suction amount (N <sub>E</sub> /mm)
	Lead	1500	1440	1240	1095	965	850	
24	1500	1440	1240	1095	965	850	760	90
16	1000	965	830	720	635	560	500	70
8	500	475	410	355	315	275	245	40
4	240	235	205	175	155	135	120	30

## Cable Length

Type	Cable Code
Standard	<b>P</b> (1m)
	<b>S</b> (3m)
	<b>M</b> (5m)
Specified length (Standard cable)	<b>X06</b> (6m) ~ <b>X10</b> (10m)
	<b>X11</b> (11m) ~ <b>X15</b> (15m)
	<b>X16</b> (16m) ~ <b>X20</b> (20m)
	<b>R01</b> (1m) ~ <b>R03</b> (3m)
Robot cable	<b>R04</b> (4m) ~ <b>R05</b> (5m)
	<b>R06</b> (6m) ~ <b>R10</b> (10m)
	<b>R11</b> (11m) ~ <b>R15</b> (15m)
	<b>R16</b> (16m) ~ <b>R20</b> (20m)

## Actuator Specifications

Item	Description
Drive system	Ball screw $\phi 12\text{mm}$ , rolled C10
Positioning repeatability (*1)	$\pm 0.01\text{mm}$ [ $\pm 0.005\text{mm}$ ]
Lost motion	0.1mm or less
Base	Material: Aluminum with white alumite treatment
Allowable static moment	Ma direction 115N·m, Mb direction 115N·m, Mc direction 229N·m
Allowable dynamic moment (*2)	Ma direction 44.7N·m, Mb direction 44.7N·m, Mc direction 89.1N·m
Cleanliness	ISO class 2.5 or equiv. (ISO STD 14644-1:2015), US class 10 (FED STD 209D)
Ambient operating temp. & humidity	0~40°C, 85% RH or less (Non-condensing)

(\*1) Values in [ ] are for high-precision (for lead 4/8/16) specification.  
 (\*2) Assumes a standard rated life of 5000km. The service life will vary depending on operation and installation conditions. Please contact IAI for details of the running life.

• Reference for overhang load length: Ma: 300mm or less, Mb, Mc: 300mm or less  
 Allowable load moment directions      Overhang load lengths

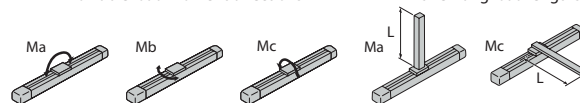

If the load moments in Ma/Mb/Mc direction are within the allowable ranges, there is no overhang load length limit.

Round cable joint connector with screw locking (*3)	<b>EU</b>	See P.131
---	-----------	-----------

## Options

Name	Option Code	Reference Page
Brake	<b>B</b>	See P.131
Cable exit direction (Top)	<b>CJT</b>	See P.131
Cable exit direction (Right)	<b>CJR</b>	See P.131
Cable exit direction (Left)	<b>CJL</b>	See P.131
Cable exit direction (Bottom)	<b>CJB</b>	See P.131
High-Precision specification (*1)	<b>HPR</b>	See P.134
Non-motor end specification	<b>NM</b>	See P.136
Air suction joint in opposite position	<b>VR</b>	See P.137
Double slider (*2)	<b>W</b>	See P.137

(\*1) When the lead is 24, it cannot be selected. Double slider cannot be selected. (\*2) Some leads cannot be selected. (Please see P. 150)

(\*3) EU option will be available soon.





# RCS4CR-SA8C

$\pm 10\mu\text{m}$ Standard	$\pm 5\mu\text{m}$ Optional	Clean-room Spec.	Battery-less Absolute	Motor Unit Coupled	Straight Motor	Body Width <b>90mm</b>	<b>230v</b> AC Servo Motor
---------------------------------	--------------------------------	------------------	-----------------------	--------------------	----------------	---------------------------	-------------------------------

Model Specification Items	<b>RCS4CR</b> — <b>SA8C</b> — <b>WA</b> — <b>400</b> — [ ] — [ ] — [ ] — <b>T2</b> — [ ] — [ ]
	Series — Type — Encoder Type — Motor Type — Lead — Stroke — Applicable Controllers — Cable Length — Options
	WA: Battery-less Absolute      400: Servo motor 400W      20:20mm 10:10mm 5: 5mm      50:50mm 1100:1100mm (50mm increments)      T2:SCON SSEL XSEL-P/Q XSEL-RA/SA      N: None P: 1m S: 3m M: 5m      Refer to Options table below.      X [ ] : Specified Length R [ ] : Robot Cable

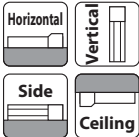

\* Depending on the model, there may be some limitations to using the vertical, side, and ceiling mount positions. Please refer to the Selection Notes on P.138 for more information.



**POINT Selection Notes**

- (1) Longer strokes may cause the maximum speed to decrease due to resonance of the ball screw. Be sure to check the maximum speed of the desired stroke in the Actuator Specifications table, which can be found below.
- (2) Both the horizontal and vertical payloads assume operation at an acceleration of 0.3G.
- (3) When the acceleration is increased, the payload will be reduced. Please refer to "Table of Payload by Acceleration" on P.139 for more details.
- (4) Estimated allowable duty varies depending on operating conditions (payload, acceleration/deceleration, etc.). Please refer to P. 149 for more information.

## Actuator Specifications

### Lead and Payload

Model Number	Motor wattage (W)	Lead (mm)	Max. payload (kg)	Rated thrust (N)	Stroke (mm)
RCS4CR-SA8C-WA-400-20-①-T2-②-③	400	20	60	339	50~1100 (50mm increments)
RCS4CR-SA8C-WA-400-10-①-T2-②-③		10	80	678	
RCS4CR-SA8C-WA-400-5-①-T2-②-③		5	90	1357	

Legend: ① Stroke ② Cable Length ③ Option

### Stroke and Max Speed/Suction Amount

(Unit: mm/s)

Stroke / Lead	50~600	650	700	750	800	850	900	950	1000	1050	1100	Suction amount (N/min)
	(50mm increments)	(mm)	(mm)	(mm)	(mm)	(mm)	(mm)	(mm)	(mm)	(mm)	(mm)	
20	1200	1090	960	860	770	695	630	570	520	480	440	160
10	600	540	480	430	385	345	310	285	260	235	220	80
5	300	270	240	215	190	175	155	140	130	120	110	40

## Cable Length

Type	Cable Code
Standard	<b>P</b> (1m)
	<b>S</b> (3m)
	<b>M</b> (5m)
Specified length (Standard cable)	<b>X06</b> (6m) ~ <b>X10</b> (10m)
	<b>X11</b> (11m) ~ <b>X15</b> (15m)
	<b>X16</b> (16m) ~ <b>X20</b> (20m)
	<b>R01</b> (1m) ~ <b>R03</b> (3m)
Robot cable	<b>R04</b> (4m) ~ <b>R05</b> (5m)
	<b>R06</b> (6m) ~ <b>R10</b> (10m)
	<b>R11</b> (11m) ~ <b>R15</b> (15m)
	<b>R16</b> (16m) ~ <b>R20</b> (20m)

## Actuator Specifications

Item	Description
Drive system	Ball screw $\phi 16\text{mm}$ , rolled C10
Positioning repeatability (*1)	$\pm 0.01\text{mm}$ [ $\pm 0.005\text{mm}$ ]
Lost motion	0.1mm or less
Base	Material: Aluminum with white alumite treatment
Allowable static moment	Ma direction 219N·m, Mb direction 219N·m, Mc direction 414N·m
Allowable dynamic moment (*2)	Ma direction 77.0N·m, Mb direction 77.0N·m, Mc direction 146N·m
Cleanliness	ISO class 2.5 or equiv. (ISO STD 14644-1:2015), US class 10 (FED STD 209D)
Ambient operating temp. & humidity	0~40°C, 85% RH or less (Non-condensing)

(\*1) Values in [ ] are for high-precision (for lead 5/10/20) specification.  
 (\*2) Assumes a standard rated life of 5000km. The service life will vary depending on operation and installation conditions. Please contact IAI for details of the running life.

• Reference for overhang load length: Ma: 400mm or less, Mb, Mc: 400mm or less  
 Allowable load moment directions      Overhang load lengths

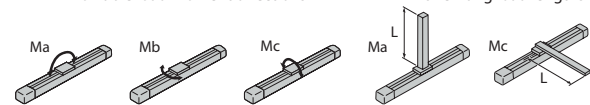

If the load moments in Ma/Mb/Mc direction are within the allowable ranges, there is no overhang load length limit.

Round cable joint connector with screw locking (*3)	<b>EU</b>	See P.131
---	-----------	-----------

## Options

Name	Option Code	Reference Page
Brake	<b>B</b>	See P.131
Cable exit direction (Top)	<b>CJT</b>	See P.131
Cable exit direction (Right)	<b>CJR</b>	See P.131
Cable exit direction (Left)	<b>CJL</b>	See P.131
Cable exit direction (Bottom)	<b>CJB</b>	See P.131
High-Precision specification (*1)	<b>HPR</b>	See P.134
Non-motor end specification	<b>NM</b>	See P.136
Air suction joint in opposite position	<b>VR</b>	See P.137
Double slider (*2)	<b>W</b>	See P.137

(\*1) Double slider cannot be selected. (\*2) Some leads cannot be selected. (Please see P. 150) (\*3) EU option will be available soon.

## Dimensions

CAD drawings can be downloaded from our website.  
www.robocylinder.de



\*1 When the slider is returning to its home position, please be careful of interference from surrounding objects, as it will travel until it reaches the M.E.  
M.E: Mechanical end S.E: Stroke end

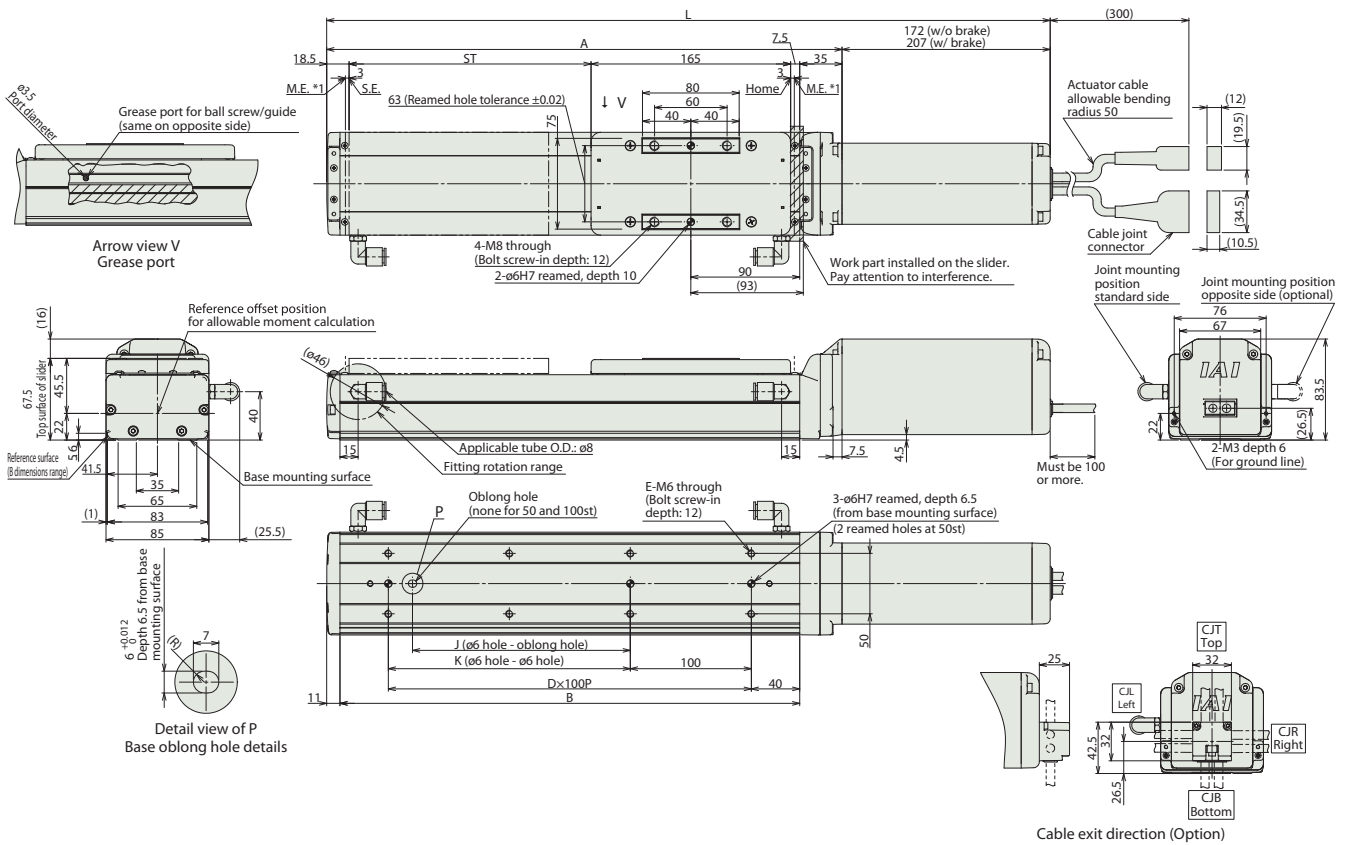

## Dimensions and Mass by Stroke

L	Stroke	50	100	150	200	250	300	350	400	450	500	550	600	650	700	750	800	850	900	950	1000	1050	1100
	W/o brake	448	498	548	598	648	698	748	798	848	898	948	998	1048	1098	1148	1198	1248	1298	1348	1398	1448	1498
W/ brake	483	533	583	633	683	733	783	833	883	933	983	1033	1083	1133	1183	1233	1283	1333	1383	1433	1483	1533	
A	276	326	376	426	476	526	576	626	676	726	776	826	876	926	976	1026	1076	1126	1176	1226	1276	1326	
B	230	280	330	380	430	480	530	580	630	680	730	780	830	880	930	980	1030	1080	1130	1180	1230	1280	
D	1	2	2	3	3	4	4	5	5	6	6	7	7	8	8	9	9	10	10	11	11	12	
E	4	6	6	8	8	10	10	12	12	14	14	16	16	18	18	20	20	22	22	24	24	26	
J	0	0	80	180	180	280	280	380	380	480	480	580	580	680	680	780	780	880	880	980	980	1080	
K	0	100	100	200	200	300	300	400	400	500	500	600	600	700	700	800	800	900	900	1000	1000	1100	
Mass (kg)	W/o brake	4.7	5.0	5.3	5.6	5.9	6.2	6.5	6.8	7.1	7.4	7.6	7.9	8.2	8.5	8.8	9.1	9.4	9.7	10.0	10.3	10.6	10.8
	W/ brake	5.2	5.5	5.8	6.1	6.4	6.7	7	7.3	7.6	7.9	8.1	8.4	8.7	9	9.3	9.6	9.9	10.2	10.5	10.8	11.1	11.3

## Applicable Controllers

The RCS4 series actuators can be operated by the controllers indicated below. Please select the type depending on your intended use.

Name	External view	Max. number of connectable axes	Input power	Control method				Maximum number of positioning points	Reference page
				Positioner	Pulse train	Program	Network * Option		
SCON-CB/CGB		1	Single phase 230VAC	●	●	—	DeviceNet CC-Link CompoNet EtherCAT EtherNet/IP	512 (768 for network spec.)	Please see P.151
SCON-LC/LCG (*)		1		—	—	●		512 (768 for network spec.)	
SSEL-CS		2	Single phase 115V/230VAC	●	—	●	Note: The type of compatible networks will vary depending on the controller. Please refer to the reference page for more information.	20000	Please see the dedicated controller catalog or manual.
XSEL-P/Q or XSEL-RA/SA (*)		6 or 8 (Depending on the type)	Single phase 230VAC Three-phase 230VAC	—	—	●		20000 or 55000 (Depending on the type)	

(\*) Coming soon

Foreword  
Slider Type  
Wide Slider Type  
Rod Type  
Radial Cylinder  
Wide Radial Cylinder  
Table Type  
Cleanroom Slider  
Cleanroom Wide Slider  
Options  
Reference Data  
Controller



## Dimensions

CAD drawings can be downloaded from our website.

www.robocylinder.de



\*1 When the slider is returning to its home position, please be careful of interference from surrounding objects, as it will travel until it reaches the M.E.  
M.E: Mechanical end S.E: Stroke end

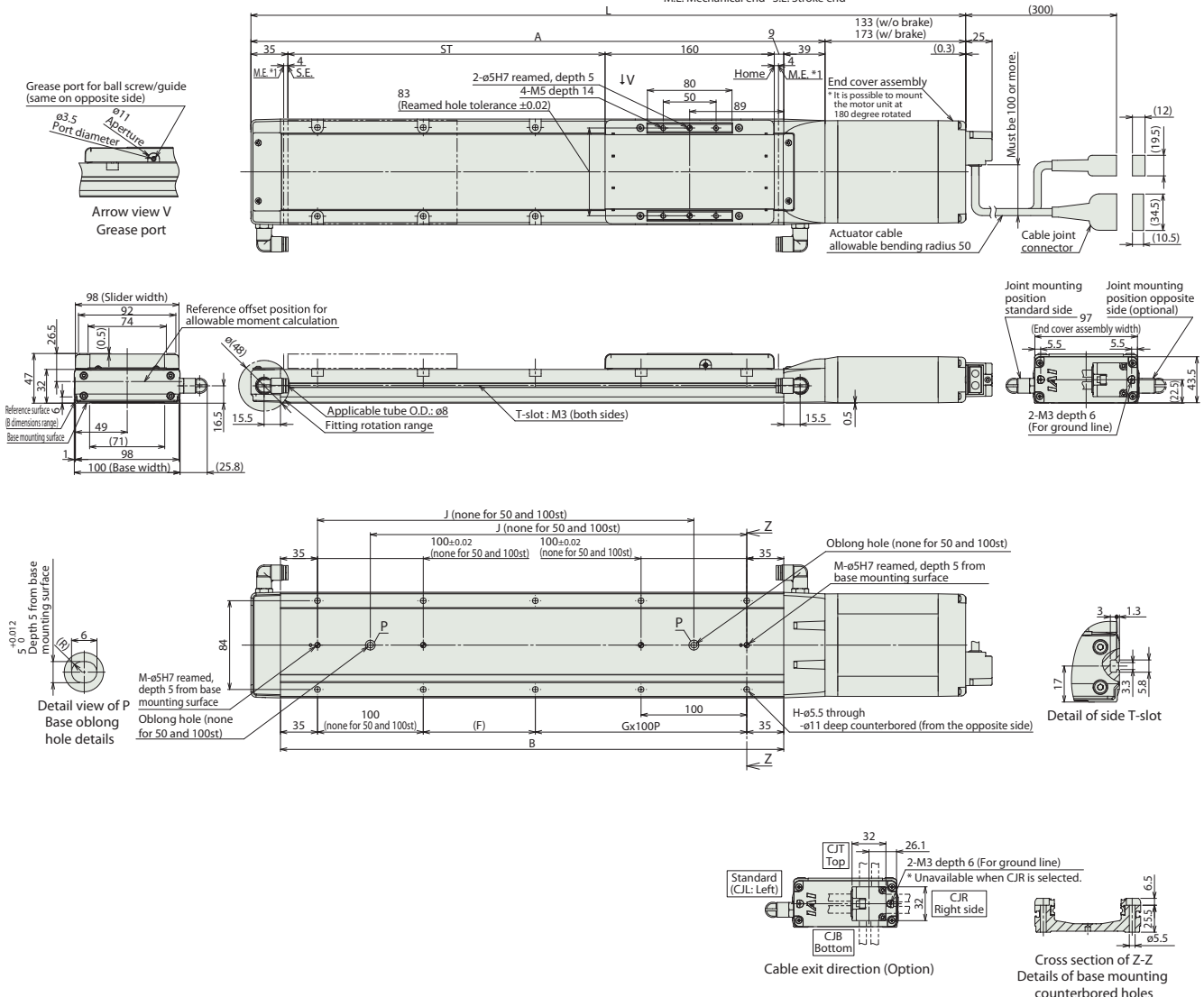

## Dimensions and Mass by Stroke

L	Stroke	50	100	150	200	250	300	350	400	450	500
	W/o brake	426	476	526	576	626	676	726	776	826	876
W/ brake	466	516	566	616	666	716	766	816	866	916	
A	293	343	393	443	493	543	593	643	693	743	
B	226	276	326	376	426	476	526	576	626	676	
F	156	206	256	306	356	406	456	506	556		
G	0	0	1	1	2	2	3	3	4	4	
H	4	4	8	8	10	10	12	12	14	14	
J	-	-	206	256	306	356	406	456	506	556	
M	1	1	2	2	2	2	2	2	2	2	
Mass (kg)	W/o brake	2.8	3.0	3.3	3.5	3.8	4.0	4.3	4.5	4.8	5.0
	W/ brake	3.1	3.3	3.6	3.8	4.1	4.3	4.6	4.8	5.1	5.3

## Applicable Controllers

The RCS4 series actuators can be operated by the controllers indicated below. Please select the type depending on your intended use.

Name	External view	Max. number of connectable axes	Input power	Control method				Maximum number of positioning points	Reference page
				Positioner	Pulse train	Program	Network * Option		
SCON-CB/CGB		1	Single phase 115V/230VAC	●	●	-	DeviceNet CCLink PROFINET CompoNet EtherCAT EtherNet/IP	512 (768 for network spec.)	Please see P.151
SCON-LC/LCG (*)		1		-	-	●		512 (768 for network spec.)	
SCON-CAL/CGAL		1		●	-	-		512 (768 for network spec.)	
MSCON-C		6		This model is network-compatible only.				256	
SSEL-CS		2		●	-	●	20000		
XSEL-P/Q or XSEL-RA/SA (*)		6 or 8 (Depending on the type)		Single phase 230VAC Three-phase 230VAC	-	-	●	20000 or 55000 (Depending on the type)	

Note: The type of compatible networks will vary depending on the controller. Please refer to the reference page for more information.

(\*) Coming soon

Foreword  
Slider Type  
Slider Type  
Wide Slider Type  
Rod Type  
Radial Cylinder  
Wide Radial Cylinder  
Table Type  
Cleanroom Slider  
Cleanroom Wide Slider  
Options  
Reference Data  
Controller

# RCS4CR-WSA12C



<b>Model Specification Items</b>	<b>RCS4CR</b> — <b>WSA12C</b> — <b>WA</b> — <b>100</b> — [ ] — [ ] — <b>T2</b> — [ ] — [ ]							
Series	Type	Encoder Type	Motor Type	Lead	Stroke	Applicable Controllers	Cable Length	Options
	WA: Battery-less Absolute	100: Servo motor 100W	20:20mm 12:12mm 6: 6mm 3: 3mm	50:50mm + 800:800mm (50mm increments)	T2:SCON MSCON SSEL XSEL-P/O XSEL-RA/SA	N : None P : 1m S : 3m M : 5m X□□ : Specified Length R□□ : Robot Cable	Refer to Options table below. * Be sure to select an option for the cable exit direction.	



\* Depending on the model, there may be some limitations to using the vertical, side, and ceiling mount positions. Please refer to the Selection Notes on P.138 for more information.

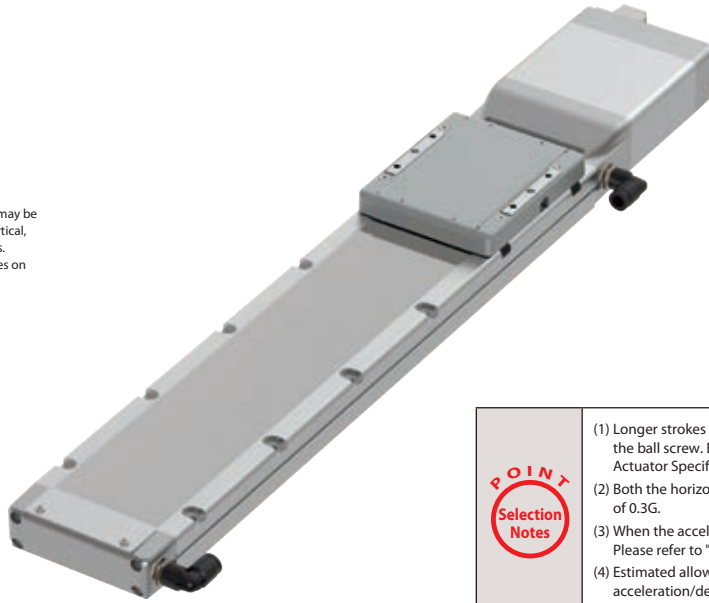

**POINT Selection Notes**

- (1) Longer strokes may cause the maximum speed to decrease due to resonance of the ball screw. Be sure to check the maximum speed of the desired stroke in the Actuator Specifications table, which can be found below.
- (2) Both the horizontal and vertical payloads assume operation at an acceleration of 0.3G.
- (3) When the acceleration is increased, the payload will be reduced. Please refer to "Table of Payload by Acceleration" on P.139 for more details.
- (4) Estimated allowable duty varies depending on operating conditions (payload, acceleration/deceleration, etc.). Please refer to P. 149 for more information.

## Actuator Specifications

### Lead and Payload

Model Number	Motor wattage (W)	Lead (mm)	Max. payload (kg)	Rated thrust (N)	Stroke (mm)
RCS4CR-WSA12C-WA-100-20-①-T2-②-③	100	20	15	85	50~800 (50mm increments)
RCS4CR-WSA12C-WA-100-12-①-T2-②-③		12	25	142	
RCS4CR-WSA12C-WA-100-6-①-T2-②-③		6	45	283	
RCS4CR-WSA12C-WA-100-3-①-T2-②-③		3	55	566	

Legend: ① Stroke ② Cable Length ③ Option

### Stroke and Max Speed/Suction Amount

(Unit: mm/s)

Stroke	50~450	500	550	600	650	700	750	800	Suction amount (N/mm)
Lead	(50mm increments)								
20	1200	1130	970	840	740	650	580	520	140
12	720	610	535	465	405	355	315	285	90
6	360	310	265	230	200	175	155	140	60
3	180	150	130	115	100	85	75	70	50

## Cable Length

Type	Cable Code
Standard	P (1m)
	S (3m)
	M (5m)
Specified length (Standard cable)	X06 (6m) ~ X10 (10m)
	X11 (11m) ~ X15 (15m)
	X16 (16m) ~ X20 (20m)
Robot cable	R01 (1m) ~ R03 (3m)
	R04 (4m) ~ R05 (5m)
	R06 (6m) ~ R10 (10m)
	R11 (11m) ~ R15 (15m)
	R16 (16m) ~ R20 (20m)

## Actuator Specifications

Item	Description
Drive system	Ball screw ø10mm, rolled C10
Positioning repeatability (*1)	±0.01mm [±0.005mm]
Lost motion	0.1mm or less
Base	Material: Aluminum with white alumite treatment
Allowable static moment	Ma direction 311N·m, Mb direction 311N·m, Mc direction 827N·m
Allowable dynamic moment (*2)	Ma direction 87.5N·m, Mb direction 87.5N·m, Mc direction 233N·m
Cleanliness	ISO class 2.5 or equiv. (ISO STD 14644-1:2015), US class 10 (FED STD 209D)
Ambient operating temp. & humidity	0~40°C, 85% RH or less (Non-condensing)

(\*1) Values in [ ] are for high-precision specification.  
(\*2) Assumes a standard rated life of 5000km. The service life will vary depending on operation and installation conditions. Please contact IAI for details of the running life.

• Reference for overhang load length: Ma: 450mm or less, Mb, Mc: 450mm or less

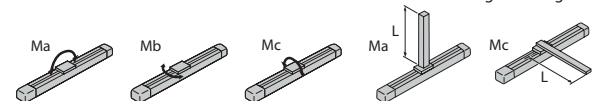

If the load moments in Ma/Mb/Mc direction are within the allowable ranges, there is no overhang load length limit.

Round cable joint connector with screw locking (*1)	<b>EU</b>	See P.131
---	-----------	-----------

## Options

Name	Option Code	Reference Page
Brake	<b>B</b>	See P.131
Cable exit direction (Top)	<b>CJT</b>	See P.131
Cable exit direction (Right)	<b>CJR</b>	See P.131
Cable exit direction (Left)	<b>CJL</b>	See P.131
Cable exit direction (Bottom)	<b>CJB</b>	See P.131
High-precision specification	<b>HPR</b>	See P.134
Non-motor end specification	<b>NM</b>	See P.136
Air suction joint in opposite position	<b>VR</b>	See P.137

(\*1) EU option will be available soon.



# RCS4CR-WSA14C

$\pm 10\mu\text{m}$ Standard	$\pm 5\mu\text{m}$ Optional	Clean-room Spec.	Battery-less Absolute	Motor Unit Coupled	Straight Motor	Body Width <b>140mm</b>	<b>230v</b> AC Servo Motor
---------------------------------	--------------------------------	------------------	-----------------------	--------------------	----------------	----------------------------	-------------------------------

<b>Model Specification Items</b>	<b>RCS4CR</b> — <b>WSA14C</b> — <b>WA</b> — <b>200</b>	<b>T2</b>						
Series	Type	Encoder Type	Motor Type	Lead	Stroke	Applicable Controllers	Cable Length	Options
	WA: Battery-less Absolute	200: Servo Motor 200W	24:24mm 16:16mm 8: 8mm 4: 4mm	50:50mm ± 800:800mm (50mm increments)	T2: SCON MSCON SSEL XSEL-P/O XSEL-RA/SA	N : None P : 1m S : 3m M : 5m X□□ : Specified Length R□□ : Robot Cable	Refer to Options table below. * Be sure to select an option for the cable exit direction.	

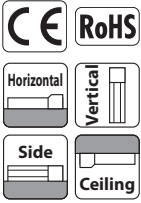

\* Depending on the model, there may be some limitations to using the vertical, side, and ceiling mount positions. Please refer to the Selection Notes on P.138 for more information.

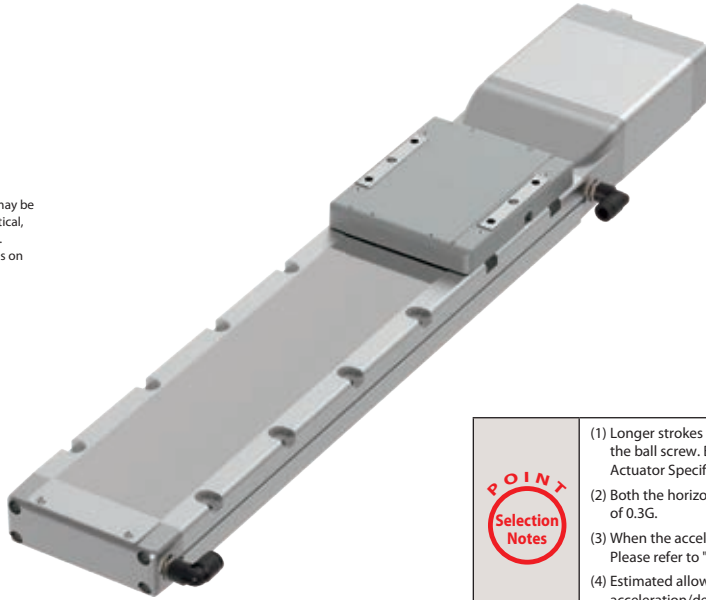

- (1) Longer strokes may cause the maximum speed to decrease due to resonance of the ball screw. Be sure to check the maximum speed of the desired stroke in the Actuator Specifications table, which can be found below.
- (2) Both the horizontal and vertical payloads assume operation at an acceleration of 0.3G.
- (3) When the acceleration is increased, the payload will be reduced. Please refer to "Table of Payload by Acceleration" on P.139 for more details.
- (4) Estimated allowable duty varies depending on operating conditions (payload, acceleration/deceleration, etc.). Please refer to P. 149 for more information.

## Actuator Specifications

### Lead and Payload

Model Number	Motor wattage (W)	Lead (mm)	Max. payload (kg)	Rated thrust (N)	Stroke (mm)
RCS4CR-WSA14C-WA-200-24-①-T2-②-③	200	24	20	142	50~800 (50mm increments)
RCS4CR-WSA14C-WA-200-16-①-T2-②-③		16	45	214	
RCS4CR-WSA14C-WA-200-8-①-T2-②-③		8	65	427	
RCS4CR-WSA14C-WA-200-4-①-T2-②-③		4	80	855	

Legend: ① Stroke ② Cable Length ③ Option

### Stroke and Max Speed/Suction Amount (Unit: mm/s)

Stroke (50mm increments)	50~450 (mm)	500 (mm)	550 (mm)	600 (mm)	650 (mm)	700 (mm)	750 (mm)	800 (mm)	Suction amount (Nl/min)
24	1440	1420	1220	1060	930	830	740	665	140
16	960	920	790	690	610	550	490	440	110
8	480	460	400	350	305	270	240	215	80
4	240	230	200	170	150	135	120	105	75

## Cable Length

Type	Cable Code
Standard	P (1m)
	S (3m)
	M (5m)
Specified length (Standard cable)	X06 (6m) ~ X10 (10m)
	X11 (11m) ~ X15 (15m)
	X16 (16m) ~ X20 (20m)
	R01 (1m) ~ R03 (3m)
Robot cable	R04 (4m) ~ R05 (5m)
	R06 (6m) ~ R10 (10m)
	R11 (11m) ~ R15 (15m)
	R16 (16m) ~ R20 (20m)

## Actuator Specifications

Item	Description
Drive system	Ball screw $\phi 12\text{mm}$ , rolled C10
Positioning repeatability (*1)	$\pm 0.01\text{mm}$ [ $\pm 0.005\text{mm}$ ]
Lost motion	0.1mm or less
Base	Material: Aluminum with white alumite treatment
Allowable static moment	Ma direction 462N·m, Mb direction 462N·m, Mc direction 1170N·m
Allowable dynamic moment (*2)	Ma direction 122N·m, Mb direction 122N·m, Mc direction 308N·m
Cleanliness	ISO class 2.5 or equiv. (ISO STD 14644-1:2015), US class 10 (FED STD 209D)
Ambient operating temp. & humidity	0~40°C, 85% RH or less (Non-condensing)

(\*1) Values in [ ] are for high-precision (for lead 4/8/16) specification.  
(\*2) Assumes a standard rated life of 5000km. The service life will vary depending on operation and installation conditions. Please contact IAI for details of the running life.

• Reference for overhang load length: Ma: 550mm or less, Mb, Mc: 550mm or less

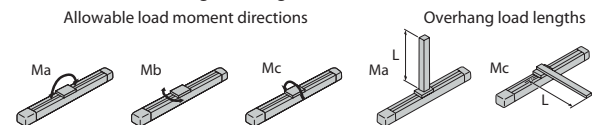

If the load moments in Ma/Mb/Mc direction are within the allowable ranges, there is no overhang load length limit.

Round cable joint connector with screw locking (*2)	<b>EU</b>	See P.131
---	-----------	-----------

## Options

Name	Option Code	Reference Page
Brake	<b>B</b>	See P.131
Cable exit direction (Top)	<b>CJT</b>	See P.131
Cable exit direction (Right)	<b>CJR</b>	See P.131
Cable exit direction (Left)	<b>CJL</b>	See P.131
Cable exit direction (Bottom)	<b>CJB</b>	See P.131
High-precision specification (*1)	<b>HPR</b>	See P.134
Non-motor end specification	<b>NM</b>	See P.136
Air suction joint in opposite position	<b>VR</b>	See P.137

(\*1) When the lead is 24, it cannot be selected. (\*2) EU option will be available soon.





# RCS4CR-WSA16C



Model Specification Items	<b>RCS4CR</b> — <b>WSA16C</b> — <b>WA</b> — <b>400</b> — [ ] — [ ] — [ ] — <b>T2</b> — [ ] — [ ]
	Series — Type — Encoder Type — Motor Type — Lead — Stroke — Applicable Controllers — Cable Length — Options
	WA: Battery-less Absolute      400: Servo motor 400W      20:20mm 10:10mm 5: 5mm      50:50mm + 1100:1100mm (50mm increments)      T2: SCON SSEL XSEL-P/Q XSEL-RA/SA      N: None P: 1m S: 3m M: 5m      Refer to Options table below. * Be sure to select an option for the cable exit direction. X [ ] : Specified Length R [ ] : Robot Cable

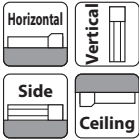

\* Depending on the model, there may be some limitations to using the vertical, side, and ceiling mount positions. Please refer to the Selection Notes on P.138 for more information.

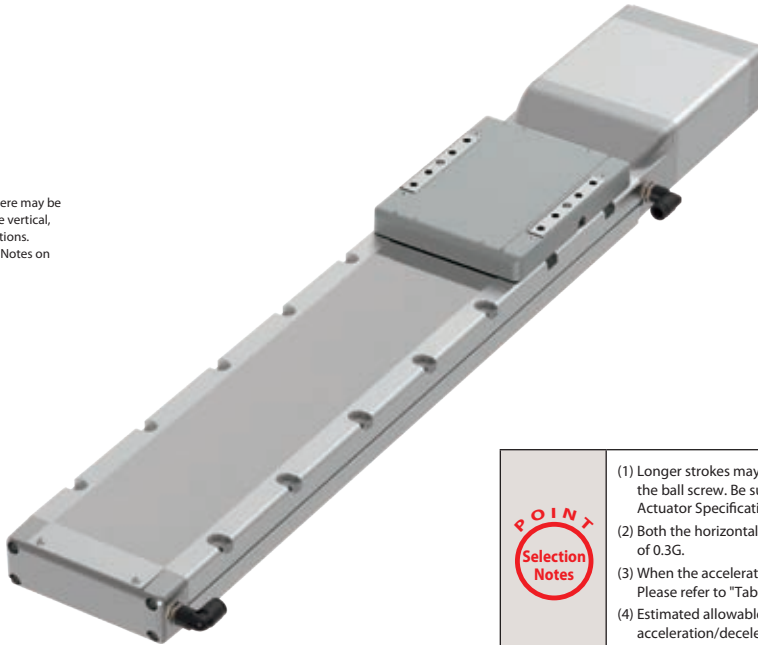

- Longer strokes may cause the maximum speed to decrease due to resonance of the ball screw. Be sure to check the maximum speed of the desired stroke in the Actuator Specifications table, which can be found below.
- Both the horizontal and vertical payloads assume operation at an acceleration of 0.3G.
- When the acceleration is increased, the payload will be reduced. Please refer to "Table of Payload by Acceleration" on P.139 for more details.
- Estimated allowable duty varies depending on operating conditions (payload, acceleration/deceleration, etc.). Please refer to P. 149 for more information.

## Actuator Specifications

### Lead and Payload

Model Number	Motor wattage (W)	Lead (mm)	Max. payload		Rated thrust (N)	Stroke (mm)
			Horizontal (kg)	Vertical (kg)		
RCS4CR-WSA16C-WA-400-20-①-T2-②-③	400	20	60	20	339	50~1100 (50mm increments)
RCS4CR-WSA16C-WA-400-10-①-T2-②-③		10	80	35	678	
RCS4CR-WSA16C-WA-400-5-①-T2-②-③		5	100	50	1357	

Legend: ① Stroke ② Cable Length ③ Option

### Stroke and Max Speed/Suction Amount

(Unit: mm/s)

Stroke	Lead											Suction amount (N/Case)	
	50~550 (50mm increments)	600	650	700	750	800	850	900	950	1000	1050		1100
20	1200	1120	990	880	780	715	645	590	535	490	450	415	130
10	600	560	490	440	395	355	320	290	265	240	225	205	90
5	300	280	240	220	195	175	160	145	130	120	110	100	85

## Cable Length

Type	Cable Code
Standard	P (1m)
	S (3m)
	M (5m)
Specified length (Standard cable)	X06 (6m) ~ X10 (10m)
	X11 (11m) ~ X15 (15m)
	X16 (16m) ~ X20 (20m)
	R01 (1m) ~ R03 (3m)
Robot cable	R04 (4m) ~ R05 (5m)
	R06 (6m) ~ R10 (10m)
	R11 (11m) ~ R15 (15m)
	R16 (16m) ~ R20 (20m)

## Actuator Specifications

Item	Description
Drive system	Ball screw ø16mm, rolled C10
Positioning repeatability (*1)	±0.01mm [±0.005mm]
Lost motion	0.1mm or less
Base	Material: Aluminum with white alumite treatment
Allowable static moment	Ma direction 642N·m, Mb direction 642N·m, Mc direction 1610N·m
Allowable dynamic moment (*2)	Ma direction 161N·m, Mb direction 161N·m, Mc direction 404N·m
Cleanliness	ISO class 2.5 or equiv. (ISO STD 14644-1:2015), US class 10 (FED STD 209D)
Ambient operating temp. & humidity	0~40°C, 85% RH or less (Non-condensing)

(\*1) Values in [ ] are for high-precision (for lead 5/10/20) specification.  
 (\*2) Assumes a standard rated life of 5000km. The service life will vary depending on operation and installation conditions. Please contact IAI for details of the running life.

• Reference for overhang load length: Ma: 650mm or less, Mb, Mc: 650mm or less  
 Allowable load moment directions      Overhang load lengths

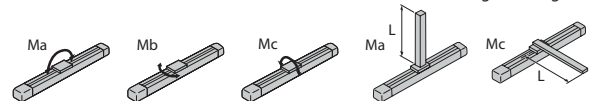

If the load moments in Ma/Mb/Mc direction are within the allowable ranges, there is no overhang load length limit.

## Options

Name	Option Code	Reference Page
Brake	B	See P.131
Cable exit direction (Top)	CJT	See P.131
Cable exit direction (Right)	CJR	See P.131
Cable exit direction (Left)	CJL	See P.131
Cable exit direction (Bottom)	CJB	See P.131
High-precision specification	HPR	See P.134
Non-motor end specification	NM	See P.136
Air suction joint in opposite position	VR	See P.137

(\*1) EU option will be available soon.

Round cable joint connector with screw locking (*1)	EU	See P.131
---	----	-----------

## Dimensions

CAD drawings can be downloaded from our website.

www.robocylinder.de



\*1 When the slider is returning to its home position, please be careful of interference from surrounding objects, as it will travel until it reaches the M.E.  
M.E: Mechanical end S.E: Stroke end

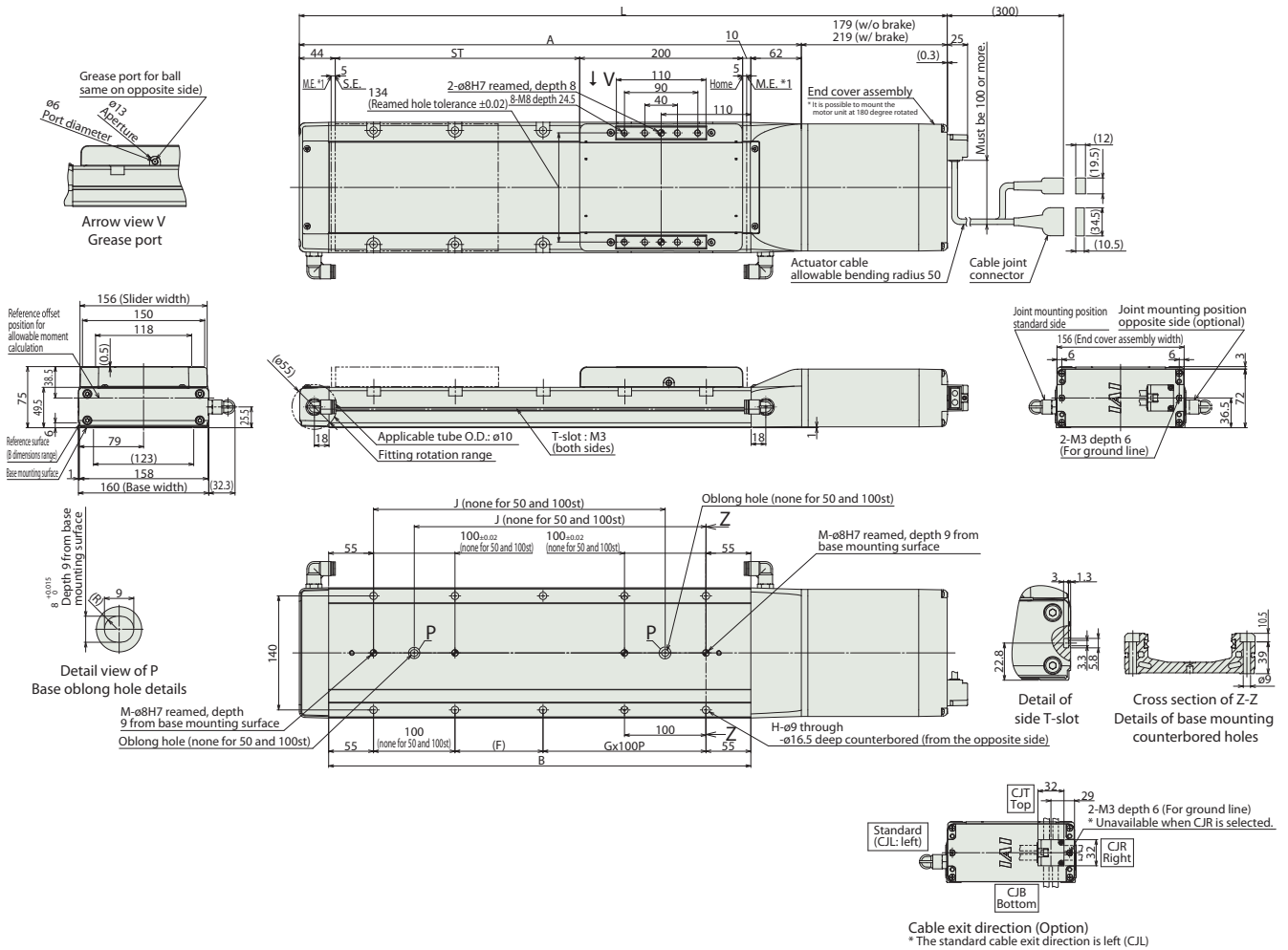

## Dimensions and Mass by Stroke

L	Stroke	50	100	150	200	250	300	350	400	450	500	550	600	650	700	750	800	850	900	950	1000	1050	1100
	W/o brake	545	595	645	695	745	795	845	895	945	995	1045	1095	1145	1195	1245	1295	1345	1395	1445	1495	1545	1595
W/ brake	585	635	685	735	785	835	885	935	985	1035	1085	1135	1185	1235	1285	1335	1385	1435	1485	1535	1585	1635	
A	366	416	466	516	566	616	666	716	766	816	866	916	966	1016	1066	1116	1166	1216	1266	1316	1366	1416	
B	268	318	368	418	468	518	568	618	668	718	768	818	868	918	968	1018	1068	1118	1168	1218	1268	1318	
F	158	208	258	308	358	408	458	508	558	608	658	708	758	808	858	908	958	1008	1058	1108	1158		
G	0	0	1	1	2	2	3	3	4	4	5	5	6	6	7	7	8	8	9	9	10	10	
H	4	4	8	8	10	10	12	12	14	14	16	16	18	18	20	20	22	22	24	24	26	26	
J	-	-	208	258	308	358	408	458	508	558	608	658	708	758	808	858	908	958	1008	1058	1108	1158	
M	1	1	2	2	2	2	2	2	2	2	2	2	2	2	2	2	2	2	2	2	2	2	
Mass (kg)	W/o brake	9.1	9.8	10.4	11.0	11.6	12.2	12.8	13.4	14.0	14.7	15.3	15.9	16.5	17.1	17.7	18.3	18.9	19.5	20.2	20.8	21.4	22.0
	W/ brake	9.7	10.4	11.0	11.6	12.2	12.8	13.4	14.0	14.6	15.3	15.9	16.5	17.1	17.7	18.3	18.9	19.5	20.2	20.8	21.4	22.0	

## Applicable Controllers

The RCS4 series actuators can be operated by the controllers indicated below. Please select the type depending on your intended use.

Name	External view	Max. number of connectable axes	Input power	Control method				Maximum number of positioning points	Reference page
				Positioner	Pulse train	Program	Network * Option		
SCON-CB/CGB		1	Single phase 230VAC	●	●	-	DeviceNet CC-Link CompoNet EtherCAT EtherNet/IP	512 (768 for network spec.)	Please see P.151
SCON-LC/LCG (*)		1		-	-	●		512 (768 for network spec.)	
SSEL-CS		2	Single phase 115V/230VAC	●	-	●	Note: The type of compatible networks will vary depending on the controller. Please refer to the reference page for more information.	20000	Please see the dedicated controller catalog or manual.
XSEL-P/Q or XSEL-RA/SA (*)		6 or 8 (Depending on the type)	Single phase 230VAC Three-phase 230VAC	-	-	●		20000 or 55000 (Depending on the type)	

(\*) Coming soon

Foreword  
 Slider Type  
 Wide Slider Type  
 Rod Type  
 Radial Cylinder  
 Wide Radial Cylinder  
 Table Type  
 Cleanroom Slider  
 Cleanroom Wide Slider  
 Options  
 Reference Data  
 Controller

# RCS4 Series Options

## Brake

**Model B**

**Description** When the actuator is mounted vertically, this works as a holding mechanism that prevents the slider, rod, or table from falling and damaging any attachments when the power or servo is turned off.

## Cable exit direction

**Model CJT / CJR / CJL / CJB / CJO**

**Description** This option allows you to change the exit direction of the motor-encoder cable to top, bottom, left, or right.

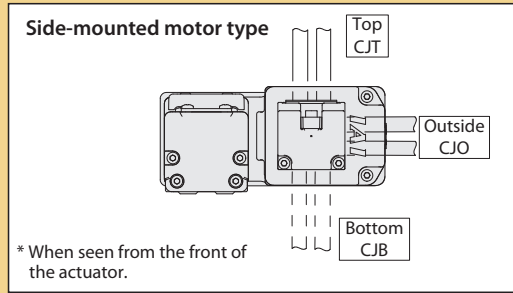
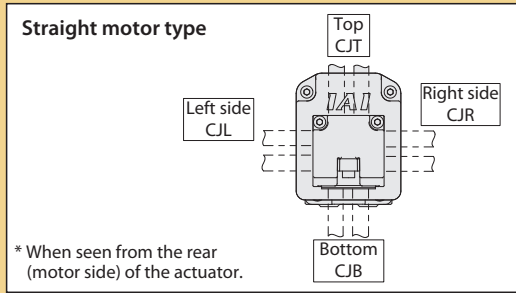

## Round cable joint connector with screw locking

**Model EU**

**Description** Option for a motor/encoder cable with round cable plugs with screw locking. Without this option flat plugs are default.

## Tip adapter (Flange)

**Model FFA**

**Description** A rod tip tooling adapter with 4 threaded holes.

RCS4-RR4□  
Model Name: RCP6-FFA-RR4

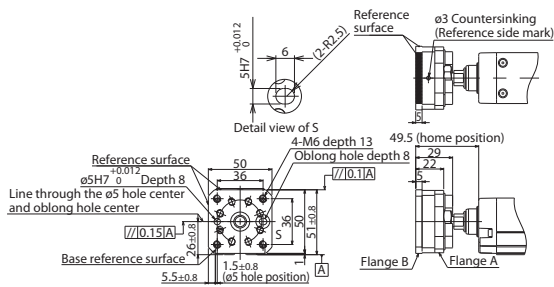

RCS4-RR6□  
Model Name: RCP6-FFA-RR6

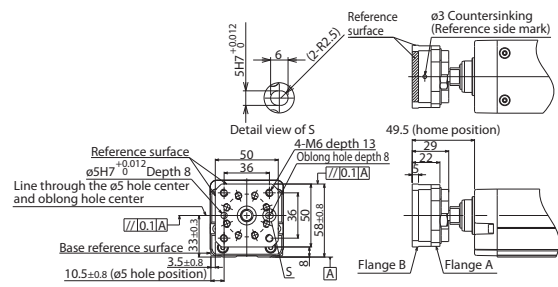

RCS4-RR7□  
Model Name: RCP6-FFA-RR7

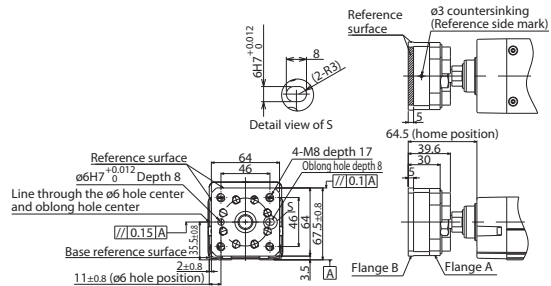

Flange

Model **FL**

Description A bracket that attaches to the actuator body with bolts. \* Be sure to confirm with the Selection Notes (P.138).

RCS4-RA4□

Model Name: RCP6-FL-RA4

\* Furnished separately.  
The assembly is to be performed by the customer with reference to the mechanical drawings.

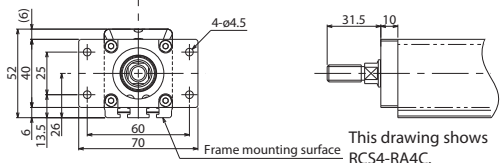

RCS4-RA6□

Model Name: RCP6-FL-RA6

\* Furnished separately.  
The assembly is to be performed by the customer with reference to the mechanical drawings.

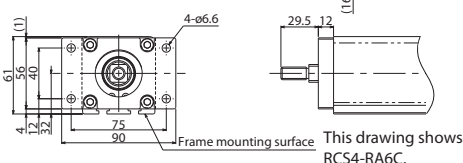

RCS4-RA7□

Model Name: RCP6-FL-RA7

\* Furnished separately.  
The assembly is to be performed by the customer with reference to the mechanical drawings.

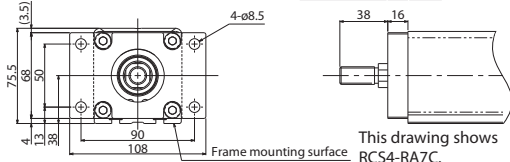

RCS4-RA8□

Model Name: RCP6-FL-RA8

\* Furnished separately.  
The assembly is to be performed by the customer with reference to the mechanical drawings.

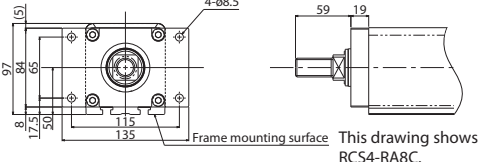

RCS4-RAA4□

Model Name: RCP6-FL-RAA4

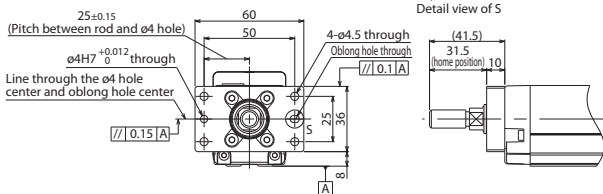

RCS4-RAA6□

Model Name: RCP6-FL-RAA6

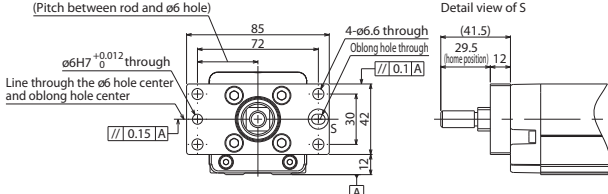

RCS4-RAA7□

Model Name: RCP6-FL-RAA7

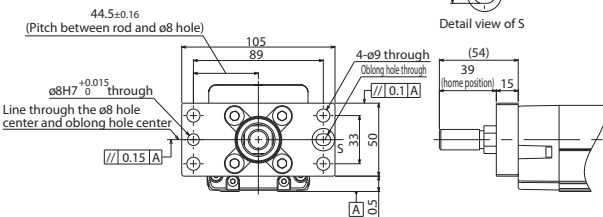

RCS4-RAA8□

Model Name: RCP6-FL-RAA8

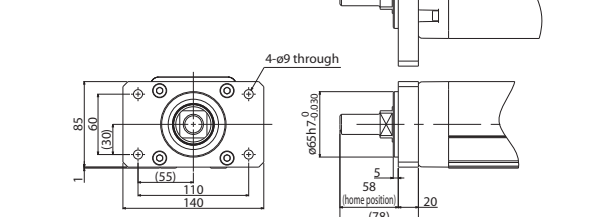

RCS4-WRA10□

Model Name: RCP6-FL-WRA10

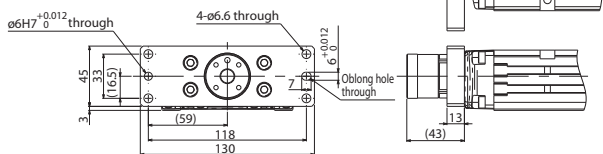

RCS4-WRA12□

Model Name: RCP6-FL-WRA12

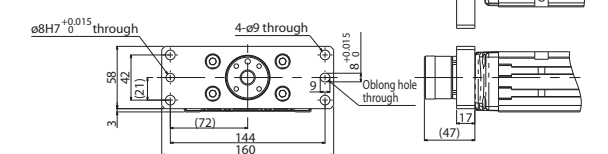

Foreword  
Slider Type  
Wide Slider Type  
Rod Type  
Radial Cylinder  
Wide Radial Cylinder  
Table Type  
Cleanroom Slider  
Cleanroom Wide Slider  
Options  
Reference Data  
Controller

RCS4-WRA14□  
Model Name: RCP6-FL-WRA14

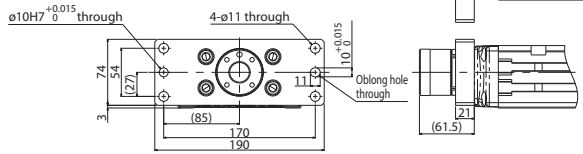

RCS4-WRA16□  
Model Name: RCP6-FL-WRA16

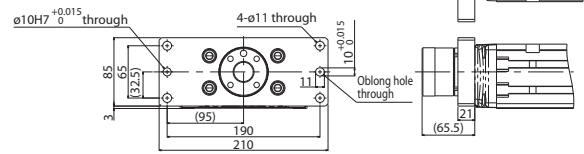

## Foot bracket

Model **FT**

**Description** This is a bracket used to fix the actuator with bolts from the top side. (Bolts are tightened from the top, not from the bottom) For slider type actuators, when the moment load is large, please attach the foot brackets on all the mounting holes on the actuator. The actuator body may be twisted or deformed if insufficient mounting foot brackets are used. Actuator life could also be shortened. \* Refer to the installation dimensions in the actuator drawing for the installation pitch between the foot brackets.

RCS4-RA4C  
Model Name: RCP6-FT-RA4C

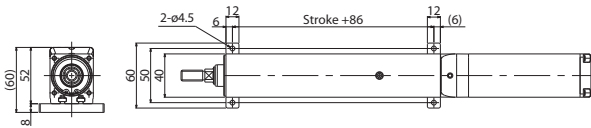

RCS4-RA6C  
Model Name: RCP6-FT-RA6C

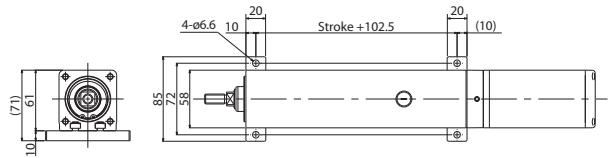

RCS4-RA7C  
Model Name: RCP6-FT-RA7C

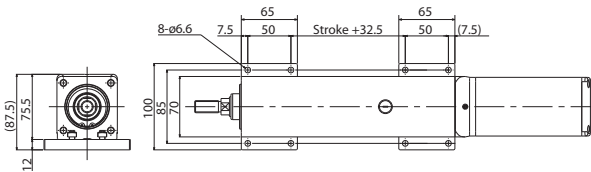

RCS4-RA8C  
Model Name: RCP6-FT-RA8C

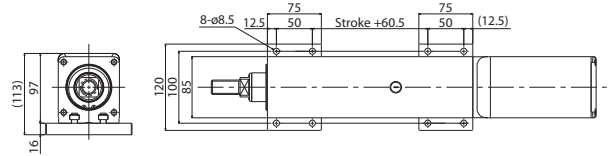

RCS4-RA4R  
Model Name: RCP6-FT-RA4R-3 (For the motor side-mounted to the right/left)

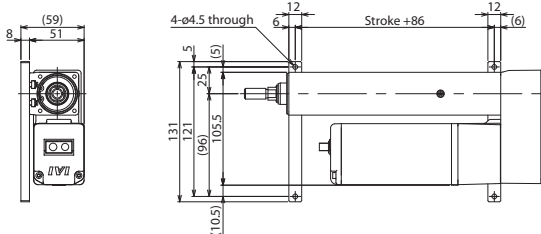

RCS4-RA6R  
Model Name: RCP6-FT-RA6R (For the motor side-mounted to the right/left)

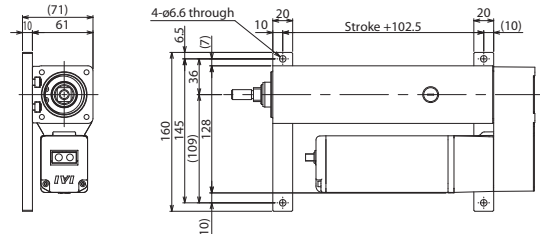

RCS4-RA7R  
Model Name: RCP6-FT-RA7R (For the motor side-mounted to the right/left)

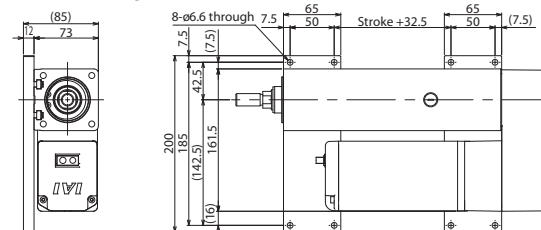

RCS4-RA8R  
Model Name: RCP6-FT-RA8R-2 (For the motor side-mounted to the right/left)

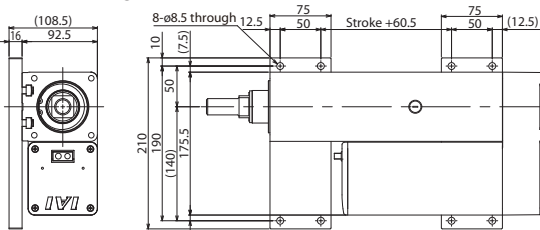

High-precision Specification

Model **HPR**

Description The positioning repeatability of the standard specification of the slider and wide slider types is  $\pm 0.01\text{mm}$ .  
If this option is selected, the positioning repeatability can be  $\pm 0.005\text{mm}$ . \* This option can be selected for actuators with lead 20mm or less.

Tip adapter (Keyway)

Model **KFA**

Description A rod tip adapter with 1 threaded hole and a parallel keyway.

RCS4-RR4□

Model Name: RCP6-KFA-RR4

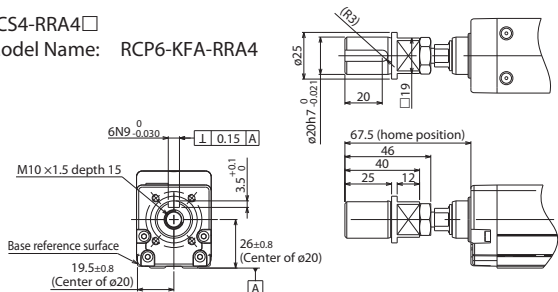

RCS4-RR6□

Model Name: RCP6-KFA-RR6

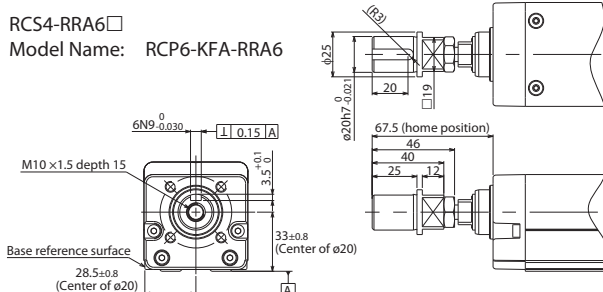

RCS4-RR7□

Model Name: RCP6-KFA-RR7

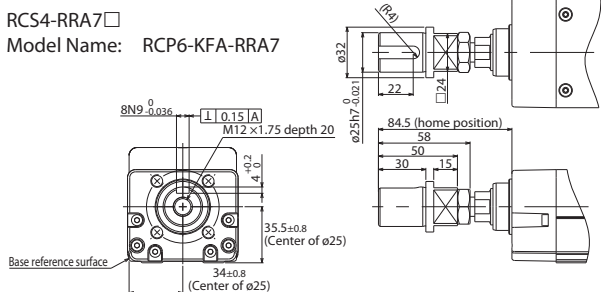

- Foreword
- Slider Type
- Wide Slider Type
- Rod Type
- Radial Cylinder
- Wide Radial Cylinder
- Table Type
- Cleanroom Slider
- Cleanroom Wide Slider
- Options
- Reference Data
- Controller

## Side-mounted motor direction

**Model** ML / MR

**Description** This allows you to specify the direction of the side-mounted motor type.  
As viewed from the motor side of the actuator, side-mounting to left is ML and right is MR.



## Tip adapter (Internal thread)

**Model** NFA

**Description** A rod tip tooling adapter with 1 threaded hole.

RCS4-RA4□

Model Name: RCP6-NFA-RA4

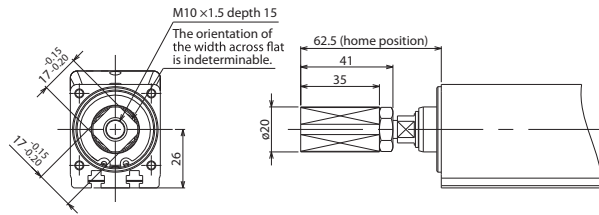

RCS4-RA6□

Model Name: RCP6-NFA-RA6

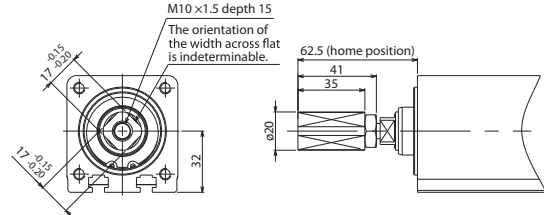

RCS4-RA7□

Model Name: RCP6-NFA-RA7

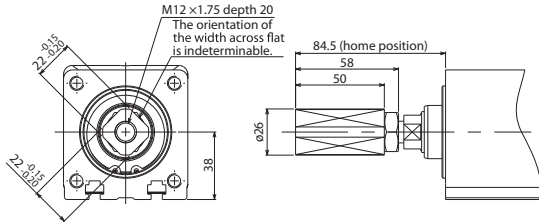

RCS4-RA8□

Model Name: RCP6-NFA-RA8

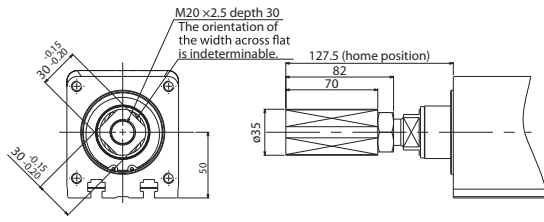

RCS4-RAA4□

Model Name: RCP6-NFA-RAA4

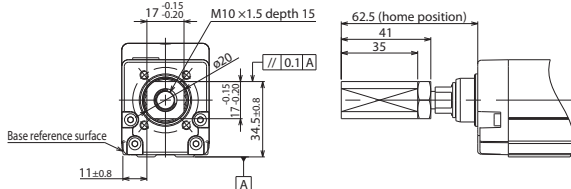

RCS4-RAA6□

Model Name: RCP6-NFA-RAA6

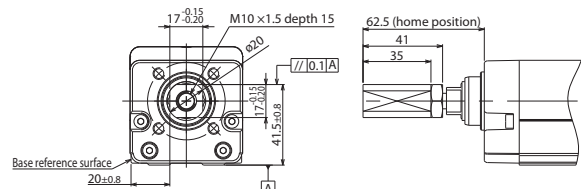

RCS4-RAA7□

Model Name: RCP6-NFA-RAA7

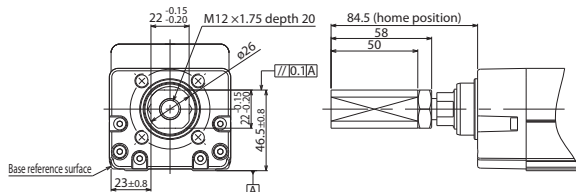

RCS4-RAA8□

Model Name: RCP6-NFA-RAA8

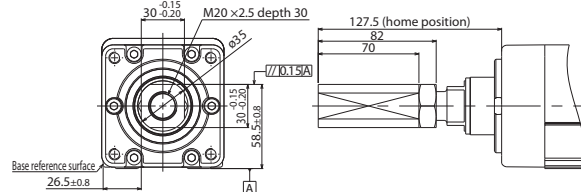



## Non-motor End Specification

Model **NM**

**Description** The standard specification home position is set by the slider, rod, and table on the motor side, but there is the option for the home position to be on the other side to accommodate variations in equipment layout, etc. (Please note that changing the home position after the actuator is manufactured and shipped from the factory may require the products to be sent back to IAI for re-setting.)

## T-slot nut bar

Model **NTB / NTBL / NTBR**

**Description** T-slot nut bar is a bar-shaped bracket which is to be inserted into the actuator's T-slot. There are tapped mounting holes on the T-slot nut bar. From the motor-side view, NTBL is inserted on the left side, and NTBR is inserted on the right.

\* Only NTB can be selected for Rod type (RA), while either NTBL (for the actuator with its motor side-mounted to the right) or NTBR (for the actuator with its motor side-mounted to the left) can be selected for wide radial cylinder (WRA).

RCS4-RA4□  
Model Name: RCP6-NTB-RA4

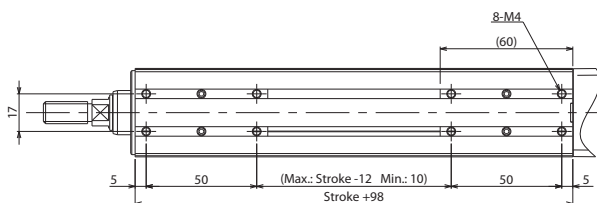

RCS4-RA6□  
Model Name: RCP6-NTB-RA6

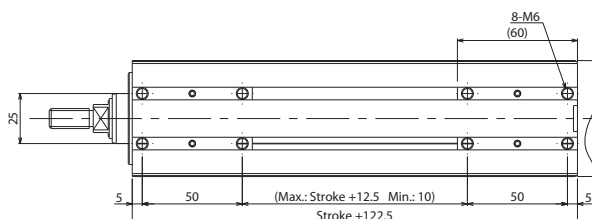

RCS4-RA7□  
Model Name: RCP6-NTB-RA7

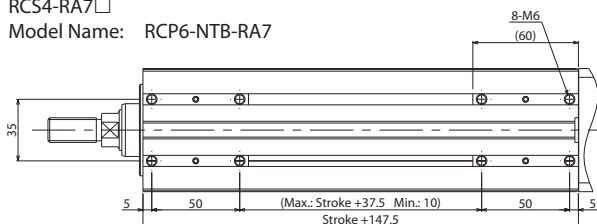

RCS4-RA8□  
Model Name: RCP6-NTB-RA8

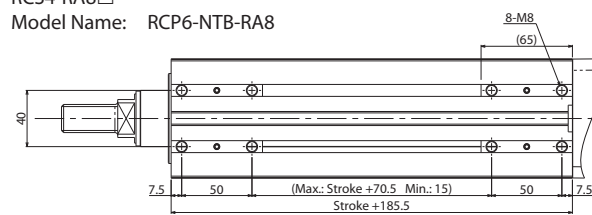

RCS4-WRA10□  
Model Name: RCP6-NTB-WRA10

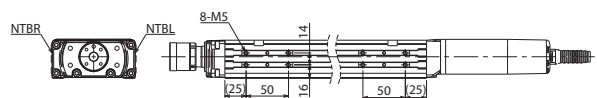

RCS4-WRA12□  
Model Name: RCP6-NTB-WRA12

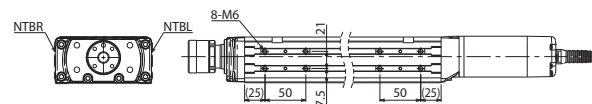

RCS4-WRA14□  
Model Name: RCP6-NTB-WRA14

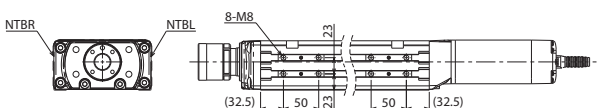

RCS4-WRA16□  
Model Name: RCP6-NTB-WRA16

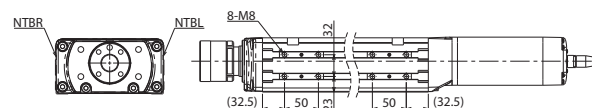

Foreword

Slider Type

Wide Slider Type

Rod Type

Radial Cylinder

Wide Radial Cylinder

Table Type

Cleanroom Slider

Cleanroom Wide Slider

Options

Reference Data

Controller

## Back mounting plate

**Model** RP

**Description** A metal bracket (plate) for fixing the back of the side-mounted motor type to equipment.  
\* Please refer to product specification pages for drawings.

## Slider Roller Specification

**Model** SR

**Description** Changes the slider structure of the standard slider type to the same roller structure of the cleanroom specification. Changing to roller specification will make the external view and dimensions of the slider cover the same as the cleanroom specification.

## Slider spacer

**Model** SS

**Description** This option changes the top of the slider position to be higher than the motor height.

RCS4-SA4R  
Model Name: RCS4-SS-SA4

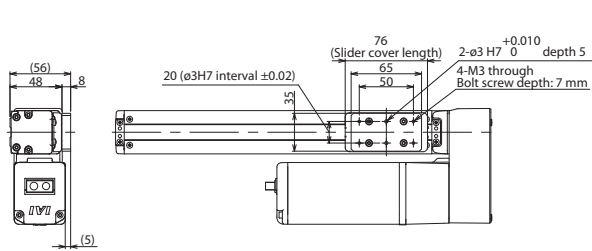

RCS4-SA7R  
Model Name: RCP6-SS-SA7

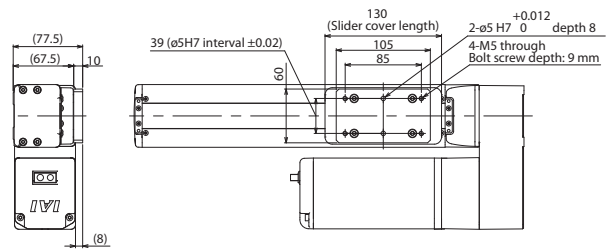

RCS4-SA8R  
Model Name: RCP6-SS-SA8

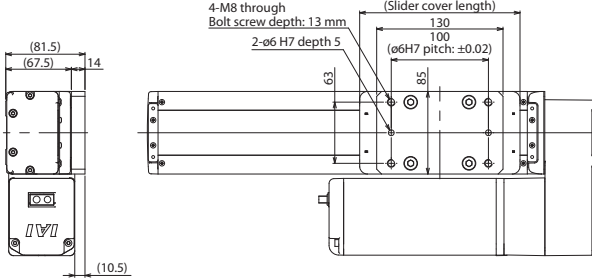

RCS4-WSA10R  
Model Name: RCS4-SS-WSA10

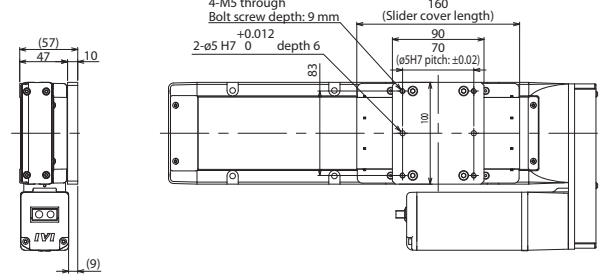

RCS4-WSA14R  
Model Name: RCS4-SS-WSA14

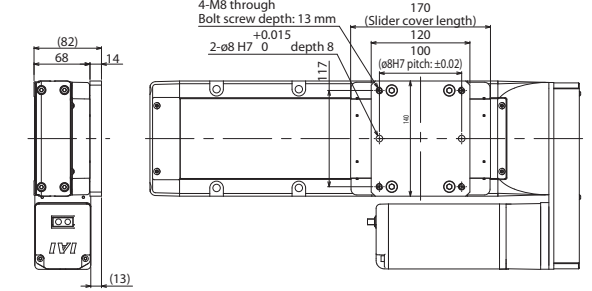

## Vacuum joint mounting position opposite

**Model** VR

**Description** As standard, the vacuum joint is installed on the left side of the body when seen from the motor side, but this option changes it to the right side (opposite side).

## Double Slider

**Model** W

**Description** This option adds a free slider not connected to the ball screw or drive belt. Using a double slider enables increased moment and overhang load length.  
\* For the allowable dynamic moment and overhang load length of the double slider, refer to P.150.

# Selection Notes for RCS4 Series

## ■ Cautions When Selecting the Rod Attachment Option

Model	Options			Model	Options			Model	Options		
RCS4	FL	NTBL	NTBR	RCS4	FL	NTBL	NTBR	RCS4	FL	NTBL	NTBR
RA4R	①	—	—	RRA4R	③	—	—	WRA10R	②	⑥	⑦
RA6R	①	—	—	RRA6R	④	—	—	WRA12R	②	⑥	⑦
RA7R	①	—	—	RRA7R	⑤	—	—	WRA14R	②	⑥	⑦
RA8R	②	—	—	RRA8R	②	—	—	WRA16R	②	⑥	⑦

When selecting options FL, NTBL or NTBR be sure to check the following conditions for stroke and side-mounted motor direction.

- ① Cannot be selected for 100mm or less
- ② Cannot be selected for 50mm
- ③ Cannot be selected for 110mm or less
- ④ Cannot be selected for 65mm
- ⑤ Cannot be selected for 70mm
- ⑥ Can only be selected when MR is selected
- ⑦ Can only be selected when ML is selected

- The flange rod attachment option cannot be used on side mounting position for RCS4-RRA8R when the following strokes are selected.

· RCS4-RRA8R: 50 to 100mm (standard/with brake)

## ■ Mounting Orientation

○: Can be installed △: Daily inspection required

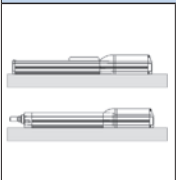
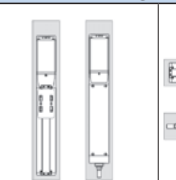
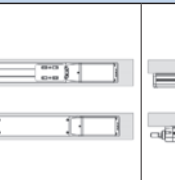
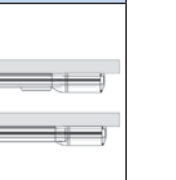
		Mounting orientation				
						
Classification	Series	Type	Horizontal mounting on flat surface	Vertical mounting (*1)	Side mounting	Ceiling mounting
Standard specification	RCS4	SA/WSA	○	○	△ (*2)	△ (*2)
		RA/RRA/WRA	○ (*3)	○	○	○
		TA	○	○	○	○
Cleanroom Specification	RCS4CR	SA/WSA	○	○	△ (*4)	△ (*4)

- \*1. When mounting vertically, please install the motor on the top if possible. While installing the motor on the bottom will not cause problems during normal operation, long periods of inactivity may cause the grease to separate, flow into the motor unit, and cause problems on rare occasions.
- \*2. While installation in the side and ceiling mount positions are available, this may cause slack or misalignment in the stainless steel sheet. Continuing to use it this way could cause the stainless steel sheet to break. Please inspect it daily and adjust the sheet if any slack or misalignment is found.
- \*3. Please install a support block when front mounting or back mounting a horizontally mounted actuator. Depending on the operation/installation conditions, vibration may cause damage to the actuator body. Do not fix the side-mounted motor specification only at the back of the reverse bracket. Fix the base with a support block, etc. If the actuator will experience external force or is being used in conjunction with a Cartesian robot, etc., please use the mounting holes on the base of the actuator to secure it into place.

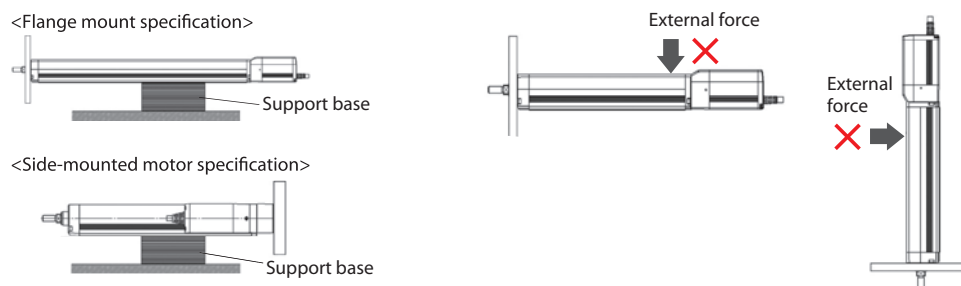

- \*4. ISO cleanliness class 2.5 may not be maintained in side mounting or ceiling mounting if slack or misalignment occurs in the stainless steel sheet. Please inspect it daily and adjust the sheet if any slack or misalignment is found.

# Tables of Payload by Acceleration

The tables below show the max. payload at each acceleration/deceleration for different models. Please select a model that satisfies the operational conditions you desire.

## RCS4 horizontal position

\* RCS4CR is the same.

Series	Type	Motor wattage	Lead	Payload per Acceleration/Deceleration (kg)						
				0.2G	0.3G	0.5G	0.7G	1.0G	1.2G	
RCS4	SA4C	60	2.5		20	20	20			
			5		17	17	15	15		
			10		14	14	12	10	6	
			16		10	8	6	6	4	
	SA6C	100	3		45	30	20			
			6		45	30	20	20		
			12		30	24	20	15	15	
			20		18	15	10	8	6	
	SA7C	200	30		11	6	6	4	4	3
			4		50	50	40			
			8		45	40	40	35		
			16		40	30	15	15	12	
	SA8C	400	24		30	12	10	6	5	5
			36		7	7	6	4	3	
			5		90	90	70			
			10		80	80	70	60		
	SA4R	60	20		60	40	30	20	20	15
			30		30	25	20	15	10	10
			48		8	8	6	5	4	4
			2.5		20	20	20			
	SA6R	100	5		17	17	15	13		
			10		14	14	12	10		
			16		10	8	6	6		
			3		45	30	20			
	SA7R	200	6		45	30	20	20		
			12		30	24	20	15		
			20		18	15	10	8		
			30		11	6	6	4		
	SA8R	400	4		50	50	40			
			8		45	40	40	35		
			16		38	30	15	15		
			24		30	12	10	6		
	RA4C	60	36		7	7	6	4		
			5		90	90	70			
			10		80	80	70	60		
			20		60	40	30	20		
	RA6C	100	30		30	25	20	15		
			48		8	8	6	5		
			2.5		40	40	35			
			5		30	30	25	20		
	RA7C	200	10		18	15	12	12	8	
			16		8	8	6	5	4	
			3		60	50	40			
			6		50	45	30	25		
	RA8C	400	12		25	20	20	12	12	
			20		15	10	8	6	4	
			4		80	70	60			
			8		60	50	40	40		
	RA4R	60	16		45	30	25	20	20	15
			24		20	15	10	10	10	8
5			100	100	80	60				
10				80	80	70	60			
RA6R	100	20		60	40	25	20	20	15	
		2.5		40	40	35				
		5		30	30	25	20			
		10		18	15	12	12			
RA7R	200	16		8	8	6	5			
		3		60	50	40				
		6		50	45	30	25			
		12		25	20	20	12	12		
RA8R	400	20		15	10	8	6			
		4		80	70	60				
		8		60	50	40	40			
		16		45	30	25	20			

RCS4 horizontal position

\* RCS4CR is the same.

Series	Type	Motor wattage	Lead	Payload per Acceleration/Deceleration (kg)						
				0.2G	0.3G	0.5G	0.7G	1.0G	1.2G	
RCS4	RRA4C	60	2.5		40	40	35			
			5		30	30	25	20		
			10		18	15	12	12	8	
			16		8	8	6	5	4	
	RRA6C	100	3		60	50	40			
			6		50	45	30	25		
			12		25	20	20	12	12	
			20		15	10	8	6	4	
	RRA7C	200	4		80	70	60			
			8		60	50	40	40		
			16		45	30	25	20	15	
			24		20	15	10	10	8	
	RRA8C	400	5	100	100	80	60			
			10		80	80	70	60		
			20		60	40	25	20	15	
			30		30	20	15	10	8	
	RRA4R	60	2.5		40	40	35			
			5		30	30	25	20		
			10		18	15	12	12		
			16		8	8	6	5		
	RRA6R	100	3		60	50	40			
			6		50	45	30	25		
			12		25	20	20	12		
			20		15	10	8	6		
	RRA7R	200	4		80	70	60			
			8		60	50	40	40		
			16		45	30	25	20		
			24		20	15	10	10		
	RRA8R	400	5	100	100	80	60			
			10		80	80	70	60		
			20		60	40	25	20		
			30		30	20	15	10		
	WRA10C	60	2.5		40	35	25			
			5		25	20	15	10		
			10		16	16	12	10	8	
			16		5	5	4	3	2	
	WRA12C	100	3		60	50	40			
			6		40	40	30	25		
			12		25	25	20	15	15	
			20		12	10	8	6	4	
	WRA14C	200	4		85	70	60			
			8		65	50	40	40		
			16		50	30	25	20	15	
			24		25	15	10	6	4	
	WRA16C	400	5		100	80	60			
			10		80	80	70	60		
			20		60	40	25	20	15	
			30		30	20	15	8	6	
	WRA10R	60	2.5		40	35	25			
			5		25	20	15	10		
			10		13	13	9	6		
			16		5	5	4	3		
WRA12R	100	3		60	50	40				
		6		40	40	30	25			
		12		25	25	20	15			
		20		12	10	8	6			
WRA14R	200	4		85	70	60				
		8		65	50	40	40			
		16		50	30	25	20			
		24		25	15	10	6			
WRA16R	400	5		100	80	60				
		10		80	80	70	60			
		20		60	40	25	20			
		30		30	20	15	8			
WSA10C	50	2.5		40	30	18				
		5		27	27	20	18			
		10		16	16	12	12	6		
		16		7	7	5	4	3		

Foreword  
Slider Type  
Wide Slider Type  
Rod Type  
Radial Cylinder  
Wide Radial Cylinder  
Table Type  
Cleanroom Slider  
Cleanroom Wide Slider  
Options  
Reference Data  
Controller

# Tables of Payload by Acceleration

## RCS4 horizontal position

\* RCS4CR is the same.

Series	Type	Motor wattage	Lead	Payload per Acceleration/Deceleration (kg)					
				0.2G	0.3G	0.5G	0.7G	1.0G	1.2G
RCS4	WSA12C	100	3		55	30	15		
			6		45	40	30	20	
			12		25	25	20	15	15
			20		15	10	8	6	4
			30		5	5	5	4	3
	WSA14C	200	4		80	60	30		
			8		65	50	40	40	
			16		45	30	20	20	18
			24		20	15	15	10	5
			36		7	6	6	4	3
	WSA16C	400	5		100	100	80		
			10		80	80	70	60	
			20		60	40	25	22	20
			30		30	25	20	10	8
	WSA10R	60	2.5		40	30	18		
			5		27	27	20	18	
			10		16	16	12	12	
			16		7	7	5	4	
	WSA12R	100	3		55	30	15		
			6		43	40	30	20	
			12		23	23	16	15	
			20		13	10	8	6	
			30		5	5	5	4	
	WSA14R	200	4		75	60	30		
			8		65	50	40	40	
			16		45	30	20	20	
			24		20	15	15	10	
			36		7	6	6	4	
	WSA16R	400	5		100	100	80		
			10		80	80	70	60	
			20		60	40	25	22	
			30		30	25	20	10	
	TA4C (Single Guide)	60	2.5		5	5	5		
			5		5	5	5	5	
			10		5	5	5	5	5
			16		4	4	4	4	3
			2.5		10	10	10		
	TA4C (Double Guide)	60	5		10	10	10	8	
			10		8	8	8	6	4
			3		10	10	10		
			6		8	8	8	8	8
	TA6C (Single Guide)	100	12		8	8	8	8	8
			20		8	8	8	6	4
			3		20	20	20		
			6		20	20	20	20	
			12		14	14	14	14	12
	TA6C (Double Guide)	100	4		15	15	15		
			8		15	15	15	15	
			16		15	15	15	15	15
			24		12	12	12	10	8
4				30	30	30			
TA7C (Single Guide)	200	8		30	30	25	25		
		16		25	25	20	20	15	
		2.5		5	5	5			
		5		5	5	5	5		
		10		5	5	5	5		
TA7C (Double Guide)	200	16		4	4	4	4		
		2.5		10	10	10			
		5		10	10	10	8		
		10		8	8	8	6		
		3		10	10	10			
TA6R (Single Guide)	100	3		10	10	8			
		6		8	8	8	8		
		12		8	8	8	8		
		20		8	8	8	6		
		3		20	20	20			
TA6R (Double Guide)	100	6		20	20	20	20		
		12		14	14	14	14		
		4		15	15	15			
		8		15	15	15	15		
		16		15	15	15	15		
TA7R (Single Guide)	200	24		12	12	12	10		
		4		30	30	30			
		8		30	30	25	25		
		16		25	25	20	20		
		2.5		5	5	5			

RCS4 vertical position

\* RCS4CR is the same.

Series	Type	Motor wattage	Lead	Payload per Acceleration/Deceleration (kg)						
				0.2G	0.3G	0.5G	0.7G	1.0G	1.2G	
RCS4	SA4C	60	2.5		12	12	10			
			5		8	8	6	6		
			10		5	5	3	3	2	
			16		3	3	1.5	1.5	1	
	SA6C	100	3		15	14	10			
			6		15	15	15	15		
			12		11	10	10	8	8	
			20		6	5	4	4	2	
	SA7C	200	30		3.5	2	2	1.5	1.5	
			4		25	25	20			
			8		20	20	20	18		
			16		12	12	10	8	8	
	SA8C	400	24		7	7	6	5	4	
			36		4	4	3	2	2	
			5		45	45	35			
			10		35	35	35	30		
	SA4R	60	20		20	20	18	15	12	
			30		12	12	10	8	6	
			2.5		12	12	10			
			5		8	8	6	6		
	SA6R	100	10		4.5	4.5	3	3		
			16		2.5	2.5	1.5	1.5		
			3		15	14	10			
			6		15	15	15	15		
	SA7R	200	12		9	9	9	8		
			20		5	5	4	4		
			30		3	2	2	1.5		
			4		25	25	20			
	SA8R	400	8		18	18	18	16		
			16		12	12	10	8		
			24		6	6	5	5		
			36		4	4	3	2		
	RA4C	60	5		45	45	35			
			10		35	35	35	30		
			20		20	20	18	15		
			30		12	12	10	8		
	RA6C	100	2.5		10	10	10			
			5		6	6	6	6		
			10		4	4	4	4	3	
			16		2	2	2	2	2	1
	RA7C	200	3		20	20	20			
			6		20	15	12	12		
			12		10	8	8	6	6	
			20		4	4	3	3	2	
	RA8C	400	4		35	35	30			
			8		25	25	20	20		
			16		12	12	10	8	8	
			24		6	6	6	4	4	
RRA4C	60	5	72	55	40	25				
		10		40	30	30	20			
		20		20	20	15	12	12		
		2.5		10	10	10				
RA4R	60	5		6	6	6	6			
		10		4	4	4	4			
		16		2	2	2	2			
		3		20	20	20				
RA6R	100	6		19	15	12	12			
		12		9	8	8	6			
		20		4	4	3	3			
		4		35	35	30				
RA7R	200	8		25	25	20	20			
		16		12	12	10	8			
		24		6	6	6	4			
		5	72	55	40	25				
RA8R	400	10		40	30	30	20			
		20		20	20	15	12			
		2.5		10	10	10				
		5		6	6	6	6			
RRA4C	60	10		4	4	4	4	3		
		16		2	2	2	2	2	1	

Foreword  
Slider Type  
Wide Slider Type  
Rod Type  
Radial Cylinder  
Wide Radial Cylinder  
Table Type  
Cleanroom Slider  
Cleanroom Wide Slider  
Options  
Reference Data  
Controller

# Tables of Payload by Acceleration

RCS4 vertical position

\* RCS4CR is the same.

Series	Type	Motor wattage	Lead	Payload per Acceleration/Deceleration (kg)						
				0.2G	0.3G	0.5G	0.7G	1.0G	1.2G	
RCS4	RRA6C	100	3		20	20	20			
			6		20	15	12	12		
			12		10	8	8	6	6	
			20		4	4	3	3	2	
	RRA7C	200	4		35	35	30			
			8		25	25	20	20		
			16		12	12	10	8	8	
			24		6	6	6	4	4	
	RRA8C	400	5	72	50	40	25			
			10		40	30	30	20		
			20		20	20	15	12	12	
			30		8	8	8	6	6	
	RRA4R	60	2.5		10	10	10			
			5		6	6	6	6		
			10		4	4	4	4		
			16		2	2	2	2		
	RRA6R	100	3		20	20	20			
			6		19	15	12	12		
			12		9	8	8	6	6	
			20		4	4	3	3		
	RRA7R	200	4		35	35	30			
			8		25	25	20	20		
			16		12	12	10	8	8	
			24		6	6	6	4	4	
	RRA8R	400	5	72	50	40	25			
			10		34	30	30	20		
			20		17	17	15	12	12	
			30		8	8	8	6	6	
	WRA10C	60	2.5		10	8	8			
			5		5	5	5	5		
			10		3	3	2	2	1	
	WRA12C	100	3		20	20	20			
			6		15	15	12	12		
			12		6	6	6	5	5	
			20		2	2	1.5	1.5	1	
	WRA14C	200	4		30	30	30			
			8		20	20	20	20		
			16		8	6	6	6	5	
			24		3	3	2	2	2	
	WRA16C	400	5		50	30	25			
			10		35	35	35	20		
			20		12	12	10	10	8	
			30		6	5	4	3	1.5	
	WRA10R	60	2.5		10	8	8			
5				5	5	5	5			
10				2.5	2.5	2	2			
WRA12R	100	3		20	20	20				
		6		15	15	12	12			
		12		6	6	6	5			
		20		2	2	1.5	1.5			
WRA14R	200	4		30	30	30				
		8		20	20	20	20			
		16		8	6	6	6			
		24		3	3	2	2			
WRA16R	400	5		50	30	25				
		10		35	35	35	20			
		20		12	12	10	10			
		30		6	5	4	3			
WSA10C	60	2.5		10	10	6				
		5		5	5	5	5			
		10		3	3	3	3	2		
WSA12C	100	3		15	10	6				
		6		15	15	12	10			
		12		8	8	8	6	6		
		20		3	3	2	2	2		



RCS4 vertical position

\* RCS4CR is the same.

Series	Type	Motor wattage	Lead	Payload per Acceleration/Deceleration (kg)					
				0.2G	0.3G	0.5G	0.7G	1.0G	1.2G
RCS4	WSA14C	200	4		25	20	12		
			8		10	10	10	10	
			16		8	8	8	8	8
			24		2.5	2.5	2.5	2.5	2.5
	WSA16C	400	5		50	45	30		
			10		35	35	35	30	
			20		20	15	15	12	10
			30		12	12	8	8	6
	WSA10R	60	2.5		10	10	6		
			5		5	5	5	5	
			10		3	3	3	3	
	WSA12R	100	3		15	10	6		
			6		15	15	12	10	
			12		8	8	8	6	
			20		3	3	2	2	
	WSA14R	200	4		25	20	12		
			8		10	10	10	10	
			16		8	8	8	8	
			24		2.5	2.5	2.5	2.5	
	WSA16R	400	5		50	45	30		
			10		35	35	35	30	
			20		18	15	15	12	
			30		12	12	8	8	
	TA4C (Single Guide)	60	2.5		9	9	9		
			5		6	6	6	6	
			10		3	3	3	3	3
			16		1.5	1.5	1.5	1.5	1.5
	TA4C (Double Guide)	60	2.5		9	9	9		
			5		6	6	6	6	
			10		3	3	3	3	3
			16		1.5	1.5	1.5	1.5	1.5
	TA6C (Single Guide)	100	3		12	12	12		
			6		10	10	10	10	
			12		6	6	6	6	6
			20		4	4	3	3	2
	TA6C (Double Guide)	100	3		12	12	12		
			6		10	10	10	10	
			12		6	6	6	6	6
			20		4	4	3	3	2
	TA7C (Single Guide)	200	4		20	20	20		
			8		18	18	18	18	
			16		10	10	8	8	6
24				5	5	4	4	3	
TA7C (Double Guide)	200	4		24	24	24			
		8		18	18	18	18		
		16		8	8	8	8	6	
		24		5	5	4	4	3	
TA4R (Single Guide)	60	2.5		9	9	9			
		5		6	6	6	6		
		10		3	3	3	3		
		16		1.5	1.5	1.5	1.5		
TA4R (Double Guide)	60	2.5		9	9	9			
		5		6	6	6	6		
		10		3	3	3	3		
		16		1.5	1.5	1.5	1.5		
TA6R (Single Guide)	100	3		10	10	8			
		6		10	10	8	8		
		12		6	6	6	6		
		20		4	4	3	3		
TA6R (Double Guide)	100	3		12	12	12			
		6		10	10	10	10		
		12		6	6	6	6		
		20		4	4	3	3		
TA7R (Single Guide)	200	4		20	20	20			
		8		18	18	18	18		
		16		10	10	8	8		
		24		5	5	4	4		
TA7R (Double Guide)	200	4		24	24	24			
		8		18	18	18	18		
		16		8	8	8	8		
		24		5	5	4	4		

Foreword

Slider Type

Wide Slider Type

Rod Type

Radial Cylinder

Wide Radial Cylinder

Table Type

Cleanroom Slider

Cleanroom Wide Slider

Options

Reference Data

Controller

# Selection Guideline for Allowable Load Mass

The radial cylinder has a built-in guide, so loads up to a certain level can be applied to the rod without using an external guide.

Refer to the graphs below for the allowable load mass.

If the allowable load will be exceeded under the required operating conditions, add an external guide.

## ■ Allowable Load Mass for Horizontally Mounted RCS4-RR Series

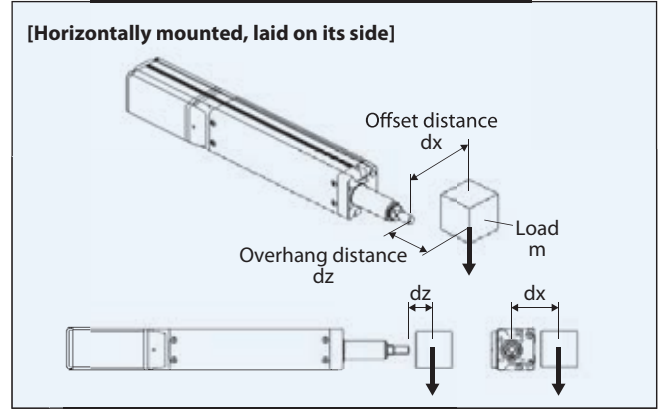
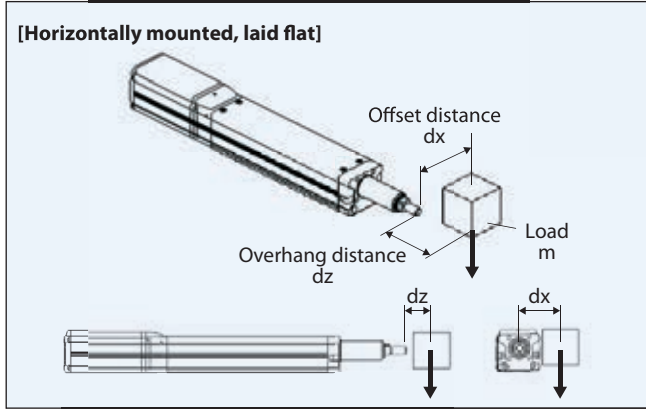

### ■ RCS4-RR4 / RCS4-RR6 / RCS4-RR7 / RCS4-RR8

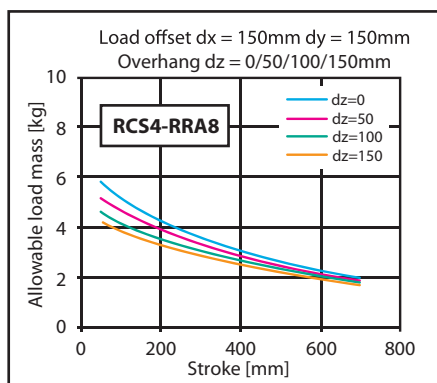
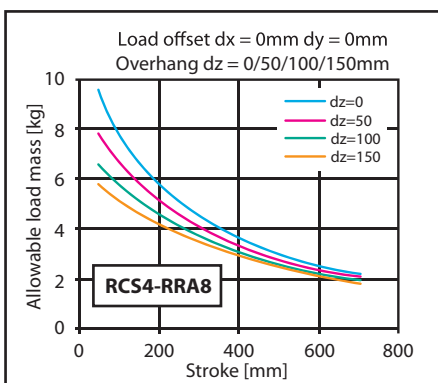
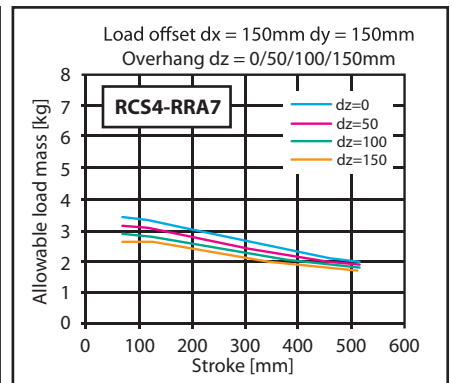
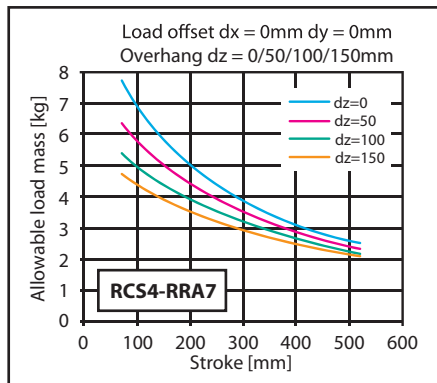
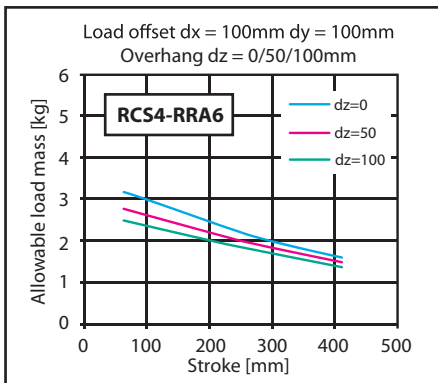
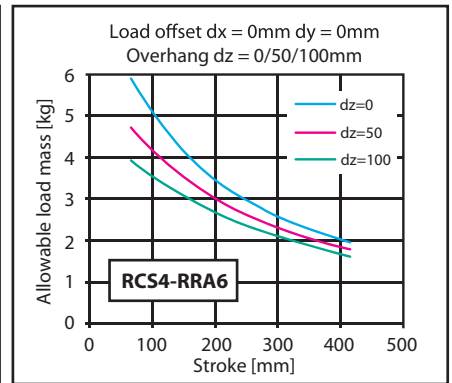
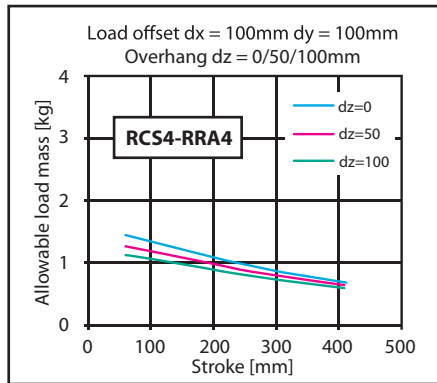
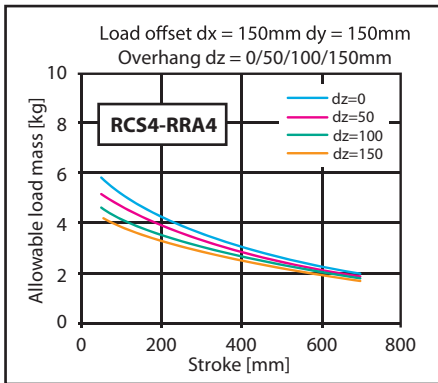

■ Allowable Load Mass for Vertically Mounted RCS4-RRA Series

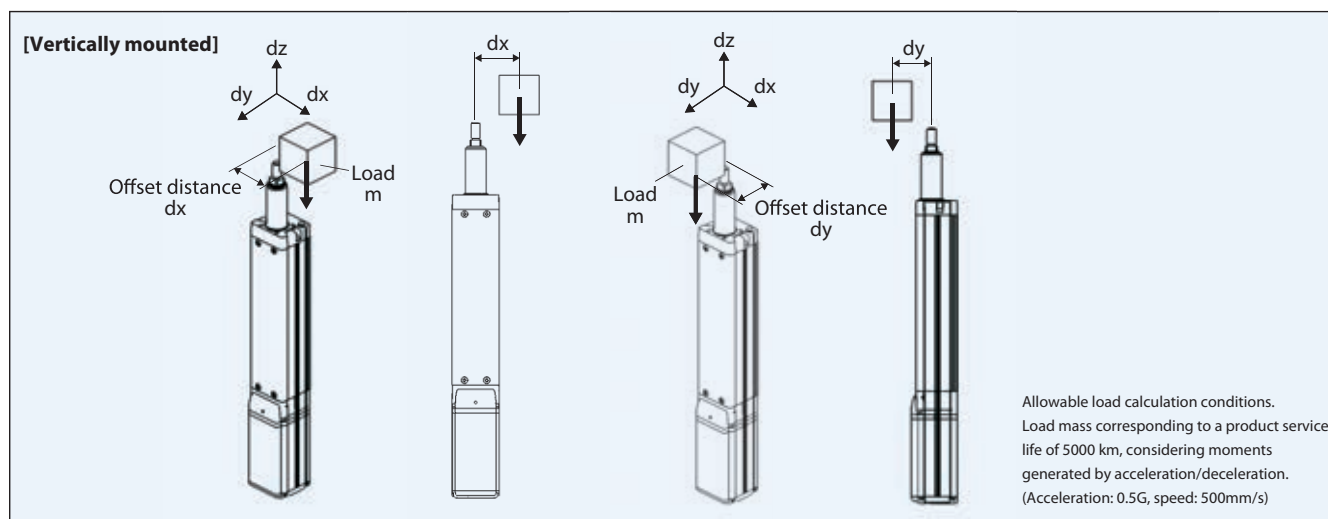

■ RCS4-RRA4

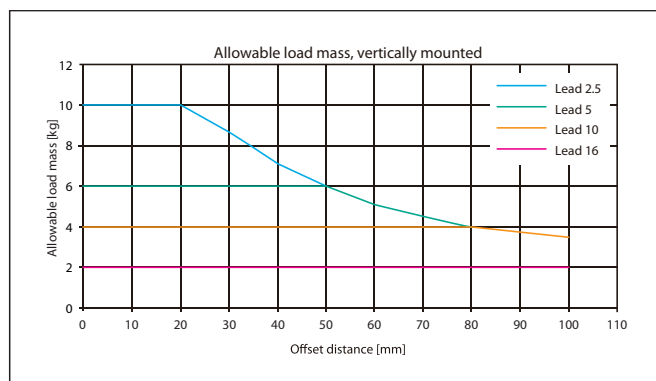

■ RCS4-RRA6

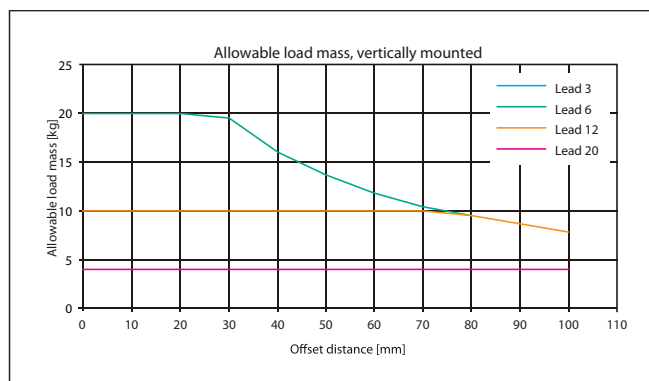

■ RCS4-RRA7

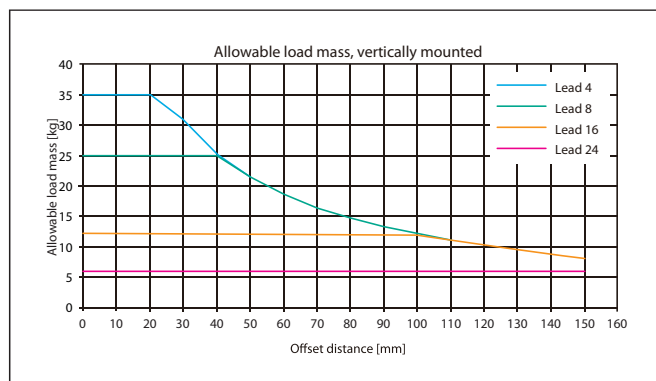

■ RCS4-RRA8

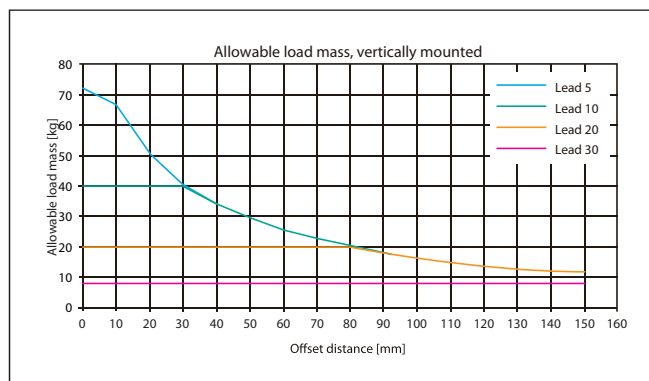

# Selection Guideline for Allowable Load Mass

## ■ Allowable Load Mass for Horizontally Mounted RCS4-WRA Series

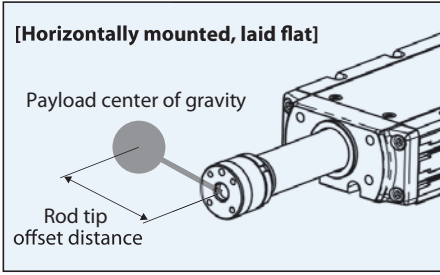

Offset distance dx:  
100mm or less

Overhang distance dz:  
0mm/  
50mm/  
75mm/  
100mm/  
150mm

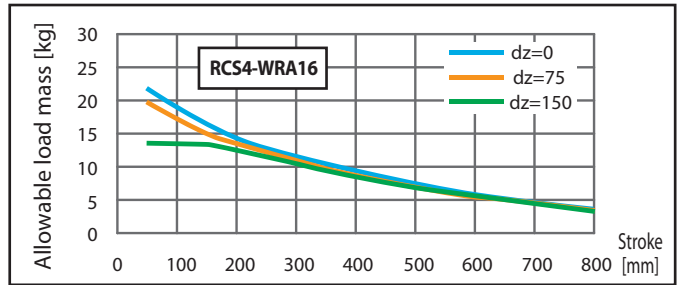
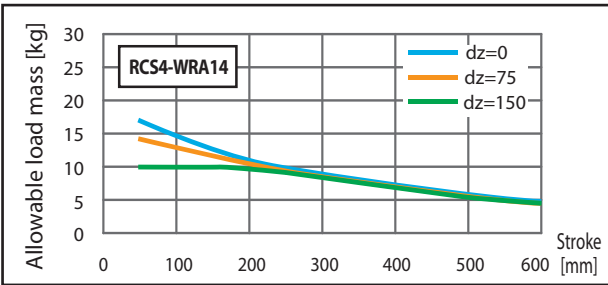
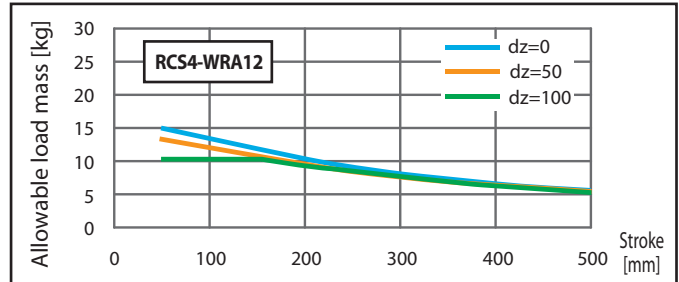
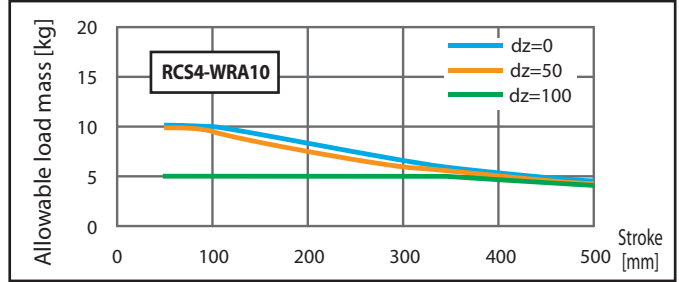
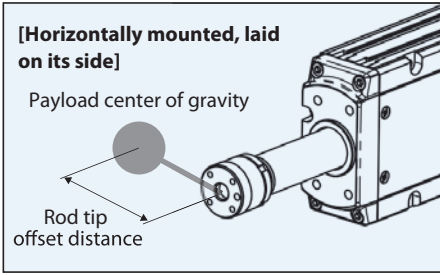

## ■ Allowable Load Mass for Vertically Mounted RCS4-WRA Series

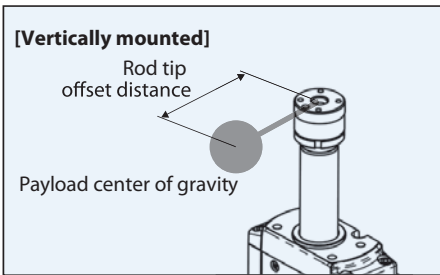

Offset distance dx:  
100mm or less

Overhang distance dz:  
0mm/  
50mm/  
75mm/  
100mm/  
150mm

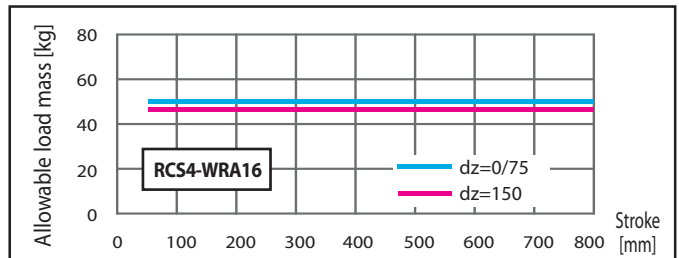
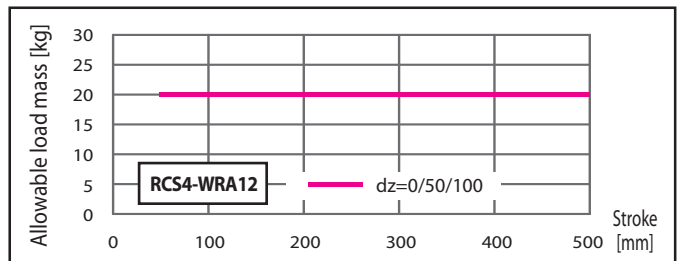
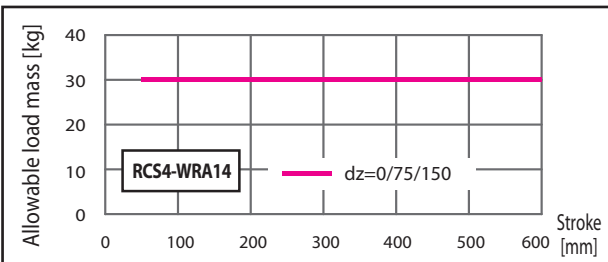
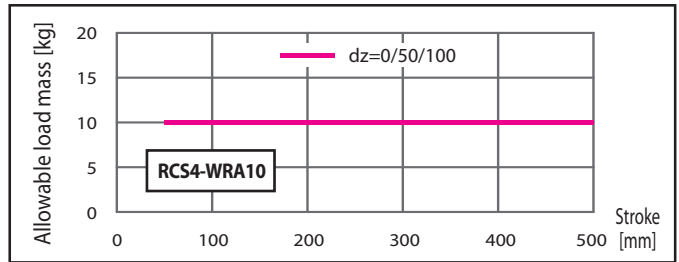

### ■ Allowable Load Mass for Horizontally Mounted RCS4-TA Series (Table Type)

Due to the table type structure, longer stroke actuators result in lower allowable load mass.

■ RCS4-TA4 (horizontal)

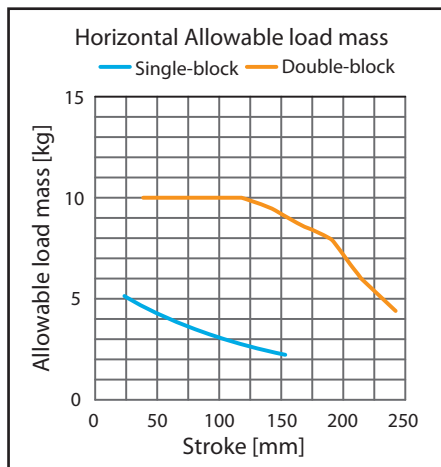

■ RCS4-TA4 (side)

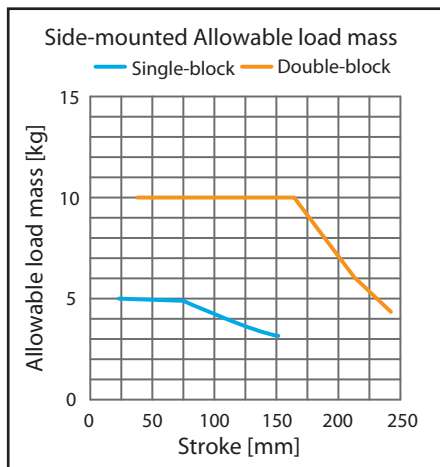

■ RCS4-TA6 (horizontal)

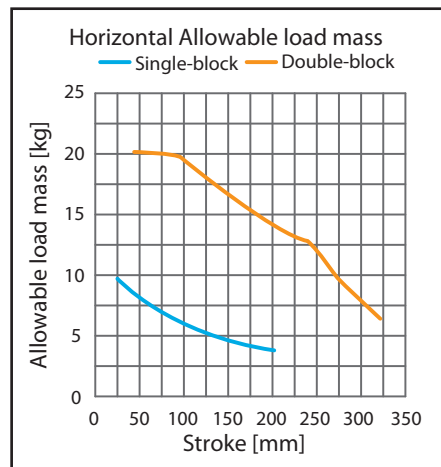

■ RCS4-TA6 (side)

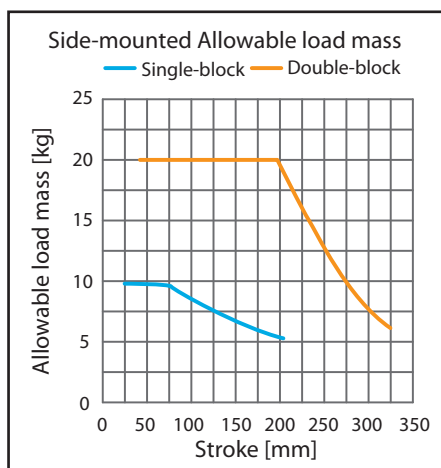

■ RCS4-TA7 (horizontal)

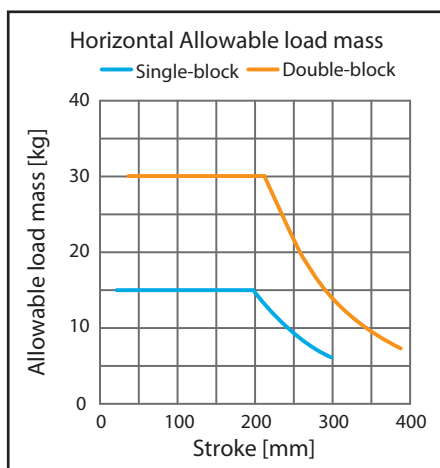

■ RCS4-TA7 (side)

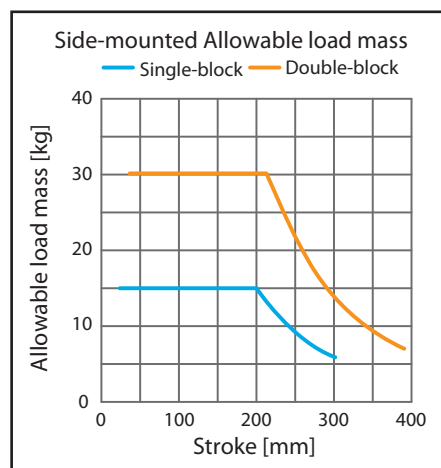

### ■ Allowable Load Mass for Vertically Mounted RCS4-TA Series (Table Type)

Due to the table type structure, longer stroke actuators result in lower allowable load mass.

■ RCS4-TA4

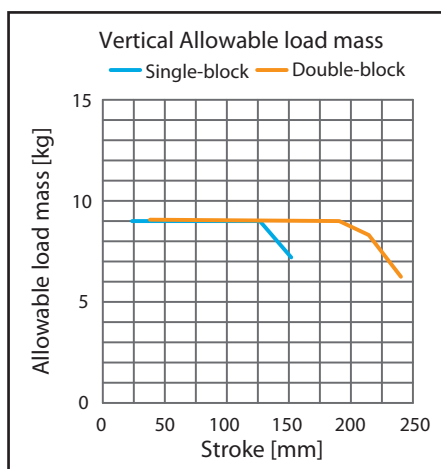

■ RCS4-TA6

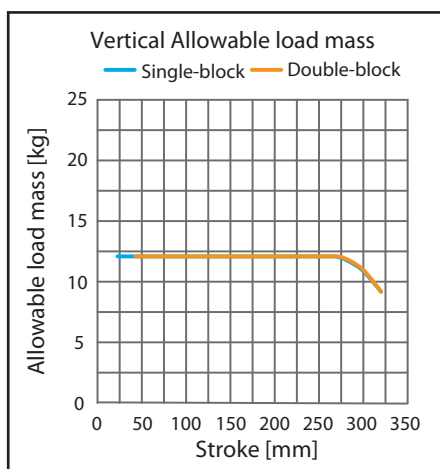

■ RCS4-TA7

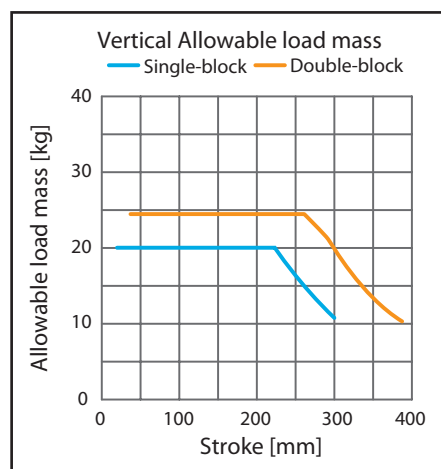

# Duty

Duty cycle varies depending on the operation conditions (payload, acceleration/deceleration, etc.).

Calculate the load factor LF and acceleration/deceleration time ratio  $t_{od}$  from the following formula and obtain it from the graph.

**1 Calculate the load factor LF from the following formula.**

RCS4 can be used at or above the rated acceleration/deceleration.

The formula will differ depending on the command acceleration/deceleration.

(1) When the command acceleration/deceleration is at or below the rated acceleration/deceleration, use formula (A).

The load factor LF formula differs depending on the model. Check the target model and calculate the load factor.

$$\text{(A) Load factor: LF } \textcircled{1} = \frac{M \times \alpha}{M_1 \times \alpha_1} (\%)$$

- Payload at rated acceleration :  $M_1$
- Rated acceleration/deceleration :  $\alpha_1$
- Actual payload :  $M (M \leq M_1)$
- Command acceleration/deceleration :  $\alpha (\alpha \leq \alpha_1)$

(Note) Please refer to the model number/spec table of each model for payload and rated acceleration/deceleration at rated acceleration/deceleration.

(2) When the command acceleration/deceleration is higher than the rated acceleration/deceleration, use formula (B).

$$\text{(B) Load factor: LF } \textcircled{2} = \frac{M \times \alpha}{M_2 \times \alpha} = \frac{M}{M_2} (\%)$$

- Actual payload :  $M$
- Command acceleration/deceleration :  $\alpha$
- Payload of command acceleration/deceleration :  $M_2 (M \leq M_2)$

(Note) For the acceleration/deceleration of each model and the payload corresponding to that acceleration/deceleration, refer to the table of payload by acceleration for each model.

The load factor is as follows when operating under the following operating conditions.

As an example, we will use the table of payload by acceleration of "RCS4-SA8C, 400 W, Lead 30".

Model	Type	Motor wattage	Lead [mm]	Payload by Acceleration/Deceleration [kg]				
				0.3G	0.5G	0.7G	1G	1.2G
RCS3	SA8C	400W	30	30	25	20	15	10

(Note) When horizontally mounted, the rated acceleration/deceleration is 0.3G

**<Example 1>**

Actual payload : 12kg  
 Command acceleration/deceleration : 1.0G  
 Payload of command acceleration/deceleration : 15kg  
 Load factor: LF  $\textcircled{2}$  = 80%

**<Example 2>**

Actual payload : 12.5kg  
 Command acceleration/deceleration : 0.5G  
 Payload of command acceleration/deceleration : 25kg  
 Load factor: LF  $\textcircled{2}$  = 50%

**<Example 3>**

Actual payload : 30kg  
 Command acceleration/deceleration : 0.3G  
 Payload of command acceleration/deceleration : 30kg  
 Load factor: LF  $\textcircled{1}$  = 100%  
 (Note) Use load factor calculation method (A).

**2 Calculate the acceleration/deceleration time ratio  $t_{od}$  from the following formula.**

$$\text{Acceleration/deceleration time ratio: } t_{od} = \frac{\text{Acceleration time} + \text{deceleration time}}{\text{Operating time}} \%$$

$$\text{Acceleration time} = \frac{\text{Speed (mm/s)}}{\text{Acceleration (mm/s}^2\text{)}} \text{ (s)}$$

$$\text{Acceleration (mm/s}^2\text{)} = \text{Acceleration (G)} \times 9800\text{mm/s}^2$$

$$\text{Deceleration time} = \frac{\text{Speed (mm/s)}}{\text{Deceleration (mm/s}^2\text{)}} \text{ (s)}$$

$$\text{Deceleration (mm/s}^2\text{)} = \text{Deceleration (G)} \times 9800\text{mm/s}^2$$

**3 Read the duty guideline from calculated "load ratio" and "acceleration/deceleration time ratio".**

Duty guideline graph 1 (for standard use)

Example: When the load ratio is 80% and the acceleration/deceleration time ratio is 80%, the duty guideline will be approximately 75%.

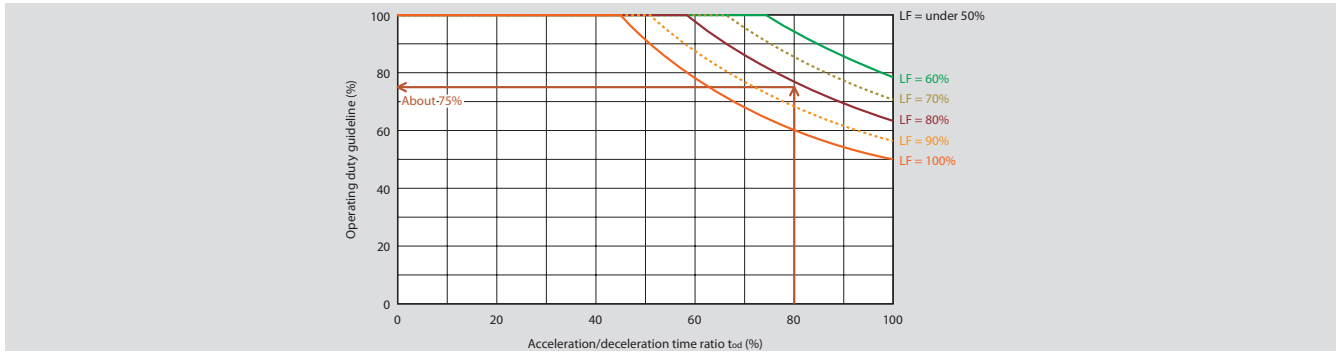

# RCS4(CR) Double Slider Specification

Series	Model	Lead (mm)	Allowable dynamic moment						Overhang load length (mm)	Cleanroom specification suction amount (Nℓ/min)	(*) Payload compensation mass (kg)	Slider length (mm)	Minimum stroke for double slider (mm)	
			Standard rated service life (km)	Slider span (mm)		Ma direction (N-m)	Mb direction (N-m)	Mc direction (N-m)						Ma direction Mb/Mc direction
				Actual slider span	Slider cover span									
RCS4	SA4C(R)	16	5000	60	24	44.6	63.6	15.7	420	-	1	76	50	
		10												
		5												
		2.5												
	SA6C(R)	20	5000	90	40	106	152	40	630	-	2	110	50	
		12												
		6												
		3												
	SA7C(R)	24	5000	70	20	285	285	145	810	-	2	130	50	
		16												
		8												
		4												
SA8C(R)	30	5000	120	35	565	565	237	1200	-	2.5	165	50		
	20													
	10													
	5													
RCS4CR	SA4C	10	5000	60	24	44.6	63.6	15.7	420	60	1	76	50	
		5								30				
		2.5								20				
	SA6C	12	5000	90	40	106	152	40	630	110	2	110	50	
		6								60				
		3								35				
	SA7C	16	5000	70	20	285	285	145	810	100	2	130	50	
		8								50				
		4								40				
	SA8C	10	5000	120	35	565	565	237	1200	120	2.5	165	50	
		5								50				

(\*) Double slider specification values obtained by subtracting the payload compensation value from the standard specification payload are the payload specification values.  
 (Note) Double slider is not configured for leads not listed in the table.

- Foreword
- Slider Type
- Wide Slider Type
- Rod Type
- Radial Cylinder
- Wide Radial Cylinder
- Table Type
- Cleanroom Slider
- Cleanroom Wide Slider
- Options
- Reference Data
- Controller

Foreword  
Slider Type  
Wide Slider Type  
Rod Type  
Radial Cylinder®  
Wide Radial Cylinder  
Table Type  
Cleanroom Slider  
Cleanroom Wide Slider  
Options  
Reference Data  
Controller



Position controller for  
Single-axis robot / Cartesian robot / RoboCylinder RCS2/RCS3/RCS4

Features

1 Supports Battery-less Absolute Encoder

The RCS2, RCS3, RCS4, ISB and ISDB can operate equipped with a battery-less absolute encoder. As no battery is needed for retaining position data, it is possible to save control panel space, which helps to keep down the initial costs and maintenance costs.



2 Major field networks supported <Optional function>

Direct connection can be made to CompoNet, EtherCAT, EtherNet/IP and PROFINET IO in addition to DeviceNet, CC-Link and PROFIBUS-DP. Operation is also possible by specifying the coordinate values directly via the field network.



3 Equipped with vibration control function <Standard function>

The equipped vibration control function reduces the runout (vibration) of the workpiece attached to the slider of the actuator. The standby time for vibration convergence is shortened, reducing the cycle time.

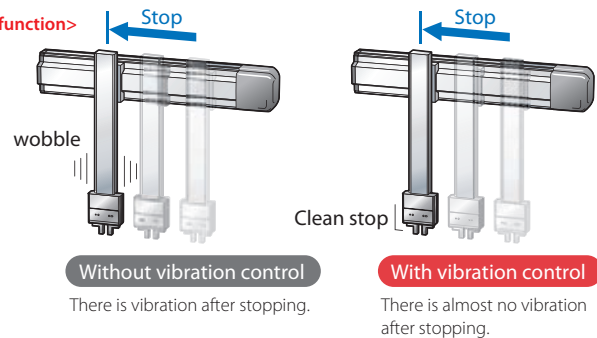

4 Capable of predictive maintenance <Standard function>

- A function that issues a warning when a motor overload is detected has been included. Monitoring changes in the temperature of the motor makes it possible to detect abnormalities before the occurrence of a breakdown or a malfunction.
- Improvement of monitoring functions. Similar to an oscilloscope, it is now possible to acquire the waveforms of the position, speed, etc. from the instant the state of the selected signal changes. Also, it is possible to acquire the signal states of positioning complete, alarms, etc.
- Smart tuning and off-board tuning enable acceleration/deceleration and gain adjustment according to the payload.
- A function that integrates the number of cycles with the traveled distance accumulation makes it possible to check maintenance timing.
- The calendar function makes it possible to keep a timetable of the alarms that have been generated.

<Maintenance information>

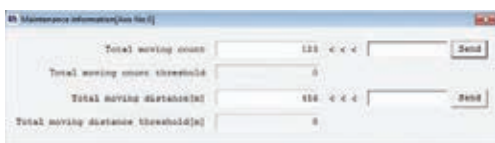

<Calendar function>

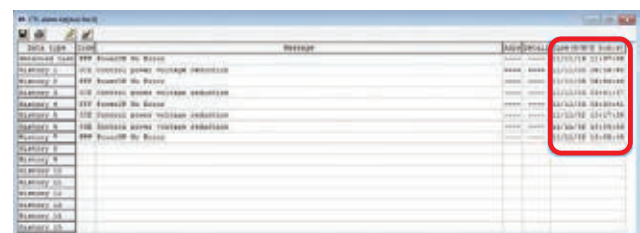



List of Models

Model Number		SCON-CB						
External view								
I/O type	Standard specification		Field network type (*1)					
	PIO connection specification (*1)	DeviceNet	CC-Link	PROFINET	CompoNet	EtherCAT	EtherNet/IP	PROFINET IO
DeviceNet connection specification		CC-Link connection specification	PROFIBUS-DP connection specification	CompoNet connection specification	EtherCAT connection specification	EtherNet/IP connection specification	PROFINET IO connection specification	
I/O type model number	NP/PN	DV	CC	PR	CN	EC	EP	PRT
Supported encoder	Battery-less Absolute Incremental	Absolute	Battery-less absolute/Incremental/Absolute					

(\*1) Please note that the network specifications cannot use PIO or pulse train communication.  
 (Reference) Please contact IAI for details of the PLC function equipped type.

Model

**SCON** - [ ] - [ ] - [ ] - [ ] - [ ] - [ ] - [ ]

Series      Type      Motor Type      Encoder Type      Option      I/O Type      I/O Cable Length      Input power

CB	High-function type	
CGB	Global high-function type (with safety category spec.)	

12	12W	150	150W
20	20W	200	200W
30D	30W	200S	200W
30R	30W	300S	300W
60	60W	400	400W
100	100W	600	600W
100S	100W	750	750W

(Example) 12: 12W servo motor supported

WAI	Battery-less Absolute Incremental
A	Absolute
AI	Index absolute type (*1)
AM	Absolute Multi-rotation type (*1)

(\*1) DD motor operation mode is added.

HA	Hi-accel./decel. specification
----	--------------------------------

\* High acceleration/deceleration specification is only available if the high acceleration/deceleration supported option is selected for the actuator.  
 <High Acceleration/Deceleration Target Actuators>  
 RCS2-SA4C/SA5C/SA6C/SA7C/RA4C/RA5C/RGS4C/RGS5C/RGD4C/RGD5C

NP	PIO NPN specification
PN	PIO PNP specification
DV	DeviceNet connection specification
CN	CompoNet connection specification
CC	CC-Link connection specification
PR	PROFIBUS-DP connection specification
EC	EtherCAT connection specification
EP	EtherNet/IP connection specification
PRT	PROFINET IO connection specification

0	No cable
2	2m (Standard)
3	3m
5	5m

\* Check the power supply voltage that can be selected in the actuator page.  
 \* When a field network specification is selected, the I/O cable length is "0" (No cable).

**Notes**

In principle, the same type of motor as the type of motor of the actuator to be connected should be entered, but there are some models where the motor type of some controllers and actuators do not match. Be sure to check the corresponding models listed below during selection.

<30D/30R/200S Target Actuators>

- Controller motor type [30D] 30W actuators other than RS
- Controller motor type [30R] RS
- Controller motor type [200S] DD-LT18□ DD-LT18□ DDA-LT18C DD-LT18□ DD-LT18C DDACR-LT18C

\* For 200S, the controller casing will be 400W. Check the 400W specification for the price.

Foreword  
Slider Type  
Wide Slider Type  
Rod Type  
Radial Cylinder  
Wide Radial Cylinder  
Table Type  
Cleanroom Slider  
Cleanroom Wide Slider  
Options  
Reference Data  
Controller

## System Configuration

### <SCON-CB/CGB>

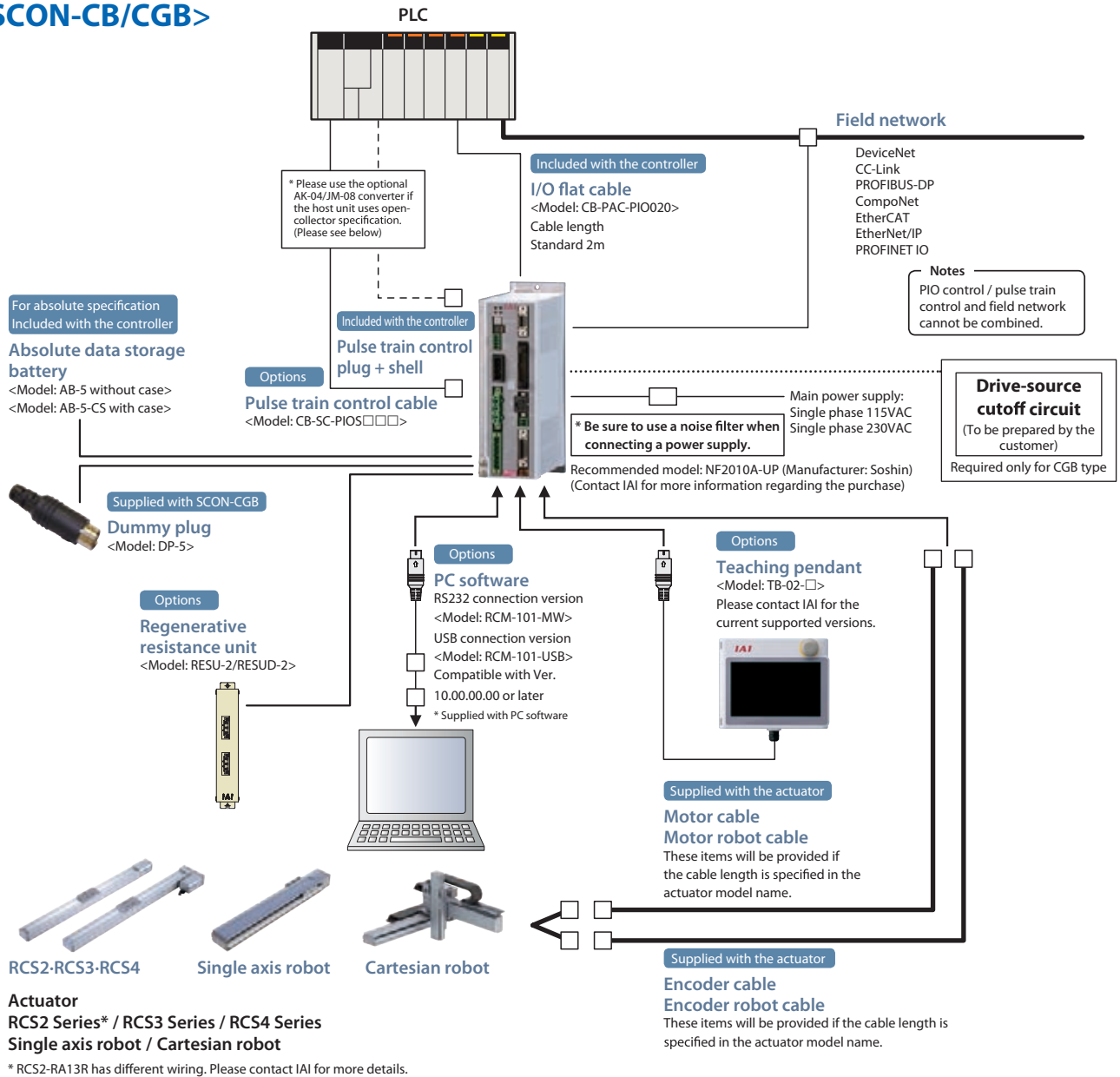

### ■ Pulse Converter: Model AK-04

Converts open-collector specification pulses to the differential system.

Please use this converter if the host controller uses open-collector specification for output pulse.

#### ■ Specifications

Item	Specification
Input power	24VDC ±10% (Max. 50mA)
Input pulse	Open collector (collector current max. 12mA)
Input frequency	200kHz or less
Output pulse	Differential output (Max. 10mA) (26C31 or equivalent)
Mass	10g or less (not including the cable connectors)
Accessories	37104-3122-000L (e-CON connector) x 2 by 3M Suitable power line AWG No.24~26

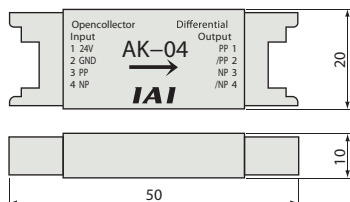

### ■ Pulse Converter: Model JM-08

Converts differential pulses to the open-collector specification. Please use this converter if the host controller uses open-collector specification for pulse input.

#### ■ Specifications

Item	Specification
Input power	24VDC ±10% (Max. 50mA)
Input pulse	Differential input (Max. 10mA) (RS422 compliant)
Input frequency	500kHz or less
Output pulse	24VDC open collector (collector current max. 25mA)
Mass	10g or less (not including the cable connectors)
Accessories	37104-3122-000FL (e-CON connector) x 2 by 3M Suitable power line AWG No.24~26

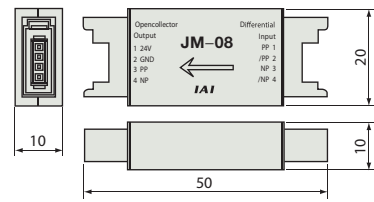

Operation mode

The control method of this controller can be selected from positioner mode and pulse train control mode. In positioner mode, it can be operated by specifying the position data (travel position, speed, acceleration, etc.) numbers input to the controller from the outside using I/O (input/output signal). As well, in positioner mode, 8 different operation modes can be selected depending on the parameters. In pulse train control mode, it is possible to control the travel distance, speed, acceleration and the like with pulses sent from an external pulse generator.

Mode		Type	Number of positioning points	Features
Positioner mode	Positioning mode	PIO pattern 0	64 points	This is the factory default standard mode. Specify from outside the position number you want to move.
	Teaching mode	PIO pattern 1	64 points	In this mode, the slider (rod) can be moved with an external signal to register the stop position as position data.
	256-point mode	PIO pattern 2	256 points	In this mode, the number of positioning points in positioning mode is increased to 256.
	512-point mode	PIO pattern 3	512 points	In this mode, the number of positioning points in positioning mode is increased to 512.
	Solenoid valve mode 1	PIO pattern 4	7 points	This mode allows travel by signal ON/OFF alone, as with air cylinder solenoid valves.
	Solenoid valve mode 2	PIO pattern 5	3 points	In solenoid valve mode, the output signal is the same as the air cylinder auto switch.
	Force control mode 1	PIO pattern 6	32 points	In this mode, position movement during force control can be done with positioning mode. (The maximum number of positioning points is 32)
	Force control mode 2	PIO pattern 7	5 points	In this mode, position movement during force control can be done with solenoid valve mode. (The maximum number of positioning points is 5)
Pulse train control mode	Pulse train control mode for incremental	PIO pattern 0	—	Position data input to the controller is not required, as operation is according to the transmitted pulses.
	Pulse train control mode for absolute	PIO pattern 1		

Table of I/O Signals \* I/O signal assignment can be selected from 9 types.

Pin No.	Category	Number of positioning points	Parameter (PIO pattern) selection								
			0	1	2	3	4	5	6	7	0/1
			Positioning mode 64 points	Teaching mode 64 points	256-point mode 256 points	512-point mode 512 points	Solenoid valve mode 1 7 points	Solenoid valve mode 2 3 points	Force control mode 1 32 points	Force control mode 2 5 points	Pulse train mode —
1A	24V		P24								
2A	24V		P24								
3A	—		NC								
4A	—		NC								
5A	Input	IN0	PC1	PC1	PC1	PC1	ST0	ST0	PC1	ST0	SON
6A		IN1	PC2	PC2	PC2	PC2	ST1	ST1(JOG+)	PC2	ST1	RES
7A		IN2	PC4	PC4	PC4	PC4	ST2	ST2(-)	PC4	ST2	HOME
8A		IN3	PC8	PC8	PC8	PC8	ST3	—	PC8	ST3	TL
9A		IN4	PC16	PC16	PC16	PC16	ST4	—	PC16	ST4	CSTP
10A		IN5	PC32	PC32	PC32	PC32	ST5	—	—	—	DCLR
11A		IN6	—	MODE	PC64	PC64	ST6	—	—	—	BKRL
12A		IN7	—	JISL	PC128	PC128	—	—	—	—	RMOD
13A		IN8	—	JOG+	—	PC256	—	—	CLBR	CLBR	RSTR (Note)
14A		IN9	BKRL	JOG-	BKRL	BKRL	BKRL	BKRL	BKRL	BKRL	—
15A		IN10	RMOD	RMOD	RMOD	RMOD	RMOD	RMOD	RMOD	RMOD	—
16A		IN11	HOME	HOME	HOME	HOME	HOME	—	HOME	HOME	—
17A		IN12	*STP	*STP	*STP	*STP	*STP	—	*STP	*STP	—
18A		IN13	CSTR	CSTR/PWRT	CSTR	CSTR	—	—	CSTR	—	—
19A		IN14	RES	RES	RES	RES	RES	RES	RES	RES	—
20A		IN15	SON	SON	SON	SON	SON	SON	SON	SON	—
1B		Output	OUT0	PM1	PM1	PM1	PM1	PE0	LSO	PM1	PE0
2B	OUT1		PM2	PM2	PM2	PM2	PE1	LS1(TRQS)	PM2	PE1	SV
3B	OUT2		PM4	PM4	PM4	PM4	PE2	LS2(-)	PM4	PE2	INP
4B	OUT3		PM8	PM8	PM8	PM8	PE3	—	PM8	PE3	HEND
5B	OUT4		PM16	PM16	PM16	PM16	PE4	—	PM16	PE4	TLR
6B	OUT5		PM32	PM32	PM32	PM32	PE5	—	TRQS	TRQS	*ALM
7B	OUT6		MOVE	MOVE	PM64	PM64	PE6	—	LOAD	LOAD	*EMGS
8B	OUT7		ZONE1	MODES	PM128	PM128	ZONE1	ZONE1	CEND	CEND	RMDS
9B	OUT8		PZONE/ZONE2	PZONE/ZONE1	PZONE/ZONE1	PM256	PZONE/ZONE2	PZONE/ZONE2	PZONE/ZONE1	PZONE/ZONE1	ALM1
10B	OUT9		RMDS	RMDS	RMDS	RMDS	RMDS	RMDS	RMDS	RMDS	ALM2
11B	OUT10		HEND	HEND	HEND	HEND	HEND	HEND	HEND	HEND	ALM4
12B	OUT11		PEND	PEND/WEND	PEND	PEND	PEND	—	PEND	PEND	ALM8
13B	OUT12		SV	SV	SV	SV	SV	SV	SV	SV	*OVLW/ *ALML
14B	OUT13		*EMGS	*EMGS	*EMGS	*EMGS	*EMGS	*EMGS	*EMGS	*EMGS	REND (Note)
15B	OUT14		*ALM	*ALM	*ALM	*ALM	*ALM	*ALM	*ALM	*ALM	ZONE1
16B	OUT15	*BALM	*BALM	*BALM	*BALM	*BALM	*BALM	*BALM	*BALM	ZONE2	
17B	—									—	
18B	—									—	
19B	0V						N			N	
20B	0V						N			N	

\* In the above table, signals in ( ) represent functions available before the home return.  
 \* In the above table, signals preceded by \* are negative logic signals. Negative logic input signals are processed when turned OFF.  
 Negative logic output signals normally remain ON while the power is supplied, and turn OFF when the signal is output.  
 (Note): It is available to use only in Pulse-Train Control Mode PIO Pattern 1.

Foreword  
 Slider Type  
 Wide Slider Type  
 Rod Type  
 Radial Cylinder  
 Wide Radial Cylinder  
 Table Type  
 Cleanroom Slider  
 Cleanroom Wide Slider  
 Options  
 Reference Data  
 Controller

## Field Network Specification: Explanation of Operation Modes

If the SCON-CB is controlled via a field network, you can select one of the following nine modes to operate the actuator. Please note that the data areas required on the PLC side will vary depending on the mode.

### Mode Description

	Mode	Description
0	Remote I/O mode	Similarly to the PIO specification, this mode operates by directing bytes to ON/OFF via a network. The number of positioning points and functions will vary depending on the operation patterns (PIO patterns) set by the controller's parameters.
1	Position/simple direct value mode	The target position value is directly input, while all other operational conditions (speed, acceleration, etc.) are set by indicating the position number corresponding to the desired operating conditions from the position data table.
2	Half direct value mode	The actuator is operated by directly inputting values for speed, acceleration/deceleration rate and push current, as well as the target position.
3	Full direct value mode	The actuator is operated by directly inputting values for the target position, speed, acceleration/deceleration rate and push current limit value, etc. In addition, you are able to read the current position, current speed, and the command current value, etc.
4	Remote I/O mode 2	This mode is the same as the remote I/O mode above, with the added functionality of reading current position and the command current value.
5	Position/simple direct value mode 2	This mode is equipped with a force control function instead of the teaching and zone functions of the position/simple direct value mode above.
6	Half direct value mode 2	Instead of the half direct value mode command current reading function, it can read load cell data. It also supports the force control function.
7	Remote I/O mode 3	This mode is the same as the remote I/O mode above, with the added functionality of reading current position and load cell data.
8	Half direct value mode 3	This mode supports the vibration control function instead of the jog function of the half direct value mode.

### Required Data Size for Each Network

	Mode	DeviceNet	CompoNet	CC-Link	PROFIBUS-DP	EtherCAT	EtherNet/IP	PROFINET IO
0	Remote I/O mode	2 bytes	2 bytes	1 station	2 bytes	2 bytes	2 bytes	2 bytes
1	Position/simple direct value mode	8 bytes	8 bytes	1 station	8 bytes	8 bytes	8 bytes	8 bytes
2	Half direct value mode	16 bytes	16 bytes	2 stations	16 bytes	16 bytes	16 bytes	16 bytes
3	Full direct value mode	32 bytes	32 bytes	4 stations	32 bytes	32 bytes	32 bytes	32 bytes
4	Remote I/O mode 2	12 bytes	12 bytes	1 station	12 bytes	12 bytes	12 bytes	12 bytes
5	Position/simple direct value mode 2	8 bytes	8 bytes	1 station	8 bytes	8 bytes	8 bytes	8 bytes
6	Half direct value mode 2	16 bytes	16 bytes	2 stations	16 bytes	16 bytes	16 bytes	16 bytes
7	Remote I/O mode 3	12 bytes	12 bytes	1 station	12 bytes	12 bytes	12 bytes	12 bytes
8	Half direct value mode 3	16 bytes	16 bytes	2 stations	16 bytes	16 bytes	16 bytes	16 bytes

### List of Functions by Operation Mode

	Remote I/O mode	Position/simple direct value mode	Half direct value mode	Full direct value mode (Note 1)	Remote I/O mode 2	Position/simple direct value mode 2	Half direct value mode 2	Remote I/O mode 3	Half direct value mode 3
Number of positioning points	512 points	768 points	Unlimited	Unlimited	512 points	768 points	Unlimited	512 points	Unlimited
Operates by direct assignment of position data	—	○	○	○	—	○	○	—	○
Direct assignment of speed/acceleration	—	—	○	○	—	—	○	—	○
Push-motion operation	○	○	○	○	○	○	○	○	○
Current position read	—	○	○	○	○	○	○	○	○
Current speed read	—	—	○	○	—	—	○	—	○
Operation by position number input	○	○	—	—	○	○	—	○	—
Completed position number read	○	○	—	—	○	○	—	○	—
Force control	△ (Note)	—	—	○	△ (Note)	○	○	△ (Note)	—
Vibration control	○	○	—	○	○	○	—	○	○
Servo gain switching	○	○	○	○	○	○	—	○	○

\* ○ indicates that the operation is supported, and — indicates that it is not supported.  
(Note) Usable when PIO pattern is set to 6 or 7.

I/O Wiring Diagrams

Positioning Mode / Teaching Mode / Solenoid Valve Mode

PIO connector (NPN specification)

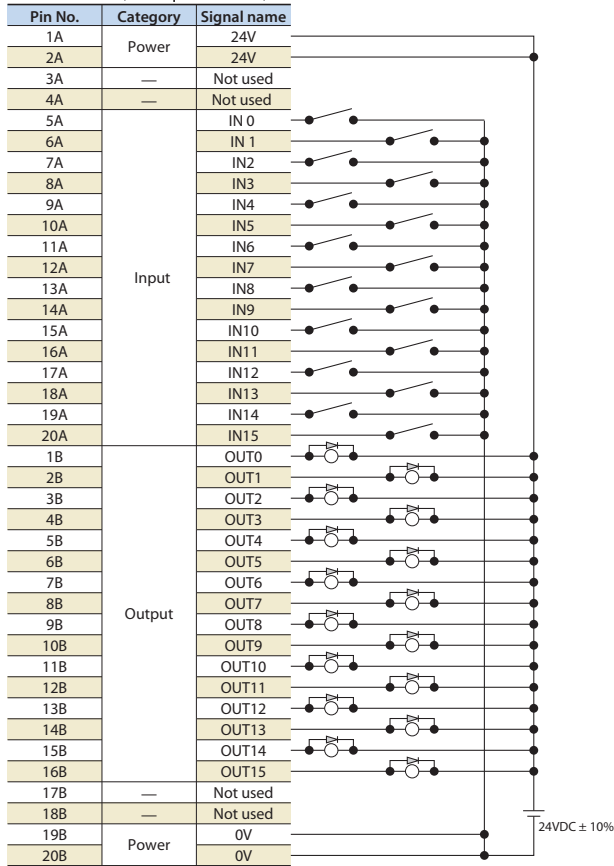

\* Connect pin numbers 1A and 2A to 24V, and connect pin numbers 19B and 20B to 0V.

Pulse Train Mode (Differential output)

Pulse connector

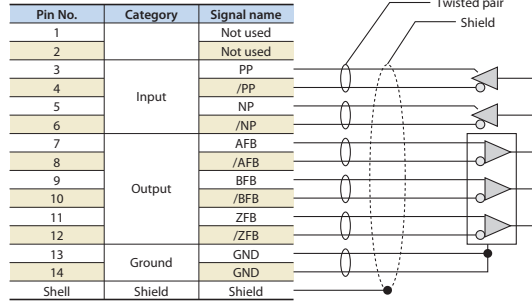

PIO connector (NPN specification)

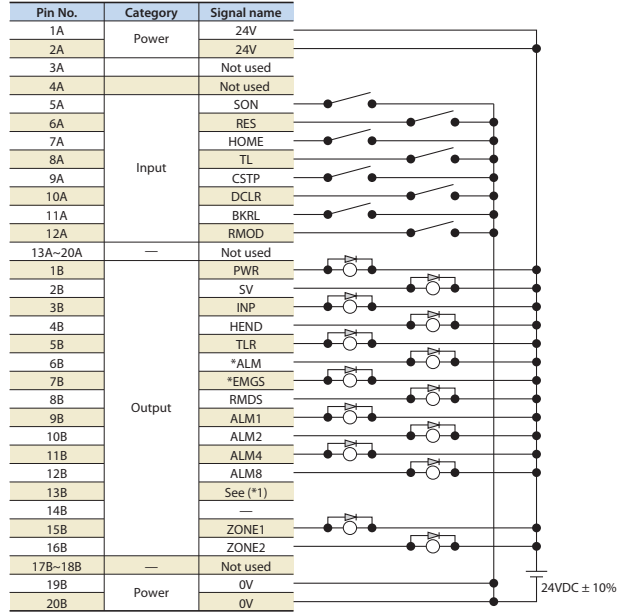

\* The shield of the twisted pair cable connected to the pulse connector must be connected to the shell. Also, set the cable length within 10m.

\* Connect pin numbers 1A and 2A to 24V, and connect pin numbers 19B and 20B to 0V. (\*1) -/\*ALML/\*OVLW/\*BALM (can be switched by parameter)

PIO Input/Output Interface

Input External input specification

Item	Specification
Input voltage	24VDC ±10%
Input current	4mA/circuit
ON/OFF voltage	ON voltage: Min. 18.0VDC OFF voltage Max. 6.0VDC
Isolation method	Photocoupler

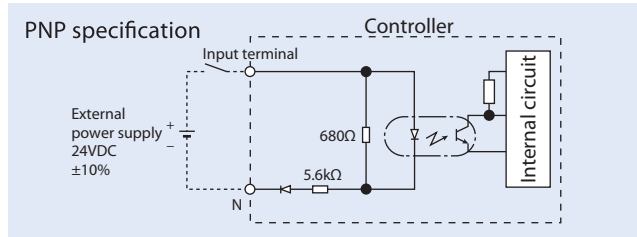
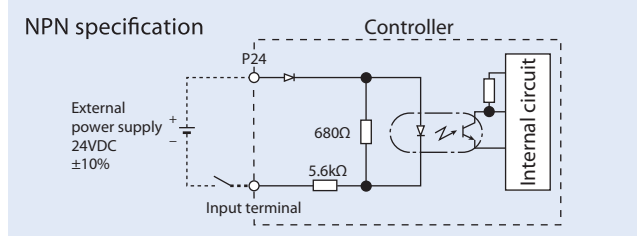

Output External output specification

Item	Specification
Load voltage	24VDC
Maximum load current	50mA/point
Leakage current	Max. 0.1mA/point
Isolation method	Photocoupler

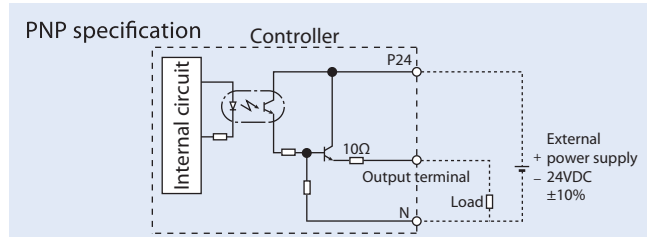
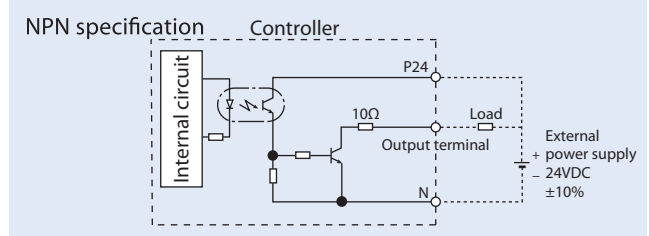

## Pulse Train Type Input/Output Specification (differential line driver specification)

### Input part

**Maximum input pulse** : Line driver interface 2.5Mpps  
**Isolation method** : Photocoupler isolation

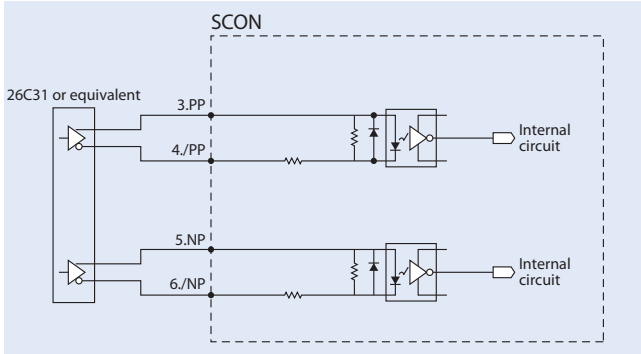

### Output part

**Maximum output pulse** : Line driver interface 2.5Mpps  
**Isolated/Non-isolated** : Non-isolated

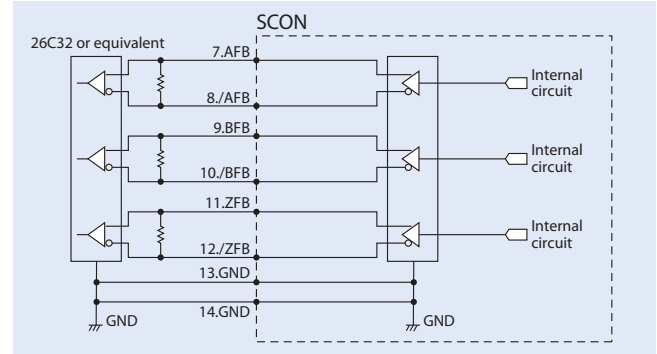

## Pulse Train Type Input/Output Specification (open collector specification)

The AK-04 (optional) is needed to input pulses. The JM-08 (optional) is required for pulse train output.

**Maximum input pulse** : 200kpps (AK-04 required)  
**Maximum output pulse** : 500kpps (JM-08 required)

- \* The 24VDC power supply connected to the AK-04 should be common with the PIO interface power supply.
- \* Make sure that the cable between the pulse output unit (PLC) and AK-04/JM-08 is as short as possible. **Also, make sure that the cable length between AK-04/JM-08 and the pulse connector is within 2m.**

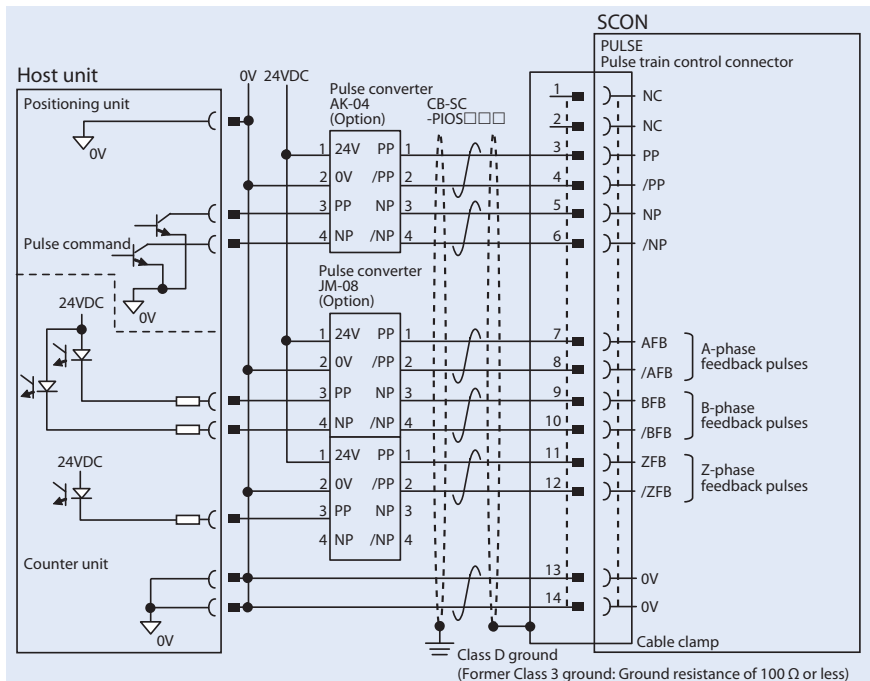

### Notes

Use the same power supply for open collector input/output to/from the host and for the AK-04 and JM-08.

## Command Pulse Input Patterns

Command pulse train pattern		Input terminal	Forward	Reverse	
Negative logic	Forward pulse train	PP-/PP			
	Reverse pulse train	NP-/NP			
	A forward pulse train indicates the amount of motor rotation in the forward direction, while a reverse pulse train indicates the amount of motor rotation in the reverse direction.				
	Pulse train	PP-/PP			
	Sign	NP-/NP	Low	High	
The command pulses indicate the amount of motor rotation, while the sign indicates the rotating direction.					
Positive logic	Phase A/B pulse train	PP-/PP			
	Phase A/B pulse train	NP-/NP			
	Command phases A and B pulse having a 90° phase difference (multiplier is 4) indicate the amount of motor rotation and the rotating direction.				
	Forward pulse train	PP-/PP			
	Reverse pulse train	NP-/NP	High	Low	

Specifications Table

Item	Specification	
Compatible motor capacity	Less than 400W	400W or more
Number of controlled axes	1-axis	
Method of operation	Positioner type/Pulse train type	
Number of positioning points	512 points (PIO specification), 768 points (fieldbus specification)	
Backup memory	Non-volatile memory (FRAM)	
I/O connector	40-pin connector	
Number of I/O points	Input 16 points / output 16 points	
I/O power supply	External supply 24VDC ±10%	
Serial communication	RS485 1ch	
Command pulse train input method (Note 1)	Differential line driver output supported	
Maximum input pulse frequency	Differential line driver system: Max. 2.5Mpps / Open collector system (pulse converter used): Max. 200kpps	
Position detection method	Incremental encoder / absolute encoder / serial encoder quasi absolute / battery-less absolute encoder	
Drive-source cutoff function	CB: available (relay built in) CGB: not available	
Electromagnetic brake forced release	External brake release switch ON/OFF	
Input power	Single phase 100~115VAC ±10% Single phase 200~230VAC ±10%	Single phase 200~230VAC ±10%
Power supply capacity	12W / 89VA 20W / 74VA 30W (Excluding RS)/94VA 30W (For RS)/186VA 60W (Excluding RCS3-CTZ5C)/186VA 60W (For RCS3-CTZ5C)/245VA 100W / 282VA	150W / 376VA 200W / 469VA 400W (Excluding RCS3-CT8C)/968VA 400W (For RCS3-CT8C)/1278VA 600W / 1212VA 750W / 1569VA
Vibration resistant	X, Y, and Z directions 10~57Hz Single-side width 0.035mm (continuous), 0.075mm (intermittent) 58~150Hz 4.9m/s <sup>2</sup> (continuous), 9.8m/s <sup>2</sup> (intermittent)	
Calendar/clock functionality	Retention time	Approx. 10 days
	Charging time	Approx. 100 hours
Protection functionality	Overcurrent, abnormal temperature, fan speed degradation monitoring, encoder disconnection, etc.	
Ambient operating temperature	0 to 40°C	
Ambient operating humidity	85% or less (Non-condensing)	
Operating ambience	Free from corrosive gases	
Ingress protection	IP20	
Mass	Approx. 900g (25g added for simple absolute specification)	Approx. 1.2kg (25g added for simple absolute specification)
External dimensions	58mm(W)×194mm(H)×121mm(D)	72mm(W)×194mm(H)×121mm(D)

(Note 1) Use a differential line driver method resistant to noise for the command pulse input method.  
If the open collector method must be used, convert the pulse to differential using the optional pulse converter (AK-04/JM-08).

\* The number of encoder pulses of actuators that can be operated with SCON-CB is 3072 pulses for RCS2-SRA7BD/SRGS7BD/SRGD7BD, 1600 pulses for RCS2-□□5N (incremental), 1048576 pulses for DD-□18P: 20 bits, 131072 pulses for DD-□18S: 17 bits, 2400 pulses for NS-S□M□ (incremental), 131072 pulse for ISB (battery-less absolute) and 16384 pulses for all other models.

Foreword  
Slider Type  
Wide Slider Type  
Rod Type  
Radial Cylinder  
Wide Radial Cylinder  
Table Type  
Cleanroom Slider  
Cleanroom Wide Slider  
Options  
Reference Data  
Controller

## External Dimensions

### Less than 400W

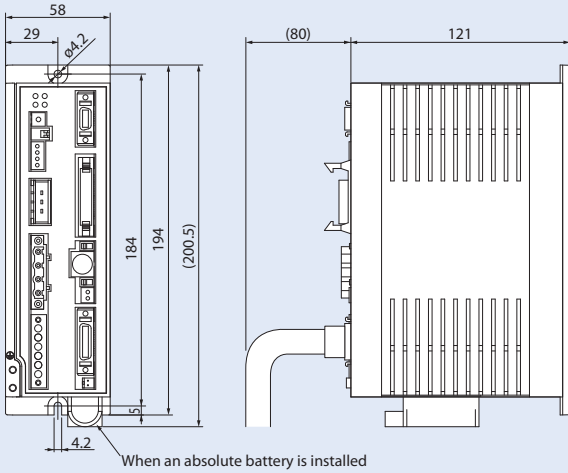

### 400W or more

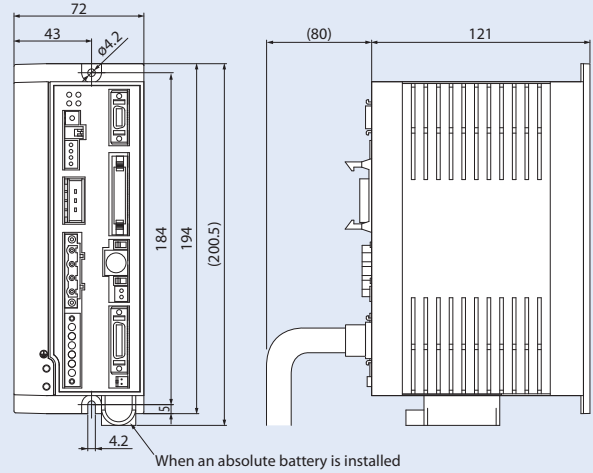

## Name of Each Component

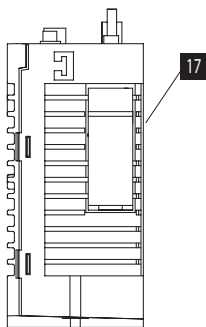
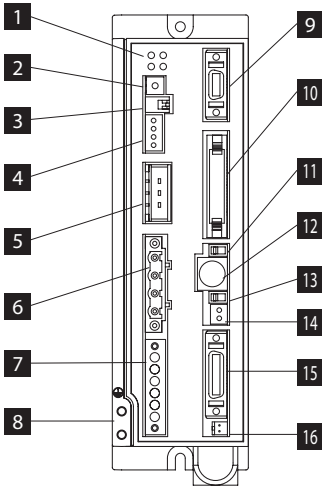

### 1 LED display

It represents the state of the controller.

Name	Color	Description
PWR	Green	Lights up on system-ready (after the power is turned on, in normal CPU)
SV	Green	Lights up on servo-on
ALM	Orange	Lights up on alarm
EMG	Red	Lights up on emergency stop

### 2 Rotary switch

Used to set up the controller address after connecting the controller in order to identify every controller connected.

### 3 Piano switch

Switch for the controller system.

Name	Description
1	Press-operation mode selection switch OFF: Positioner mode, ON: Pulse train control mode * Enabled at power on.
2	Used by the manufacturer for adjustment. Always keep this switch OFF.

### 4 System I/O connector

Connector for emergency stop switch, etc.

### 5 Regenerative resistance unit cable connector

Resistance unit connector for absorbing regenerative current that occurs when the actuator decelerates to a stop.

### 6 Motor connector

Connector for motor cable of actuator.

### 7 Power supply connector

Connector for the AC power supply. It has divided inputs on the control power supply side and motor power supply side.

### 8 Ground terminal

Screw for protective grounding. Be sure to ground.

### 9 Pulse train control connector

Connector used when operating in pulse train control mode. Feedback pulses are also enabled in positioner mode.

### 10 PIO connector

Cable connector for performing parallel communication with peripheral devices such as PLC.

### 11 Operation mode selection switch

Name	Description
MANU	Does not accept commands from PIO.
AUTO	Ready to accept commands from PIO.

\* The emergency stop switch on the teaching pendant is enabled when the connection is made, regardless of the states, AUTO or MANU. Be sure to turn OFF the power when disconnecting the teaching pendant and SIO communication cable.

### 12 SIO connector

Connector for teaching pendant or PC communication cable.

### 13 Brake release switch

Used to forcibly release the electromagnetic brake installed in the actuator.

\* To release the brake, the power supply (24VDC) for driving brake must be connected.

### 14 Brake power supply connector

Brake power 24VDC supply connector (required only when a brake-equipped actuator is connected).

### 15 Encoder/sensor connector

Connector for encoder/sensor cable.

### 16 Connector for the absolute data backup battery

Absolute data backup battery connector (required only for the absolute encoder specifications).

### 17 Absolute battery holder

Battery holder for installing the absolute data backup battery.



Options

Touch panel teaching pendant

■ **Features** A teaching device equipped with functions such as position teaching, trial operation, and monitoring.

■ **Model** **TB-02-C**

■ **Configuration**

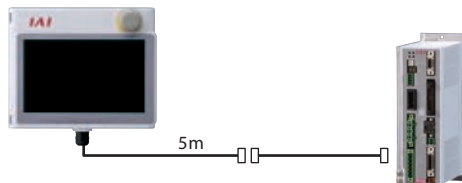

■ **Specifications**

Rated voltage	24V DC
Power consumption	3.6W or less (150mA or less)
Ambient operating temperature	0 to 40°C
Ambient operating humidity	20~85% RH (Non-condensing)
Environmental resistance	IP20
Mass	470g (TB-02 unit only)

PC software (Windows only)

■ **Features** The start-up support software which comes equipped with functions such as position teaching, trial operation, and monitoring. A complete range of functions needed for making adjustments contributes to shortened start-up time.

■ **Model** **RCM-101-MW** (with an external device communication cable + RS232 conversion unit)

■ **Configuration**

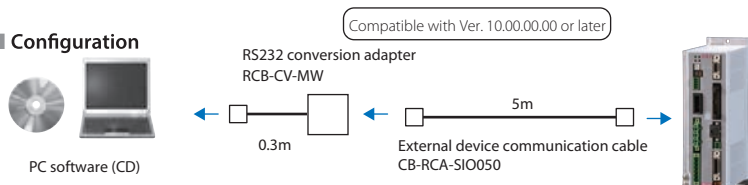

XP SP2 or later / Vista / 7 / 8 / 10



■ **Model** **RCM-101-USB** (with an external device communication cable + USB conversion adapter + USB cable)

■ **Configuration**

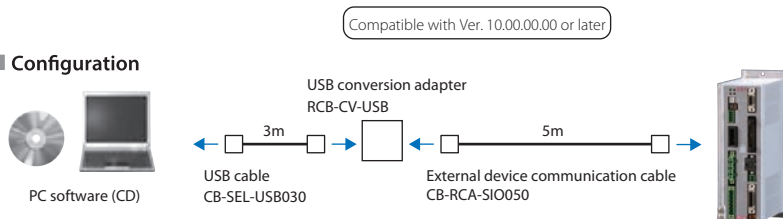

Regenerative resistance unit

■ **Features** Unit that converts the regenerative current generated in motor deceleration to heat. Check the total W of the actuator to be operated in the table below, and prepare one if regenerative resistance is required.

■ **Model** **RESU-2** (standard specification)/**RESUD-2** (DIN rail mounting specification)

■ **Specifications**

Model	RESU-2	RESUD-2
Unit weight	About 0.4kg	
Built-in regenerative resistance value	235Ω 80W	
Unit mounting method	Screw mount	DIN rail mount
Attached cable	CB-SC-REU010	

■ **Necessary Amount Guideline**

	Horizontal	Vertical
0	~100W	~100W
1	~400W	~400W
2	~750W	~750W

\* Depending on the operating conditions, a regeneration resistance higher than that mentioned above may be necessary.

■ **Necessary Amount Guideline (RCS2-RA13R)**

	Lead 2.5	Lead 1.25
Horizontal	1	0
Vertical	1	1

\* Depending on the operating conditions, a regeneration resistance higher than that mentioned above may be necessary.

■ **Necessary Amount Guideline (DD)**

Series	Type	Required number
DD	LT18□	1
DDA	LH18□	2

\* If two regenerative units are required, please prepare RESU-2 and RESU-1 (Consult IAI for more information).

■ **External Dimensions**

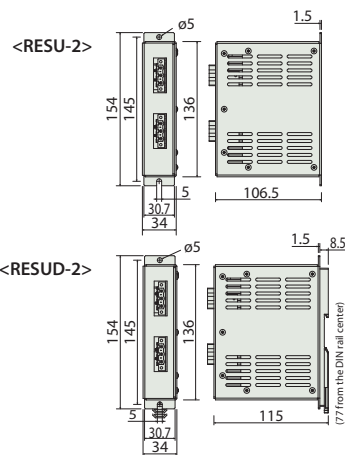

Absolute data storage battery

■ **Features** Absolute data storage battery for operating an actuator of the absolute specification.

■ **Model** **AB-5 (battery)**  
**AB-5-CS (with case)**



Dummy plug

■ **Features** This is required when the global controller type with safety category specification (SCON-CGB) is used.

■ **Model** **DP-5**



Foreword  
Slider Type  
Wide Slider Type  
Rod Type  
Radial Cylinder  
Wide Radial Cylinder  
Table Type  
Cleanroom Slider  
Cleanroom Wide Slider  
Options  
Reference Data  
Controller

## Maintenance Parts

When placing an order for a replacement cable, please use the model name shown below.

### ■ Cable Compatibility Chart

Model name		Motor cable	Motor robot cable	Encoder cable	Encoder robot cable	
①	RCS2(CR/W) RCS3(CR)	Models other than ② ~ ④	CB-RCC-MA□□□□	CB-RCC-MA□□□□-RB  CB-XEU-MA□□□□ (EU version)	CB-RCS2-PA□□□□	CB-X3-PA□□□□ CB-XEU3-PA□□□□ (EU version)
	RCS3				CTZ5C CT8C	-
②	RCS4(CR)					
③	RCS2**	RT	CB-RCC-MA□□□□	CB-RCC-MA□□□□-RB CB-XEU-MA□□□□ (EU vers.)	CB-RCS2-PLA□□□□	CB-X2-PLA□□□□ CB-XEU2-PLA□□□□ (EU vers.)
		RA13R (Standard)			CB-RCS2-PLA□□□□	CB-X2-PLA□□□□ CB-XEU2-PLA□□□□ (EU vers.)
		RA13R (With brake)	CB-RCC-MA□□□□	CB-RCC-MA□□□□-RB  CB-XEU-MA□□□□ (EU version)	CB-RCS2-PLA□□□□ * CB-RCS2-PLA□□□□ between the controller and brake	CB-X2-PLA□□□□ CB-XEU2-PLA□□□□ (EU vers.) * CB-X2-PLA□□□□ CB-XEU2-PLA□□□□ (EU vers.) between the controller and brake
④	NS	Without LS	-	CB-X-MA□□□□ CB-XEU-MA□□□□ (EU version)	-	CB-X3-PA□□□□ CB-XEU3-PA□□□□ (EU vers.)
		With LS	-	-	-	CB-X2-PLA□□□□ CB-XEU2-PLA□□□□ (EU vers.)
⑤	-	-	-	-	-	
⑥	DD/DDA DDCR/DDACR	LT18□	-	CB-X-MA□□□□ CB-XEU-MA□□□□ (EU vers.)	-	CB-X3-PA□□□□ CB-XEU3-PA□□□□ (EU version)
		LH18□	-	CB-XMC-MA□□□□ CB-XEUMC-MA□□□□ (EU vers.)	-	
⑦	DDA DDACR	LT18	-	CB-X-MA□□□□ CB-XEU-MA□□□□ (EU vers.)	-	CB-X3-PA□□□□ CB-XEU3-PA□□□□ (EU vers.)
		LH18	-	CB-XMC-MA□□□□ CB-XEUMC-MA□□□□ (EU vers.)	-	CB-DDB-BK□□□□ between brake box and actuator
⑧	(With brake)					
⑨	IS(P)WA	S/M/L	-	CB-XEU-MA□□□□	-	CB-X1-PA□□□□-WC
⑩	Models other than ① ~ ⑫		-	CB-X-MA□□□□  CB-XEU-MA□□□□ (EU version)	-	CB-X1-PA□□□□ CB-XEU1-PA□□□□ (EU vers.) (for 20m or less) *
					-	CB-X1-PA□□□□-AWG24 CB-XEU1-PA□□□□-AWG24 (EU vers.) (for 21m or more)
⑪	Models other than ① ~ ⑫	LS specification	-		-	CB-X1-PLA□□□□ CB-XEU1-PLA□□□□ (EU vers.) (for 20m or less) *
					-	CB-X1-PLA□□□□-AWG24 CB-XEU1-PLA□□□□-AWG24 (EU vers.) (for 21m or more)

\* Those that do not have the battery-less absolute specification will also be CB-X(EU)1-PA□□□□/CB-X(EU)1-PLA□□□□ for 20m or more.

\*\* For the RCS2-RA13R load cell specification cables, please contact IAI.

Model name	PIO flat cable	Pulse train control cable
⑬	SCON-CB	CB-PAC-PIO□□□□
⑭		CB-SC-PIOS□□□□

Model number	CB-RCC-MA □□□	Motor cable	for
	CB-RCC-MA □□□-RB	Motor robot cable	RCS2 / RCS3 / RCS4
	CB-X-MA □□□	Motor robot cable	for models other than RCS2 / RCS3 / RCS4 / DD(A)-H/LH18
	CB-XEU-MA □□□	EU motor robot cable	for RCS2 / RCS3 / RCS4 and other models

\* Enter the cable length (L) into □□□. Compatible to a Maximum of 30 meters.  
Ex.: 080 = 8m

(Note) Model number of (EU) motor robot cable with 1.25sq wire for DD(A)-H/LH18: CB-X(EU)MC-MA□□□.

(Fig.: Motor cable CB-RCC-MA□□□ / CB-RCC-MA□□□-RB / CB-X-MA□□□ with plastic connector)

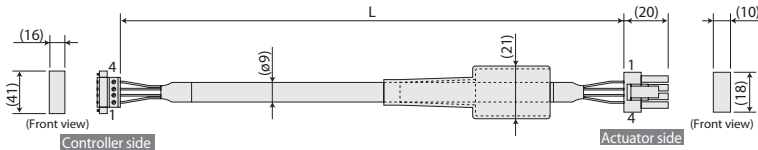

Minimum bending R:  $r = 51$  mm or more (for movable use)  
\* If the cable must be guided in a cable track, use a robot cable.

Wire	Color	Signal	No.	No.	Signal	Color	Wire
0.75sq	Green	PE	1	1	U	Red	0.75sq (crimped)
	Red	U	2	2	V	White	
	White	V	3	3	W	Black	
	Black	W	4	4	PE	Green	

(Fig.: EU motor robot cable CB-XEU-MA□□□, EU version with M18 plastic round connector)

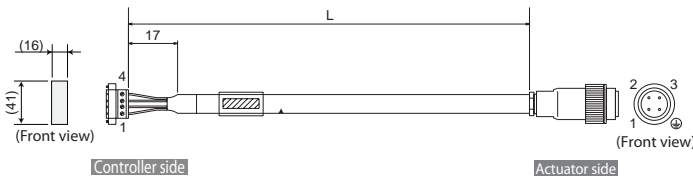

Minimum bending R:  $r = 51$  mm or more (for movable use)  
\* Only robot cable is available for this model

Wire	Color	Signal	No.	No.	Signal	Color	Wire
0.75sq	Green/yellow	PE	1	⊕	PE	Green/yellow	0.75sq (crimped)
	Black/white <sup>1"</sup>	U	2	1	U	Black/white <sup>1"</sup>	
	Black/white <sup>2"</sup>	V	3	2	V	Black/white <sup>2"</sup>	
	Black/white <sup>3"</sup>	W	4	3	W	Black/white <sup>3"</sup>	

Model number	CB-RCS2-PA □□□	Encoder cable	for RCS2 / RCS3
	CB-X3-PA □□□	Encoder robot cable	for NS / RCS2 / RCS3
	CB-XEU3-PA □□□	EU encoder robot cable	

\* Enter the cable length (L) into □□□. Compatible to a Maximum of 30 meters.  
Ex.: 080 = 8m

(Fig.: Encoder cable CB-RCS2-PA□□□ / CB-X3-PA□□□ with plastic connector)

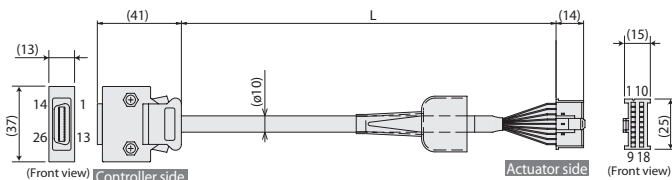

Minimum bending R:  $r = 58$  mm or more (for movable use)  
\* If the cable must be guided in a cable track, use a robot cable.

Wire	Color	Signal	No.	No.	Signal	Color	Wire
-	-	-	10	11	A	White/blue	White/blue
-	-	E24V	12	2	A	White/yellow	White/yellow
-	-	OV	13	3	B	White/red	White/red
White/green	LS	26	4	4	B	White/black	White/black
White/orange	LS	26	5	5	Z	White/purple	White/purple
-	CREEP	25	6	6	Z	White/gray	White/gray
-	OT	24	7	7	LS+	White/orange	White/orange
-	RSV	23	8	8	-	-	-
-	-	9	9	9	FG	(Ground)	(Ground)
-	-	18	10	10	SD	Orange	Orange
-	-	19	11	11	SD	Green	Green
White/blue	A+	1	12	12	BAT+	Purple	Purple
White/yellow	A-	2	13	13	BAT+	Gray	Gray
White/red	B+	3	14	14	VCC	Red	Red
White/black	B-	4	15	15	GND	Black	Black
White/purple	Z+	5	16	16	LS-	White/green	White/green
White/gray	Z-	6	17	17	BK-	Blue	Blue
Orange	SRD+	7	18	18	BK+	Yellow	Yellow
Green	SRD-	8	-	-	-	-	-
Purple	BAT+	14	-	-	-	-	-
Gray	BAT-	15	-	-	-	-	-
Red	VCC	16	-	-	-	-	-
Black	GND	17	-	-	-	-	-
Blue	BKR-	20	-	-	-	-	-
Yellow	BKR+	21	-	-	-	-	-
-	-	22	-	-	-	-	-

The shield is connected to the hood by a clamp.

Ground wire and braided shield

(Fig.: EU encoder robot cable CB-XEU3-PA□□□, EU version with metal connector)

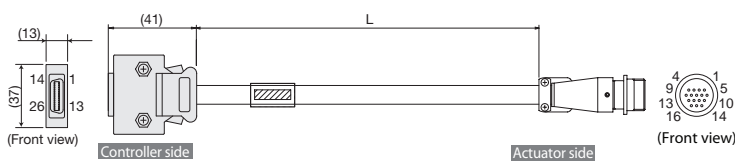

Minimum bending R:  $r = 58$  mm or more (for movable use)

Wire	Color	Signal	No.	No.	Signal	Color	Wire
-	-	-	10	1	SD	Orange	AWG26 soldered
-	-	-	11	2	SD	Green	
-	-	E24V	12	3	A+	White/blue	
-	-	OV	13	4	A-	White/yellow	
White/green	LS	26	4	5	LS+	White/orange	
White/orange	LS	26	5	6	B+	White/red	
-	CREEP	25	6	7	B-	White/black	
-	OT	24	7	8	Z+	White/purple	
-	RSV	23	8	9	Z-	White/gray	
-	-	9	9	10	VCC	Red	
-	-	18	10	11	GND	Black	
-	-	19	11	12	BAT+	Purple	
White/blue	A+	1	12	13	BAT-	Gray	
White/yellow	A-	2	13	14	LS-	White/green	
White/red	B+	3	14	15	BK-	Blue	
White/black	B-	4	15	16	BK+	Yellow	
White/purple	Z+	5	-	-	-	-	
White/gray	Z-	6	-	-	-	-	
Orange	SRD+	7	-	-	-	-	
Green	SRD-	8	-	-	-	-	
Purple	BAT+	14	-	-	-	-	
Gray	BAT-	15	-	-	-	-	
Red	VCC	16	-	-	-	-	
Black	GND	17	-	-	-	-	
Blue	BKR-	20	-	-	-	-	
Yellow	BKR+	21	-	-	-	-	
-	-	22	-	-	-	-	

The shield is clamped to the hood

Ground wire and braided shield

A shield is connected to shield soldered part

## Maintenance Parts

When placing an order for a replacement cable, please use the model name shown below.

<b>Model number</b>	<b>CB-X1-PA</b> □□□□	Encoder robot cable	for RCS4 and models
	<b>CB-XEU1-PA</b> □□□□	EU encoder robot cable	other than NS / RCS2 / RCS3 / DD(A)

\* Enter the cable length (L) into □□□. Compatible to a Maximum of 30 meters.  
Ex.: 080 = 8m

(Fig.: Encoder robot cable CB-X1-PA□□□□ with plastic connector)

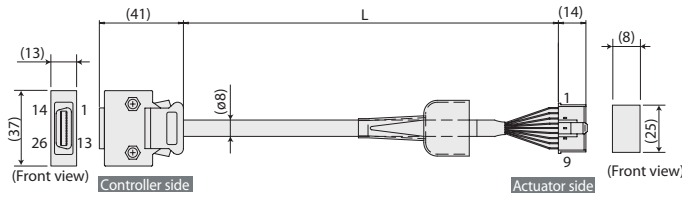

Minimum bend radius R: r = 44mm or larger (for movable use)

\*Only robot cable is available for this model.

\*If you require ISB/ISDB/ISDBCR (encoder type is battery-less absolute) with the cable of 21m or longer, select the CB-X1-PA□□□□-AWG24.

(Fig.: EU encoder robot cable CB-XEU1-PA□□□□, EU version with metal connector)

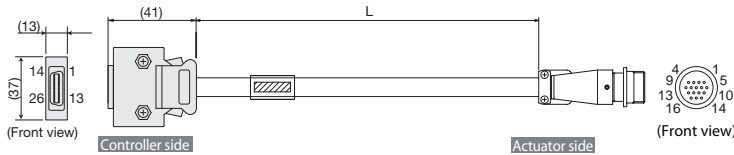

Minimum bend radius R: r = 44mm or larger (for movable use)

\*Only robot cable is available for this model.

\*If you require ISB/ISDB/ISDBCR (encoder type is battery-less absolute) with the cable of 21m or longer, select the CB-XEU1-PA□□□□-AWG24.

Wire	Color	Signal	No.
—	—	—	10
—	—	—	11
—	—	E24V	12
—	—	OV	13
—	—	LS	26
—	—	CREEP	25
—	—	OT	24
—	—	RSV	23
—	—	—	9
—	—	—	18
—	—	—	19
—	—	A+	1
—	—	A-	2
—	—	B+	3
—	—	B-	4
—	—	Z+	5
—	—	Z-	6
Orange	SRD+	7	7
Green	SRD-	8	8
Purple	BAT+	14	14
Gray	BAT-	15	15
Red	VCC	16	16
Black	GND	17	17
Blue	BKR-	20	20
Yellow	BKR+	21	21
—	—	—	22

No.	Signal	Color	Wire
1	BAT+	Purple	AWG26 (crimped)
2	BAT-	Gray	
3	SD	Orange	
4	SD	Green	
5	VCC	Red	
6	GND	Black	
7	FG	Ground	
8	BK-	Blue	
9	BK+	Yellow	

The shield is clamped to the hood

Branded ground & shield wire

Wire	Color	Signal	No.
—	—	—	10
—	—	—	11
—	—	E24V	12
—	—	OV	13
—	—	LS	26
—	—	CREEP	25
—	—	OT	24
—	—	RSV	23
—	—	—	9
—	—	—	18
—	—	—	19
—	—	A+	1
—	—	A-	2
—	—	B+	3
—	—	B-	4
—	—	Z+	5
—	—	Z-	6
Orange	SRD+	7	7
Green	SRD-	8	8
Purple	BAT+	14	14
Gray	BAT-	15	15
Red	VCC	16	16
Black	GND	17	17
Blue	BKR-	20	20
Yellow	BKR+	21	21
—	—	—	22

No.	Signal	Color	Wire
1	SD	Orange	AWG26 soldered
2	SD	Green	
3	—	—	
4	—	—	
5	—	—	
6	—	—	
7	—	—	
8	—	—	
9	—	—	
10	VCC	Red	
11	GND	Black	
12	BAT+	Purple	
13	BAT-	Gray	
14	—	—	
15	BK-	Blue	
16	BK+	Yellow	

The shield is clamped to the hood

Ground wire and braided shield

<b>Model number</b>	<b>CB-X1-PA</b> □□□□-AWG24	Encoder low-resistance robot cable	for models with battery-less absolute
	<b>CB-XEU1-PA</b> □□□□-AWG24	EU encoder low-resistance robot cable	encoder other than NS / RCS2 / RCS3

\* Enter the cable length (L) into □□□. Compatible to a Maximum of 30 meters.  
Ex.: 210 = 21m

(Fig.: Encoder robot cable CB-X1-PA□□□□-AWG24 with plastic connector)

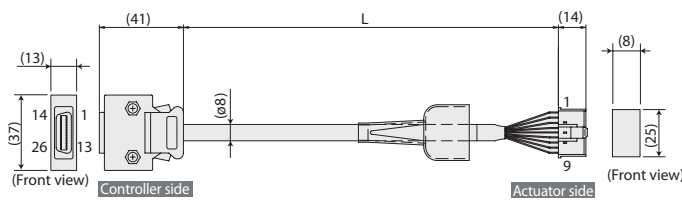

Minimum bend radius R: r = 44mm or larger (for movable use)

\*Only robot cable is available for this model.

(Fig.: EU encoder robot cable CB-XEU1-PA□□□□-AWG24, EU version with metal connector)

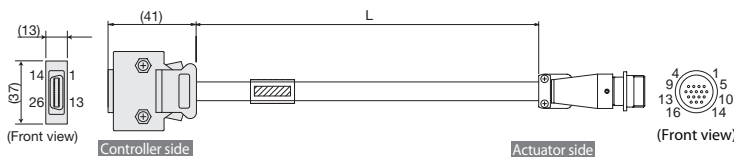

Minimum bend radius R: r = 44mm or larger (for movable use)

\*Only robot cable is available for this model.

Wire	Color	Signal	No.
—	—	—	10
—	—	—	11
—	—	E24V	12
—	—	OV	13
—	—	LS	26
—	—	CREEP	25
—	—	OT	24
—	—	RSV	23
—	—	—	9
—	—	—	18
—	—	—	19
—	—	A+	1
—	—	A-	2
—	—	B+	3
—	—	B-	4
—	—	Z+	5
—	—	Z-	6
Orange	SRD+	7	7
Green	SRD-	8	8
—	BAT+	14	14
—	BAT-	15	15
Red	VCC	16	16
Black	GND	17	17
Blue	BKR-	20	20
Yellow	BKR+	21	21
—	—	—	22

No.	Signal	Color	Wire
1	BAT+	—	AWG24 (crimped)
2	BAT-	—	
3	SD	Orange	
4	SD	Green	
5	VCC	Red	
6	GND	Black	
7	FG	Ground	
8	BK-	Blue	
9	BK+	Yellow	

The shield is clamped to the hood

Twisted pair

Ground wire and braided shield

Wire	Color	Signal	No.
—	—	—	10
—	—	—	11
—	—	E24V	12
—	—	OV	13
—	—	LS	26
—	—	CREEP	25
—	—	OT	24
—	—	RSV	23
—	—	—	9
—	—	—	18
—	—	—	19
—	—	A+	1
—	—	A-	2
—	—	B+	3
—	—	B-	4
—	—	Z+	5
—	—	Z-	6
Orange	SRD+	7	7
Green	SRD-	8	8
—	BAT+	14	14
—	BAT-	15	15
Red	VCC	16	16
Black	GND	17	17
Blue	BKR-	20	20
Yellow	BKR+	21	21
—	—	—	22

No.	Signal	Color	Wire
1	SD	Orange	AWG24 soldered
2	SD	Green	
3	—	—	
4	—	—	
5	—	—	
6	—	—	
7	—	—	
8	—	—	
9	—	—	
10	VCC	Red	
11	GND	Black	
12	BAT+	—	
13	BAT-	—	
14	—	—	
15	BK-	Blue	
16	BK+	Yellow	

The shield is clamped to the hood

Twisted pair

Ground wire and braided shield

Model number	<b>CB-X1-PLA</b> <input type="checkbox"/> <input type="checkbox"/> <input type="checkbox"/>	Limit switch encoder robot cable	for LS specification models other than NS / RCS2 / RCS3
	<b>CB-XEU1-PLA</b> <input type="checkbox"/> <input type="checkbox"/> <input type="checkbox"/>	EU limit switch encoder robot cable	

\* Enter the cable length (L) into . Compatible to a Maximum of 30 meters.  
Ex.: 080 = 8m

(Fig.: LS encoder robot cable CB-X1-PLA  with plastic connector)

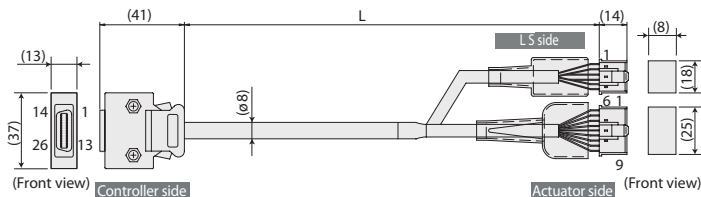

Minimum bend. radius R: r = 54mm or larger (for movable use)

\*Only robot cable is available for this model.

\*If you require ISB/ISDB/ISDBCR (encoder type is battery-less absolute) with the cable of 21m or longer, select the CB-X1-PLA -AWG24.

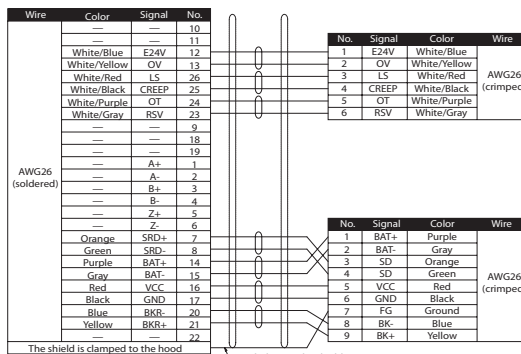

(Fig.: EU LS encoder robot cable CB-XEU1-PLA , EU version with metal connector)

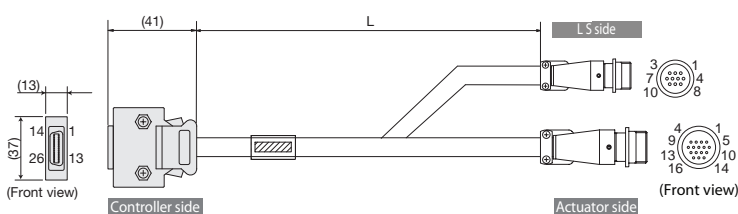

Minimum bend. radius R: r = 54mm or larger (for movable use)

\*Only robot cable is available for this model.

\*If you require ISB/ISDB/ISDBCR (encoder type is battery-less absolute) with the cable of 21m or longer, select the CB-XEU1-PLA -AWG24.

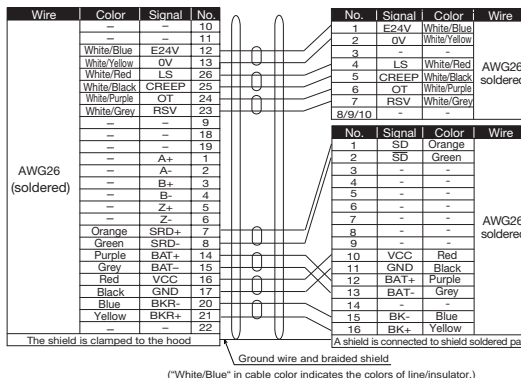

Model number	<b>CB-RCS2-PLA</b> <input type="checkbox"/> <input type="checkbox"/> <input type="checkbox"/>	Limit switch encoder cable	for RCS2 Rotary type for LS specification models NS / RCS2 Rotary type
	<b>CB-X2-PLA</b> <input type="checkbox"/> <input type="checkbox"/> <input type="checkbox"/>	Limit switch encoder robot cable	
	<b>CB-XEU2-PLA</b> <input type="checkbox"/> <input type="checkbox"/> <input type="checkbox"/>	EU limit switch encoder robot cable	

\* Enter the cable length (L) into . Compatible to a Maximum of 30 meters.  
Ex.: 080 = 8m

(Fig.: LS encoder cable CB-RCS2-PLA  / CB-X2-PLA  with plastic connector)

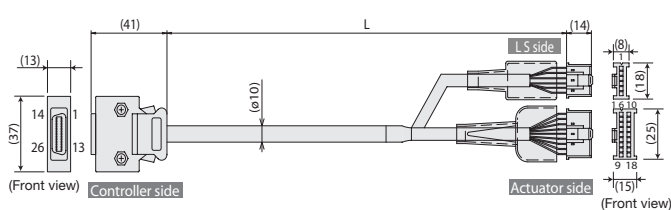

Minimum bending R: r = 58 mm or more (for movable use)

\* If the cable must be guided in a cable track, use a robot cable.

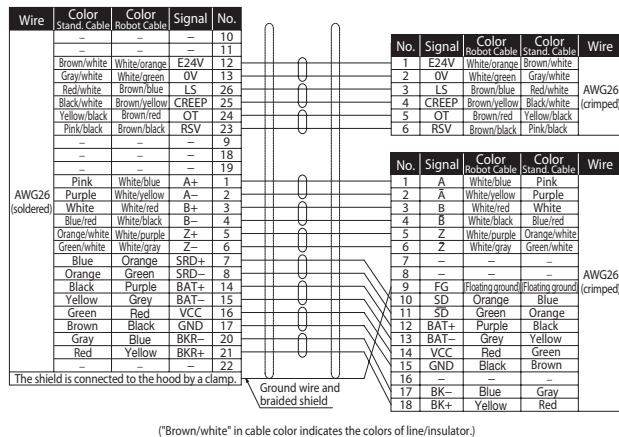

(\*Brown/white" in cable color indicates the colors of line/insulator.)

(Fig.: EU LS encoder robot cable CB-XEU2-PLA , EU version with metal connector)

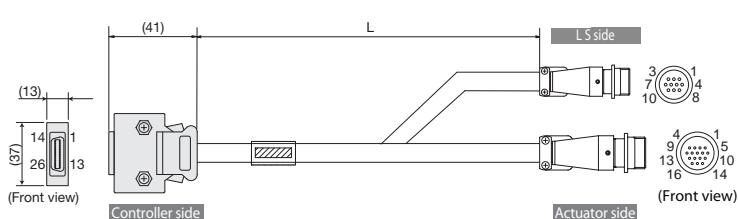

Minimum bending R: r = 58 mm or more (for movable use)

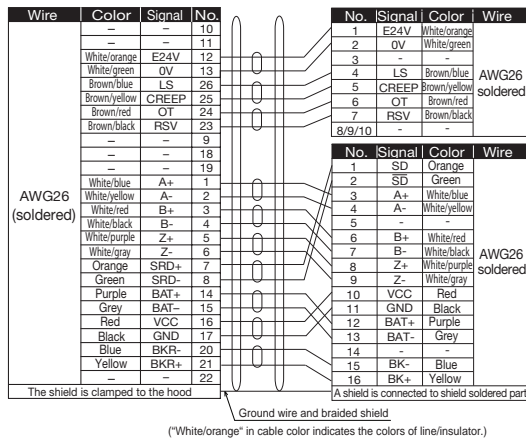

(\*White/orange" in cable color indicates the colors of line/insulator.)

## Maintenance Parts

When placing an order for a replacement cable, please use the model name shown below.

<b>Model number</b>	<b>CB-X1-PLA</b> <input type="checkbox"/> <input type="checkbox"/> <input type="checkbox"/> <input type="checkbox"/> <b>-AWG24</b>	Limit switch encoder low-resistance robot cable
	<b>CB-XEU1-PLA</b> <input type="checkbox"/> <input type="checkbox"/> <input type="checkbox"/> <input type="checkbox"/> <b>-AWG24</b>	EU limit switch encoder low-resistance robot cable

for LS specification models with battery-less absolute encoder other than NS / RCS2 / RCS3

\* Enter the cable length (L) into . Compatible to a Maximum of 30 meters.  
Ex.: 210 = 21m

(Fig.: LS encoder low-resistance robot cable CB-X1-PLA -AWG24 with plastic connector)

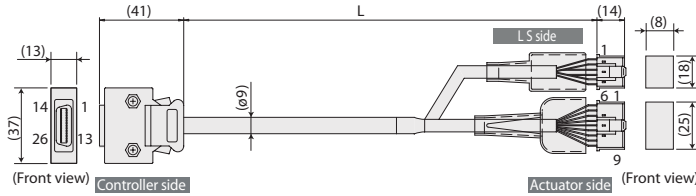

Minimum bend. radius R: r = 54mm or larger (for movable use)

\*Only robot cable is available for this model.

(Fig.: EU LS encoder low-resistance robot cable CB-XEU1-PLA -AWG24, EU version with metal connector)

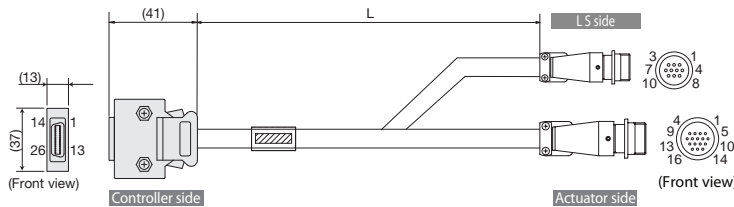

Minimum bend. radius R: r = 54mm or larger (for movable use)

\*Only robot cable is available for this model.

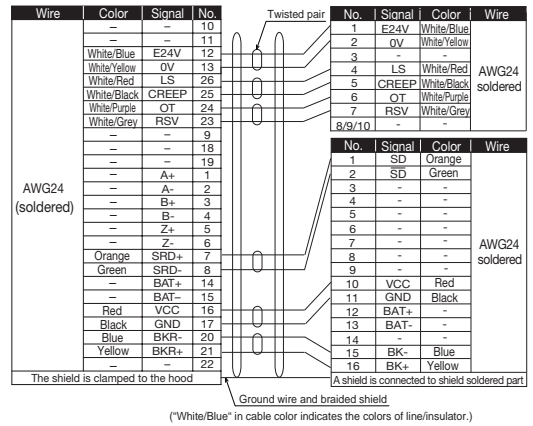
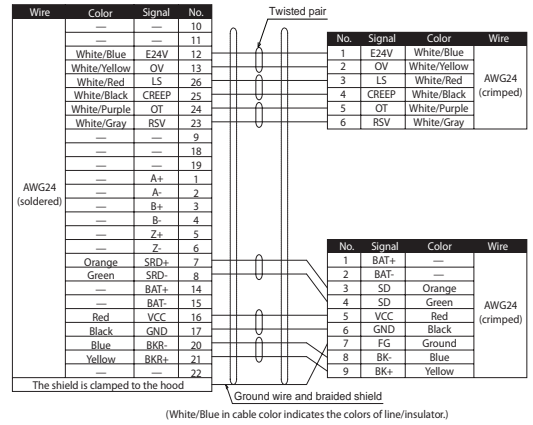

<b>Model number</b>	<b>CB-X1-PA</b> <input type="checkbox"/> <input type="checkbox"/> <input type="checkbox"/> <input type="checkbox"/> <b>-WC</b>	Encoder robot cable
---------------------	--	---------------------

(Dedicated motor robot cable: CB-XEU-MA  , see P. 162)

for splash-proof slider ISWA

\* Enter the cable length (L) into . Compatible to a Maximum of 30 meters.  
Ex.: 080 = 8m

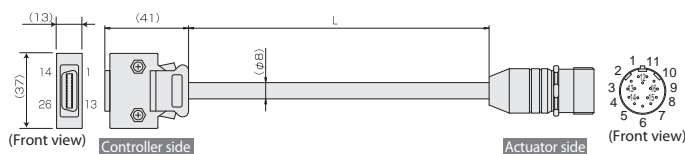

Minimum bend. radius R: r = 38mm or larger (for movable use)

\*Only robot cable is available for this model.

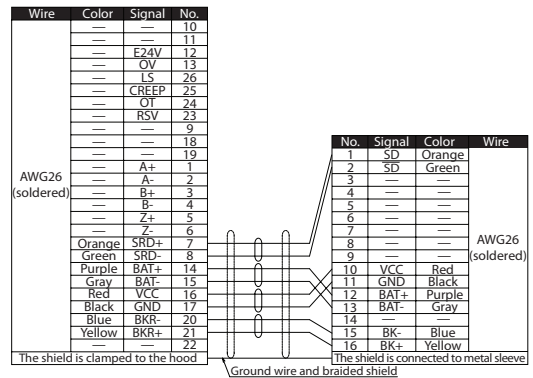

**Model number** **CB-PAC-PIO** □□□ I/O Flat Cable for SCON-CB

\*Please indicate the cable length (L) in □□□ (e.g. 080=8m). Maximum length = 10m

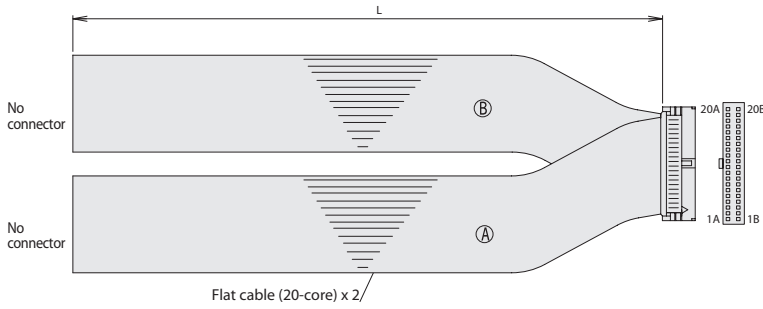

HIF6-40D-1.27R

No.	Signal	Color	Wire	No.	Signal	Color	Wire
1A	24V	Brown-1	Flat cable® (crimped)	18	OUT0	Brown-3	Flat cable® (crimped) AWG28
2A	24V	Red-1		28	OUT1	Red-3	
3A	-	Orange-1		38	OUT2	Orange-3	
4A	-	Yellow-1		48	OUT3	Yellow-3	
5A	IN0	Green-1		58	OUT4	Green-3	
6A	IN1	Blue-1		68	OUT5	Blue-3	
7A	IN2	Purple-1		78	OUT6	Purple-3	
8A	IN3	Gray-1		88	OUT7	Gray-3	
9A	IN4	White-1		98	OUT8	White-3	
10A	IN5	Black-1		108	OUT9	Black-3	
11A	IN6	Brown-2		118	OUT10	Brown-4	
12A	IN7	Red-2		128	OUT11	Red-4	
13A	IN8	Orange-2		138	OUT12	Orange-4	
14A	IN9	Yellow-2		148	OUT13	Yellow-4	
15A	IN10	Green-2		158	OUT14	Green-4	
16A	IN11	Blue-2		168	OUT15	Blue-4	
17A	IN12	Purple-2		178	-	Purple-4	
18A	IN13	Gray-2		188	-	Gray-4	
19A	IN14	White-2		198	0V	White-4	
20A	IN15	Black-2		208	0V	Black-4	

**Model number** **CB-SC-PIOS** □□□ SCON Pulse-train Control Cable for SCON-CB

\*Please indicate the cable length (L) in □□□ (e.g. 080=8m). Maximum length = 10m

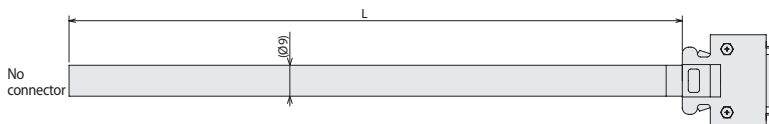

Wire	Color	Signal	No.
Black	Black	Not used	1
White/Black	White/Black	Not used	2
Red	Red	PP	3
White/Red	White/Red	/PP	4
Green	Green	NP	5
White/Green	White/Green	/NP	6
Yellow	Yellow	AFB	7
White/Yellow	White/Yellow	/AFB	8
Brown	Brown	BFB	9
White/Brown	White/Brown	/BFB	10
Blue	Blue	ZFB	11
White/Blue	White/Blue	/ZFB	12
Gray	Gray	GND	13
White/Gray	White/Gray	GND	14
Shield	Shield	The shield is connected to cable clamp	

**Model number** **CB-DDB-BK** □□□ Brake Cable for DDA / DDACR

\*Please indicate the cable length (L) in □□□ (e.g. 080=8m). Maximum length = 20m

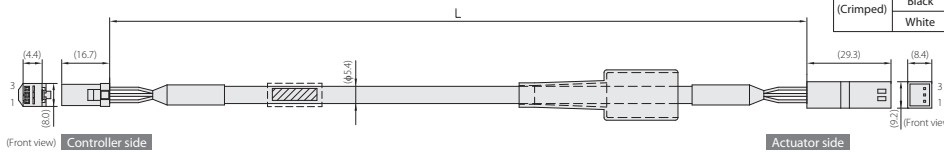

J115F-03V-KX				J115FM-03V-KX			
Wiring	Color	Signal	No.	No.	Signal	Color	Wiring
AWG20 (Crimped)	Red	+	3	3	+	Red	AWG20 (Crimped)
	Black	-	2	2	-	Black	
	White	FG	1	1	FG	White	

**RCS4/RCS4CR Series  
Slider / Rod / Table Type  
Catalogue No. 0918-E**

The information contained in this catalog  
is subject to change without notice for the  
purpose of product improvement



**IAI Industrieroboter GmbH**  
Ober der Röth 4  
D-65824 Schwalbach / Frankfurt  
Germany  
Tel.: +49-6196-8895-0  
Fax: +49-6196-8895-24  
E-Mail: [info@IAI-GmbH.de](mailto:info@IAI-GmbH.de)  
Internet: <http://www.IAI-GmbH.eu>

---

**IAI America, Inc.**

2690 W. 237th Street, Torrance, CA 90505, U.S.A  
Phone: +1-310-891-6015, Fax: +1-310-891-0815

**IAI (Shanghai) Co., Ltd**

Shanghai Jiahua Business Center A8-303, 808,  
Hongqiao Rd., Shanghai 200030, China  
Phone: +86-21-6448-4753, Fax: +86-21-6448-3992

**IAI CORPORATION**

577-1 Obane, Shimizu-Ku, Shizuoka, 424-0103 Japan  
Phone: +81-543-64-5105, Fax: +81-543-64-5192

**IAI Robot (Thailand) Co., Ltd**

825 PhairojKijja Tower 12th Floor, Bangna-Trad RD.,  
Bangna, Bangna, Bangkok 10260, Thailand  
Phone: +66-2-361-4457, Fax: +66-2-361-4456