

**ROBO Cylinder
with Battery-less Absolute Encoder**

Cleanroom Type

RCP5 RCP5CR



**Battery-less
Absolute**

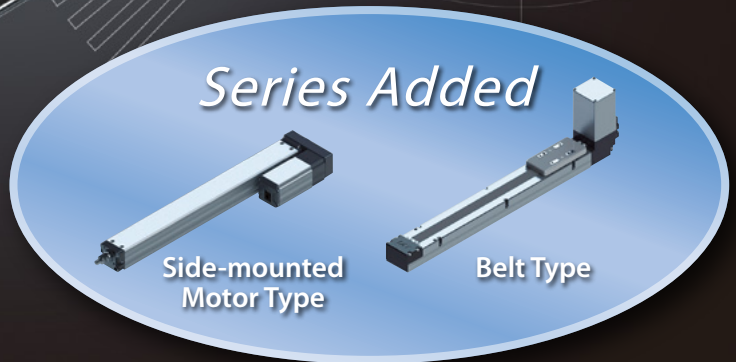

Introducing the RCP5 Series, powered by a battery-less actuator, with the convenience of an absolute encoder and the cost and simplicity of an incremental encoder

The innovative battery-less absolute encoder (patent pending), operates through the combination of gears recognizing the rotational position data, which eliminates the need for a battery that is normally required for a conventional absolute encoder. This means there is no longer a need for battery replacement, as well as the associated costs and adjustments.

Slider Type

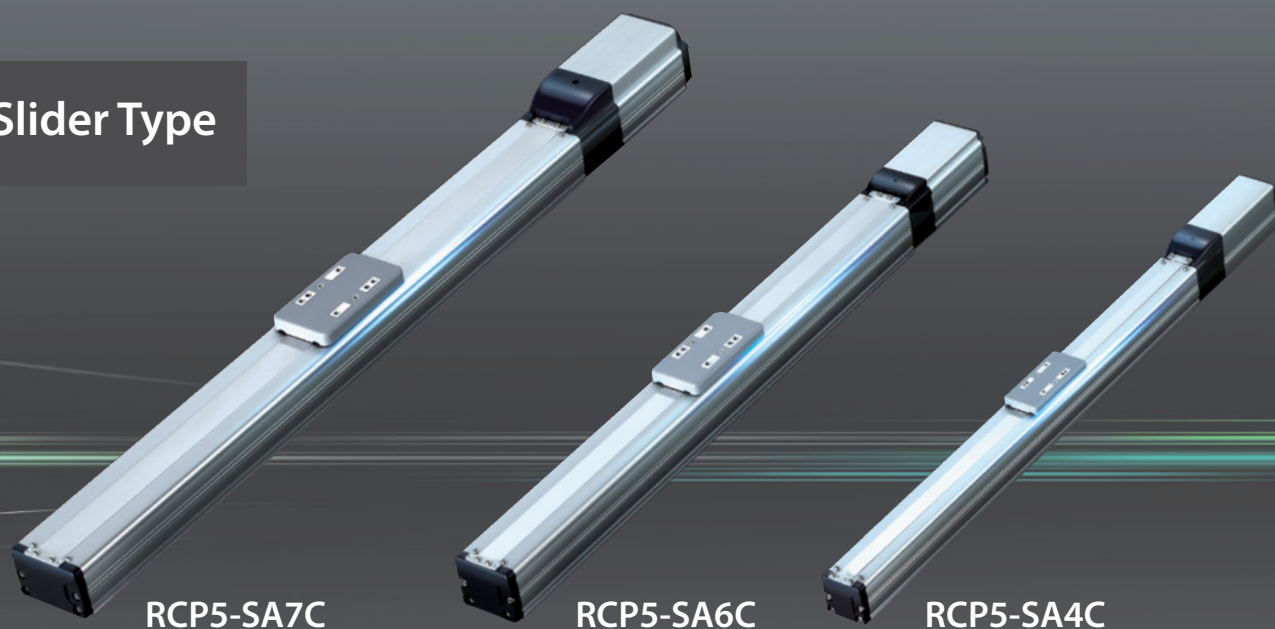

RCP5-SA7C

RCP5-SA6C

RCP5-SA4C

Rod Type

Radial Cylinder
Can carry radial loads

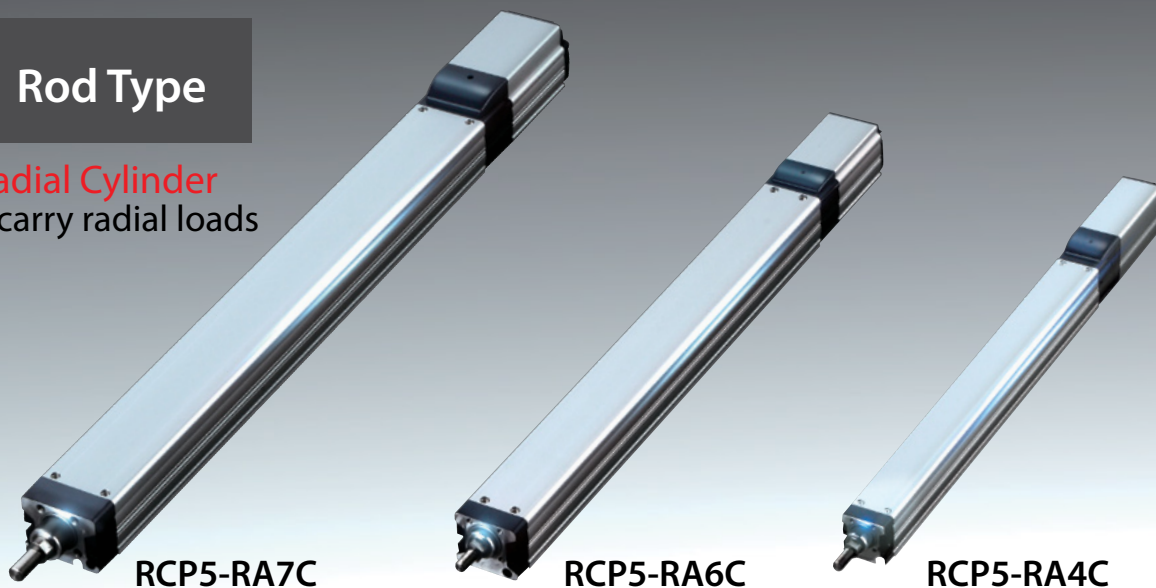

RCP5-RA7C

RCP5-RA6C

RCP5-RA4C

Added to the Series: Side-mounted Motor and Belt Types

Compared to the existing model (RCP2-BA), the belt type is;

- Compatible to a maximum long stroke of 2,600mm
- Equipped with a standard stainless steel sheet
- 1.5 times higher in maximum speed and maximum payload

Side-mounted Motor Type

Slider Type



RCP5-SA4R
-SA6R
-SA7R

Rod Type
(Radial Cylinder)



RCP5-RA4R
-RA6R
-RA7R

Belt Type

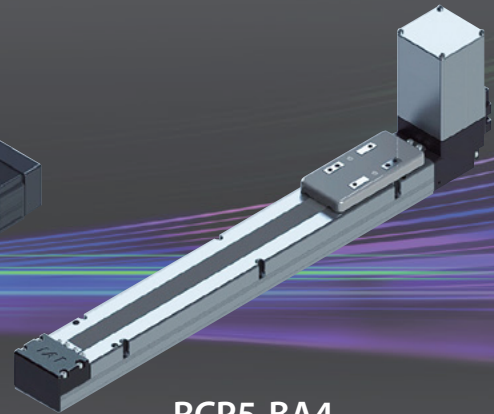

RCP5-BA4
-BA6
-BA7

Cleanroom Type

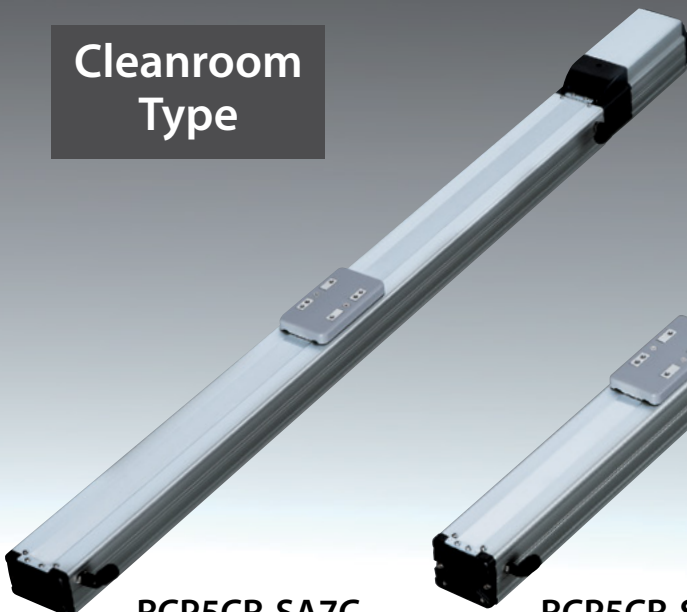

RCP5CR-SA7C



RCP5CR-SA6C



RCP5CR-SA4C

Variations : RCP5 Series

Values in () are for vertical use.

Slider Type

Model	Type	Actuator Width	Stroke (mm)	Ballscrew Lead (mm)	Max. Speed (mm/s)	Max. Payload (kg)	
						Horizontal	Vertical
Straight Motor	SA4C	40mm	50~500	16/10/5/2.5	1260/785/390/195	4/10/12/12	1/2.25/4.5/9
	SA6C	58mm	50~800	20/12/6/3	1440(1280)/900/450/225	10/15/25/25	1/2.5/6/16
	SA7C	73mm	50~800	24/16/8/4	1200/980(840)/490/245(210)	20/40/45/45	3/8/16/25
Side-Mounted Motor	NEW SA4R	40mm	50~500	16/10/5/2.5	1260/785/390/195	4/10/12/12	1/2.25/4.5/9
	NEW SA6R	58mm	50~800	20/12/6/3	1280/900(800)/450/225	10/15/25/25	1/2.5/6/12
	NEW SA7R	73mm	50~800	24/16/8/4	1000/840(700)/490/210	20/40/45/45	3/8/16/25

Rod Type

Model	Type	Actuator Width	Stroke (mm)	Ballscrew Lead (mm)	Max. Speed (mm/s)	Max. Payload (kg)	
						Horizontal	Vertical
Straight Motor	RA4C	40mm	60~410	16/10/5/2.5	1120(840)/700/350/175	6/15/28/40	1.5/2.5/5/10
	RA6C	58mm	65~415	20/12/6/3	800/700/450/225	6/25/40/60	1.5/4/10/20
	RA7C	73mm	70~520	24/16/8/4	800(700)/700(560)/420/210	20/50/60/80	3/8/18/28
	RA8C	88mm	50~700	20/10/5	600(450)/300(250)/150	30/60/100	5/40/70
	RA10C	108mm	50~800	10/5/2.5	250(167)/125/63	80/150/300	80/100/150
Side-Mounted Motor	NEW RA4R	40mm	60~410	16/10/5/2.5	840/610/350/175	5/12/25/40	1/2.5/5/10
	NEW RA6R	58mm	65~415	20/12/6/3	800/700/450/225	6/25/40/60	1.5/4/10/20
	NEW RA7R	73mm	70~520	24/16/8/4	800(600)/560/420(350)/175	20/50/60/80	3/8/18/28
	RA8R	88mm	50~700	20/10/5	400/200/100	30/60/100	5/40/70
	RA10R	108mm	50~800	10/5/2.5	200(140)/100/50	80/150/300	80/100/150

Cleanroom Type

Type	Actuator Width	Stroke (mm)	Ballscrew Lead (mm)	Max. Speed (mm/s)	Max. Payload (kg)	
					Horizontal	Vertical
SA4C	40mm	50~500	16/10/5/2.5	1260/785/390/195	4/10/12/12	1/2.25/4.5/9
SA6C	58mm	50~800	20/12/6/3	1440(1280)/900/450/225	10/15/25/25	1/2.5/6/16
SA7C	73mm	50~800	24/16/8/4	1200/980(840)/490/245(210)	20/40/45/45	3/8/16/25

Belt Type

Type	Actuator Width	Stroke (mm)	Ballscrew Lead (mm)	Max. Speed (mm/s)	Max. Payload (kg)	
					Horizontal	
NEW BA4/BA4U	40mm	300~1200	Equivalent to 48	1200	1.5	
NEW BA6/BA6U	58mm	300~2200	Equivalent to 48	1500	6	
NEW BA7/BA7U	70mm	300~2600	Equivalent to 48	1600	16	

IAI America, Inc.

Headquarters: 2690 W. 237th Street, Torrance, CA 90505 (800) 736-1712
Chicago Office: 110 E. State Parkway, Schaumburg, IL 60173 (800) 944-0333
Atlanta Office: 1220 Kennestone Circle, Suite 108, Marietta, GA 30066 (888) 354-9470

www.intelligentactuator.com

The information contained in this product brochure may change without prior notice due to product improvements.

IAI Industrieroboter GmbH

Ober der Röth 4, D-65824 Schwalbach am Taunus, Germany

IAI Robot (Thailand), CO., Ltd.

825 PhairojKijja Tower 12th Floor, Bangna-Trad RD.,
Bangna, Bangna, Bangkok 10260, Thailand